

GEORGE FOREMAN®

KETTLE BBQ - GFKTBBQ

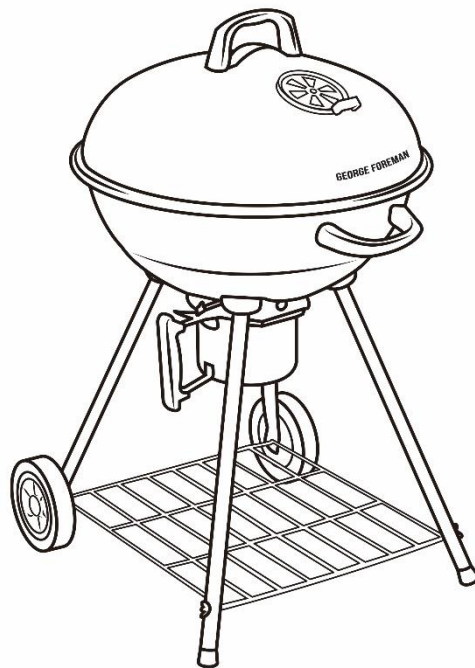

WARNING: CARBON MONOXIDE HAZARD

Burning charcoal inside can kill you. It gives off carbon monoxide which has no odour. NEVER burn charcoal in enclosed spaces e.g. homes, vehicles or tents

PLEASE RETAIN INSTRUCTIONS FOR FUTURE REFERENCE

For Customer Services & Spare Parts please call **0345 209 7461**
Opening times: Monday - Friday 8am – 8pm & Saturday 9am – 1pm
Or visit us at **www.productcare.co.uk**

CONTENTS

| | Page(s) |
|---------------------------------|----------------|
| Safety instructions | 3 |
| BBQ Feature Diagram | 4 |
| BBQ Parts List | 5-6 |
| BBQ Assembly | 7-10 |
| Lighting your BBQ | 11 |
| Food Safety | 12 |
| Cleaning and care | 13 |
| Guarantee and customer services | 14 |
| Notes | 15 |

SAFETY INSTRUCTIONS

IMPORTANT SAFETY INSTRUCTIONS READ CAREFULLY AND KEEP FOR FUTURE REFERENCE

WARNING:

- The Barbeque must be installed on a secure level base prior to use.
- The Barbeque shall be heated up for at least 30 minutes prior to the first cooking on the barbeque.
- Ensure that the coals placed do not exceed half the height between the cooking grill and the coal area.
- **WARNING! This barbecue will become very hot, do not move it during operation.**
- **Do not use indoors!**
- **WARNING! Do not use spirit or petrol for lighting or re-lighting! Use only firelighters complying to EN 1860-3!**
- **WARNING! Keep children and pets away.**

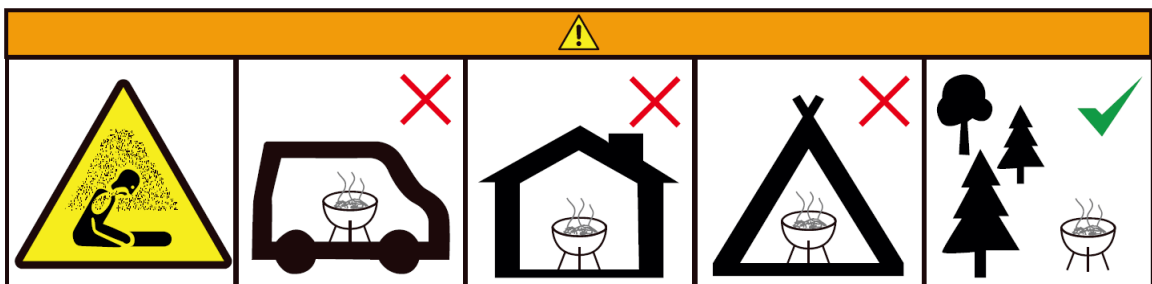

Carbon Monoxide Do not use in Do Not Use Do Not Use in Use in open
Poisoning Hazard Motor Homes Indoors Tents Spaces

WARNING! Do not use the barbecue in a confined and/or habitable space e.g. houses, tents, caravans, motor homes, boats. Danger of carbon monoxide poisoning fatality.

BBQ FEATURE DIAGRAM

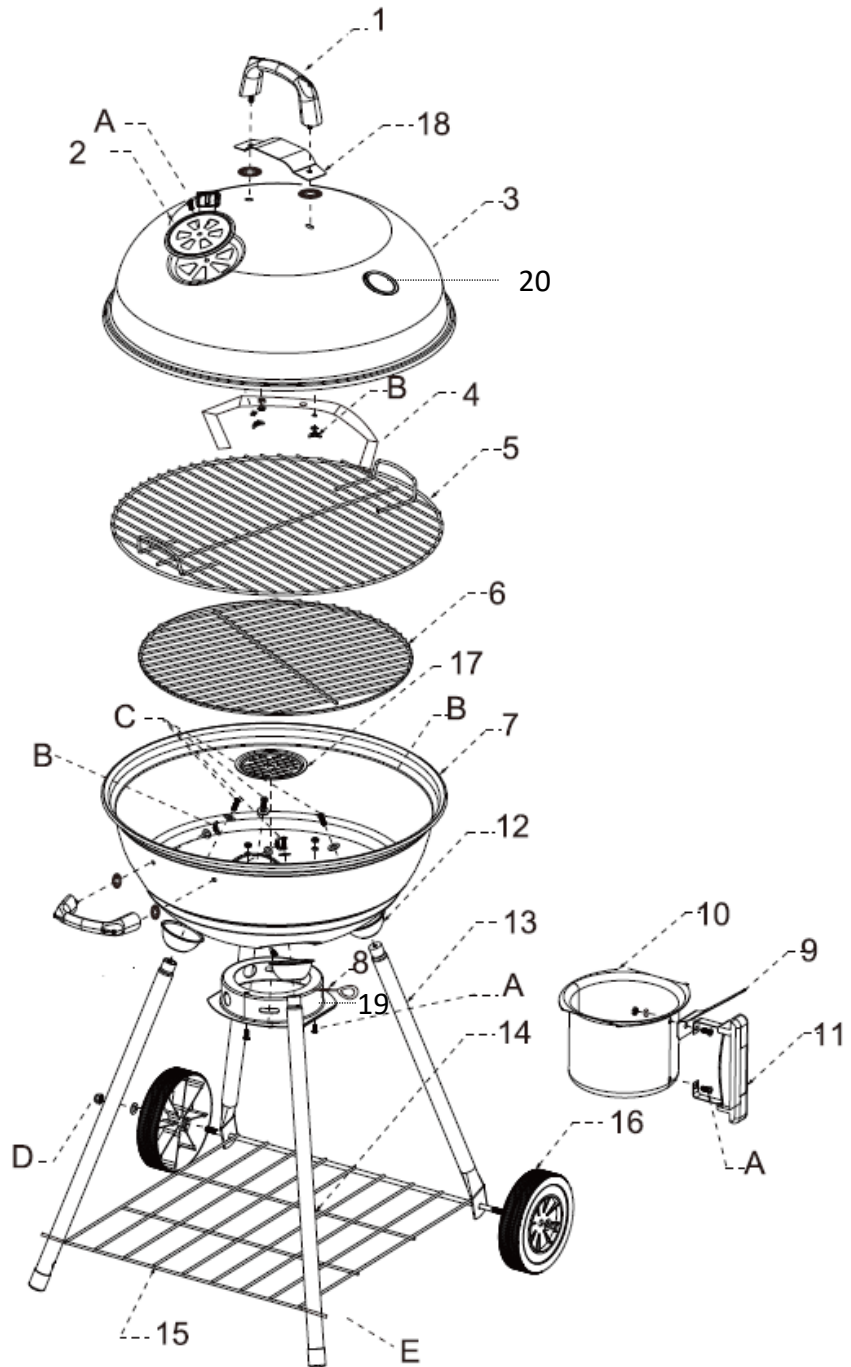

You will need...

- Cross Head Screwdriver
- Adjustable Spanner

BBQ PARTS LIST

| PART | DESCRIPTION | QTY |
|------|--|-----|
| 1 | Lid and Fire Bowl Handle | 2 |
| 2 | Lid air vent | 1 |
| 3 | Lid | 1 |
| 4 | Lid support | 1 |
| 5 | Cooking grill | 1 |
| 6 | Charcoal grill | 1 |
| 7 | Fire bowl | 1 |
| 8 | Fire bowl air vent and adjustment lever (preassembled) | 1 |
| 9 | Heat deflector | 1 |
| 10 | Ash cup | 1 |
| 11 | Ash cup handle | 1 |
| 12 | Leg cups | 4 |
| 13 | Wheel leg | 2 |
| 14 | Long leg | 2 |
| 15 | Shelf | 1 |
| 16 | Wheel | 2 |
| 17 | Ash grill | 1 |
| 18 | Heat resistant plate | 1 |
| 19 | Ash cup ring (preassembled) | 1 |
| 20 | Thermostat | 1 |

BBQ PARTS LIST

| PART | DESCRIPTION | SIZE | QTY |
|------|----------------|-----------|-----|
| A | Bolt | M5 x 10 | 5 |
| | Washer | Ø6 x 12mm | 5 |
| | Nut | M5 | 5 |
| B | Washer (Fibre) | Ø6 x 18mm | 4 |
| | Washer | Ø6 x 16mm | 4 |
| | Wing Nut | M6 | 4 |
| C | Bolt* | M6 x 30 | 4 |
| | Washer* | Ø6 x 20mm | 4 |
| D | Wheel Nut | M8 | 2 |
| E | Wing Nut | M6 | 2 |

*Parts C are preassembled on the leg (13) (14)

BBQ ASSEMBLY

Assembling the Lid

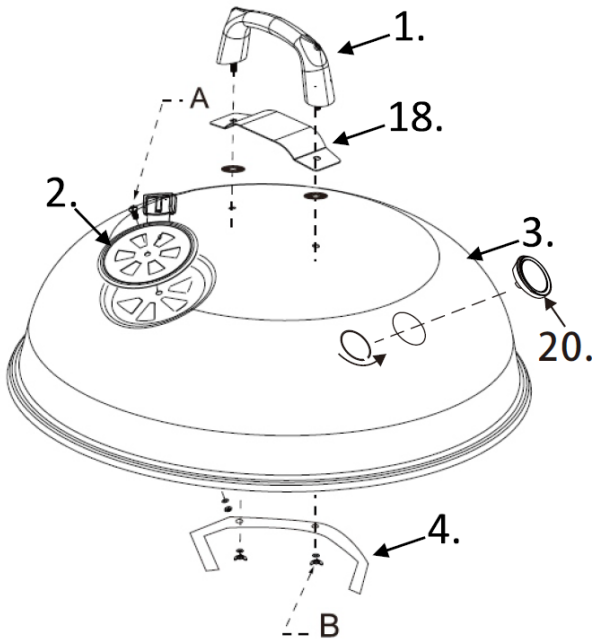

1. Attach one of the **handles** (1), the **heat resistant plate** (18) and the **lid support** (4) onto the **lid** (3) using 2 each of the “B” Washers and Wing Nuts.

The lid support should be placed on the inside of the lid.

Ensure the fibre washers are placed on the outside of the lid and the metal washers and wing nuts are placed on the inside of the lid.

2. Attach the thermostat (20) onto the lid (3)
3. Attach the **lid air vent** (2) onto the **lid** (3) using 1 each of the “A” Bolts, Washers and Nuts.

Ensure the bolt is placed on the outside of the fire bowl and the washer and nut are placed on the inside of the fire bowl.

Assembling the Fire Bowl

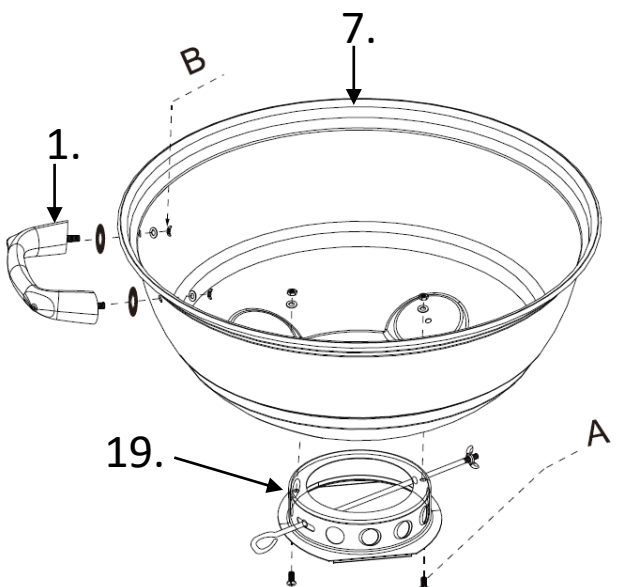

1. Attach one of the **handles** (1) onto the **fire bowl** (7) using 2 each of the “B” Washers and Wing Nuts.
Ensure the fibre washers are placed on the outside of the fire bowl and the metal washers and wing nuts are placed on the inside of the fire bowl.

2. Attach the **ash cup ring** (19) to the bottom of the fire bowl using 2 each of the “A” Bolts, Washers and Nuts.
Ensure the bolts are placed on the outside of the fire bowl and the washers and nuts are placed on the inside of the fire bowl.

BBQ ASSEMBLY

Assembling the Legs

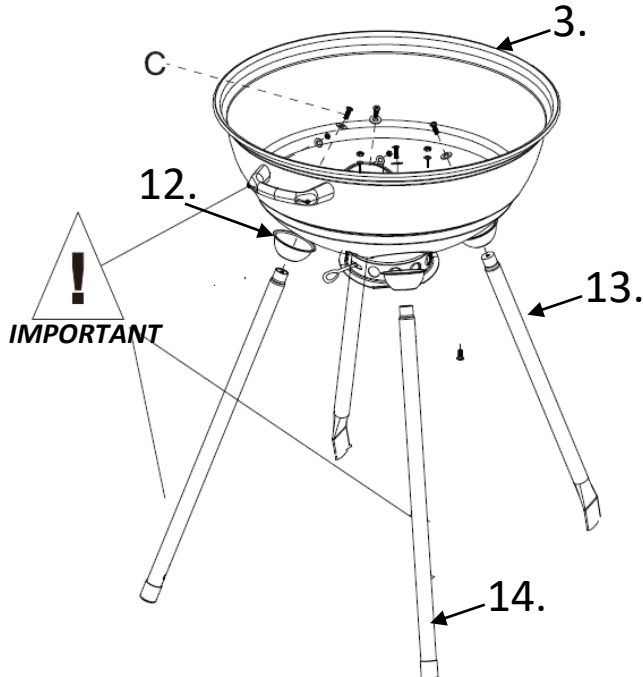

1. Remove the “C” Bolts and Washers that have been preassembled onto the legs (13 & 14).
2. Attach the **leg cups** (12), **long legs** (14) and **wheel legs** (13) to the **body** (3) using the “C” Bolts and Washers.

IMPORTANT: Ensure the **long legs** (14) are attached to the handle side of the body.

Adding the Shelf

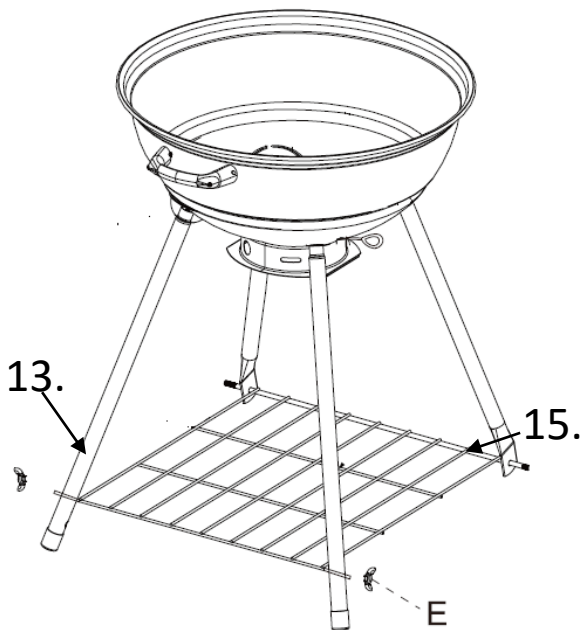

1. Attach the **shelf** (15) to the legs. Use the 2 “E” wing nuts to secure the shelf to the **long legs** (13).

BBQ ASSEMBLY

Attaching the Wheels

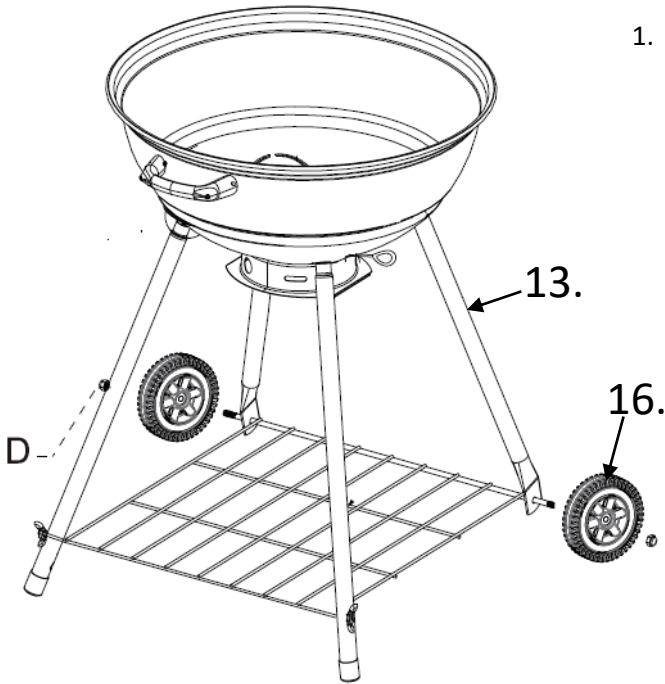

1. Attach the **wheels** (16) onto the shelf struts protruding through the wheel legs (13) using 2 of the “D” wing nuts.

Assembling the Ash Cup

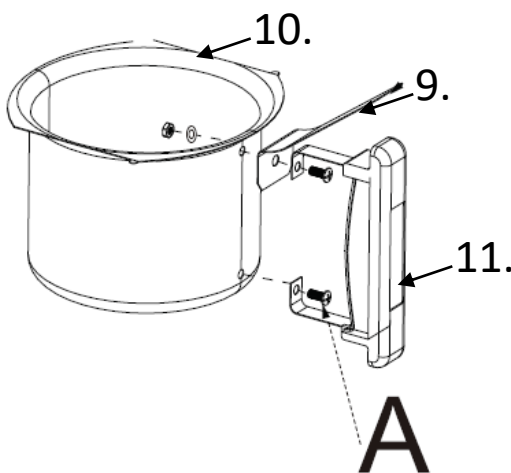

1. Attach the **heat deflector** (9) and the **ash cup handle** (11) to the **ash cup** (10) using 1 each of the “A” Bolts, Washers and Nuts.

Ensure the bolt is placed on the outside of the ash cup and the washer and nut are placed on the inside of the ash cup.

BBQ ASSEMBLY

Assembling your BBQ

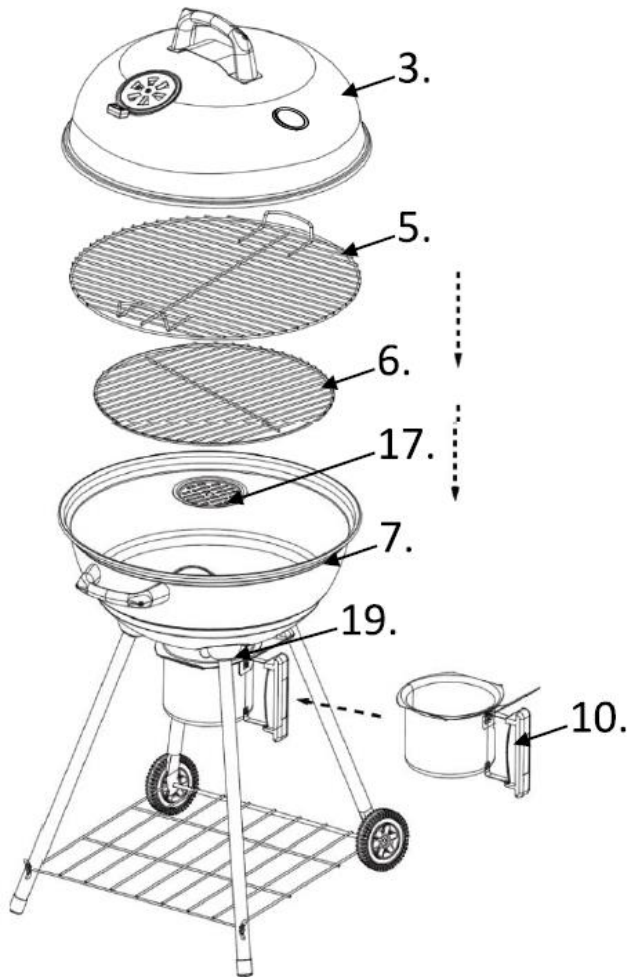

1. Place the **ash grill** (17) into the base of the **fire bowl** (7) followed by the **charcoal grill** (6) and finally the **cooking grill** (5) Slide the **ash cup assembly** (10) into the **ash cup ring** (19)
2. Slide the **ash cup assembly** (10) into the **ash cup ring** (19)
3. Place the **lid assembly** (3) onto the **fire bowl** (7).

Your BBQ is now assembled.

The lid can be suspended from the rim of the fire bowl using the lid support to act as a windshield.

LIGHTING YOUR BBQ

**WARNING! Do not use spirit or petrol for lighting or re-lighting!
Use only firelighters complying to EN 1860-3!**

1. Remove the cooking grill and place a small quantity charcoal into the charcoal pan and light in accordance with the instructions on the charcoal pack.
2. Close the lid and open the air vent to obtain satisfactory combustion. Opening the air vents will increase the airflow and cause the charcoal to burn more fiercely. Wear oven gloves when adjusting the air vent.
3. When the charcoal becomes red hot add more charcoal for cooking. Maximum fill level for charcoal is 1 kg.
4. Replace the cooking grill and wait approximately 20-30 minutes before cooking and do not cook before the fuel has a coating of ash.

CAUTION

When using barbecue for the first time allow the charcoal to remain red hot for at least 30 minutes before cooking.

Accessible parts will be hot - wear oven gloves when touching the barbecue and adjusting the air vent.

Do not extinguish with water as this may damage the barbecue.

FOOD SAFETY

Thoroughly defrost frozen meat and poultry in the refrigerator before cooking. Keep raw meat and poultry separate from cooked foods.

Always wash hands after handling raw meat and poultry, before handling any ready to eat foods.

Wipe and disinfect surfaces that have been in contact with raw meat and poultry.

When barbecuing meat and poultry, make sure the barbecue is really hot. Place the larger, thicker portions furthest away from the most intense heat to ensure thorough cooking without burning and turn regularly.

Use separate utensils for handling raw meat/poultry and cooked food on the barbecue, or wash them thoroughly between uses.

To check whether meat, particularly poultry, is cooked, pierce the flesh with a skewer or fork; the juices should run clear. Ensure the product is piping hot throughout.

CLEANING AND CARE

Removing the Ash

Allow the barbecue and ash to become completely cold before emptying.

Remove the ash cup and safely dispose of the cold ash in a fire proof container or dampen with water to ensure the ash is entirely cold before disposing in a suitable container.

Remove the cooking grill before inverting the barbecue and emptying the ash into a suitable container.

Care and Maintenance

Empty the ash from the barbecue and clean after each use.

The fire bowl, cooking grill and charcoal pan can be cleaned using barbecue cleaning fluid. Avoid using wire wool and brushes as these may scratch the surface.

When not in use this barbecue should be stored in a dry location or under a waterproof cover.

GUARANTEE AND **CUSTOMER SERVICES**

This product is guaranteed for **12 months** from the date of the original purchase. If any defect arises due to faulty materials or workmanship, the faulty product must be returned to the place of purchase.

Refund or replacement is at the discretion of the retailer.

The following conditions apply:

- The product must be returned to the retailer with the original proof of purchase.
- The product must be installed and used in accordance with the instructions contained in this instruction guide and any other instructions for use which are supplied.
- It must be used for domestic purposes only and for its intended use.
- This warranty does not cover wear and tear, damage, misuse or consumable parts.

This does not affect your statutory rights.

For Customer Services & Spare Parts please call **0345 209 7461**
Opening times: Monday - Friday 8am – 8pm & Saturday 9am – 1pm
Or visit us at **www.productcare.co.uk**

NOTES

GEORGE FOREMAN[®]

KETTLE BBQ - GFKTBBQ

Made by G2S under license.
G2S Ltd, Wigan, WN2 4AY
George Foreman is the registered trademark
of Spectrum Brands (U.K.) Ltd.

Revision 3.4