

Assembly Instructions

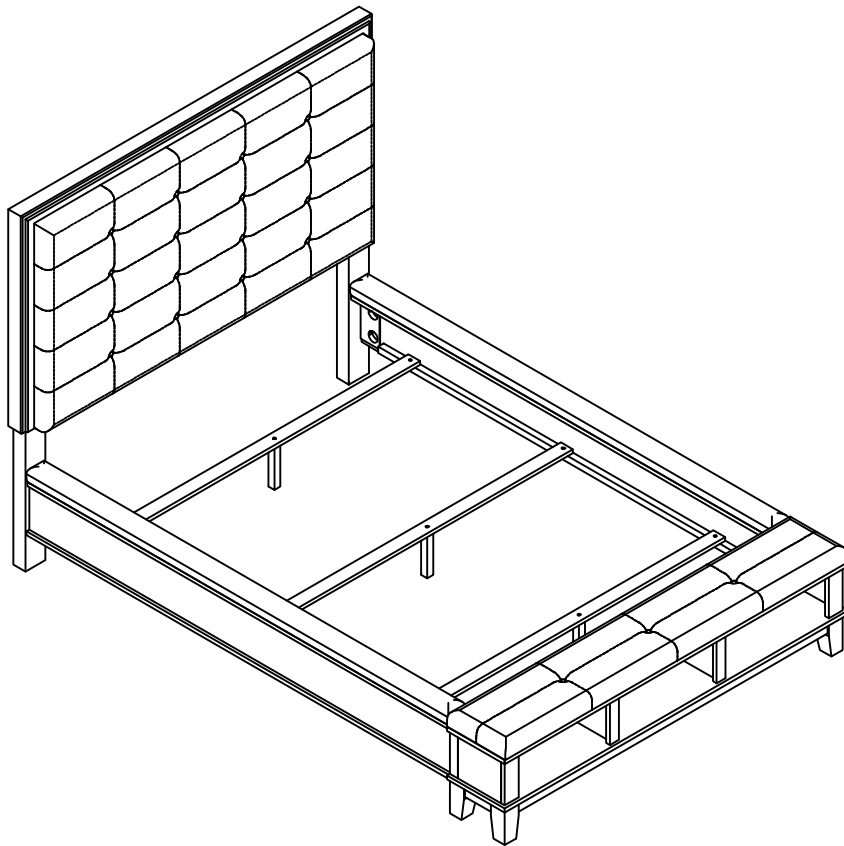

ASSEMBLY RATING

The Assembly Rating is a 5-point system that shows the degree of effort needed in assembling a specific product (with 1 being easy and 5 being difficult). For some products, two persons are recommended.

EASY  DIFFICULT

Tools Required For Assembly:

Allen Wrench

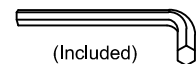

(Included)

Wrench

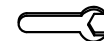

(Included)

Phillips Screwdriver



(Not Included)



2 PERSONS RECOMMENDED

ASSEMBLY & CARE ADVICE

FOR YOUR FURNITURE TO LAST, CORRECT ASSEMBLY AND PROPER MAINTENANCE ARE NECESSARY. PLEASE FOLLOW THE INFORMATION PROVIDED BELOW TO FULLY ENJOY YOUR FURNITURE.

BASIC ASSEMBLY TECHNIQUES

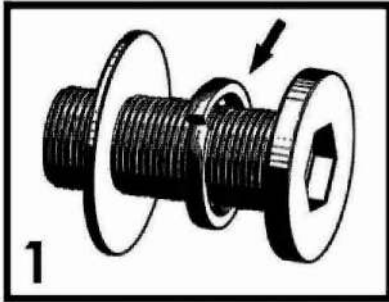

1
When lock or spring washer is used in an assembly, please make sure the lock or spring washer is placed between the larger flat washer and the head of the screw or bolt.

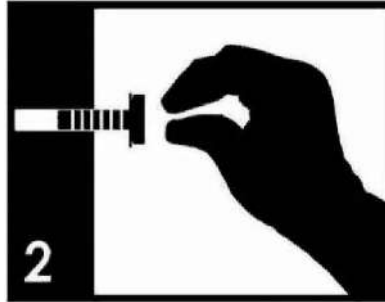

2
Position each part correctly and insert screws or bolts into their respective holes by hand tighten or using the proper hand tool. Only tighten when step is completed or when instructed to do so.

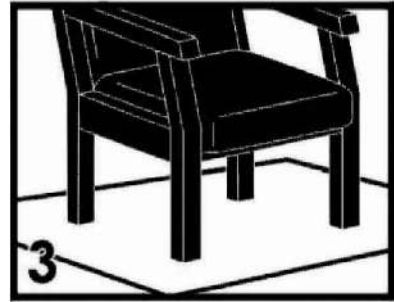

3
Use cardboard or carpet area when assembling furniture to prevent scratches. Make sure the furniture rests on a flat and level surface with each leg evenly touching the floor. No dragging of products/parts.

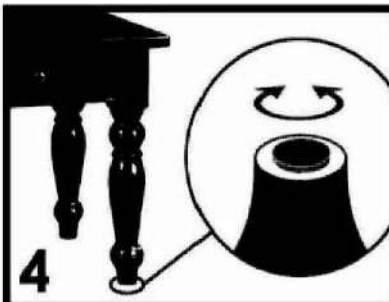

4
Some furniture comes with height adjustment knobs underneath each leg. To lower or to raise each leg, you need to turn clockwise or counterclockwise, respectively.

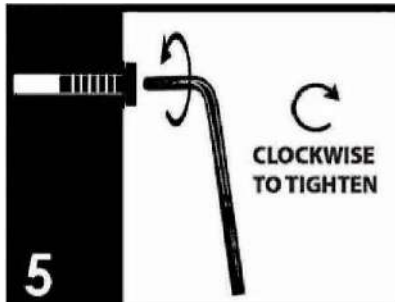

5
Make sure all parts are properly aligned, then use the appropriate hand tool to completely tighten the bolts or screws. Do not use power tools and do not overtighten.

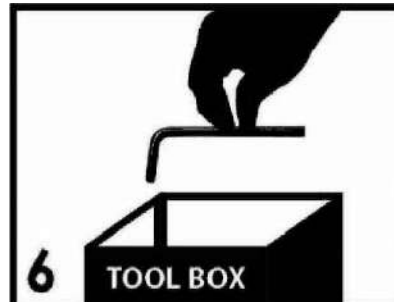

6
Save the instructions and store the Allen wrench or any supplied tool for later maintenance. After two weeks, check and tighten any loose hardware and repeat again every six months thereafter.

IT IS THE USER'S RESPONSIBILITY TO MAINTAIN THE FURNITURE. THE HARDWARE MAY LOOSEN OVER TIME AND MAY CAUSE THE FURNITURE TO BE WOBBLY AND UNABLE TO SUPPORT ITS INTENDED WEIGHT CAPACITY. THIS MAY LEAD TO COLLAPSE AND MAY CAUSE SERIOUS INJURY.



FAILURE TO FOLLOW THE GUIDELINES ABOVE MAY RESULT IN INJURY AND/OR PROPERTY DAMAGE.

ALL RIGHTS RESERVED.

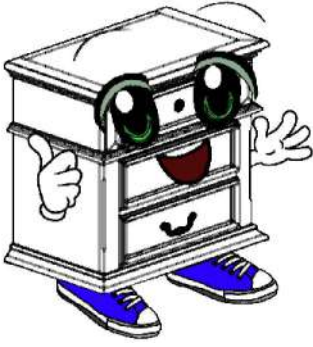

Before you begin, please read Page 2 of "Assembly and Care Advice".

And remember, do not tighten until each step is completed or instructed.

Parts List

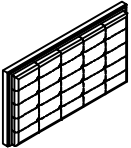
- 

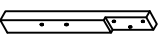
#1 x 1pc
Headboard
- 

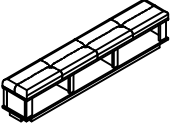
#2 x 2pcs
Headboard Leg(L&R)
- 

#3 x 1pc
Footboard
- 

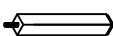
#4 x 4pcs
Footboard Leg
- 

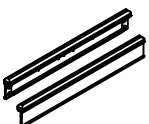
#5 x 1pc $\text{Ø}1/4"$
FB Support Leg 124x30x30mm
- 

#6 x 2pcs
Side Rail
- 

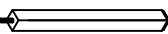
#7 x 3pcs
Slat
- 

#8 x 3pcs $\text{Ø}1/4"$
Support Leg 193x30x30mm

Hardware List

- 

#A x 6pcs
Bolt $\text{Ø}5/16"$ x 2-3/8"
- 

#B x 8pcs
Bolt $\text{Ø}5/16"$ x 2"
- 

#C x 14pcs
Lock Washer $\text{Ø}5/16"$
- 

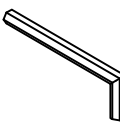
#D x 14pcs
Flat Washer $\text{Ø}5/16"$
- 

#E x 1pc
Allen Key 4mm
- 

#F x 8pcs
Threaded Stud $\text{Ø}5/16"$ x 3-1/2"
- 

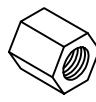
#G x 8pcs
Half Moon $\text{Ø}5/16"$
- 

#H x 8pcs
Hex nut $\text{Ø}5/16"$

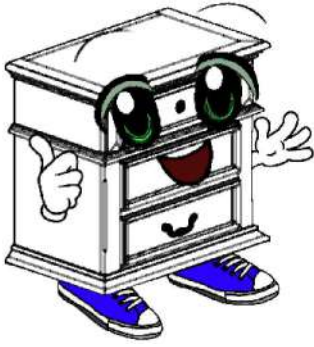

Before you begin, please read Page 2 of "Assembly and Care Advice".

And remember, do not tighten until each step is completed or instructed.

Hardware List



#I x 1pc
Wrench 12mm



#J x 6pcs
Screw #8 x 32mm

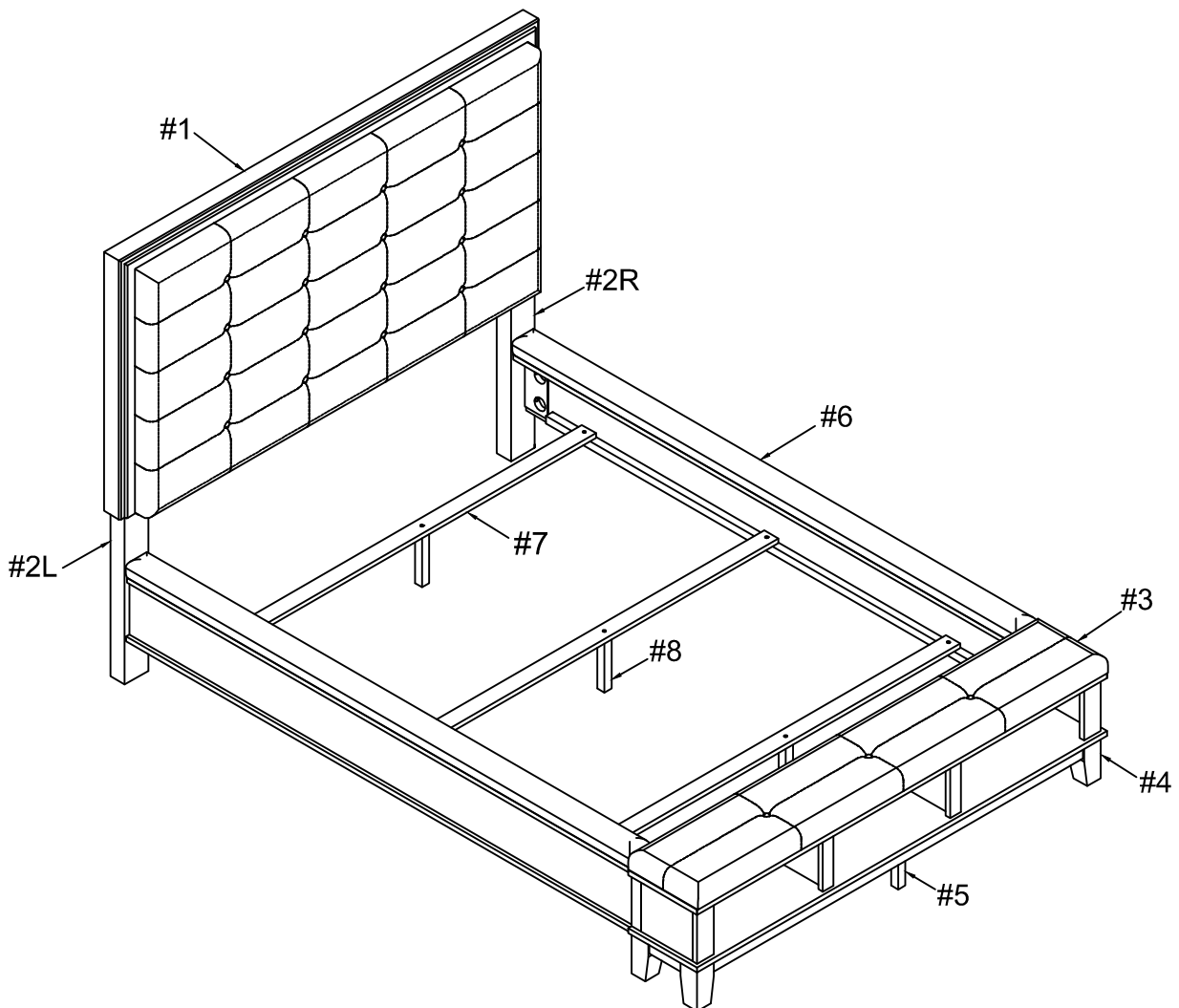



#A x 6pcs
#C x 6pcs
#D x 6pcs

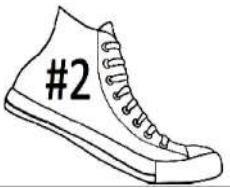
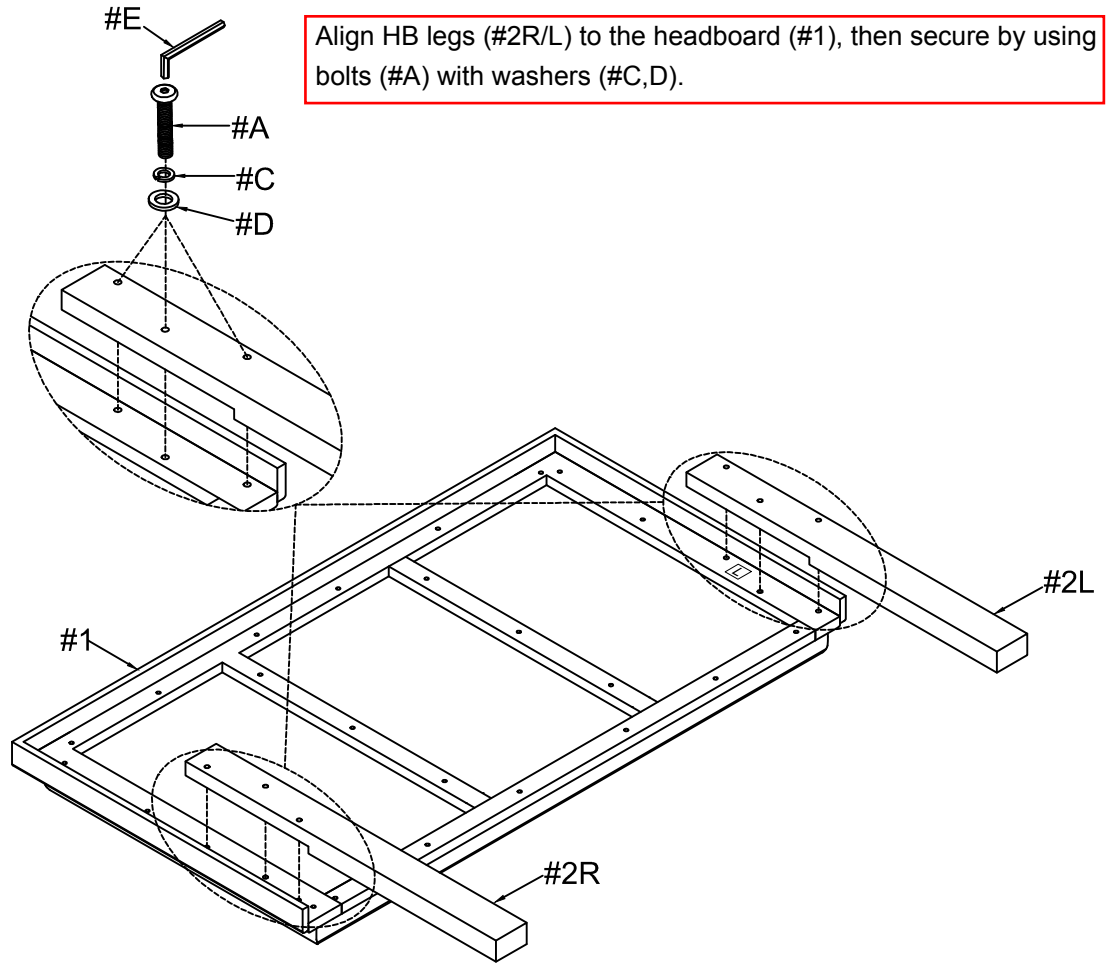

#B x 8pcs
#C x 8pcs
#D x 8pcs

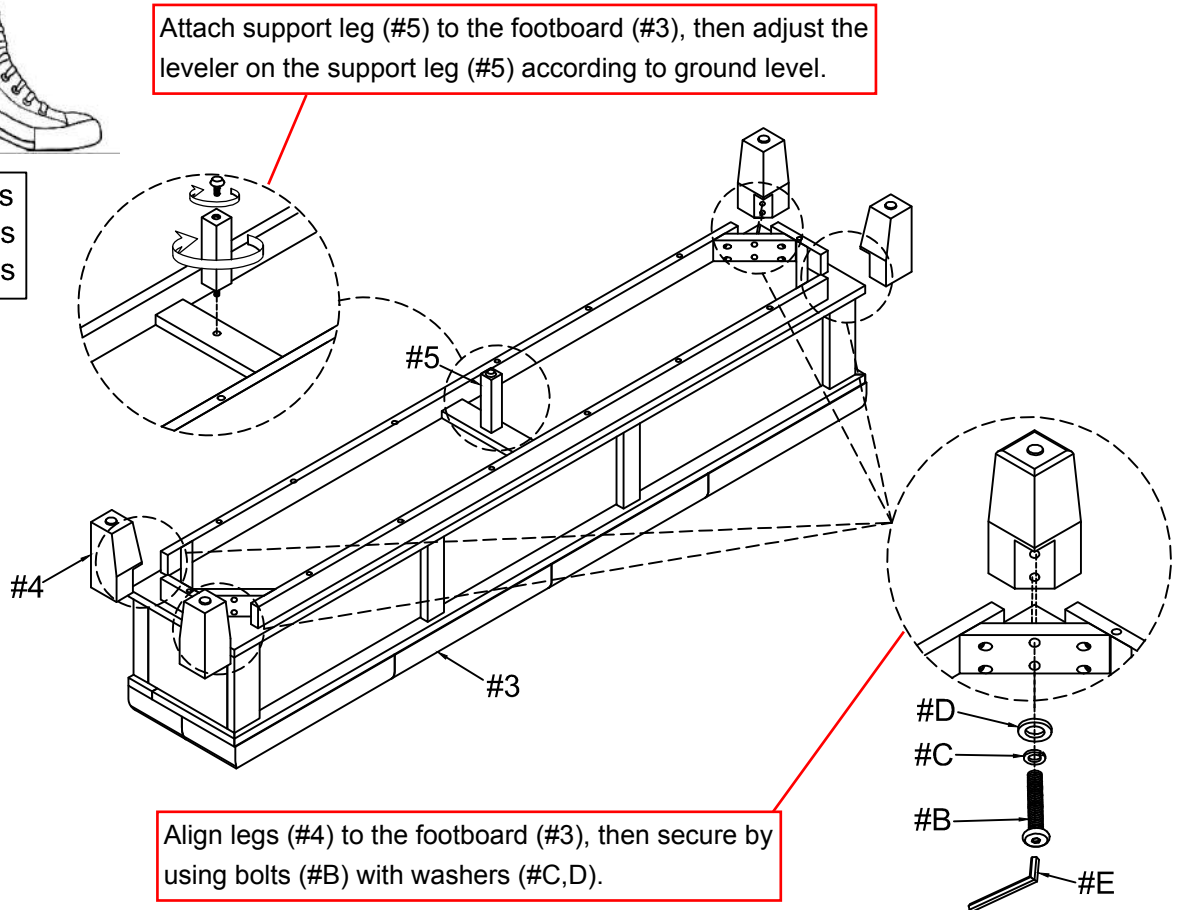

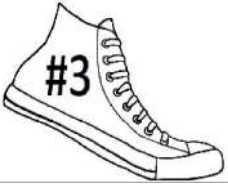

Attach threaded studs (#F) to the headboard (#1) and footboard (#3), then align the side rails (#6) to the threaded studs (#F) attached to the headboard (#1) and footboard (#3). Secure by using hex nut (#H) with washers (#G).

#F x 8pcs
#G x 8pcs
#H x 8pcs

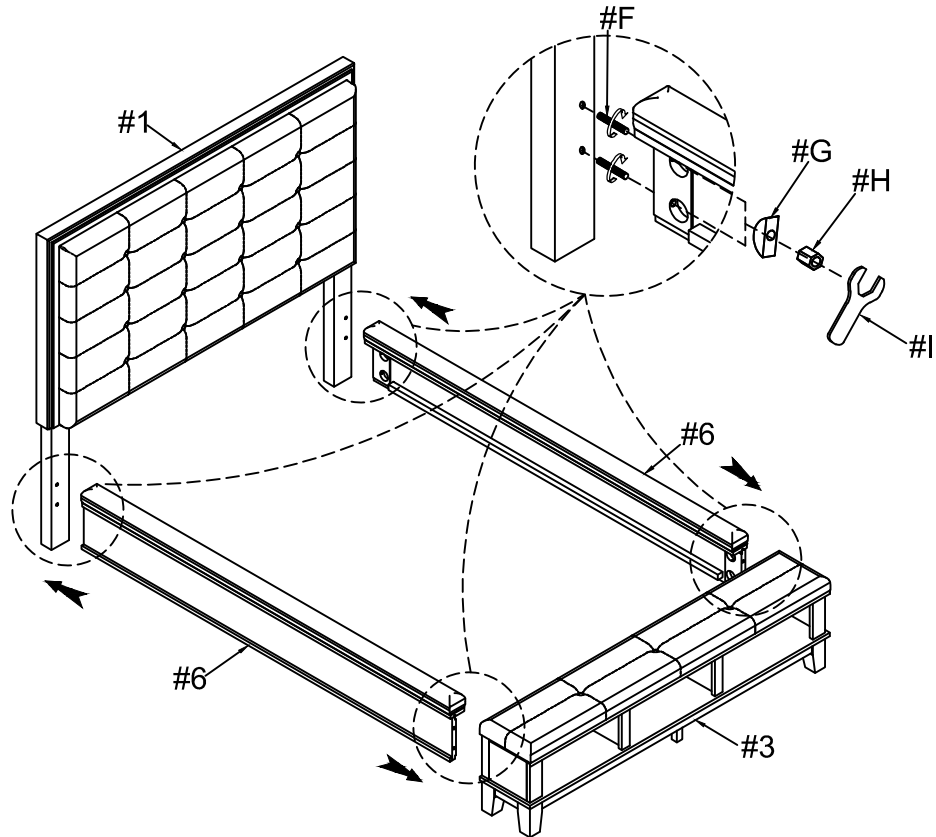

Attach support legs (#8) to the slats (#7). Adjust the levelers on the support legs (#8) according to ground level.

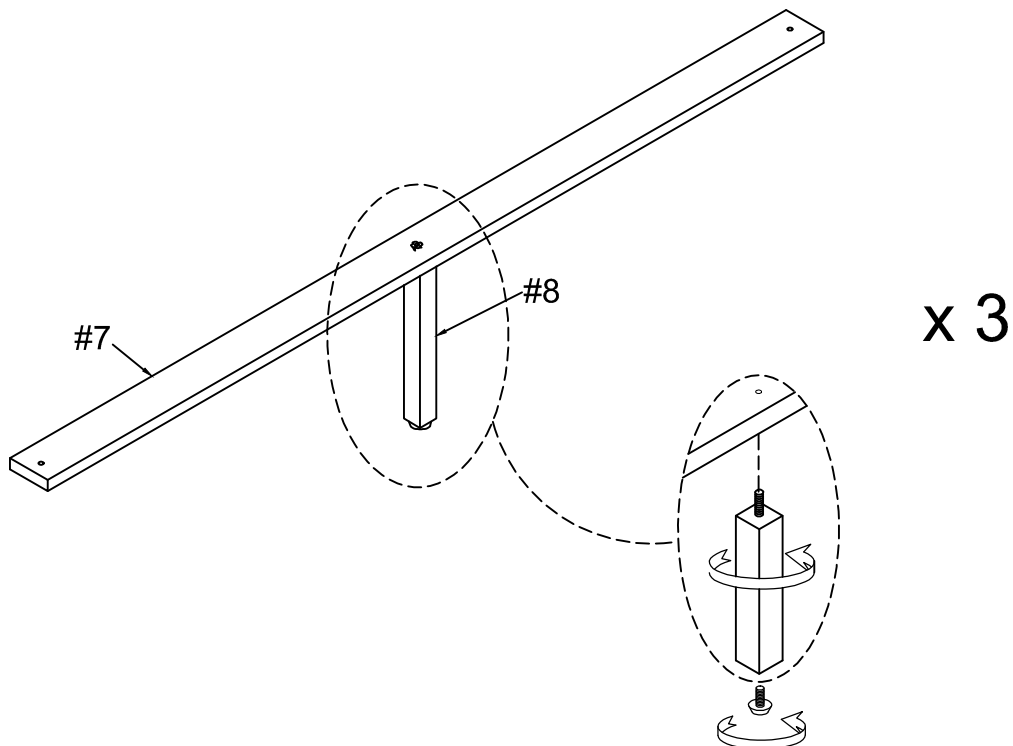



Align slats (#7) to the side rails (#6), then secure by using screws (#J).

#J x 6pcs

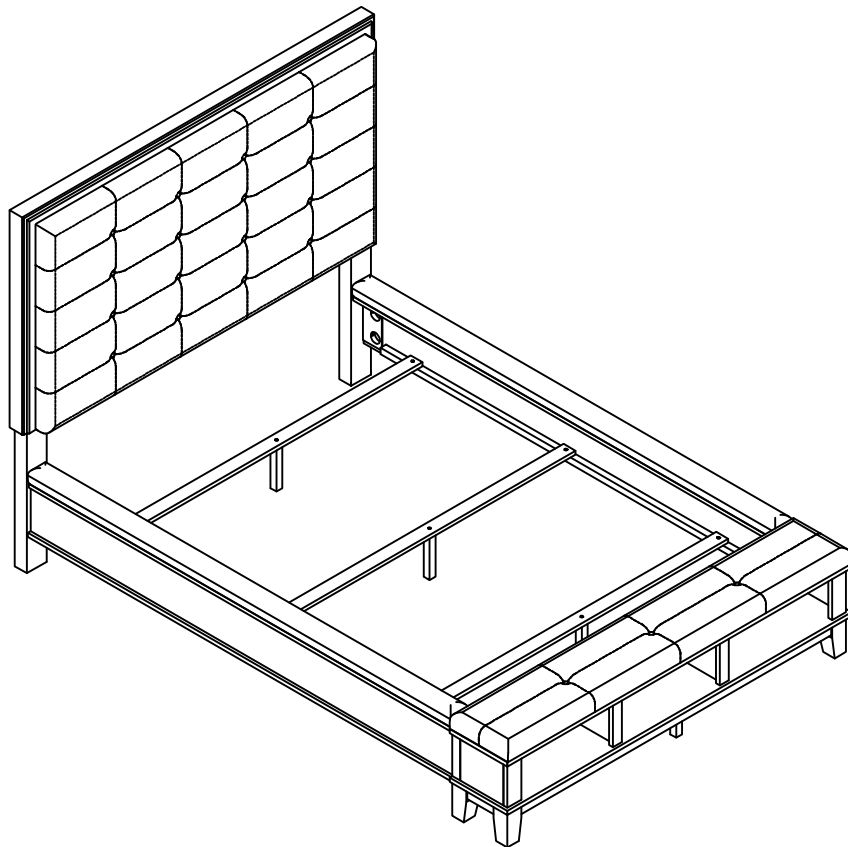
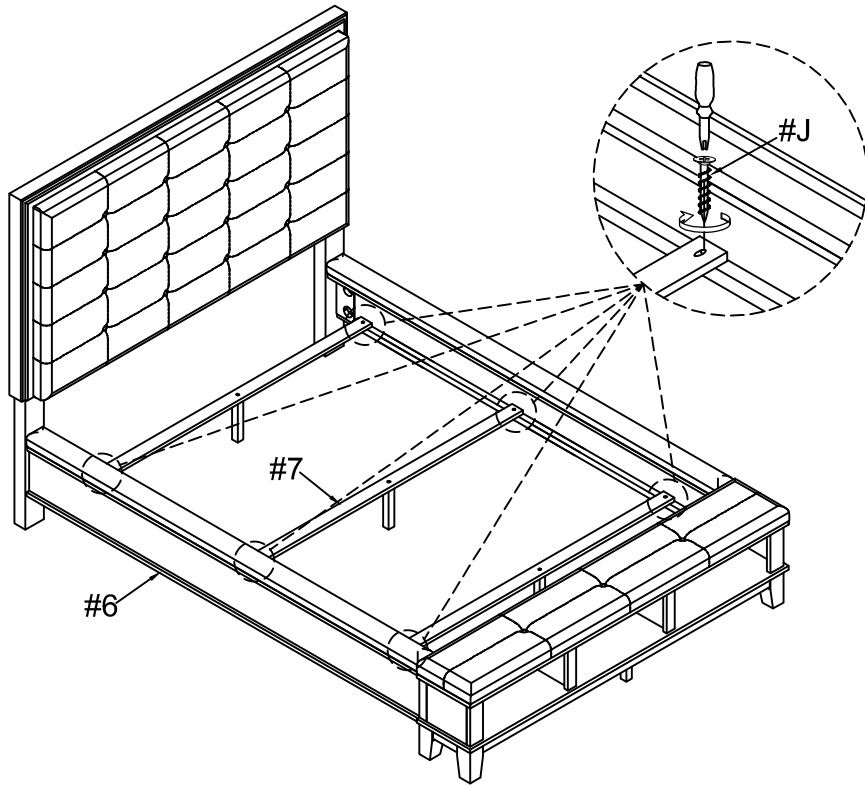

ASSEMBLY IS COMPLETED