

Assembly Instructions

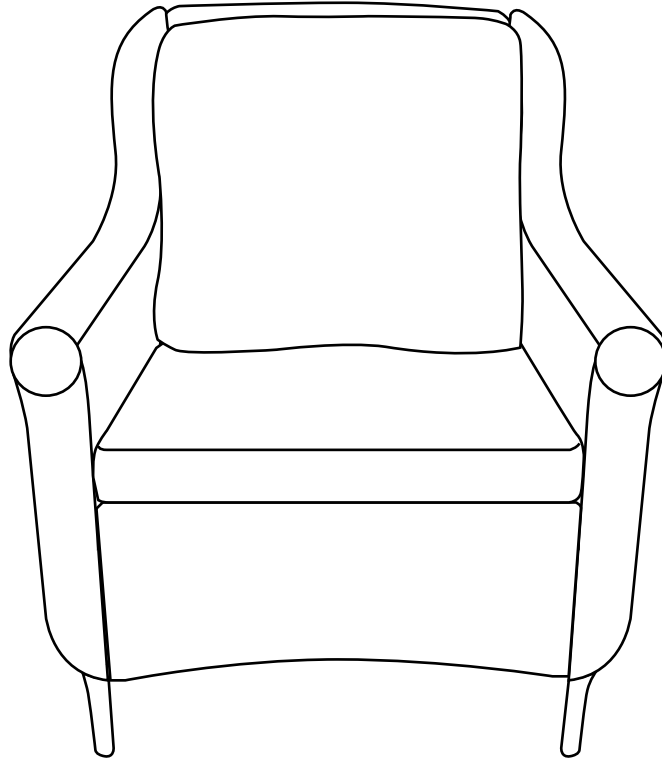

***Don't fully tighten all the bolts till the very end!**

PRE-ASSEMBLY PREPARATION:

- A cordless drill is recommended for ease of assembly.
- Clear out the space for assembly and lay out all of the parts based on the Parts List, extra room will allow you to easily determine if all the pieces are present.
- Keep small parts and pieces away from children until fully assembled.

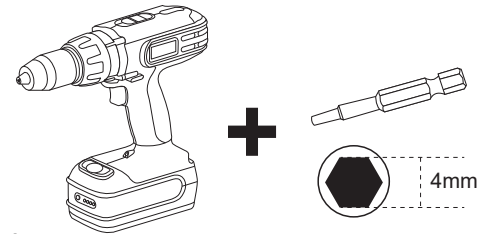

A1

**Left
Arm
1pc**

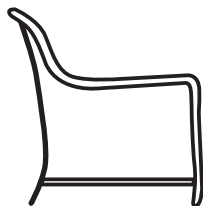

C

**Front
1pc**



A2

**Right
Arm
1pc**

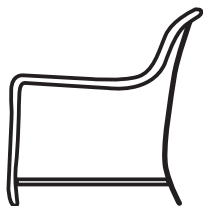

D

**Seat
1pc**

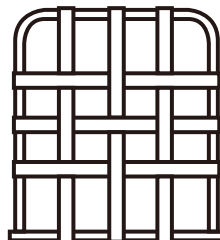

B

**Back
1pcs**

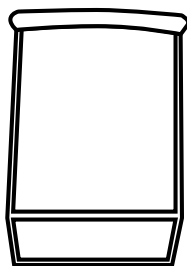

|+J

**Seat
Cushion
Back
Cushion
1pc**

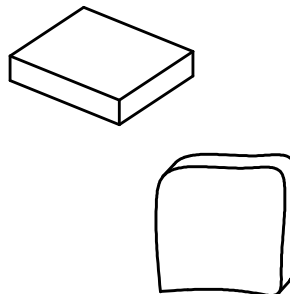

Step 1 :Attach arms A1&A2 to back panel B with 4pcs bolts E and 4pcs washers G,using Allen Wrench H. Note: Please don't fully tighten the bolts.

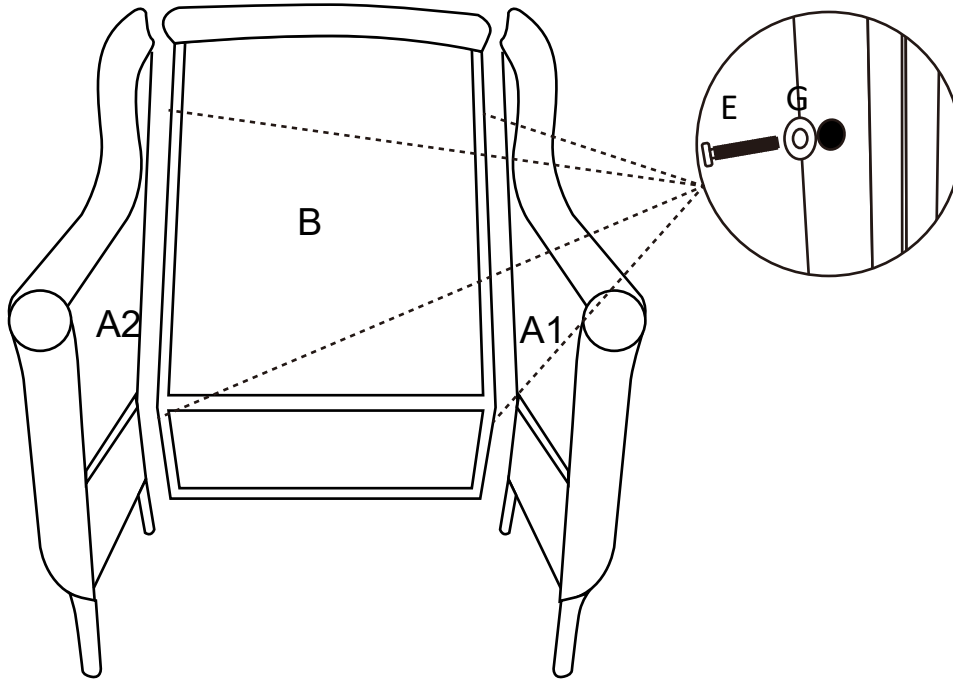

Step 2 :Attach front panel C to arms A1&A2 with 4pcs bolts E and 4pcs washers G, using Allen wrench H. Note: Please don't fully tighten the bolts.

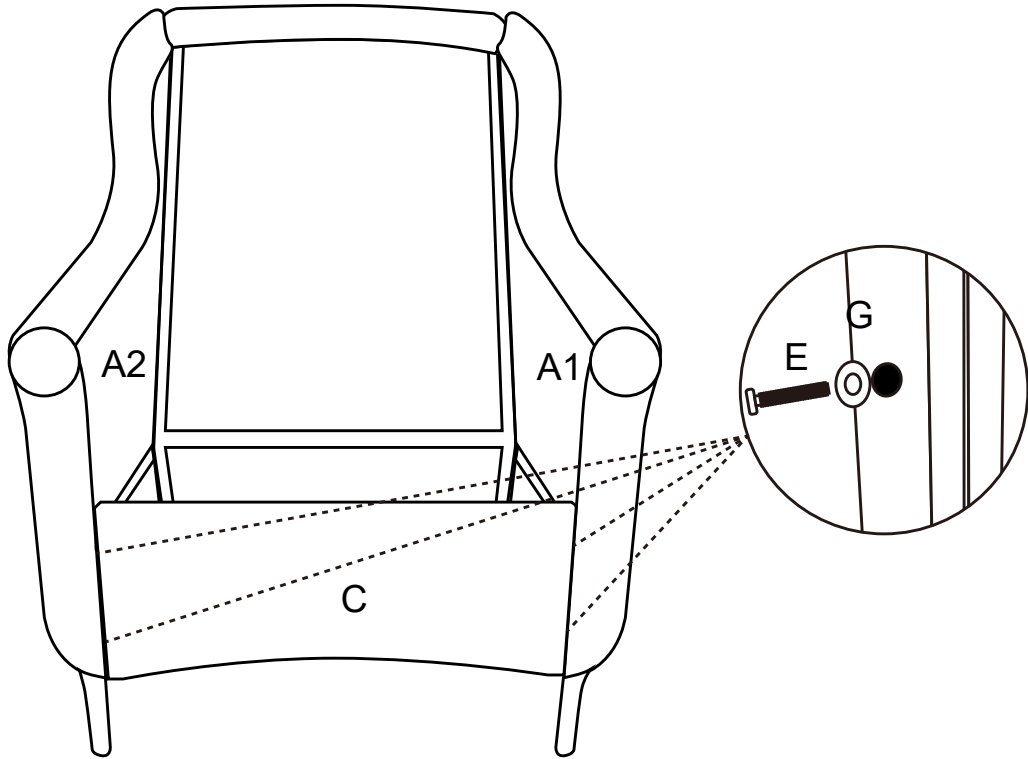

Step 3

:Attach seat D to back panel and front panel with 4pcs bolts E and 4pcs washer G ,using Allen wrench H. Note: Please don't fully tighten the bolts.

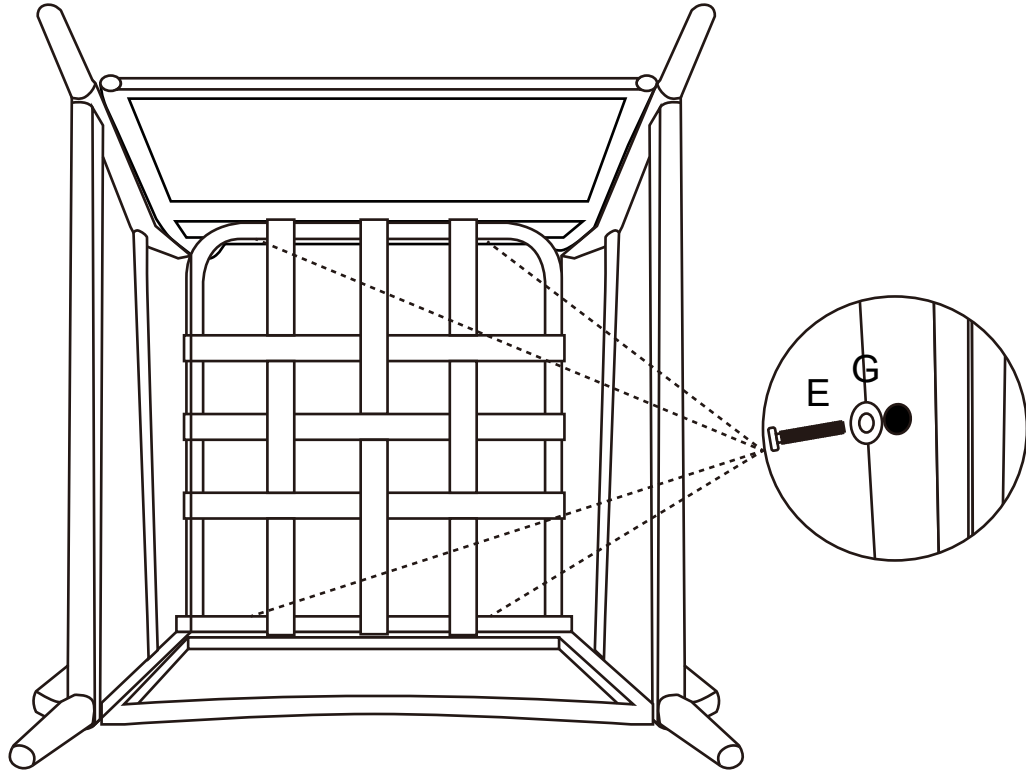

Step 4 :Put the seat cushion I and back cushion J onto the seat .Assembly is now complete and the product is ready for use.

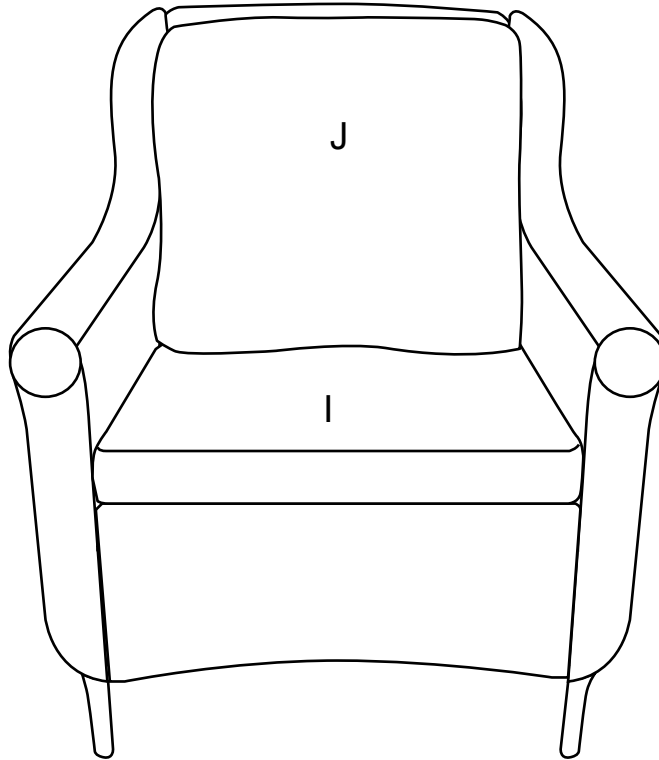

SPECIAL WARNING:

THIS CHAIR IS NOT A TOY. DON'T OVER-SWING THE CHAIR .OVER-SWING THE CHAIR MAYBE MAKE THE CAHIR TIP OVER AND RESULT IN INJURY. DO NOT STAND ON THE CHAIR . Any improper use of this product may result in injury .

