

ASSEMBLY INSTRUCTION

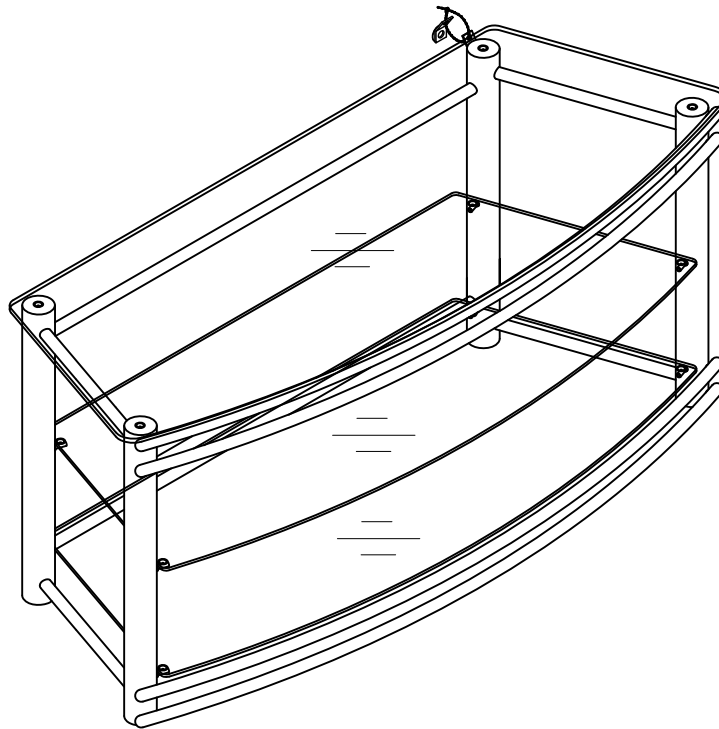

Do not tighten screws until completely assembled.

ASSEMBLY INSTRUCTIONS

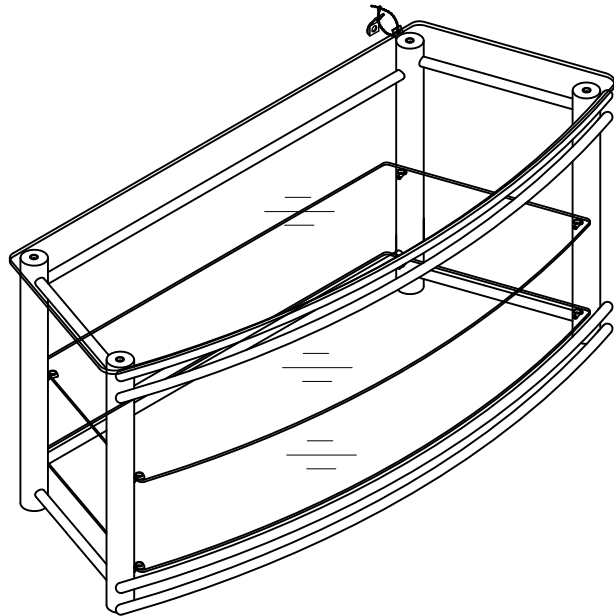

CAUTION:
DO NOT FULLY TIGHTEN
SCREWS UNTIL FULLY ASSEMBLED

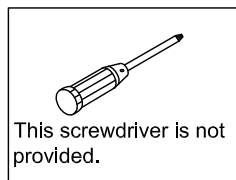

PARTS IDENTIFICATION

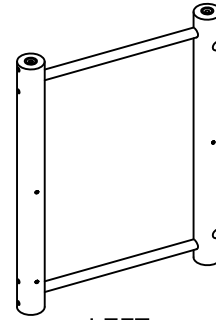

LEFT
(1) x 1pc

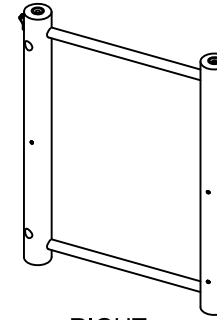

RIGHT
(2) x 1pc

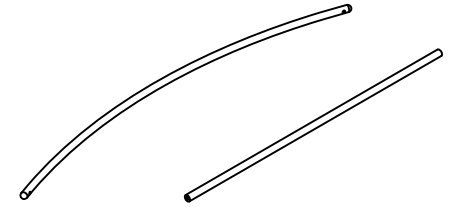

(3) x 4pcs

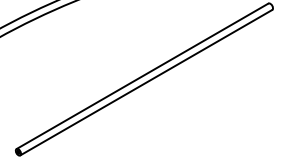

(4) x1pc

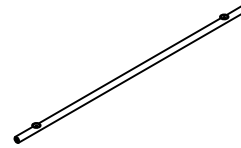

(5) x 1pc

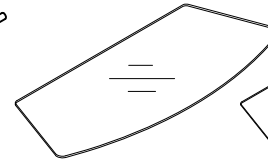

TOP
(6) x 1pc

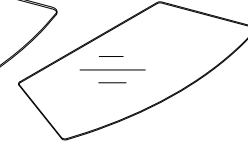

MIDDLE
(7) x 1pc

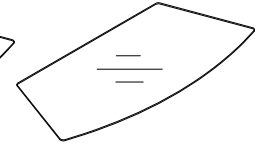

BOTTOM
(8) x 1pc

HARDWARE LIST

A  1/4"x2 1/2" 8pcs

B  1/4"x7/8" 4pcs

C  6pcs

D  6pcs

E  1pc

F  1pc

G  1pc

H  M4x37mm 1pc

J  4x4mm 1pc

STEP 1:

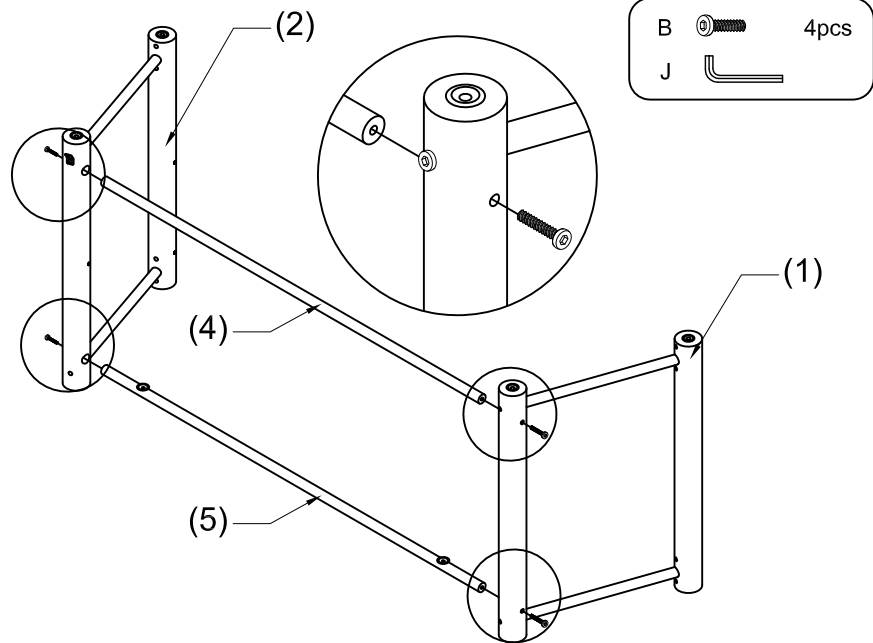

STEP 3:

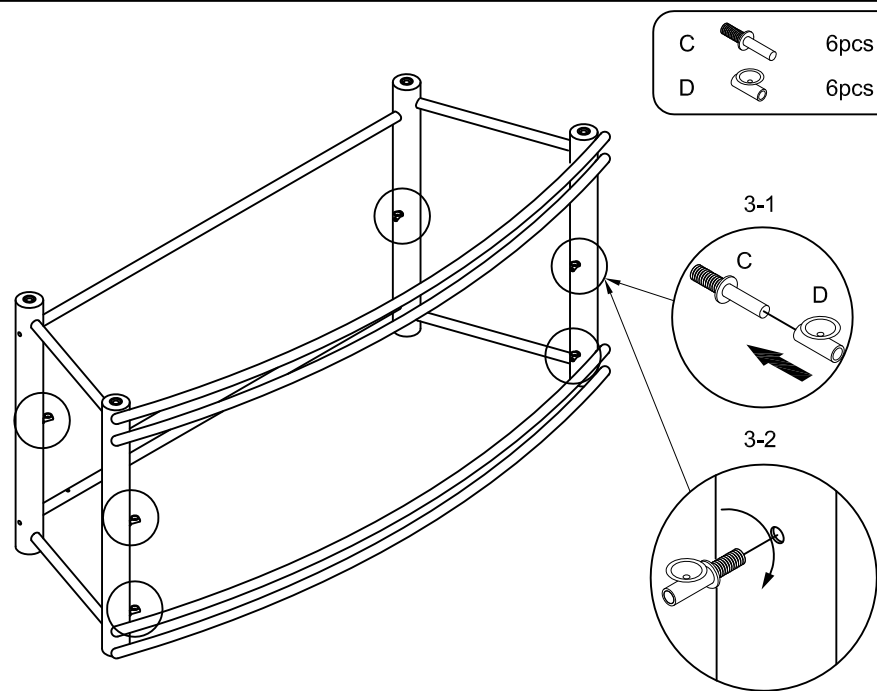

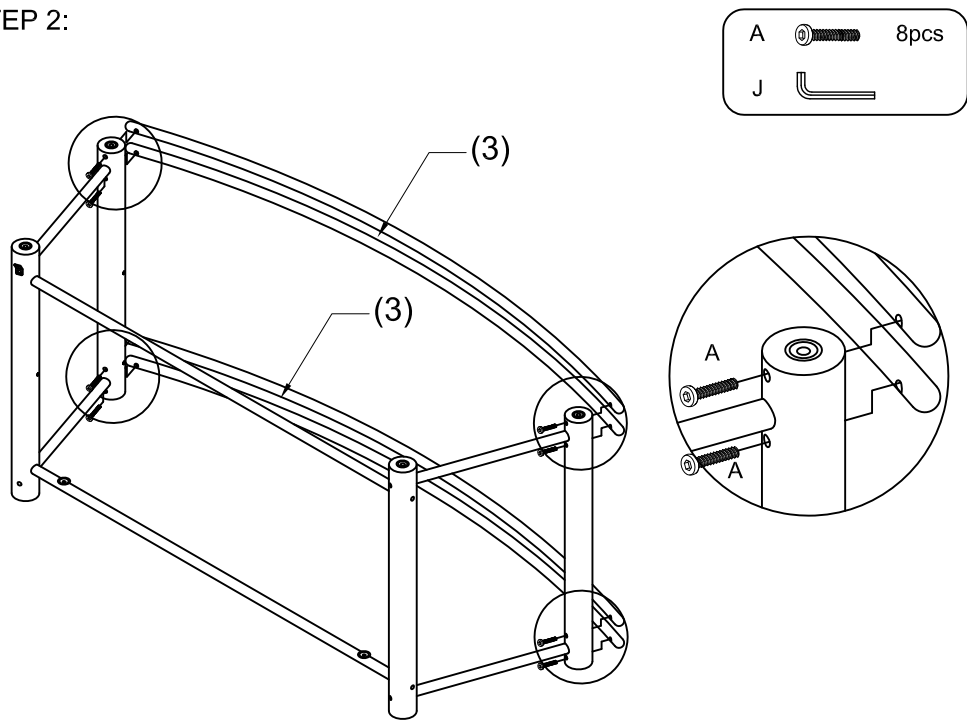

STEP 2:

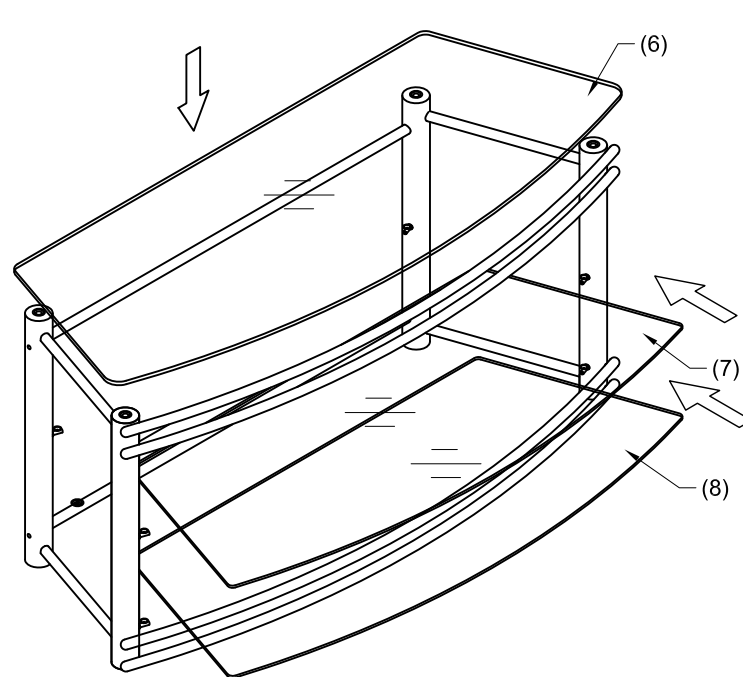

STEP 4:



STEP 5:

E		1PC
F		1PC
H		1PC

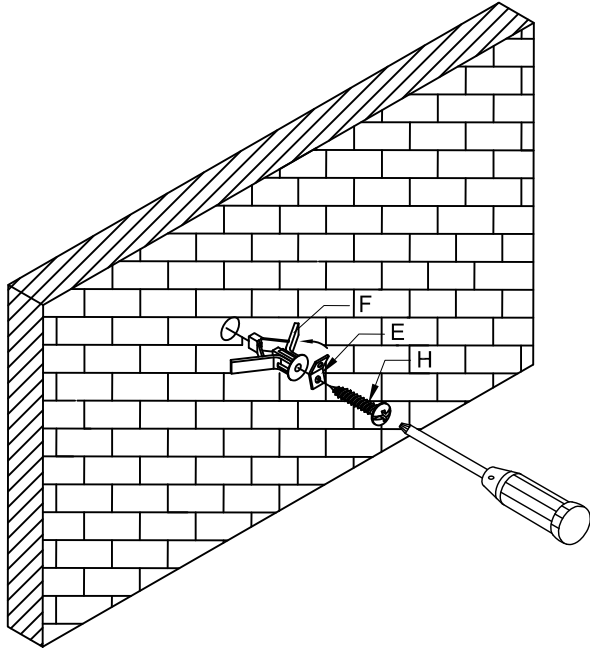

STEP 6:

G		1pc
---	--	-----

TO PREVENT TIP OVER
PRODUCT MUST BE
ATTACHED TO WALL

