

ASSEMBLY INSTRUCTIONS

COFFEE TABLE

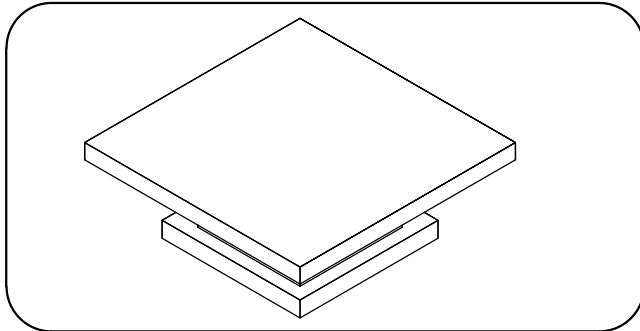

+ Do Not Use
Power Tools

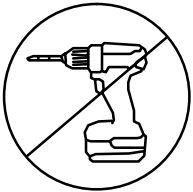

+ Suggested
Adults

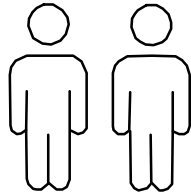

NOTE:

- 1 Read instructions cover to cover.
- 2 Save all packaging until assembly is completed.

1 IMPORTANT SAFETY INFORMATION

Do not assemble the product if any of the following parts arrived damaged:

- Part 1 - Top panel
- Part 2 - center panel
- Part 3 - Base

Do not assemble if any of the following Hardware parts are missing:

- Part A - Bolt
- Part B - Spring washer
- Part C - Flat washer
- Part D - Allen wrench
- Part E - Dowels

2 IMPORTANT ASSEMBLY INFORMATION

Assembly Step If loosening persists, please make sure to tighten all the bolts periodically, or use a thread locker adhesive.

+ Parts Included

- ① Top panel
1pc

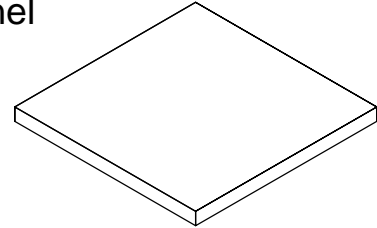

- ② center panel
1pc

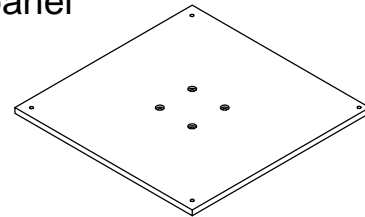

- ③ Base
1pc

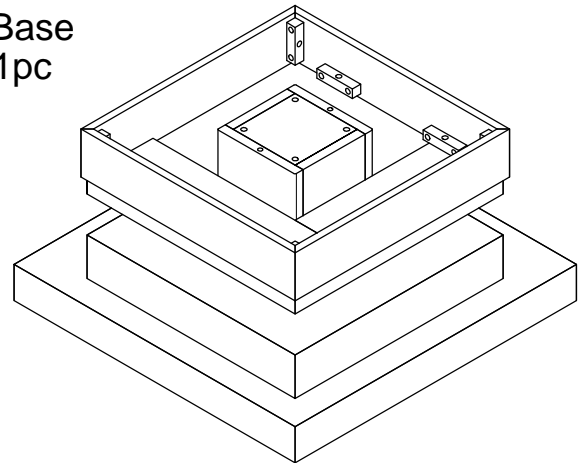

+ Hardware Included

- A Bolt $\Phi 5/16"$ x 1 1/2" (8pcs)

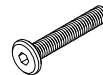

- B Spring washer $\Phi 5/16"$ x $\Phi 13$ x1mm
(8pcs)



- C Flat washer $\Phi 5/16"$ x $\Phi 19$ x 2mm
(8pcs)



- D Allen wrench (4mm) (1pc)



- E Dowels F8 x 30mm (2pcs)



ASSEMBLY INSTRUCTIONS

COFFEE TABLE

①

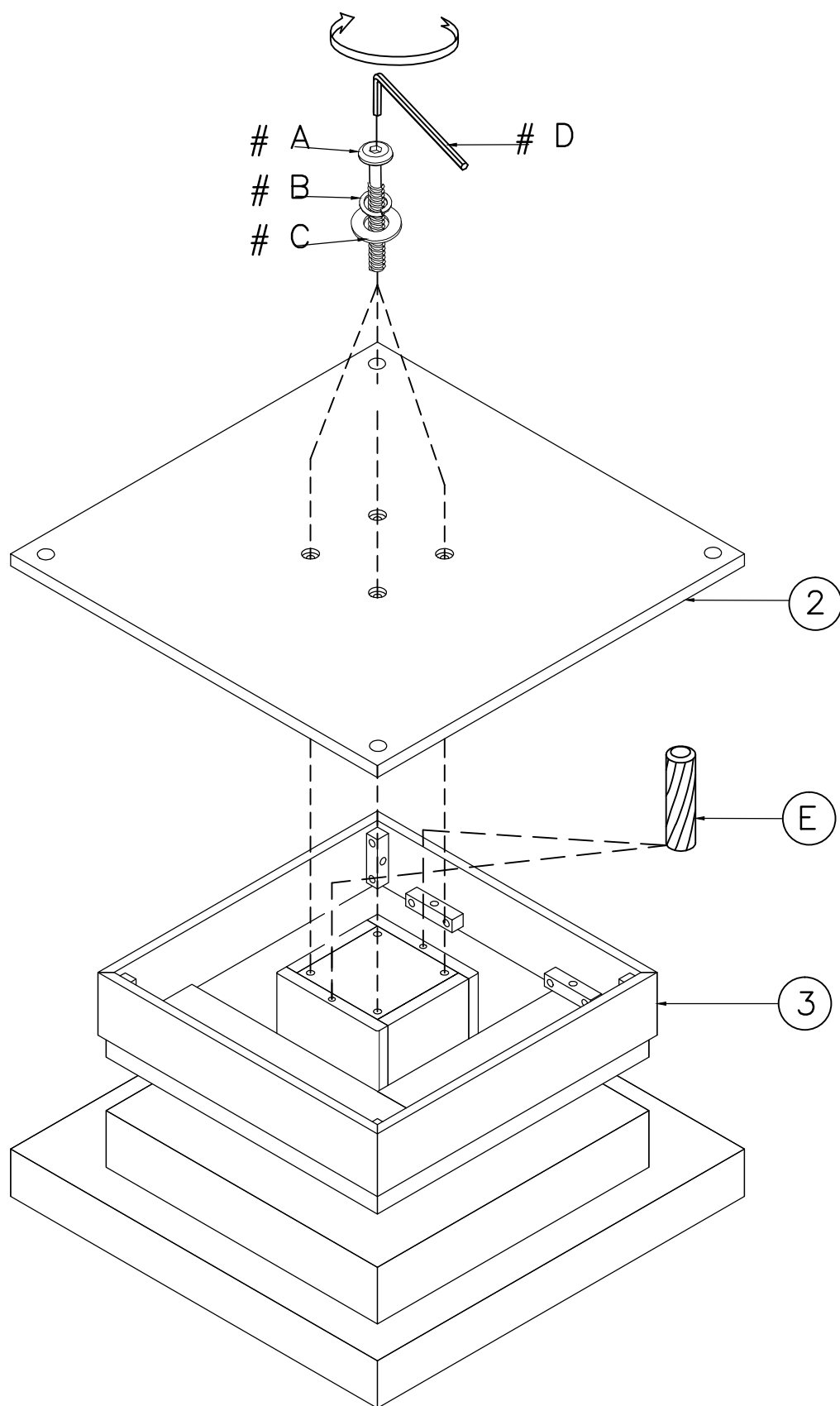

ASSEMBLY INSTRUCTIONS

COFFEE TABLE

2

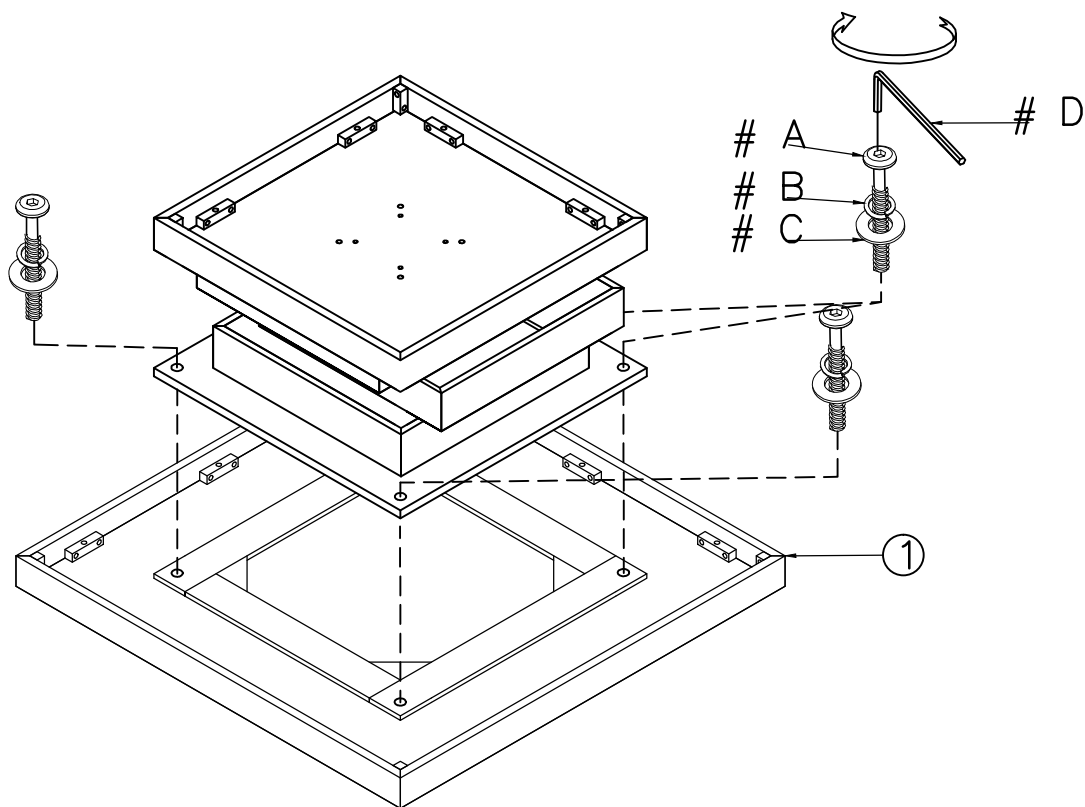

Assembly complete.

