

ASSEMBLY INSTRUCTIONS

TOOLS REQUIRED



Allen Wrench

(Included)



**Philips
Screwdriver**

(Not Included)

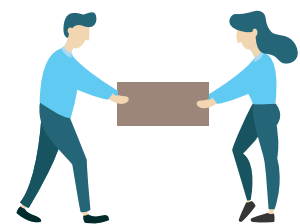
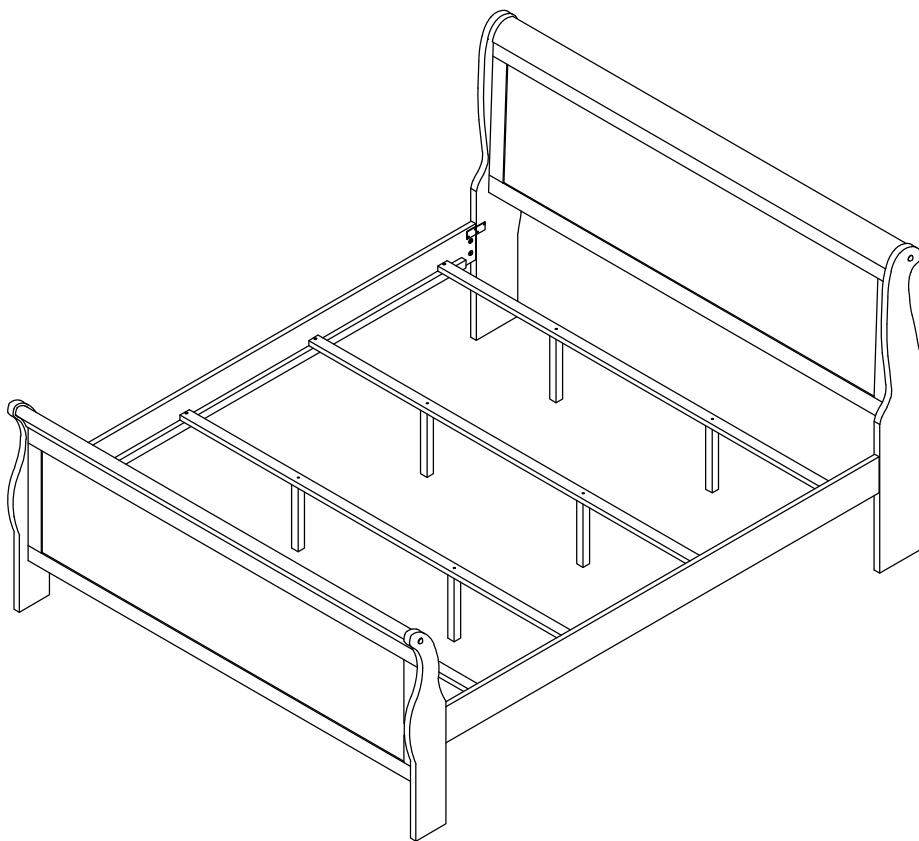

**2 - People
Recommended**

ASSEMBLY RATING



EASY —————> DIFFICULT

The Assembly Rating is a 5-point system showing the level of effort needed to assemble a specific product.



CHECK BEFORE STARTING

Are you missing anything?

Double-check all parts, hardware and accessories listed on Page 6 are accounted for.

Should we send any replacements?

Are there any irregularities or flaws in the parts? We can send replacements!

Check out our Quick Tips!

We recommend reviewing the pre-assembly handouts. Even experts need a refresher now and then!

Prep Time!

Please review the assembly instructions and all diagrams prior to assembling. Arrange parts as recommended on Page 7 and group identical hardware together to make assembling easier.

PRE ASSEMBLY INTRODUCTION

We understand building ready-to-assemble furniture can be a challenging experience for some. To help avoid confusion, we have provided some helpful tips that may speed up the process.



Teamwork

ALWAYS have at least two people to help with transporting and assembling the product to avoid potential injury and/or damage.



Suitable Location

Assembling near the area of the intended location is highly recommended.



Sufficient Space

Make sure you have enough space to move around during the assembly.



Avoid Scratches

Use cardboard, blankets or a carpeted area while assembling furniture to prevent scratches.



Flat Surface

Make sure the furniture rests on a flat and level surface with each leg evenly touching the floor.

ASSEMBLY AND CARE ADVICE



FAILURE TO FOLLOW THE GUIDELINES BELOW MAY RESULT IN INJURY AND/OR PROPERTY DAMAGE.



Position each part correctly and insert screws or bolts into their respective holes.

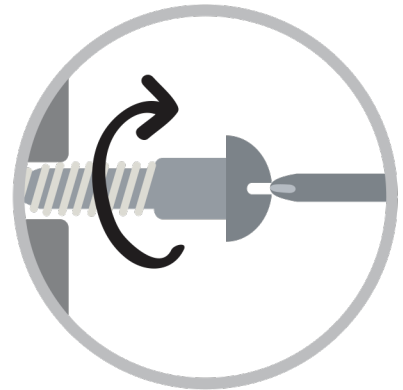

Turn clockwise to tighten and only tighten when step is completed or when instructed to do so.



Use the appropriate hand tools or power tools for assembly. Select steps, such as tightening screws and/or bolts, may require hand tools to avoid causing damage during assembly.



Save the instructions and store any supplied tools for later maintenance.

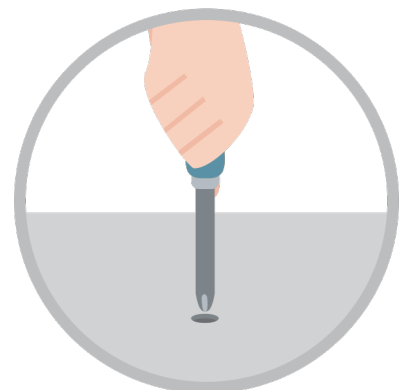

After two weeks, check and tighten any loose hardware and repeat again every six months thereafter.

IT IS THE USER'S RESPONSIBILITY TO MAINTAIN THE FURNITURE. THE HARDWARE MAY LOOSEN OVER TIME AND MAY CAUSE THE FURNITURE TO BE WOBBLY AND UNABLE TO SUPPORT ITS INTENDED WEIGHT CAPACITY. THIS MAY LEAD TO COLLAPSE AND MAY CAUSE SERIOUS INJURY.

KING SIZE BED



- Please keep instructions for future reference.
- Check the quantity and irregularity of parts and hardware before you start.

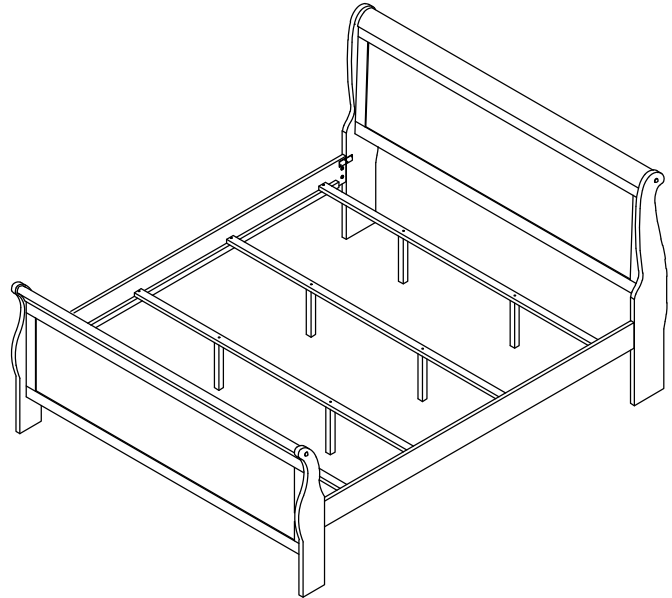

PARTS

#1 1pc

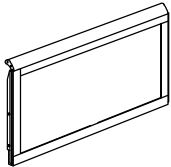

Headboard Panel

#2 1pc

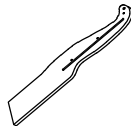

Headboard Leg Right

#3 1pc

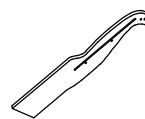

Headboard Leg Left

#4 1pc

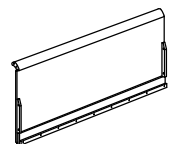

Footboard

#5 1pc

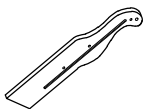

Footboard Leg Right

#6 1pc

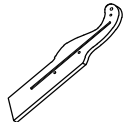

Footboard Leg Left

#7 2pcs

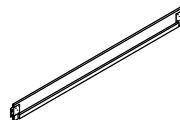

Side Rail

#8 4pcs

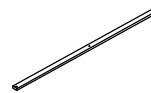

Slat
18mm x 45mm
x 1947mm

#9 8pcs

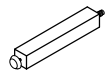

Slat Support Leg
29mm x 29mm
x 248mm

HARDWARE

#A 4pcs

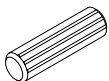

Dowel M10 x 40mm

#B 4pcs

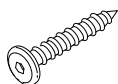

JCBC-W M7 x 40mm

#C 8pcs

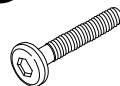

Bolt 1/4" x 1-3/8"

#D 8pcs



Lock Washer

#E 8pcs



Flat Washer

#F 1pc



Allen Wrench

#G 4pcs



Wood Button Ø14.5

#H 8pcs



CSK M4 x 32mm

#I 16pcs



CSK M3.5 x 16mm

#J 4pcs

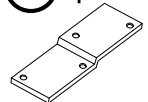

Bracket - Black

ASSEMBLY INSTRUCTIONS

1

- Part #1 x1pc
- Part #2 x1pc
- Part #3 x1pc
- Hardware #A x2pcs

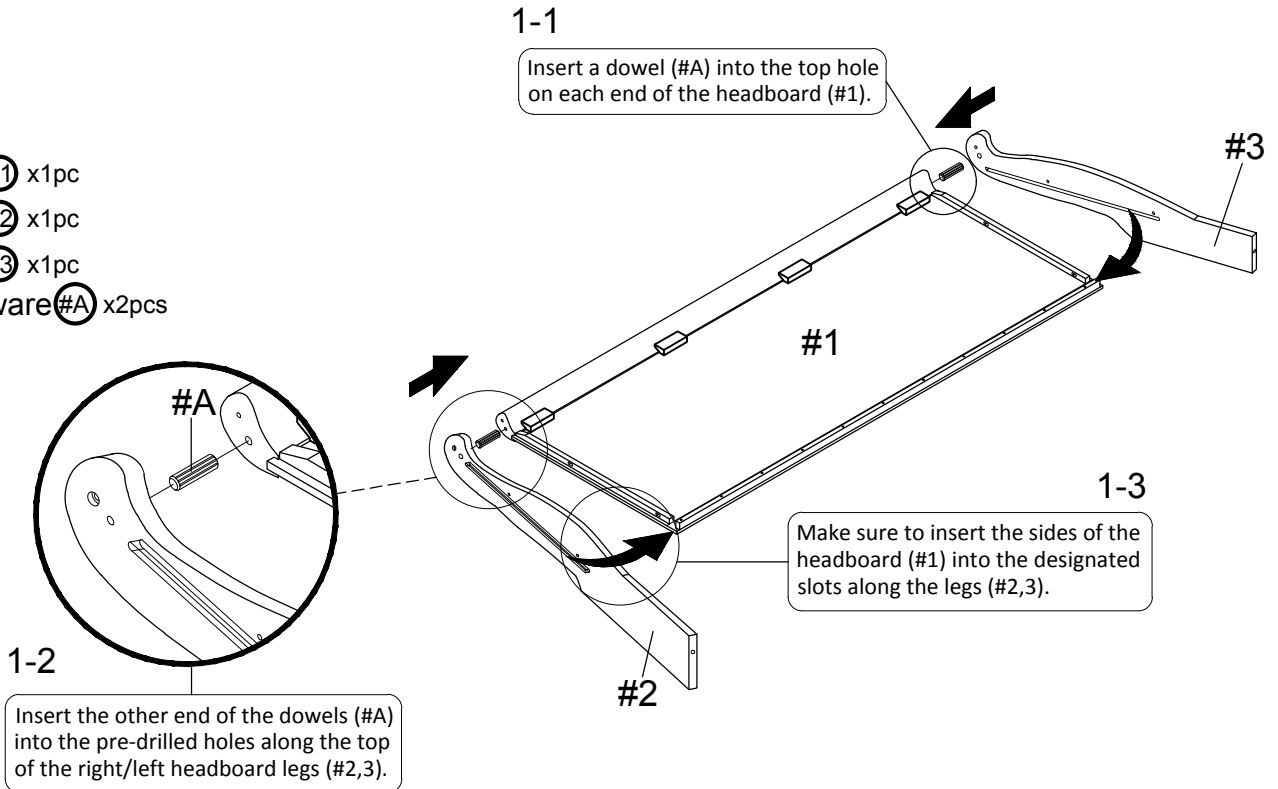

2

- Hardware #B x2pcs
- Hardware #C x4pcs
- Hardware #D x4pcs
- Hardware #E x4pcs
- Hardware #G x2pcs

2-2

Prepare 4 bolt assemblies by first inserting a lock washer (#D) onto the bolt (#C) then a flat washer (#E) onto that same bolt (#C), in that order. Insert the prepared bolts into the holes along the inner sides of the headboard (#1).

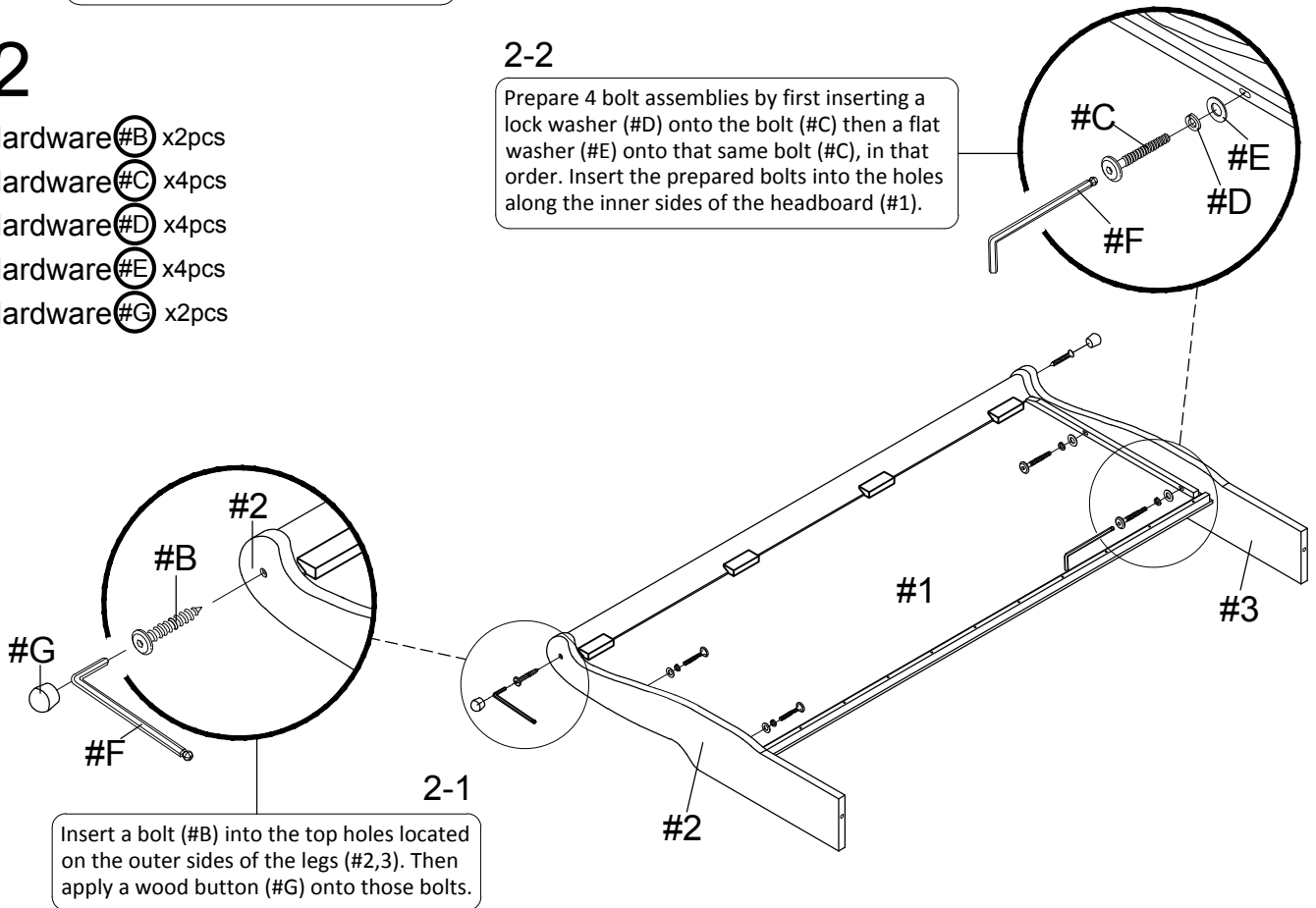

ASSEMBLY INSTRUCTIONS

3

- Part #4 x1pc
- Part #5 x1pc
- Part #6 x1pc
- Hardware #A x2pcs

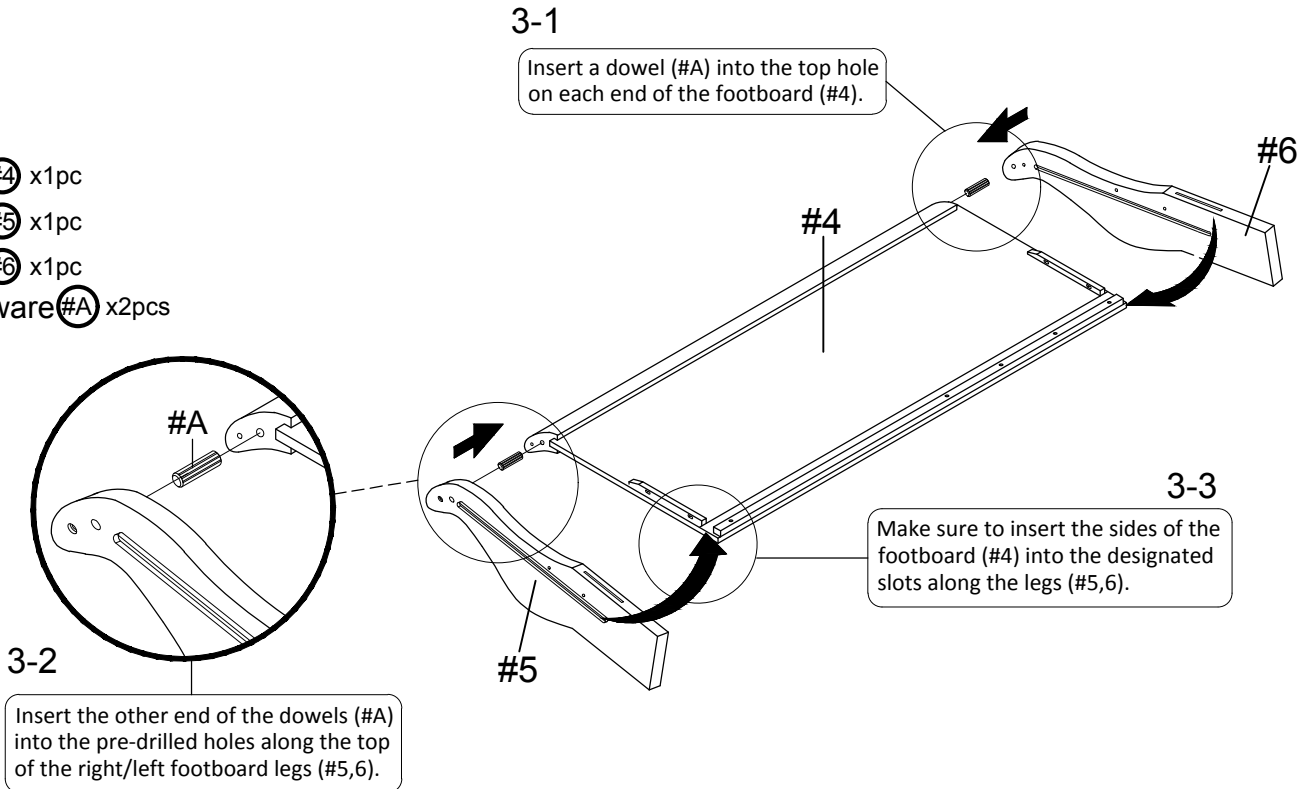

4

- Hardware #B x2pcs
- Hardware #C x4pcs
- Hardware #D x4pcs
- Hardware #E x4pcs
- Hardware #G x2pcs

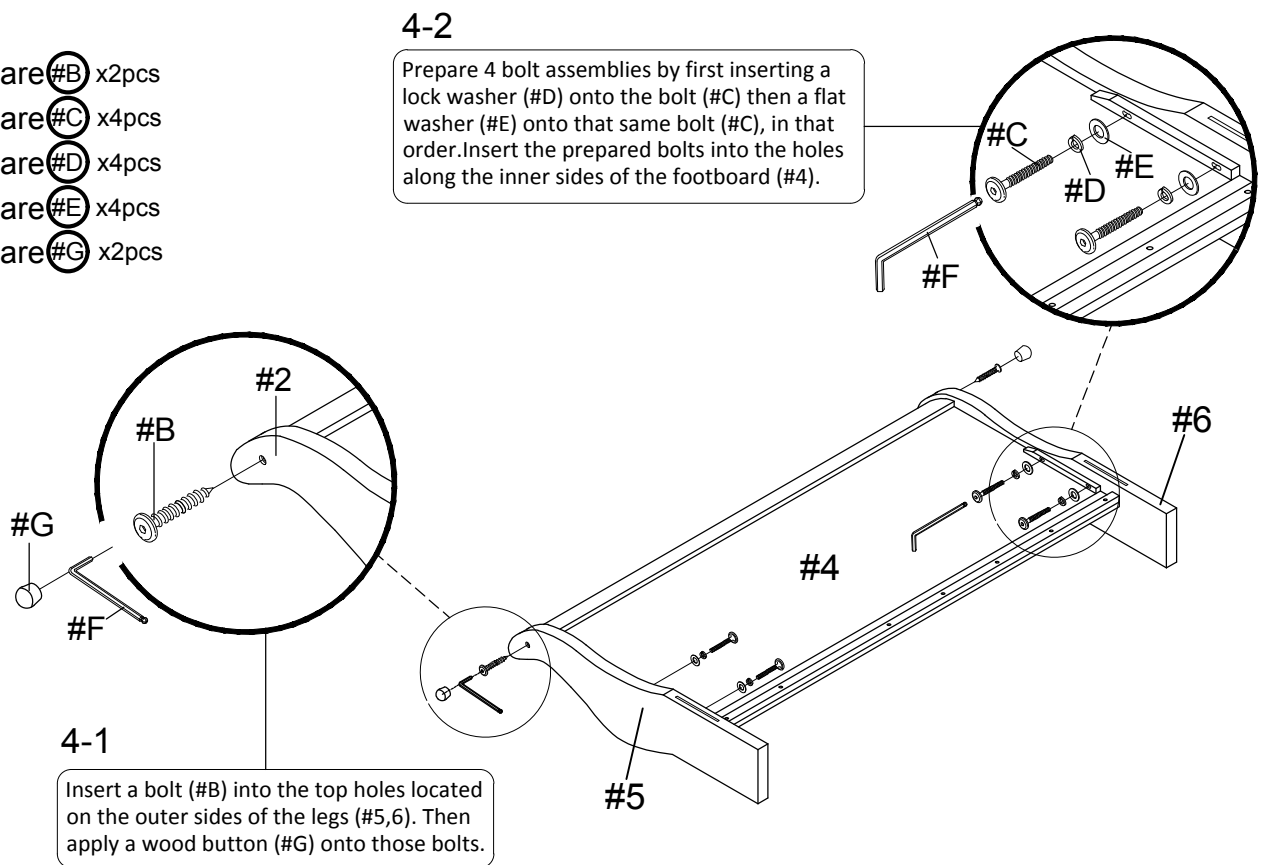

ASSEMBLY INSTRUCTIONS

5

Part #7 x2pcs
 Hardware #I x16pcs
 Hardware #J x4pcs

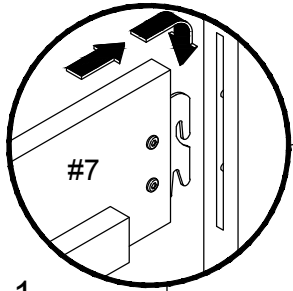

5-1
 Hook the ends of the side rails (#7) into the slots along the head-board/footboard legs.

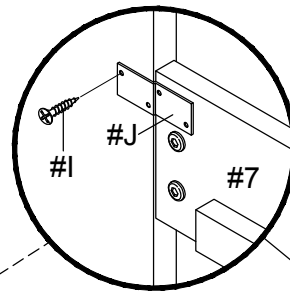

5-2
 Align the brackets (#J) to each rail end and footboard/head-board. Insert 4 screws (#I) into each bracket and secure using a Phillips screwdriver.

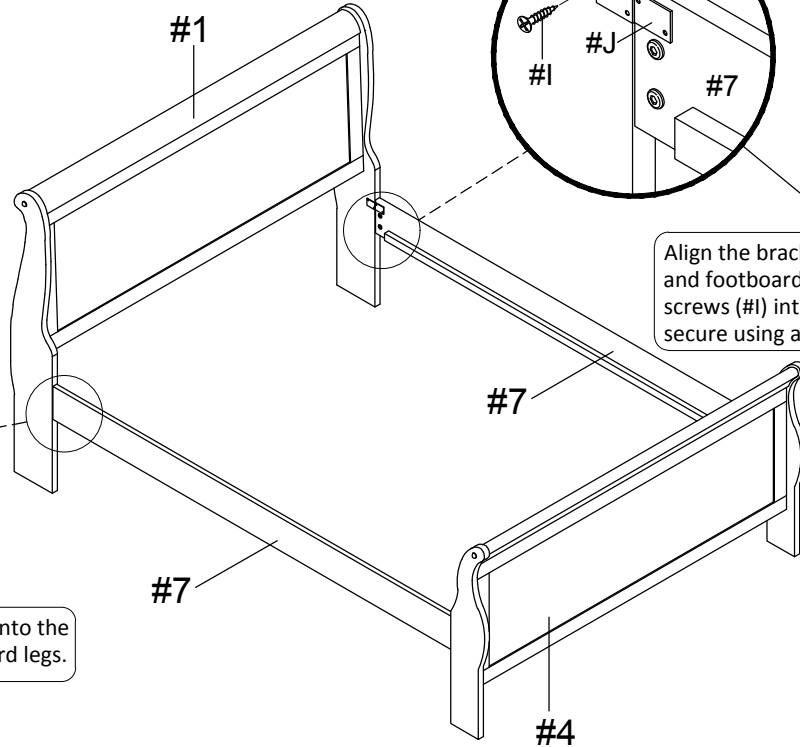

6

Part #8 x4pcs
 Part #9 x4pcs
 Hardware #H x8pcs

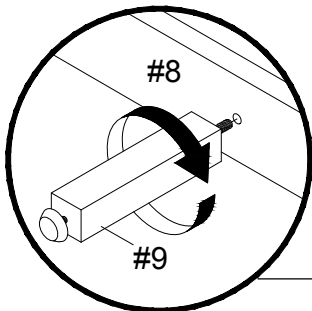

6-1
 Insert the threaded ends of the slat support legs (#9) into the pre-drilled holes along the sides of the slats (#8).

6-2
 Insert a screw (#H) into each end of the slats (#8). Secure using a Phillips screwdriver.

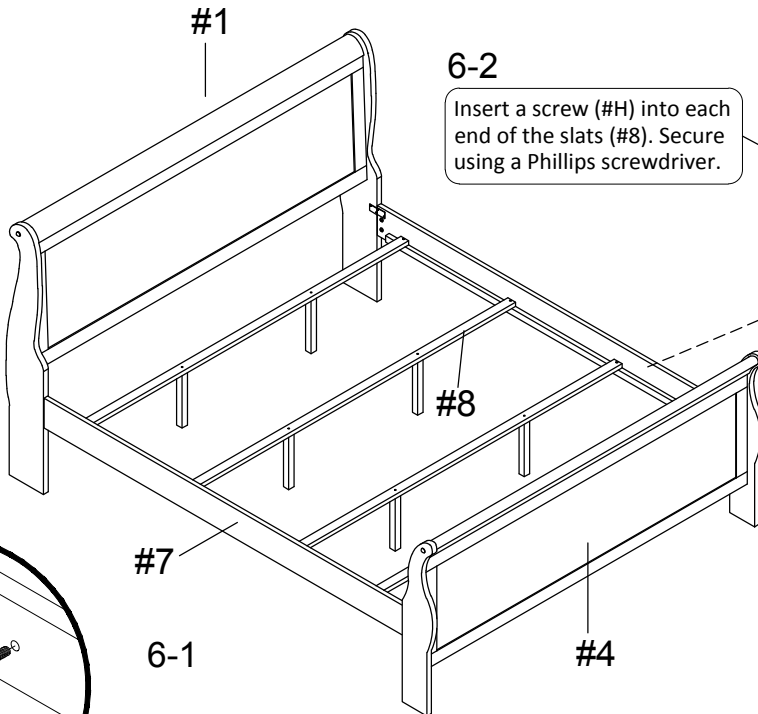
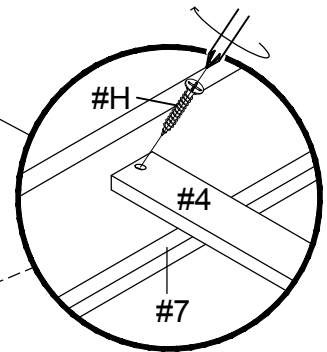

ASSEMBLY COMPLETED

Please ensure the furniture rests on an even and flat surface. If the product wobbles or feels loose, double-check all bolts and/or screws are properly tightened and secured.

- ✔ **Keep this handy!**
 Please retain this instruction manual and any order-related information for future reference.
- ✔ **Lift, don't drag!**
 To avoid damage to product please always LIFT the product when transporting or adjusting the placement.