

ASSEMBLY INSTRUCTION

SELF ASSEMBLY



1 Person build
Estimated build time
15 min.



ACHTUNG! CAUTION! DIKKAT!

Beim Aufbau dieses Mbelestcks liegt die alleinige Verantwortung bei der Person, die diesen Aufbau durchfhrt. Alle Bauteile samt Zubehr mssen bitte genauestens nach Montageanleitung zusammengefhrt werden.

It is the responsibility of the persons assembling the furniture to properly install all components and hardware as specified in these instructions. Please follow strictly the order of assembly shown in these instructions.

Bu talimatlarda belirtildiđi gibi tm bileenleri ve donanımı dzgn bir ekilde monte etmek mobilyaları monte eden kiilerin sorumluluđundadır. Ltfen bu talimatlarda gsterilen montaj sırasını harfiharfine uygulayın.

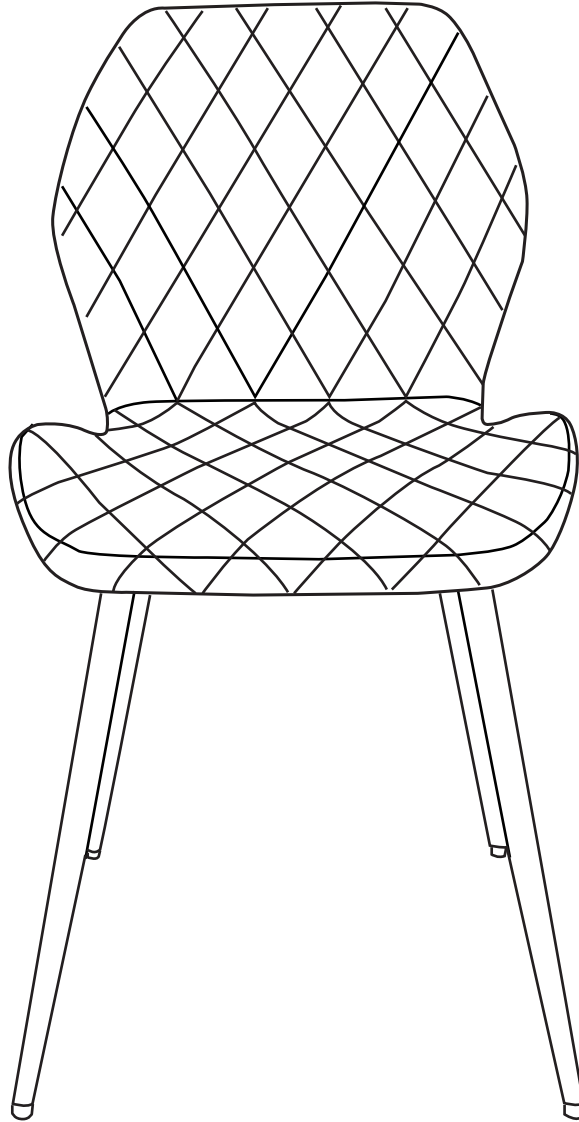

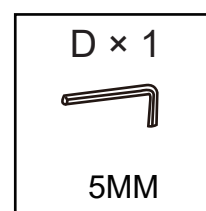
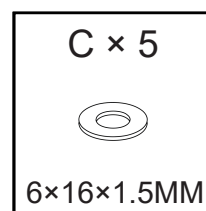
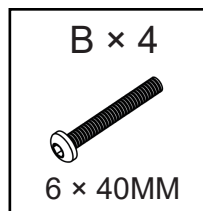
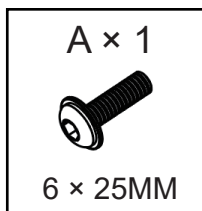
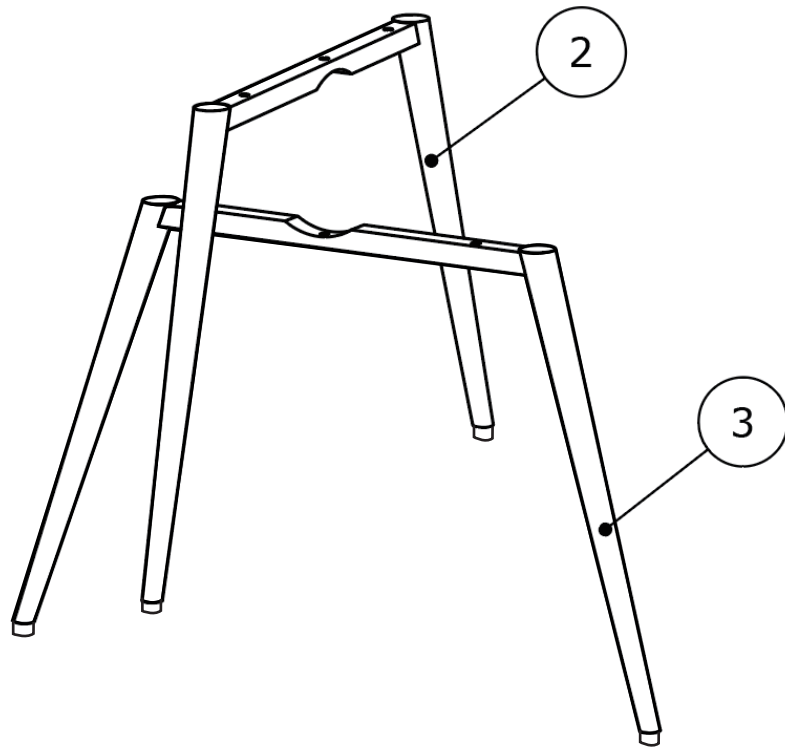
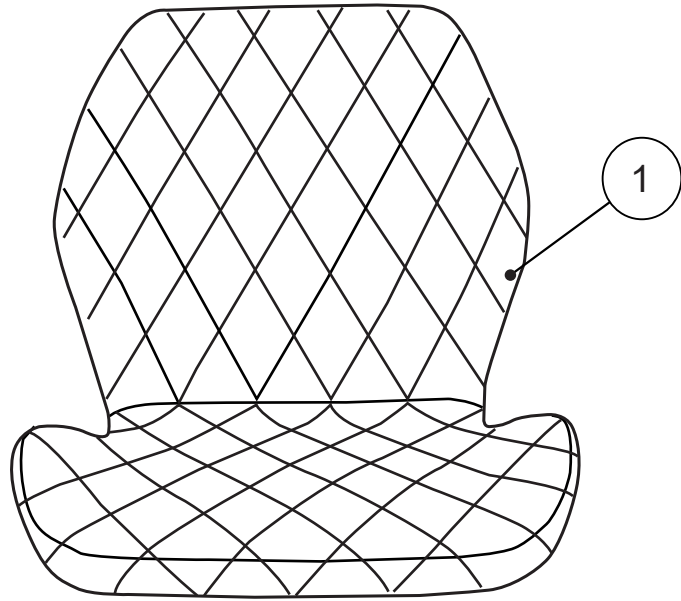

1

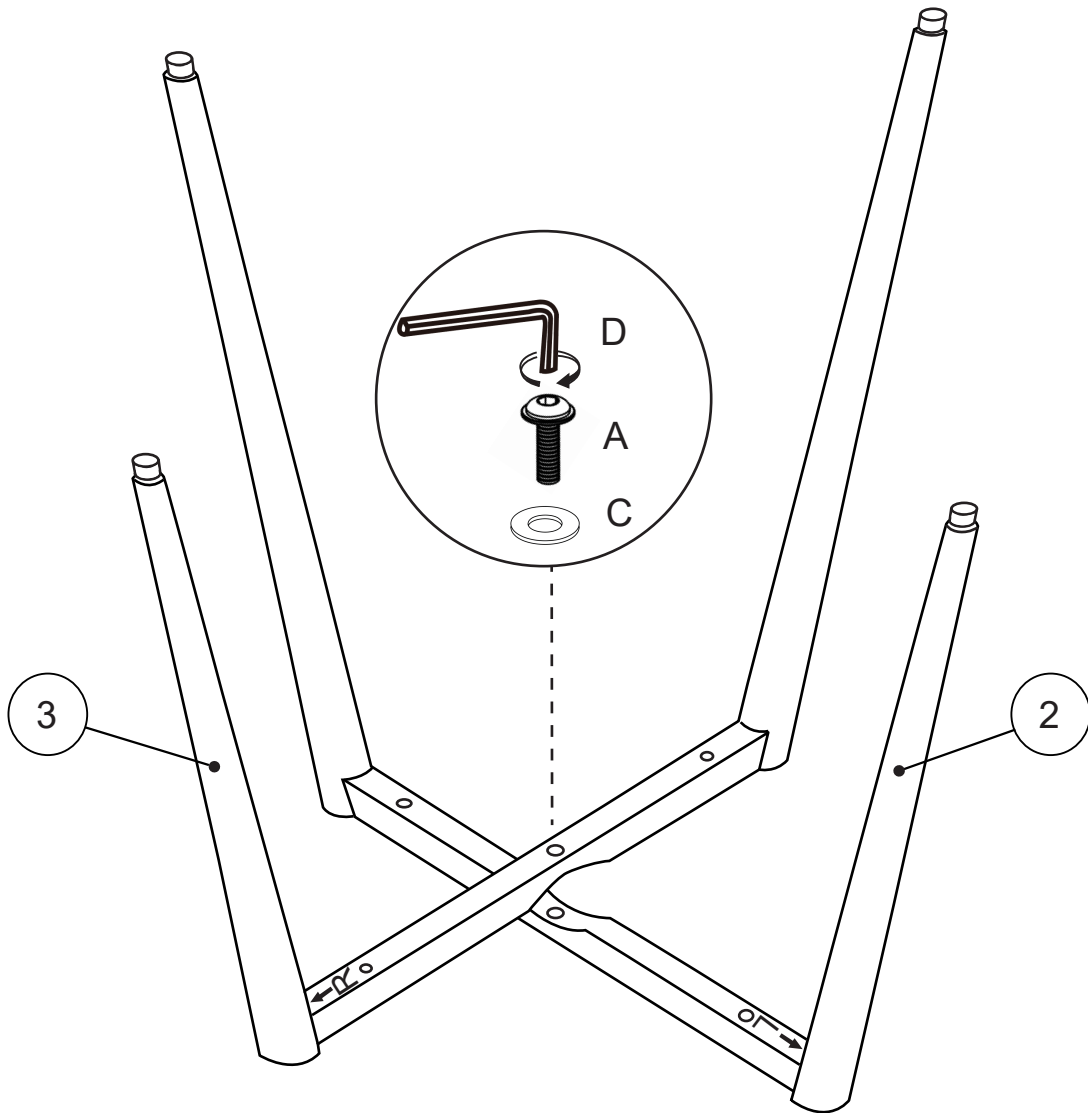
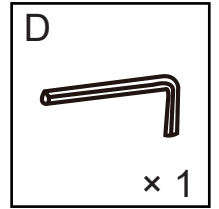
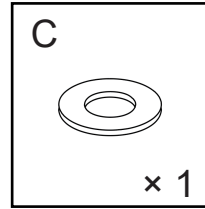
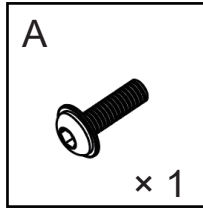

Before all parts fully assembled, be sure to keep all screws fixed to only 75%, do not over tighten in this step.

2



Before all parts fully assembled, be sure to keep all screws fixed to only 75%, do not over tighten in this step.

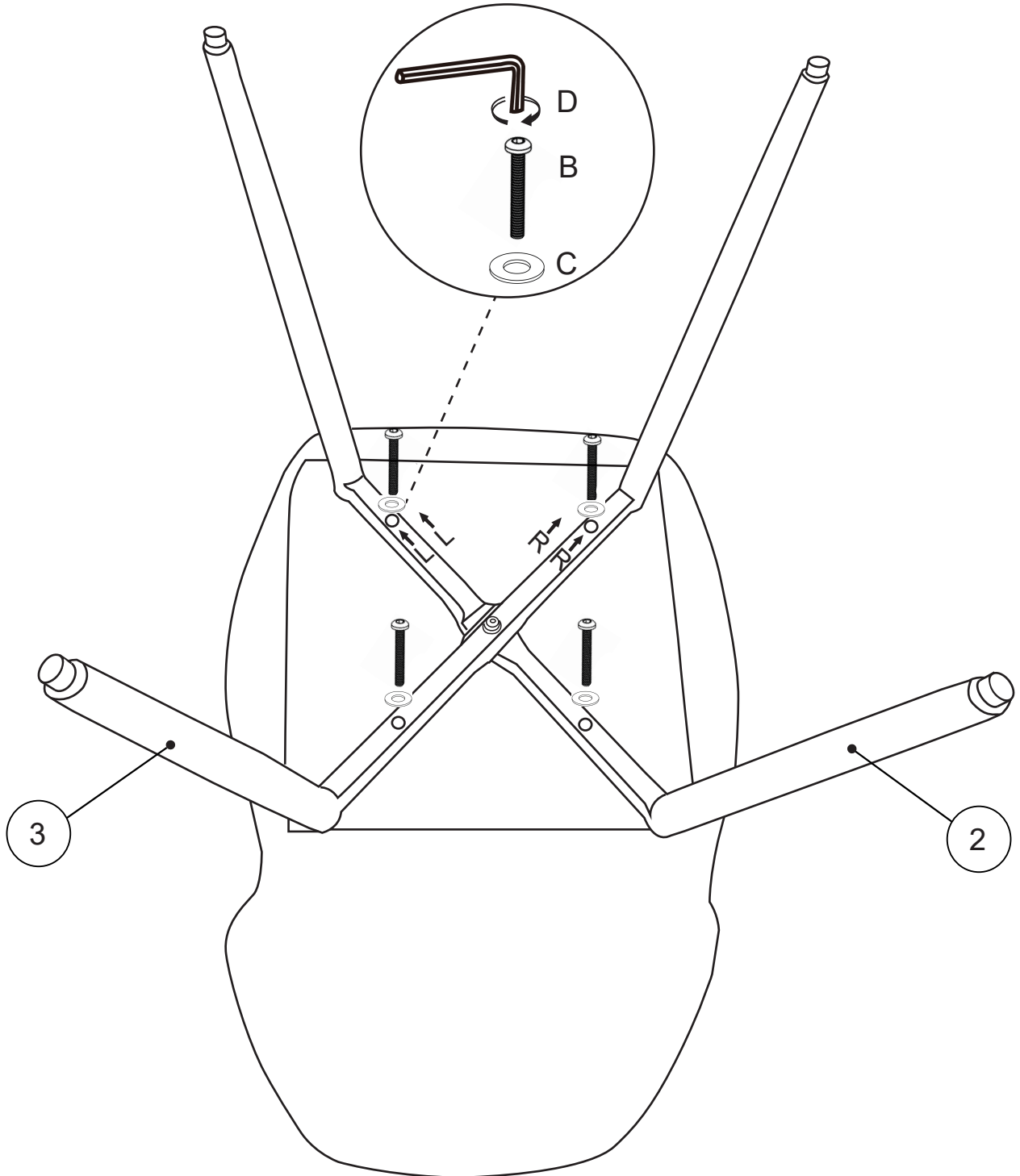
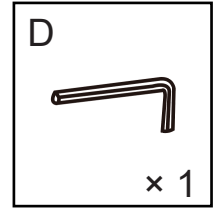
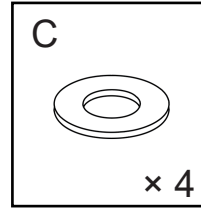
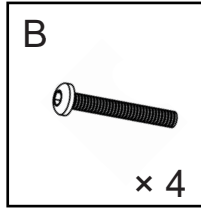

The "L" "R" marks on the leg should be in the same position as marks on seat. Wrong installation might cause the chair leg broken

3

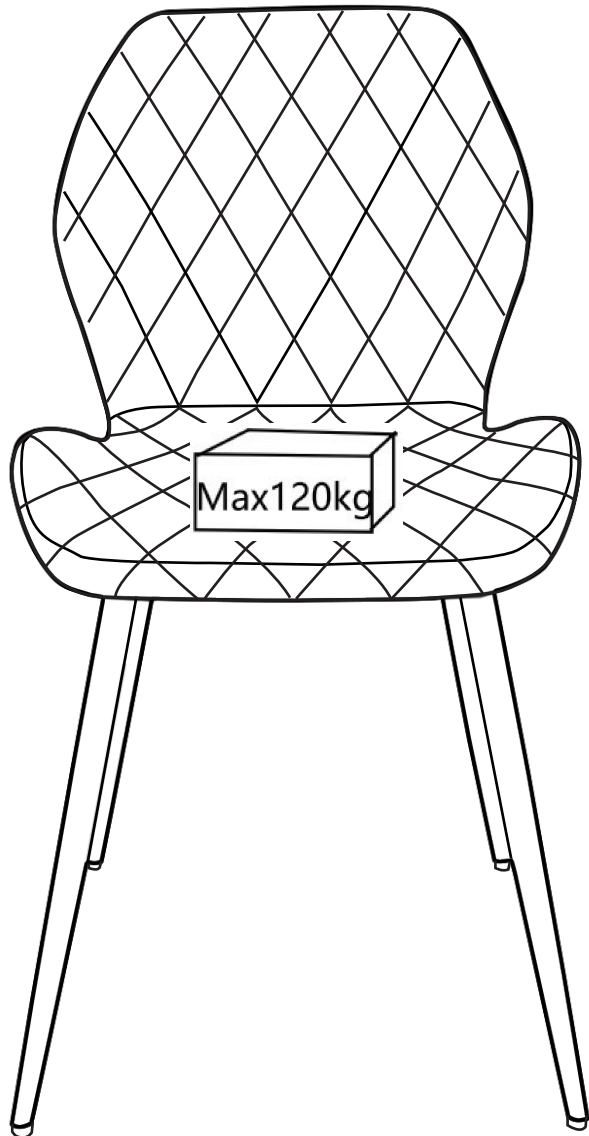

Turn it over and put it right. Adjust 4 legs land on floor, then tighten the screws slowly. During this process, please tighten screws while adjust legs balance until all the screws are tighten enough.