

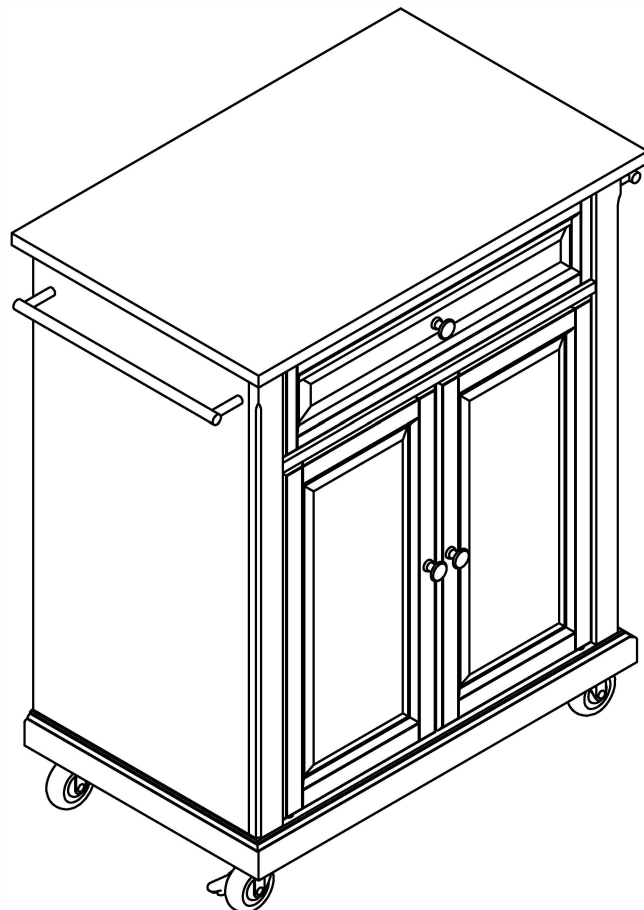

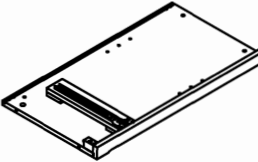

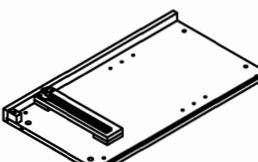

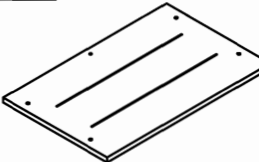
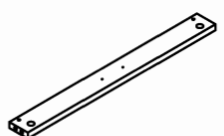
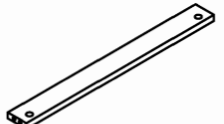
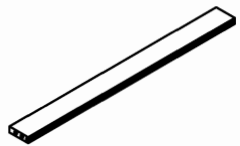

Kitchen Cart / Island

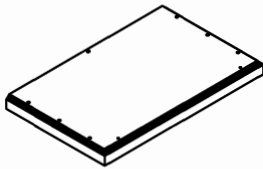
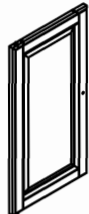
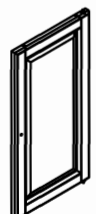
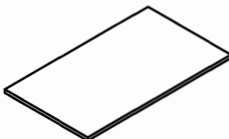
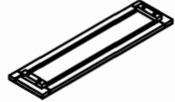
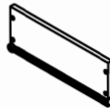
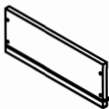
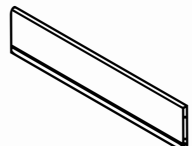
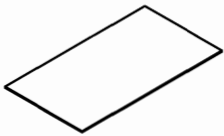

PART LIST

| | | | | |
|---|---|---|---|---|
| <p>A</p>  | <p>B</p>  | <p>C</p>  <p>(Ships Separately)</p> | <p>D</p>  | <p>E</p>  |
| <p>Left Panel 1 PC</p> | <p>Right Panel 1 PC</p> | <p>Top Panel 1 PC</p> | <p>Front Middle Rail 1 PC</p> | <p>Front Top Rail 1 PC</p> |
| <p>F</p>  | <p>G</p>  | <p>H</p>  | <p>I</p>  | <p>J</p>  |
| <p>Back Rail 2 PCS</p> | <p>Back Panel 2 PCS</p> | <p>Back Vertical Rail 1 PC</p> | <p>Bottom Panel 1 PC</p> | <p>Left Door Panel 1 PC</p> |
| <p>K</p>  | <p>L</p>  | <p>M</p>  | <p>N</p>  | <p>O</p>  |
| <p>Right Door Panel 1 PC</p> | <p>Adjustable Shelf 1 PC</p> | <p>Drawer Front Panel 1 PC</p> | <p>Drawer Left Panel 1 PC</p> | <p>Drawer Right Panel 1 PC</p> |
| <p>P</p>  | <p>Q</p>  | <p>R</p>  | <p>S</p>  | <p>T</p>  |
| <p>Drawer Back Panel 1 PC</p> | <p>Drawer Bottom Panel 1 PC</p> | <p>Locking Caster 2 PCS</p> | <p>Caster 2 PCS</p> | <p>Towel Bar 2 PCS</p> |

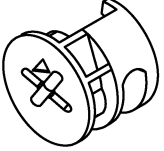
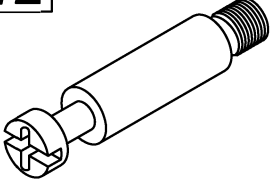
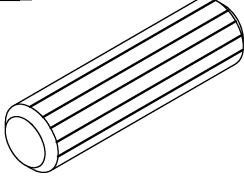
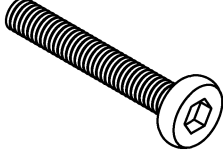
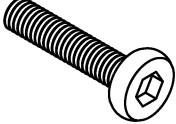
HARDWARE LIST

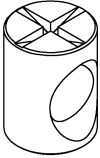
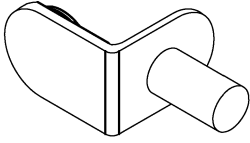
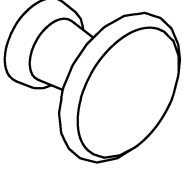
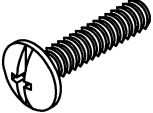
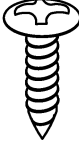
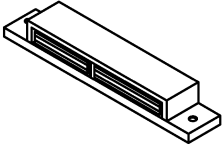
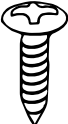
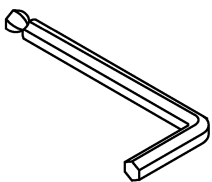
| | | | |
|--|---|---|---|
| <p>#1</p>  | <p>#2</p>  | <p>#3</p>  | <p>#4</p>  |
| <p>Cam Lock 12 PCS (Extra 2)</p> | <p>Cam Bolt 12 PCS</p> | <p>Wood Dowel 16 PCS</p> | <p>Allen Bolt 4 PCS</p> |
| <p>#5</p>  <p>1-1/4" \varnothing 1/4" D11mm</p> | <p>#6</p>  | <p>#7</p>  | <p>#8</p>  |
| <p>Short Allen Bolt 4 PCS</p> | <p>Screw 8 PCS (Extra 1)</p> | <p>Barrel Nut 4 PCS</p> | <p>Shelf Holder 4 PCS</p> |
| <p>#9</p>  | <p>#10</p>  | <p>#11</p>  <p>12mm \times \varnothing4 \times D9mm</p> | <p>#12</p>  |
| <p>Knob 3 PCS</p> | <p>Round Head Bolt 3 PCS</p> | <p>Large Round Head Screw 16 PCS (Extra 1)</p> | <p>Double Magnet 1 PC</p> |
| <p>#13</p>  | <p>#14</p>  | | |
| <p>Round Head Screw 2 PCS (Extra 1)</p> | <p>Allen Wrench 1 PC</p> | | |

ADDITIONAL TOOLS (Not Provided)

Note: It is not recommended to use power tools during assembly.

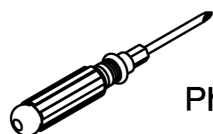

Phillips Head Screwdriver

Note: Wood dowels are intended for alignment. Additional clearance between wood dowel and pre-drilled hole is intentional for ease of assembly.

Step 1. Insert cam bolts (part #2) into left panel (part A), right panel (part B) and top panel (part C) using phillips head screwdriver.

NOTE: Do not overtighten cam bolts. Stop tightening once threads on cam bolt are no longer visible.

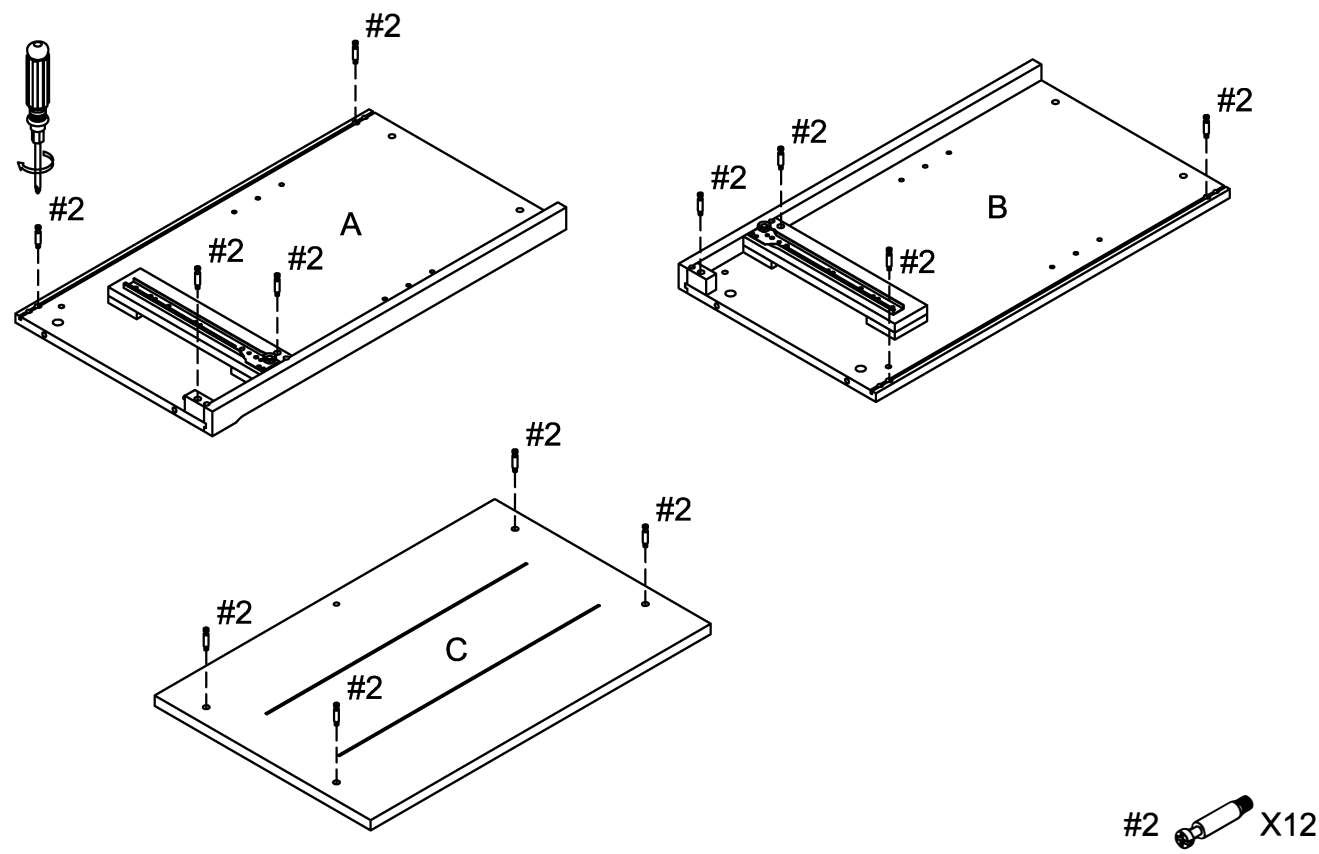

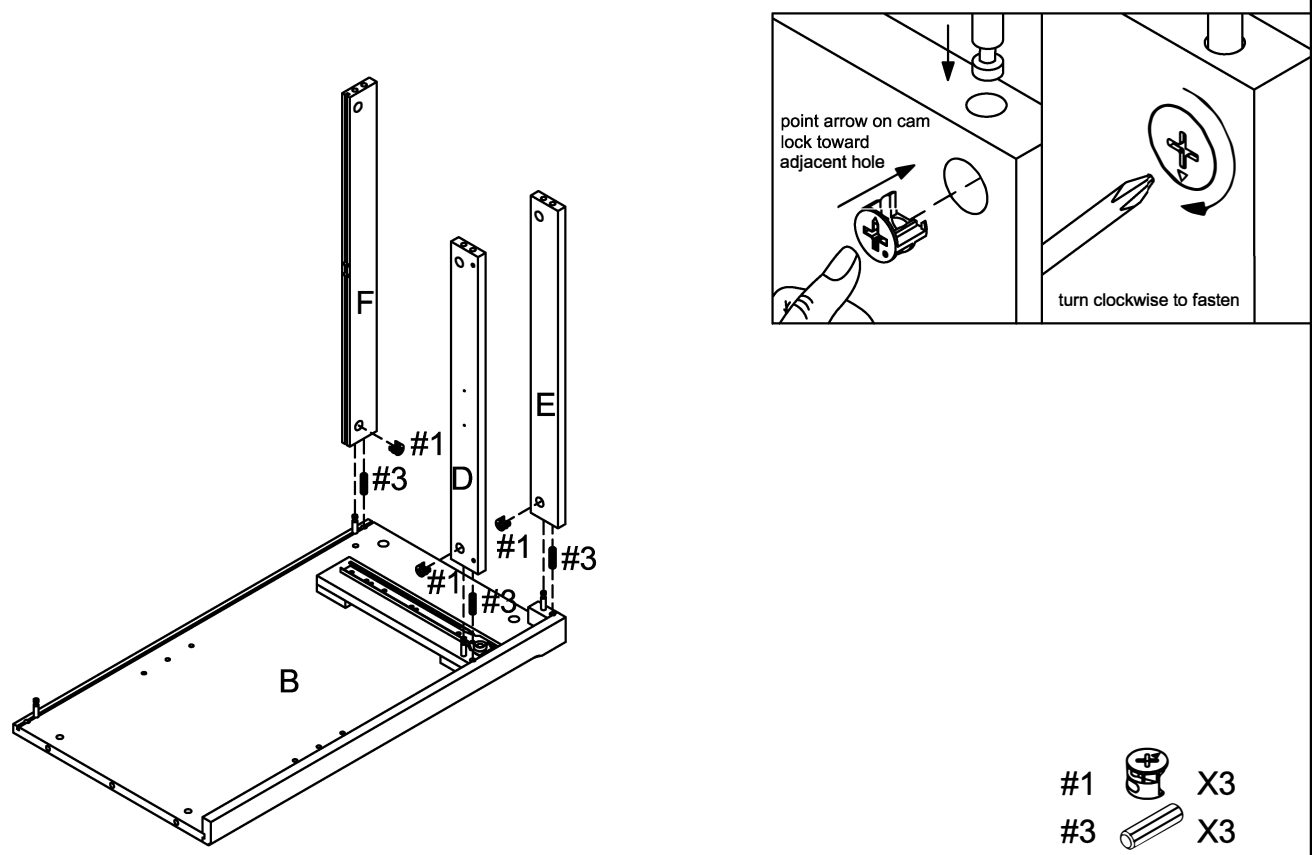

Step 2. Attach rails (parts D, E & F) to right panel (part B) using cam locks (part #1) and wood dowels (part #3).

NOTE: Cam locks must rotate a full 180°. See pictured insert.

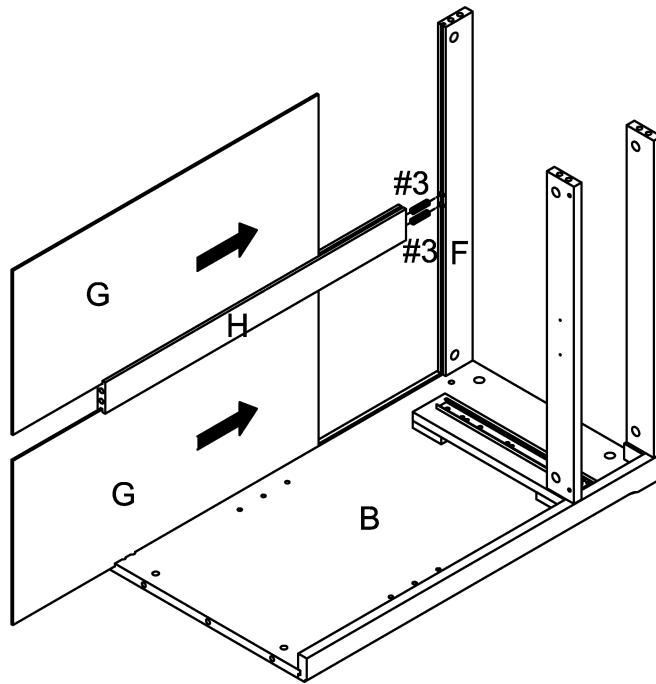

Step 3. Attach back vertical rail (part H) to back rail (part F) using wood dowels (part #3). Slide back panels (part G) into grooves of assembled unit (parts B, F & H).





#3  X2

Step 4. Attach back rail (part F) to assembled unit (parts B, G & H) using cam lock (part #1) and wood dowels (part #3).

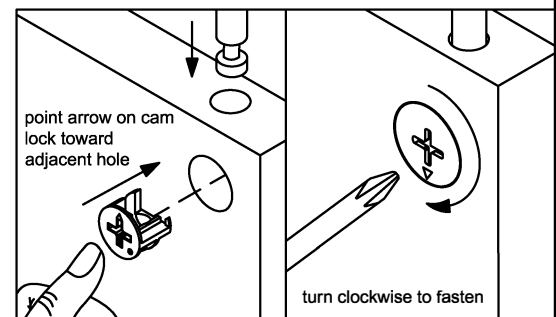
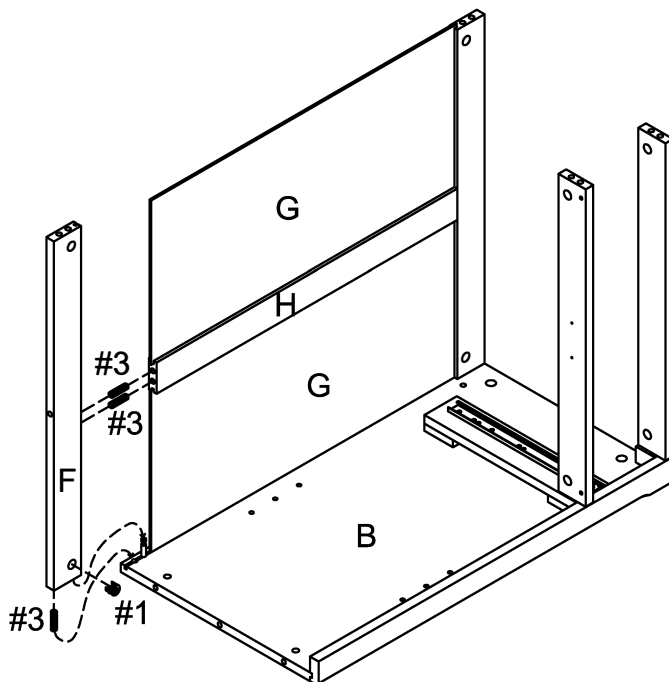
NOTE: Cam locks must rotate a full 180°. See pictured insert.





#1  X1
#3  X3

Step 5. Attach left panel (part A) to assembled unit (parts D, E, F & G) using cam locks (part #1) and wood dowels (part #3).

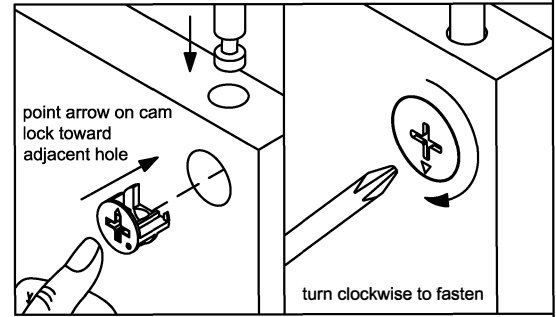
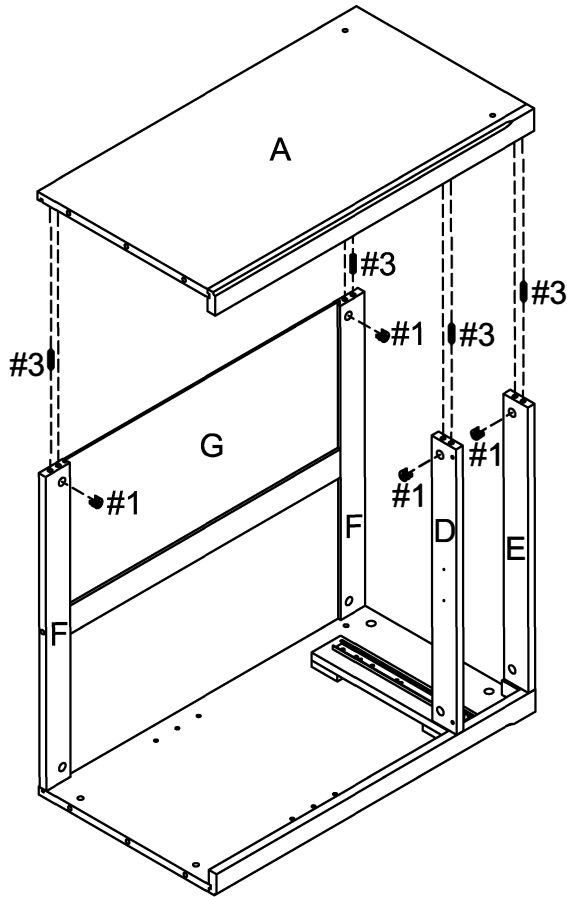





NOTE: Cam locks must rotate a full 180°. See pictured insert.

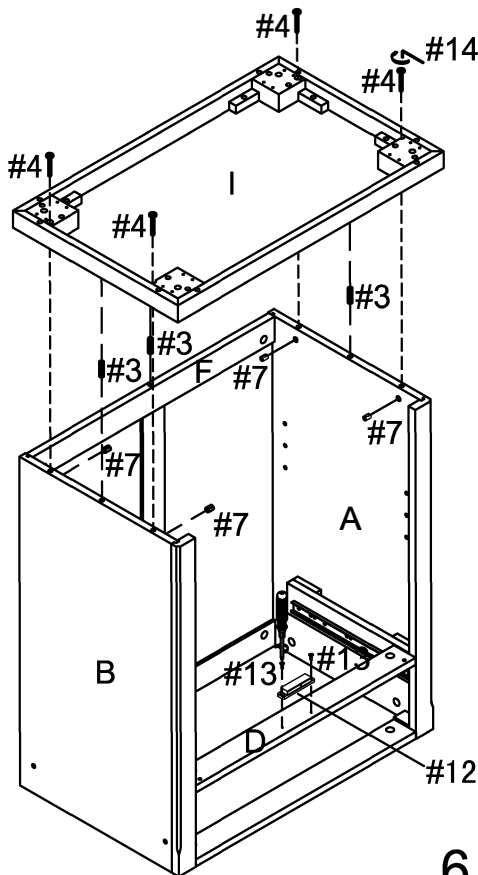

- #1  X4
- #3  X4

Step 6. Carefully turn unit upside down on a soft flat surface, such as carpet, as shown below. Attach bottom panel (part I) to assembled unit (parts A, B & F) using wood dowels (part #3), allen bolts (part #4), barrel nuts (part #7) and allen wrench (part #14). Attach double magnet (part #12) using round head screws (part #13) and phillips head screwdriver.



- #3  X3
- #4  X4
- #7  X4
- #12  X1
- #13  X2
- #14  X1

Step 7. CASTER INSTALLATION

Attach locking casters (part R) and casters (part S) to bottom panel (part I) using large round head screws (part #11) and phillips head screwdriver.

LEG INSTALLATION

Do not install casters. Attach legs using instruction manual and hardware included inside leg packaging.

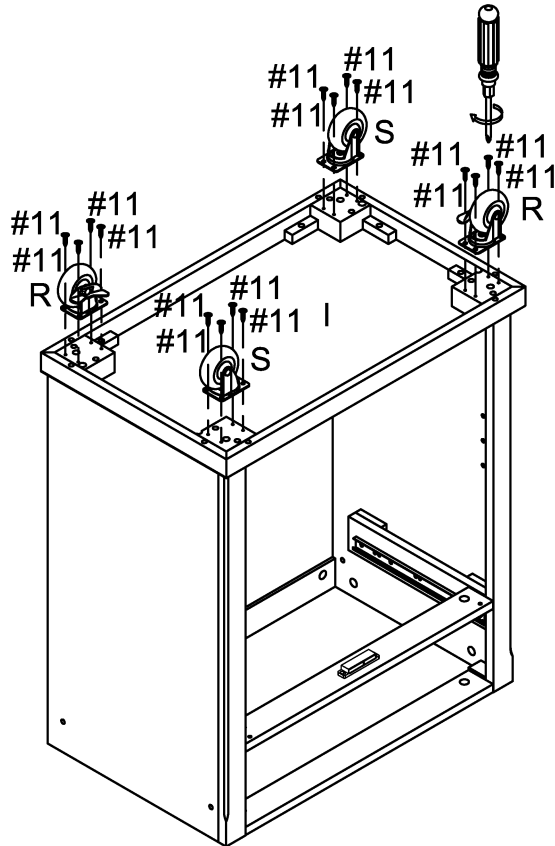

#11  X16

Step 8. Carefully turn unit upright. Attach towel bars (part T) to panels (parts A & B) using short allen bolts (part #5) and allen wrench (part #14).

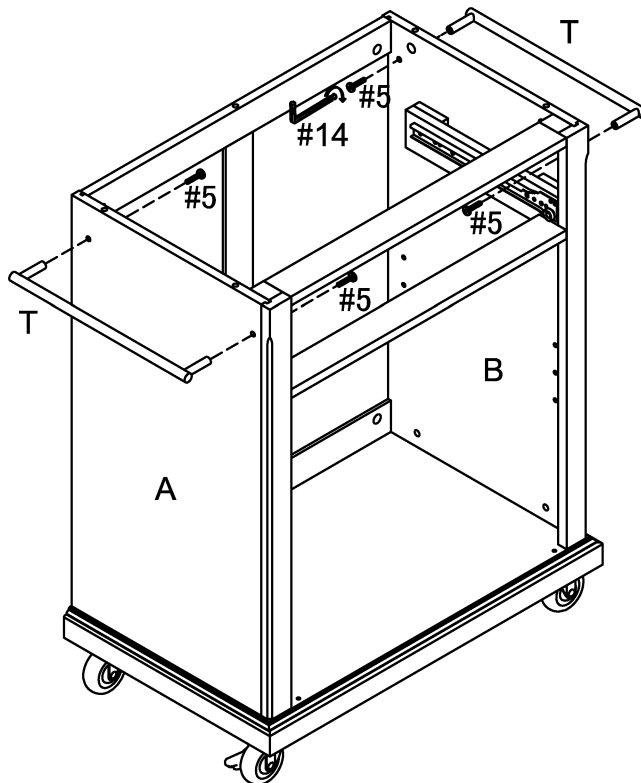

#5  X4
#14  X1

Step 9. Attach top panel (part C) to assembled unit (parts A, B & F) using cam locks (part #1) and wood dowel (part #3).

NOTE: Cam locks must rotate a full 180°. See pictured insert.

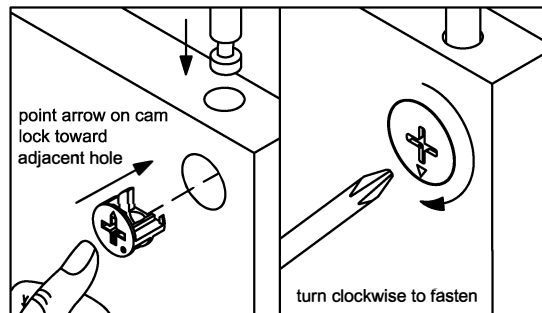
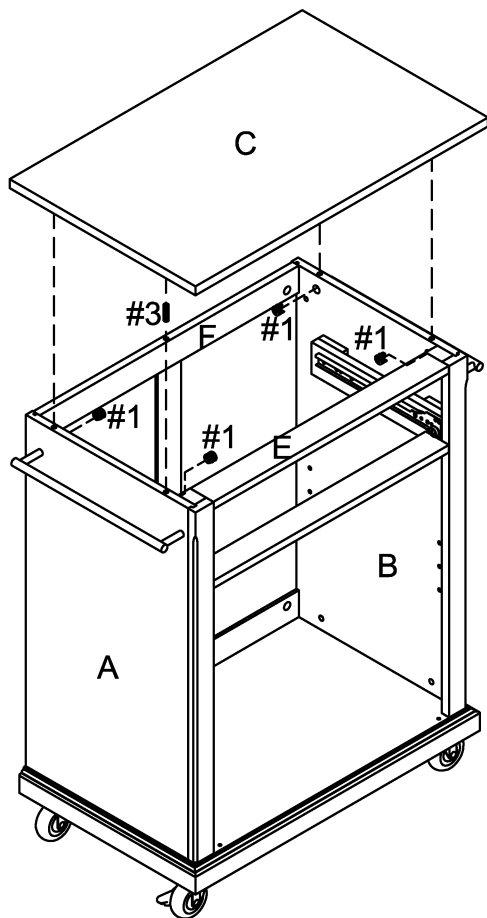

- #1  X4
- #3  X1

Step 10. Attach knobs (part #9) to door panels (parts J & K) using round head bolts (part #10) and phillips head screwdriver. Attach door panels (parts J & K) by placing bottom pin hinge (pre-installed in door) in the pre-drilled hole of bottom panel (part I). Then depress the top spring-loaded pin hinge so it can be placed in the pre-drilled hole of front middle rail (part D). Place shelf holders (part #8) into desired position.

NOTE: Be sure top and bottom pin hinges are fully extended to secure doors in place.

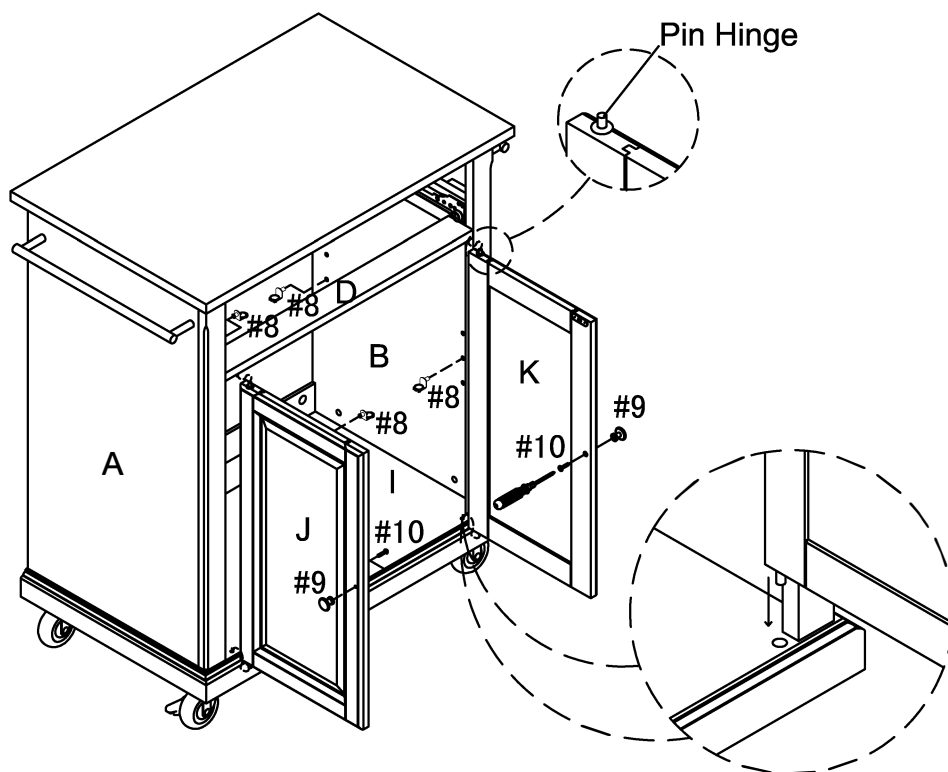

- #8  x4
- #9  x2
- #10  x2

Step 11. Attach knob (part #9) to drawer front panel (part M) using round head bolt (part #10) and phillips head screwdriver. Attach drawer panels (parts N & O) to drawer front panel (part M) using screws (part #6) and phillips head screwdriver. Slide drawer bottom panel (part Q) into grooves of assembled unit (parts M, N & O). Attach drawer back panel (part P) to assembled unit (parts N, O & Q) using screws (part #6) and phillips head screwdriver.

NOTE: Be sure drawer glide wheels are facing back panel.

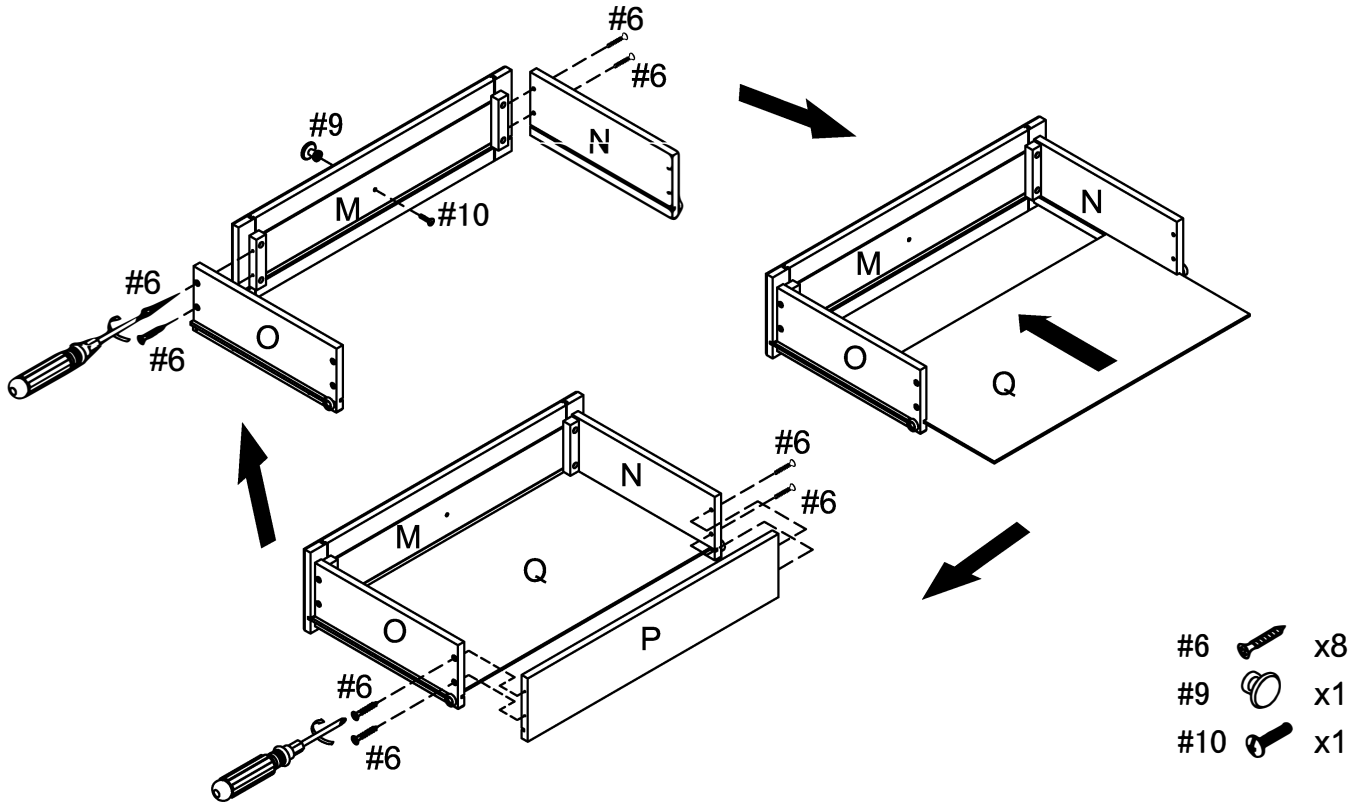

Step 12. Slide assembled drawer into place. Slide adjustable shelf (part L) into place.

