



INSTRUCTION MANUAL
BUILT-IN WINE COOLER
MODEL: BDW5034D-2



BEFORE USE, PLEASE READ AND FOLLOW ALL SAFETY RULES AND OPERATING INSTRUCTIONS.

Allavino has a policy of continuous improvement on its products and reserves the right to change materials and specifications without notice

ALLAVINO

8520 Miralani Dr., San Diego, CA 92126

Table of Contents

Diagram	3
Safety Tips	4
Handle Installation	5
Installation Instructions	5-6
Operation Instructions	7
Setting Temperature	7
Shelving	8
Care and Maintenance	9
Troubleshooting	10
Technical Specifications	11
Specifications for Built-In Installation	12
Warranty Information	13

DIAGRAM

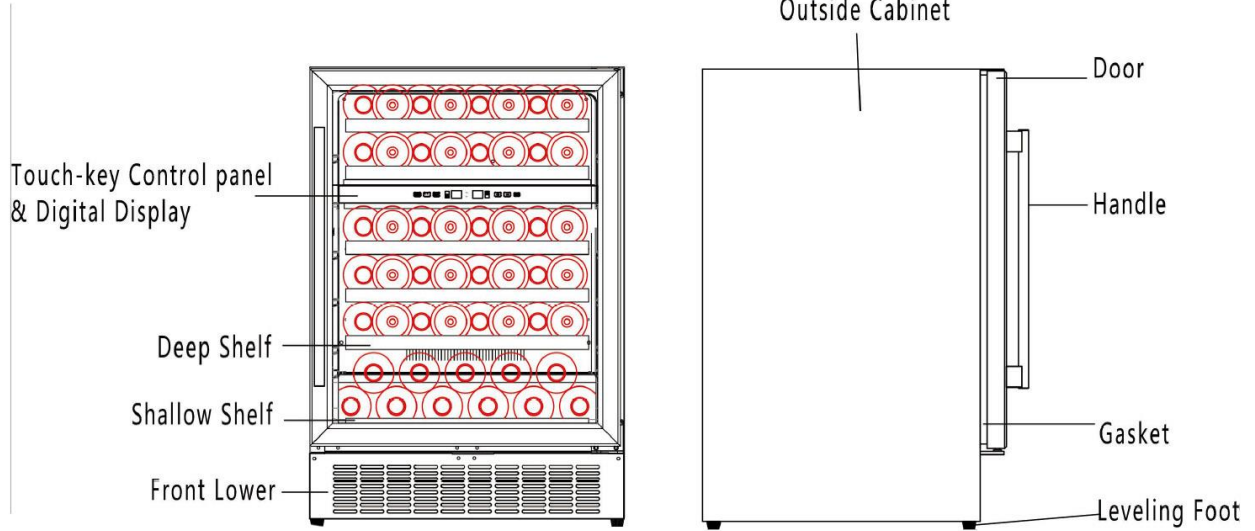

WARNING

- To prevent damaging the door gasket, make sure to have the door all the way opened when pulling shelves out of the rail compartment.
- The appliance must be positioned so that the plug is accessible. Release the electric cord. Move your cabinet to its final location. Do not move your Cabinet while loaded with wine. You might distort its body. The wine cellar should be installed in a suitable place in order to avoid touching the compressor with hand.
- This appliance is not intended for use by persons (including children) with reduced physical, sensory or mental capabilities or lack of experience and knowledge, unless they have been given supervision or instruction concerning use of the appliance by a person responsible for their safety.
- If the supply cord is damaged, it must be replaced by manufacturer of its Service agent or a similarly qualified person in order to avoid a hazard.

PLEASE DON'T TRY TO PLUG INTO OR EXTENSION THE CABLE IN ANY CASE.

Wine cooler self-checking:

- The unit will have “bee”, “bee” after power on, this means the wine cooler is self-checking before operation.

IMPORTANT SAFETY INSTRUCTIONS

- Read all instructions before using the Wine cellar.
- **DANGER or WARNING:** Risk of child entrapment.
- Child entrapment and suffocation are not problems of the past. Junked or abandoned appliances are still dangerous even if they will “just sit in the garage a few days”.
- **Before you throw away your old Wine Cellar:** Take off the door. Leave the shelves in place so that children may not easily climb inside.
- Never allow children to operate, play with, or crawl inside the appliance.
- Never clean appliance parts with flammable fluids. The fumes can create a fire hazard or explosion.
- Do not store or use gasoline or any other flammable vapors and liquids in the vicinity of this or any other appliance. The fumes can create a fire hazard or explosion. Do not store explosive substances such as aerosol cans with a flammable propellant in this appliance.
- **WARNING:** Keep ventilation openings, in the appliance enclosure or in the built-in structure, clear of obstruction;
- **WARNING:** Do not use mechanical devices or other means to accelerate the defrosting process, other than those Recommended by the manufacturer;
- To avoid a hazard due to instability of the appliance, it must be fixed in accordance with the instructions.
- **WARNING:** Do not damage the refrigerant circuit;
- **WARNING:** Do not use electrical appliances inside the food storage compartments of the appliance, unless they are the type recommended by the manufacturer.
- **If the refrigerant of these appliances are R600a, Flammable and explosive articles should not be put in or near the cabinet, to avoid the fire or explode caused.**

UNPACKING AND INSTALLING THE DOOR HANDLE

Remove the exterior and interior packing materials.

Install the door handle provided with the appliance by following these steps:

Step 1 — Remove the gasket at the inner side of the door to expose the two screw holes.

Step 2 — Install the handle tightly with the screws and washers provided.

Step 3 — Tidy and restore the gasket.

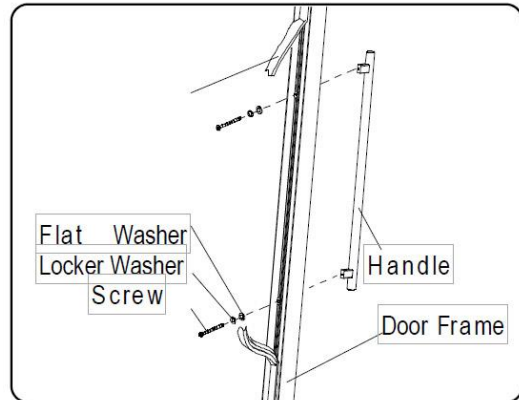

INSTALLATION INSTRUCTIONS

Before Using Your Wine cellar

- Remove the exterior and interior packing.
- Before connecting the Wine cellar to the power source, let it stand upright for approximately 24 hours. This will reduce the possibility of a malfunction in the cooling system from handling during transportation.
- Use a soft cloth to clean the interior surface with lukewarm water.
- This appliance is intended to be used in household and similar applications such as
 - Staff kitchen areas in shops, offices, and other working environments
 - Farm houses and by clients in hotels, motels and other residential type environments
 - Bed and breakfast type environments
 - Catering and similar non-retail applications
- When disposing your appliance, please choose an authorized disposal site.

Installation of Your Wine Cellar

- This appliance is designed to be for free standing installation or built-in (fully recessed) (Refer to sticker location the back of this appliance).
- This appliance is intended to be used exclusively for the storage of wine or beverages.
- Place your Wine cellar on a flat floor that is strong enough to support it when it is fully loaded. To level your Wine cellar, adjust the front leveling leg at the bottom of the Wine cellar.
- This appliance is using flammability refrigerant. So never damage the cooling pipework during the transportation. Locate the Wine cellar away from direct sunlight and sources of heat (stove, heater, radiator, etc.). Direct sunlight may affect the acrylic coating and heat sources may increase electrical consumption. Extreme cold ambient temperatures may also cause the unit not to perform properly.
- Avoid locating the unit in moist areas.
- Plug the Wine cellar into an exclusive, properly installed-grounded wall outlet. Do not cut or remove the third (ground) prong from the power cord under any circumstances. Any questions

concerning power and/or grounding should be directed toward a certified electrician or an authorized Products service center.

Attention

- Store wine in sealed bottles
- Do not overload the cabinet
- Do not open the door unless necessary
- Do not cover shelves with aluminum foil or any other shelf material which may prevent air circulation
- Should the Wine cellar be stored without use for long periods, it is suggested to leave the door ajar to allow air to circulate inside the cabinet after a careful cleaning, avoiding possible formations of condensation, mold or odors.

Ambient Room Temperature Limits

This appliance is designed to operate in ambient temperatures specified by its temperature class marked on the rating plate.

Class	Symbol	Ambient Temperatures range (°C / °F)
Extended Temperate	SN	+ 10°C / 50 °F to + 32°C / 89.6°F
Temperate	N	+ 16°C / 60.8°F to + 32°C / 89.6°F
Subtropical	ST	+ 16°C / 60.8°F to + 38°C / 100.4°F
Tropical	T	+ 16°C / 60.8°F to + 43°C / 109.4°F

Wine Storage

- To prevent damaging the door gasket, make sure to have the door opened fully all the way before pulling the shelves out.
- Please store wine in sealed bottles.
- Should the wine cooler be left empty for long periods it is suggested that the appliance is unplugged, and after careful cleaning, leave the door ajar to allow air to circulate inside the cabinet in order to avoid possible condensation, mold or become odor forming.
- Recommended Temperatures for chilling/storage your wines:

Red Wines	15-18°C / 59-64.4°F
Dry/White Wines	9-14°C / 48.2-57.2°F
Rose Wines	10-11°C / 50-51.8°F
Sparkling Wines	5-8°C / 41-46.4°F

OPERATING YOUR WINE CELLAR & SETTING TEMPERATURE CONTROL

Control System Instruction



- Press LOCK for 3 seconds to unlock/lock all the buttons. If there is no operation within 15 seconds after unlock, the buttons will be locked automatically.
- Press left PLUS or MINUS to adjust the temperature of upper zone.
- Press right PLUS or MINUS to adjust the temperature of lower zone.
- Press left PLUS and MINUS at the same time for 3 seconds to power on/off.
- Press right PLUS and MINUS at the same time for 3 seconds to switch between Celsius and Fahrenheit.
- Press LIGHT to turn on or off the lights.

Setting the Temperature Controls

- When press the temperature setting button, the system will enter the set up mode of the upper or lower compartment automatically. The display will flash and show the setting temperature. After 5 seconds the flash will stop and it will show the actual measured interior temperature.
- Press the button "+" or "-" once, the temperature will decrease or increase 1 °C/1°F; After stopping pressing the button for 5 seconds, LCD figure will stop flash, then revert back to display the setting temperature of the upper or lower compartment.
- After the unit is unplugged, the system will return to default setting temperature, which set by factory.

Attention

If the unit is unplugged, power lost, or turned off, you must wait 3 to 5 minutes before restart the unit. If you attempt to restart before this time delay, the Wine Cellar will not start. If first time use or longer absence of using, the temperature will be different between setting and LED display temperature. After running a period, the temperature will be reverting back.

SHELVING

- To prevent damaging the door gasket, make sure to have the door all the way opened when pulling shelves out of the rail compartment.
- For easy access to the storage content, you must pull the shelves approximately 1/3 out of the rail compartment, however this unit was designed with a notch on each sides of the shelf tracks to prevent bottles from falling.
- If you need to take out any shelf, use one hand to press down the right plastic notch as shown in Figure A and at the same time lift the left plastic notch by other hand as shown in Figure B. Hold both notches and then proceed to pull out the shelf slowly. Contact our service department if assistance is needed.

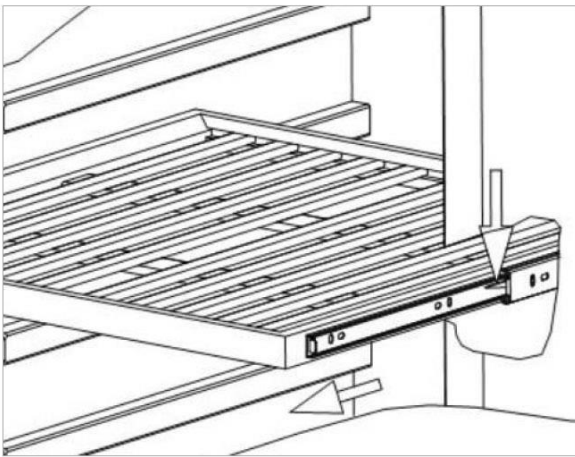

Figure A

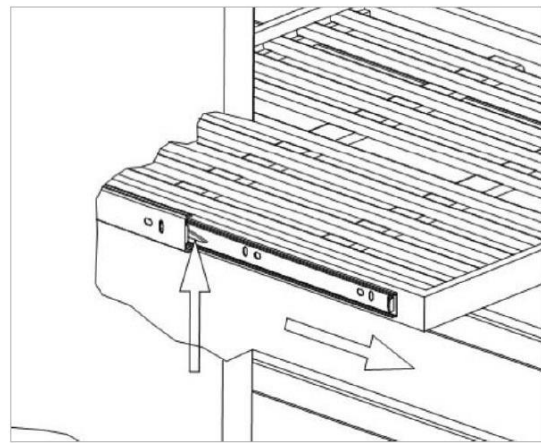

Figure B

CARE & MAINTENANCE

Cleaning Your Wine Cellar

- Turn off the power, unplug the appliance, and remove all items including shelves and rack.
- Wash the inside surfaces with warm water and mild solution.
- Wash the shelves with a mild detergent solution.
- Wring excess water out of the sponge or cloth when cleaning area of the controls, or any electrical parts.
- Wash the outside cabinet with warm water and mild liquid detergent. Rinse well and wipe dry with a clean soft cloth.

Power Failure

Most power failures are corrected within a few hours and should not affect the temperature of your appliance if you minimize the number of times the door is opened. If the power is going to be off for a long period of time, you need to take the proper steps to protect your contents.

Vacation Time

- Short vacations: Leave the Wine Cellar operating during vacations of less than three weeks.
- If the appliance will not be used for several months, remove all items and turn off the appliance. Clean and dry the interior thoroughly. To prevent odor and mold growth, leave the door open slightly: blocking it open if necessary.

Moving Your Wine Cellar

- Remove all items.
- Take out the loose items inside the wine cellar (such as shelf), or fix the loose items with the foam.
- Turn the adjustable leg up to the base to avoid damage.
- Tape the door shut.
- Be sure the appliance stays secure in the upright position during transportation. Also protect outside of appliance with a blanket or similar items.

Energy Saving Tips

The Wine Cellar should be located in the coolest area of the room, away from producing appliances, and out of the direct sunlight.

TROUBLESHOOTING

There are many common issues you may experience with your wine cellar that can be solved very easily, without the need of a service call. Try the tips below to troubleshoot your unit should you experience any problems:

PROBLEM	POSSIBLE CAUSE
Wine Cellar does not operate	Not plugged in. The appliance is turned off. The circuit breaker tripped or a blown fuse.
Wine Cellar is not cold enough	Check the temperature control setting. External environment may require a higher setting. The door is opened too often. The door is not closed completely. The door gasket does not seal properly.
Turns on and off frequently	The room temperature is hotter than normal. Overload of the cabinet. The door is opened too often. The door is not closed completely. The temperature control is not set correctly. The door gasket does not seal properly.
The light does not work	Not plugged in. The circuit breaker tripped or a blown fuse. The bulb has burned out. The light button is "OFF".
Vibrations	Check to make sure that the Wine Cellar is level.
Too much noise	The rattling noise may come from the flow of the refrigerant, which is normal. As each cycle ends, you may hear gurgling. Contraction and expansion of the inside walls may cause popping and crackling noises. The Wine Cellar is not level.
The door will not close properly	The Wine Cellar is not level. The door was reversed and not properly installed. The gasket is dirty. The shelves are out of position.
The control panel does not work	Not plugged in. The control panel is locked. Please press the lock button for 3 seconds to unlock.
The unit beeps	Wine cooler self-checking. This is normal.

Before disposal of the appliance:

1. Disconnect the main plug from the main socket.
2. Cut off the main cable and discard it.

TECHNICAL SPECIFICATIONS

Bottle Capacity	Up to 50 Bottles
Dimensions	34.2" H x 23.8" W x 23.5" D (25.25" w/handle)
Weight	129 lbs.
Voltage / Frequency	115V / 60 Hz
Running Amps	1.1 A
Operating Temperature	Upper Zone: 41 °F – 54 °F Lower Zone: 54 °F – 68 °F
Maximum Ambient Temperature	109.4 °F

SPECIFICATIONS FOR BUILT-IN INSTALLATION

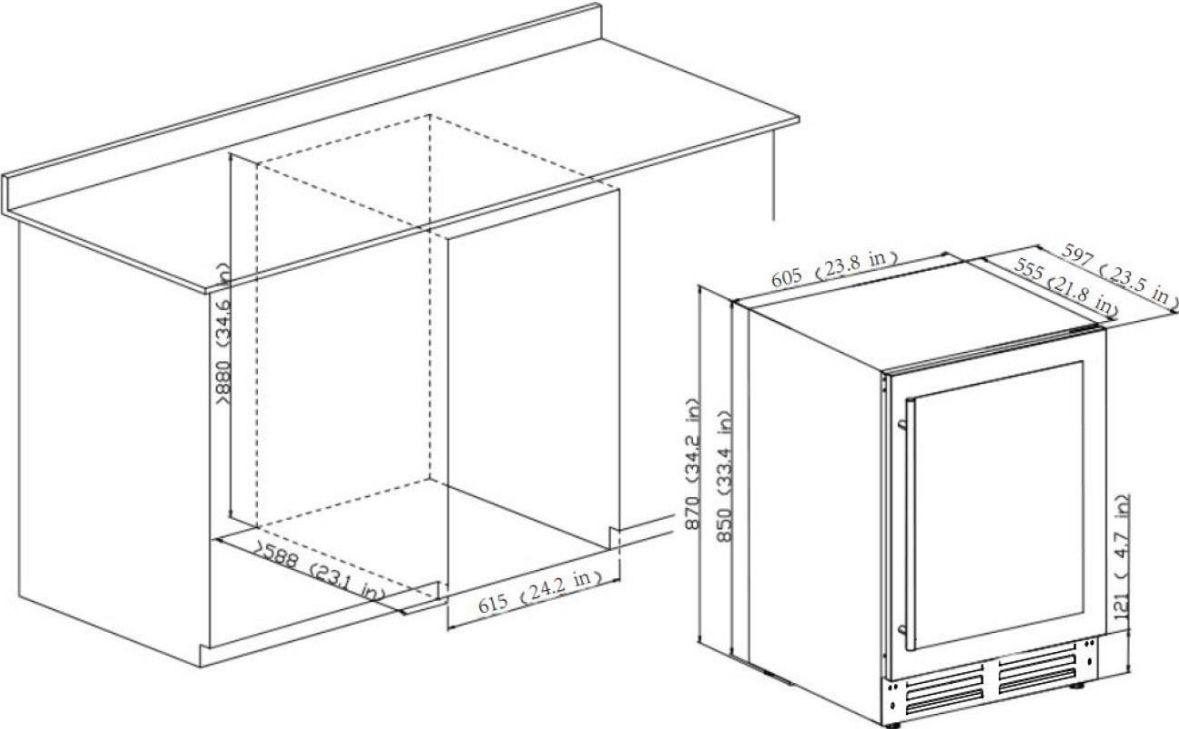

WARRANTY INFORMATION

WHAT IS COVERED LIMITED ONE-YEAR WARRANTY:

For one year from the date of purchase by the original owner, Allavino will, at its option, repair or replace any part of the unit, which proves to be defective in material or workmanship under normal use. During this period Allavino will provide all parts and labor necessary to correct such defects free of charge, so long as the unit has been installed and operated in accordance with the written instructions in this manual. Allavino will provide you with a reasonably similar replacement product that is either new or factory refurbished. In rental or commercial use, the warranty period is 90 days. All Allavino Appliances of 3.5 cubic feet capacity or less must be brought/sent to the appliance service shop for repair.

LIMITED SECOND THROUGH FIFTH YEAR WARRANTY:

For the second through the fifth year from date of original purchase, Allavino Products will provide a replacement compressor free of charge due to a failure. You are responsible for the service labor and freight charges. In rental or commercial use, the limited compressor warranty is one year and nine months. Cost to move the appliance to the servicers' shop and back to the user's home, as may be required, are the user's responsibility.

WHAT IS NOT COVERED:

- Content losses of food or other, due to spoilage.
- Incidental or consequential damages.
- Parts and labor costs for the following will not be considered as warranty:
 - Door springs, and/or frames.
 - Inner door panels, door rails and/or door supports.
 - Light bulbs and/or plastic housing.
 - Plastic cabinet liners.
 - Punctured evaporator that voids the warranty on the complete sealed system.
 - Repairs performed by unauthorized servicers.
 - Shipping and handling costs associated with the replacement of the unit.
 - Service calls that do not involve defects in material or workmanship such as customer education, door reversal, or proper installation.
 - Surcharges including, but not limited to, any after hour, weekend, or holiday service calls, tolls, ferry trip charges, or mileage expense for service call to remote areas, including the State of Alaska.
 - Service calls that are related to external problems, such as abuse, misuse, inadequate electrical power, accidents, fire, floods, or acts of God.
 - Replacement of house fuses or resetting circuit breakers.
- Failure of the product if it is used for other than its intended purpose.
- This warranty does not apply outside the Continental USA.

SERVICE FOR YOUR WINE CHILLER:

With the purchase of your Allavino appliance, you can have the confidence that if you ever need additional information or assistance, the Allavino Customer Service team will be here for you. Whatever your questions are about our products, help is available. Just call us toll-free.

ALLAVINO PRODUCT CUSTOMER SERVICES:

Product Information, Part Orders and In-Home Repair Service: **888-980-4809**