







TWO-SHELF RECTANGLE COFFEE TABLE

Metal • Glass

Examine all packaging material for small parts that may have come loose during shipment. Periodic checks are recommended to insure that all components are in proper position, tight and free from damage. Keep this assembly instruction for future reference. Adult assembly is required.

HARDWARE LIST

- A (8) 1/4" x 15mm Allen Bolts
- B (8) Spring Washers
- C (8) Flat Washers
- D (8) 1/4" x 15mm Sunk Bolts
- E (1) Allen Wrench
- F (12) Glass Pads

PART	QTY	HARDWARE	PART	QTY	HARDWARE
A	8		B	8	
C	8		D	8	
E	1		F	12	

PARTS LIST

- G (1) Table Top Frame
- H (1) Top Glass Shelf
- I (1) Bottom Glass Shelf
- J (1) Support Brace
- K (2) Left Legs
- L (2) Right Legs

STEP 1 - Figure 1

Begin assembly by attaching Legs (K and L) to Table Top Frame (G) using 2 Sunk Bolts (D) per leg. Do not tighten bolts at this time.

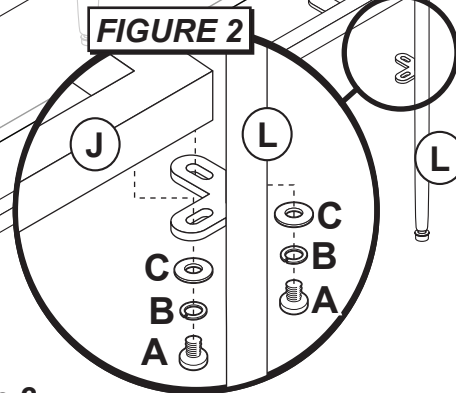
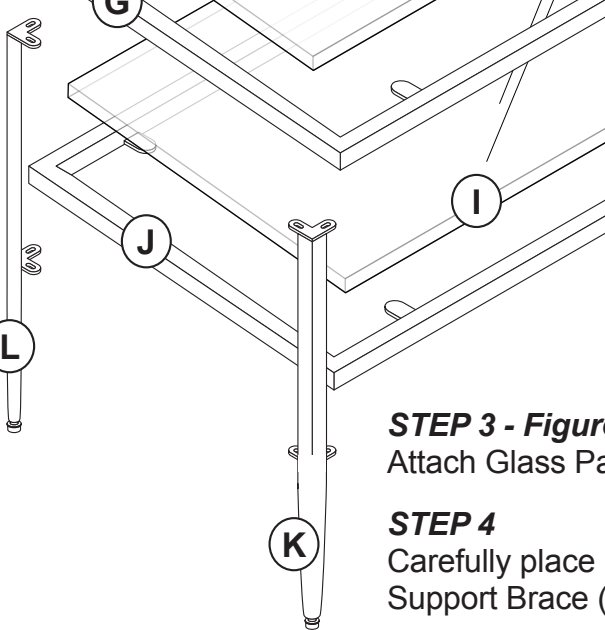
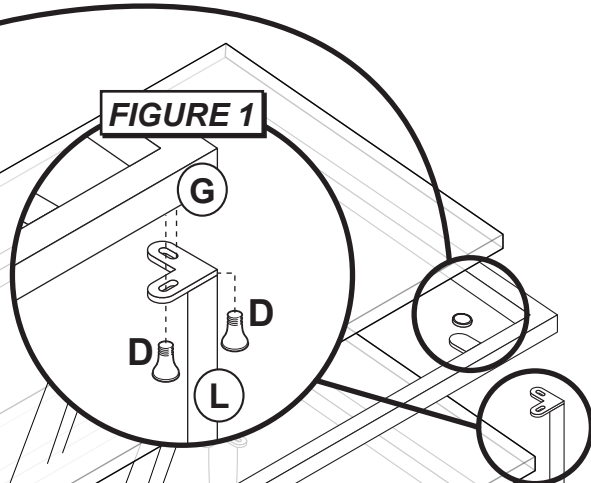
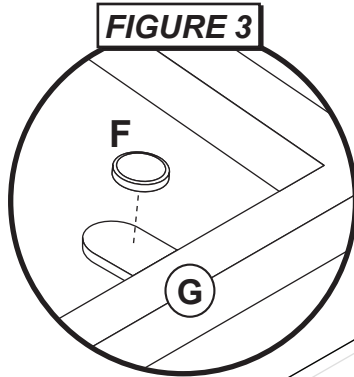

STEP 2 - Figure 2

Attach Support Brace (J) to Legs (K and L) using 2 Bolts (A), 2 Spring Washers (B) and 2 Flat Washers (C) per leg. Tighten all bolts from steps 1 & 2 with Allen Wrench (E) provided.

STEP 3 - Figure 3

Attach Glass Pads (F) to tabs on Table Top Frame (G) and Support Brace (J).

STEP 4

Carefully place Glass Shelves (H and I) down into Table Top Frame (G) and Support Brace (J) respectively. The assembly is now complete.

CARE & MAINTENANCE: The touch of a soft cloth is all the maintenance the finish will ever need. Please do not use harsh or abrasive cleaners for polishing, as they may cause damage to the finish. Periodic checks are recommended to make sure that all hardware is securely tightened.