

ASSEMBLY INSTRUCTION

SIDE CHAIR

PART LIST:

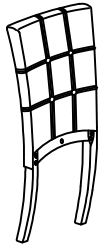

Back 1pc

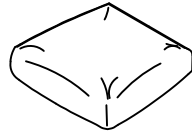

Seat 1pc

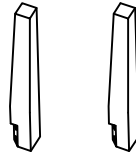

Front leg
2pcs

HARDWARE LIST				
A		Allen Wrench	12mm	1 PC
B		Bolt	Ø5/16"x2"	5 PCS
C		Bolt	Ø5/16"x3-1/4"	4 PCS
D		Spring Washer	Ø5/16"	9 PCS
E		Flat Washer	Ø5/16"xØ23mm	9 PCS

STEP 1

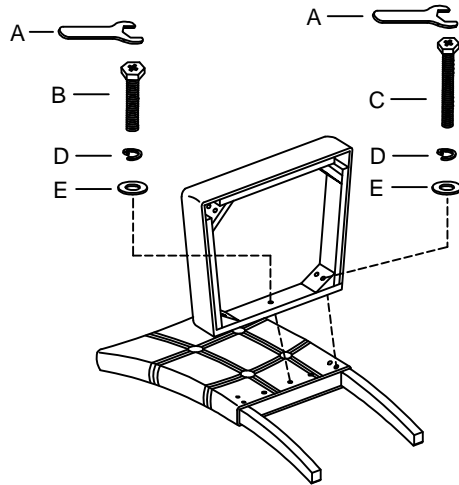

STEP 2

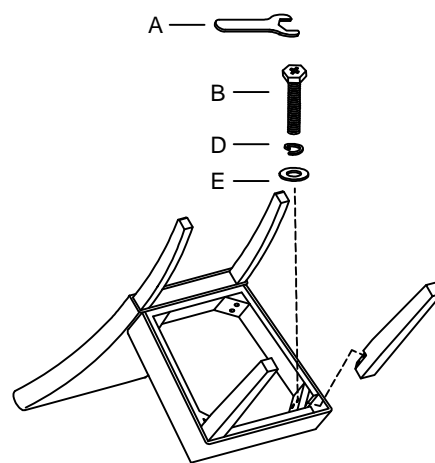

COMPLETED

