

ASSEMBLY INSTRUCTIONS

UPHOLSTERED DINING CHAIR

Thank you for purchasing this quality product. Be sure to check all packing material carefully for small parts that may have come loose inside the carton during shipment.

Parts key			Hardware kit		
No	Qty	Description	No	Description	Qty
1	1 pc	Chair Back	A	Hex nut M8	4 pcs
2	1 pc	Complete Seat	B	Lock washer Ø8 x13mm	11 pcs
3	2 pcs	Front Leg	C	Flat washer Ø8 x18mm	11 pcs
4	4 pcs	Floor Glide	D	Long bolt Ø6 x 80mm	4 pcs
			E	Short bolt Ø6 x 40mm	3 pcs
			F	Allen key	1 pc
			G	Key wrench	1 pc

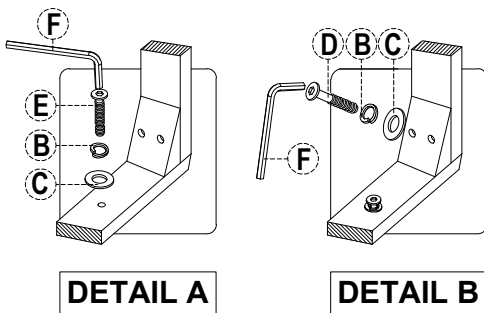

STEP 1

- Carefully lay Chair Back flat on a smooth flat surface to prevent scratches.
- Attach Complete Seat to Chair Back by inserting a Flat Washer, Lock Washer and Short bolt into each of the hole on the back of the seat. Tighten screws with provided Allen Key by turning clockwise until secure. (See Detail A).
- Insert a Flat Washer, Lock Washer and Long screw into each of 2 holes in the Complete Seat corners. Tighten screws with provided Key Wrench. (See Detail B).

FABRIC CARE INSTRUCTIONS

REGULAR CARE

Blot gently using a clean soft damp cloth and mild detergent **DO NOT SATURATE**

FABRIC CONTENT:

100% Polyester - Cleaning code W

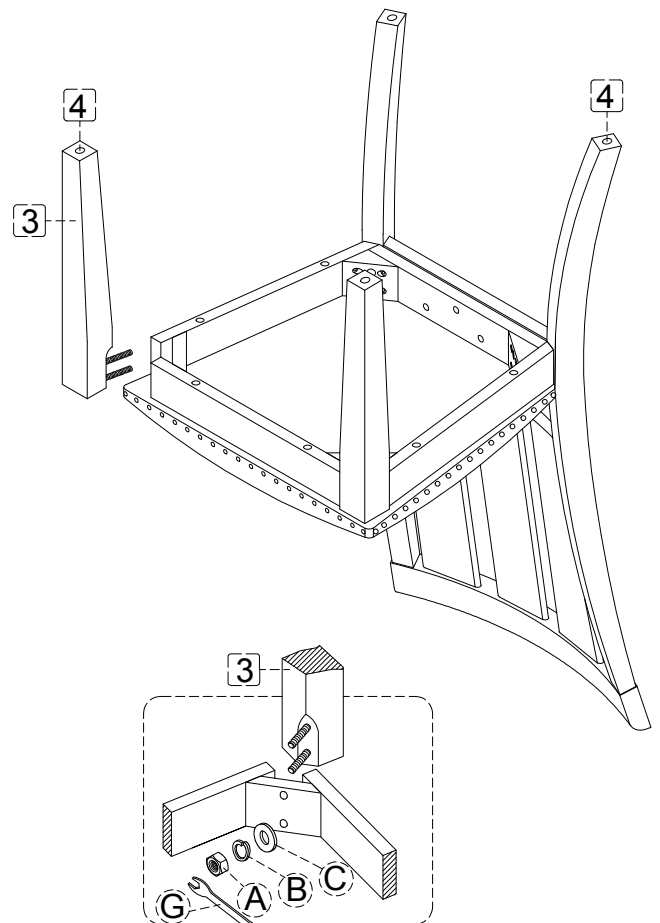
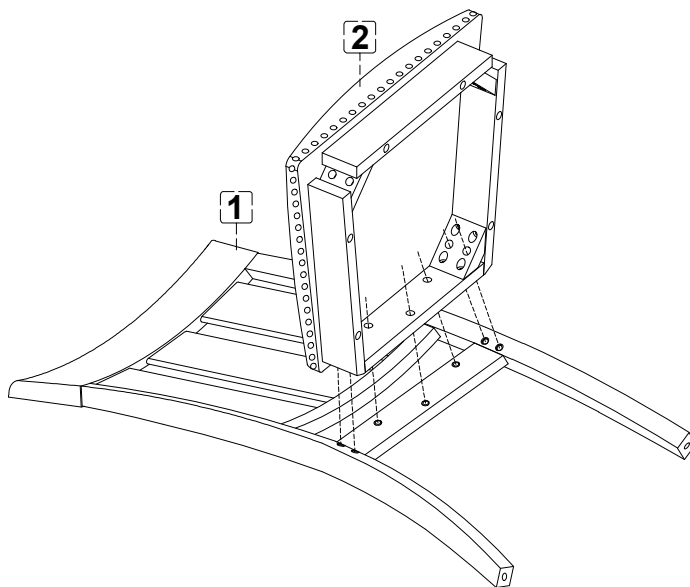

STEP 2

- Carefully turn chair upside down and attach each Leg to the front corners of the Complete Seat. Place Flat Washer, Lock Washer and Nut on each leg bolt, tightening the Nut on each Leg using provided Key Wrech. (See Detail C).
- Be sure to level the chair prior to tightening all the nuts/screws.

DETAIL C