

## NOTICE

\*Please make sure that you have all part indicated and they are in good condition before you begin assembly of this item. Refer to part list and hardware list below for guidance.

\*This item should be assembled on a soft surface to prevent scratching the finish during assembly.

\*This item may require periodic tightening.

\*If you are having difficulty, our friendly Customer Care team is always here to help. Please email [customersupport@safavieh.com](mailto:customersupport@safavieh.com)

## PREPARATION

\*Before beginning assembly of product, make sure all part are present. Compare part with part contents list and hardware contents list.

\*If any part is missing or damaged, do not attempt to assemble the product.

\*Estimated Assembly Time: 60 minutes.

\*Tools Required for Assembly (Not included): Screwdriver

## CARE AND MAINTENANCE

Adhesive felt pads should always be applied to areas of furniture which make direct contact with flooring, said application will prevent damage to the furniture and or surfaces on which the furniture lies.

Objects placed on articles of furniture should rest on non abrasive material as to prevent damage to the wood finish. Objects whose composition consists of plastic and rubber are known to discolor and damage the wood surfaces on which they rest. Wipe up spills immediately and avoid common hazards such as hot dishes, harsh solvents and abrasives. Cleaning should be done with a soft lint free cotton cloth dampened with water or furniture polish. On highly used surfaces we recommend applying a quality paste wax which should be used on a regular basis to provide additional protection from scratches and spills.

How often you apply the wax depends on how much wear the furniture receives

## Part List

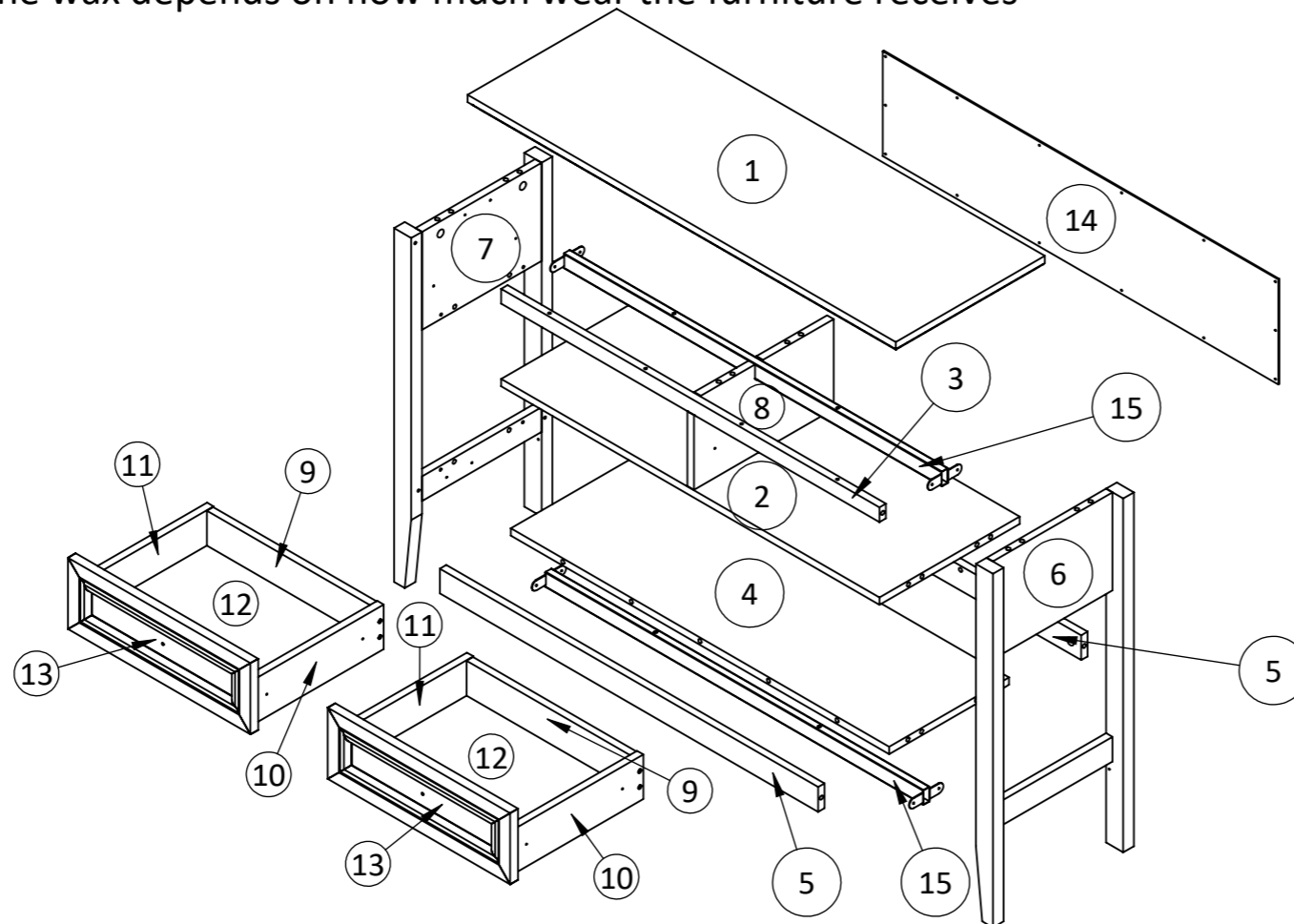

 **SAFAVIEH**  
FURNITURE

**Model# CNS3102**

**Product Dimensions: W 39.4" X D 12.6" X H 29.5"**

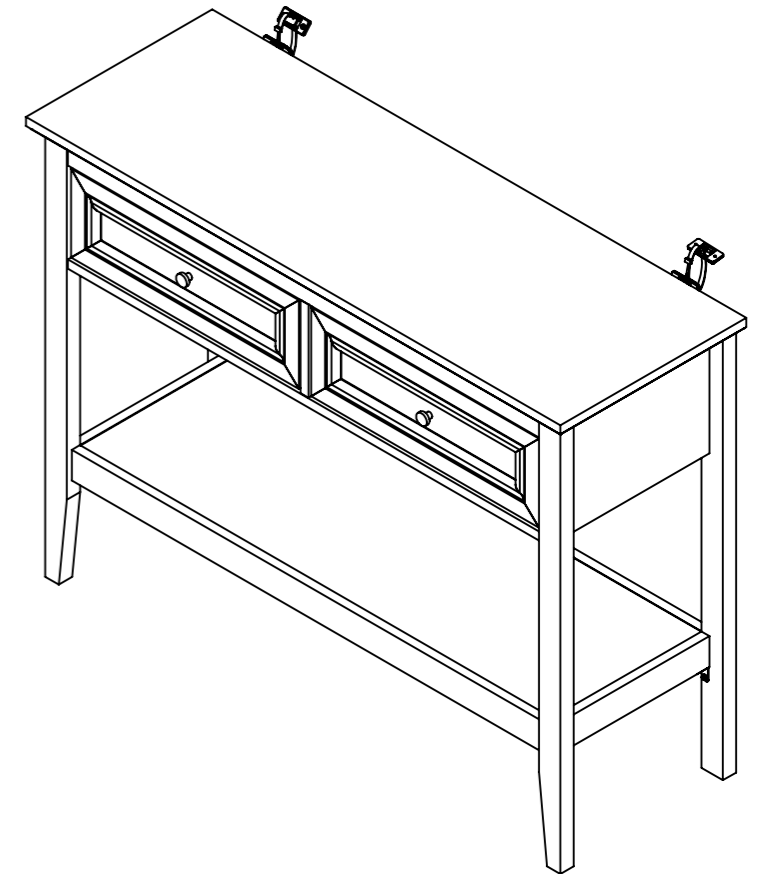

### WARNING

TOTAL WIGHT CAPACITY: 71 LBS

Top load capacity: 37 lbs







Drawer load capacity: 4 lbs

Shelf load capacity: 30 lbs

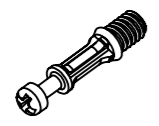
Warning : Do not stand on the console

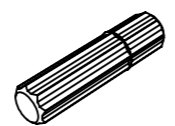
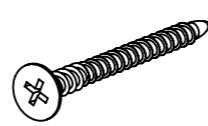
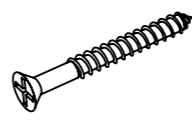
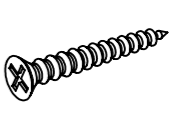
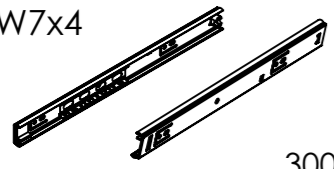
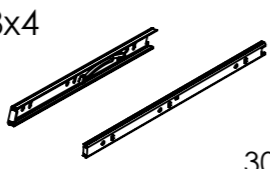
Warning : Do not over torque bolts

## Hardware List

<p>HW1x30</p>  <p>Ø6x32 mm</p>	<p>HW2x30</p>  <p>Ø15x12 mm</p>	<p>HW3x24</p>  <p>Ø8x32 mm</p>	<p>HW4x6</p>  <p>Ø6x50 mm</p>	<p>HW5x4</p>  <p>Ø8x37 mm</p>	<p>HW6x8</p>  <p>Ø7x32 mm</p>
<p>HW7x4</p>  <p>300 MM</p>	<p>HW8x4</p>  <p>300 MM</p>	<p>HW9x38</p>  <p>Ø6x12 mm PH</p>	<p>HW10x2</p>  <p>handle Ø20 mm</p>	<p>HW11x2</p>  <p>panhead Ø9x10 mm</p>	<p>HW12x10</p>  <p>Cover Cap sticker Ø20 mm</p>

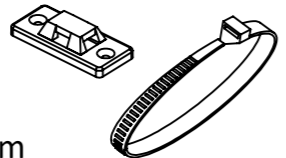
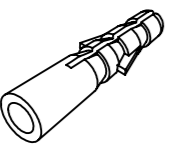
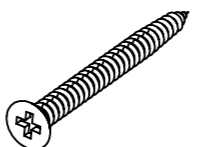
ANTI-TIP RESTRAIN PACK	
<p>HW13x4</p>  <p>Ø6x15 mm</p>	<p>HW14x2</p>  <p>300 mm</p>
<p>HW15x4</p>  <p>Ø8x35 mm</p>	<p>HW16x4</p>  <p>Ø10x50 mm</p>

## Part List & HW

Piece	Description	Qty	Carton Call
1	Top Panel	1	1 of 1
2	Bottom Panel - upper	1	1 of 1
3	Plint - upper	1	1 of 1
4	Bottom panel - lower	1	1 of 1
5	Plint - lower	2	1 of 1
6	Side panel - right	1	1 of 1
7	Side panel - left	1	1 of 1
8	Center panel	1	1 of 1
9	Back drawer	2	1 of 1
10	Right Side Drawer	2	1 of 1
11	Left Side Drawer	2	1 of 1
12	Base Drawer	2	1 of 1
13	Front Drawer	2	1 of 1
14	Back panel	1	1 of 1
15	Metal support	2	1 of 1

Piece	Description	Qty	Carton Call
HW1	Cambolt $\varnothing$ 6x32 mm	30	1 of 1
HW2	Camlock $\varnothing$ 15x12 mm	30	1 of 1
HW3	Wooden Dowel 8x32 mm	24	1 of 1
HW4	Screw M6x50 mm	6	1 of 1
HW5	Screw M8x37 mm	4	1 of 1
HW6	Screw M7x32 mm	8	1 of 1
HW7	Metal Runner 1 L. 300 mm	4	1 of 1
HW8	Metal Runner 2 L. 300 mm	4	1 of 1
HW9	Screw M6x12 mm PH	38	1 of 1
HW10	Handle $\varnothing$ 20 mm	2	1 of 1
HW11	Panhead $\varnothing$ 9x10 mm	2	1 of 1
HW12	Cover cap sticker $\varnothing$ 20 mm	10	1 of 1
HW13	Screw M6X15 mm	4	1 of 1
HW14	Anti-tip 300 mm	2	1 of 1
HW15	Fisher "S" 8x35 mm	4	1 of 1
HW16	Screw M10x50 mm	4	1 of 1

## Special Tips for Fitting Minifix Cam ( Cam-Lock ), and Minifix Bolt ( Cam-Bolts )

### CAM-BOLT

Tighten until shoulder is flush with panel. Do not overtighten or undertighten (see example below)

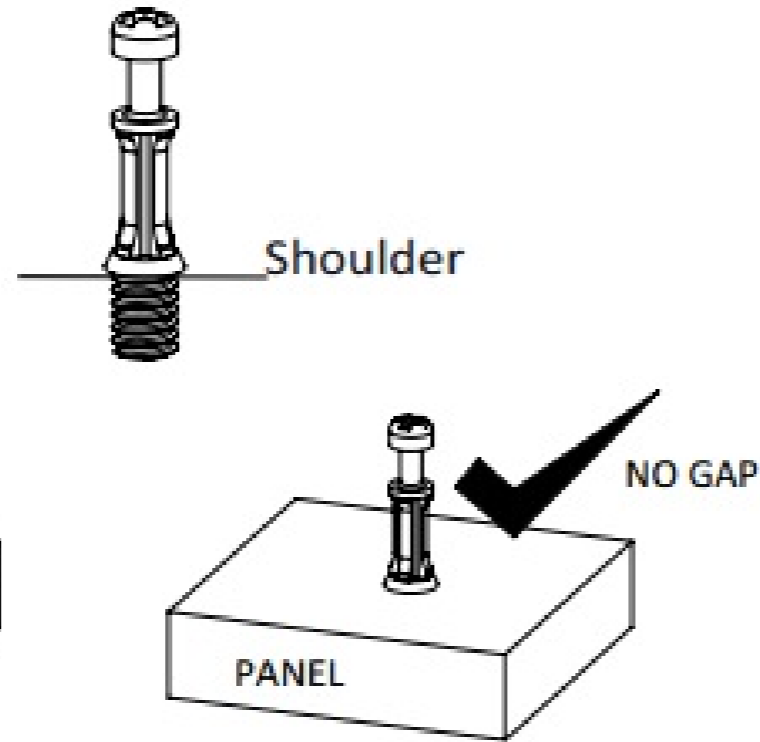

### CAM-LOCK

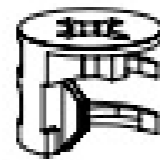

See this Arrow Points !

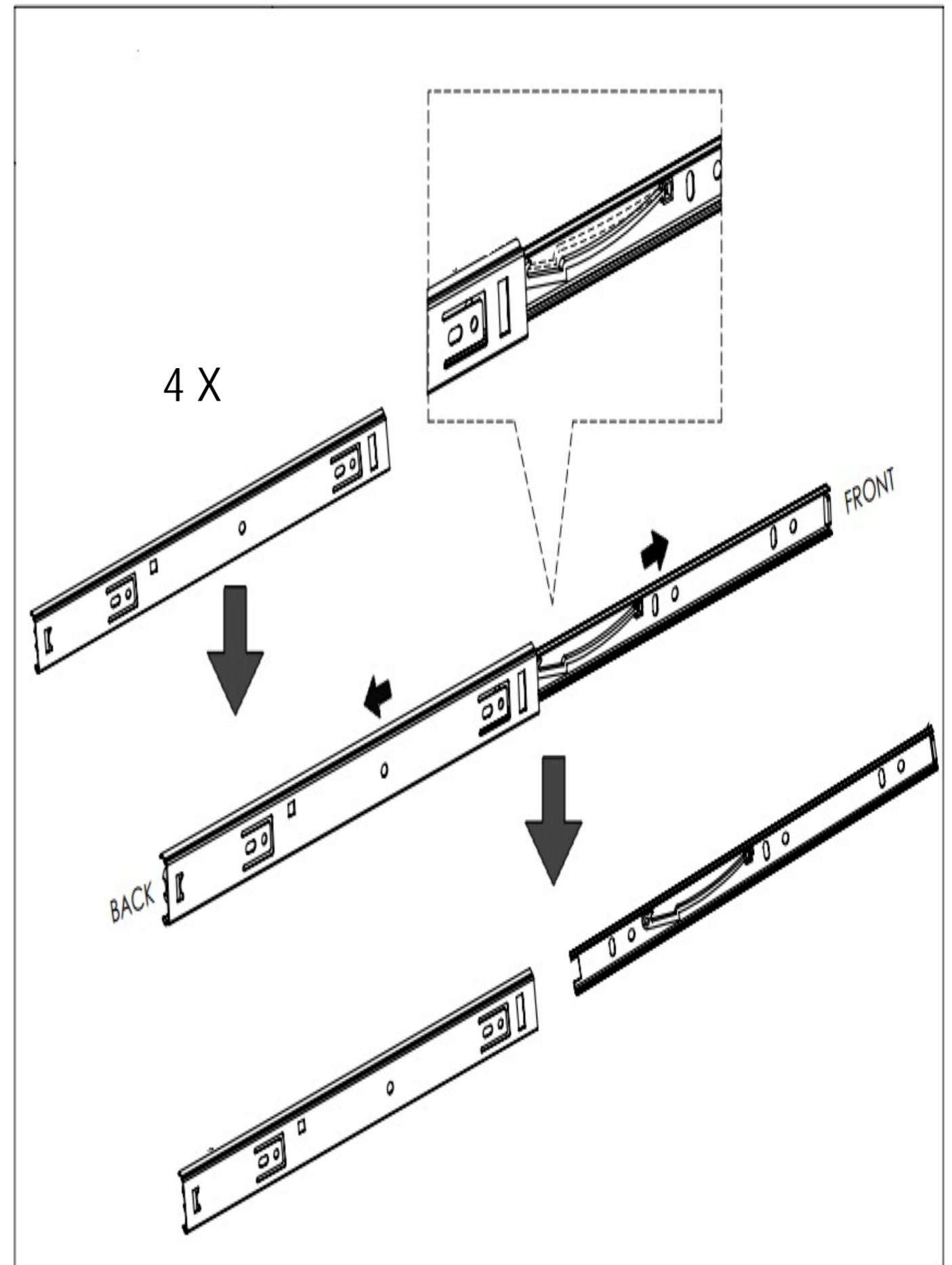
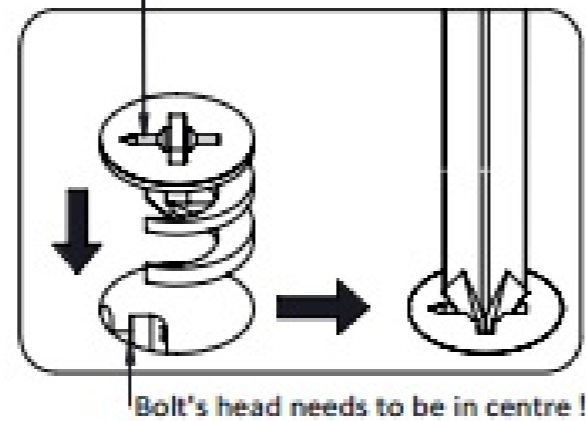
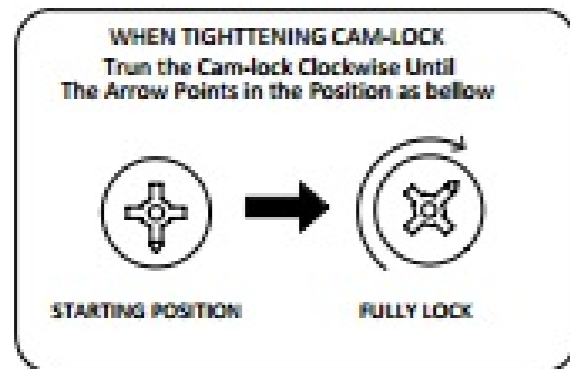

## PREPARATION

Before beginning assembly of product, make sure all part are present. Compare part with part contents list and hardware contents list.

If any part is missing or damaged, do not attempt to assemble the product.

Estimated Assembly Time: 60 minutes.

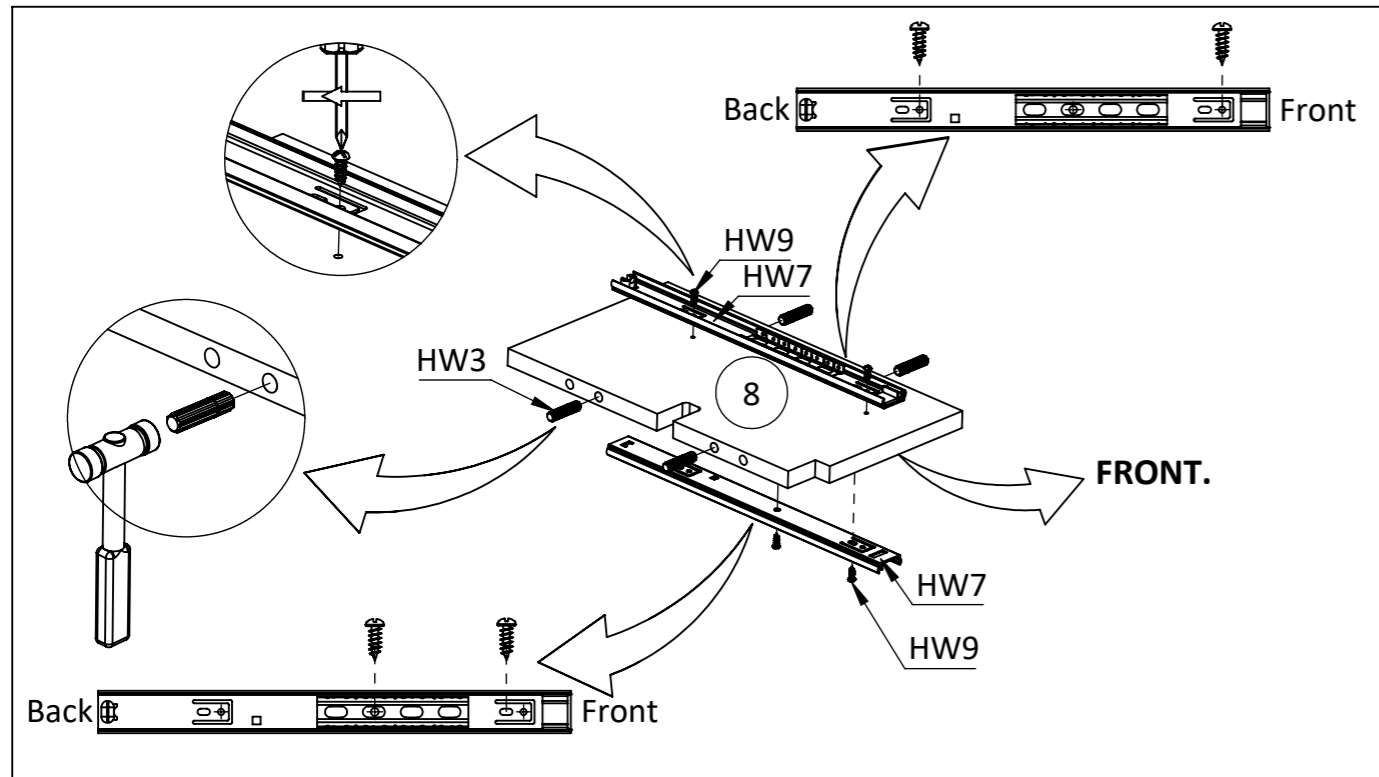

**STEP1:** Insert wooden dowel (HW3), runner 1 (HW7) and screw M6x12 PH (HW9) into center panel (8) tighten it using screwdriver.

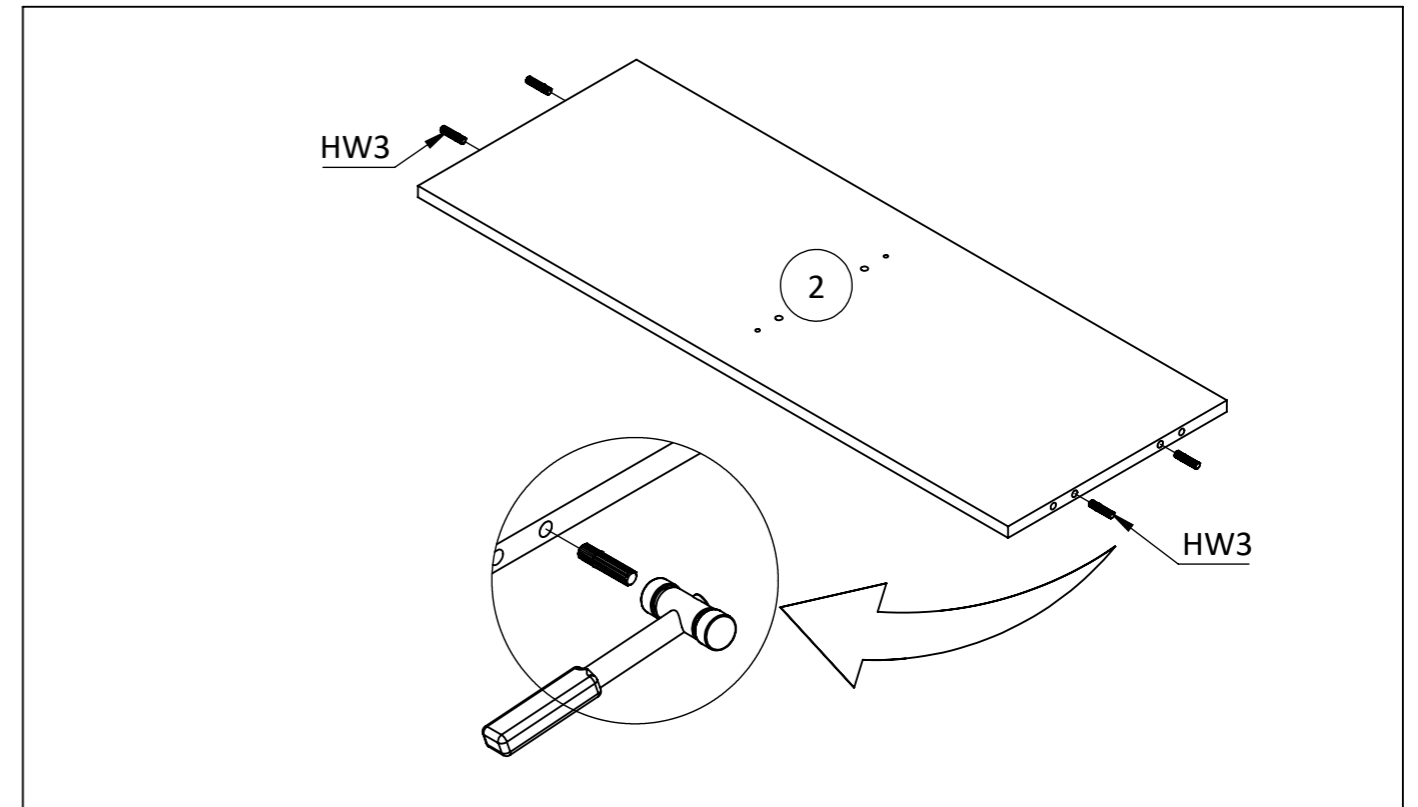

**STEP2:** Insert wooden dowel (HW3) into bottom panel (2).

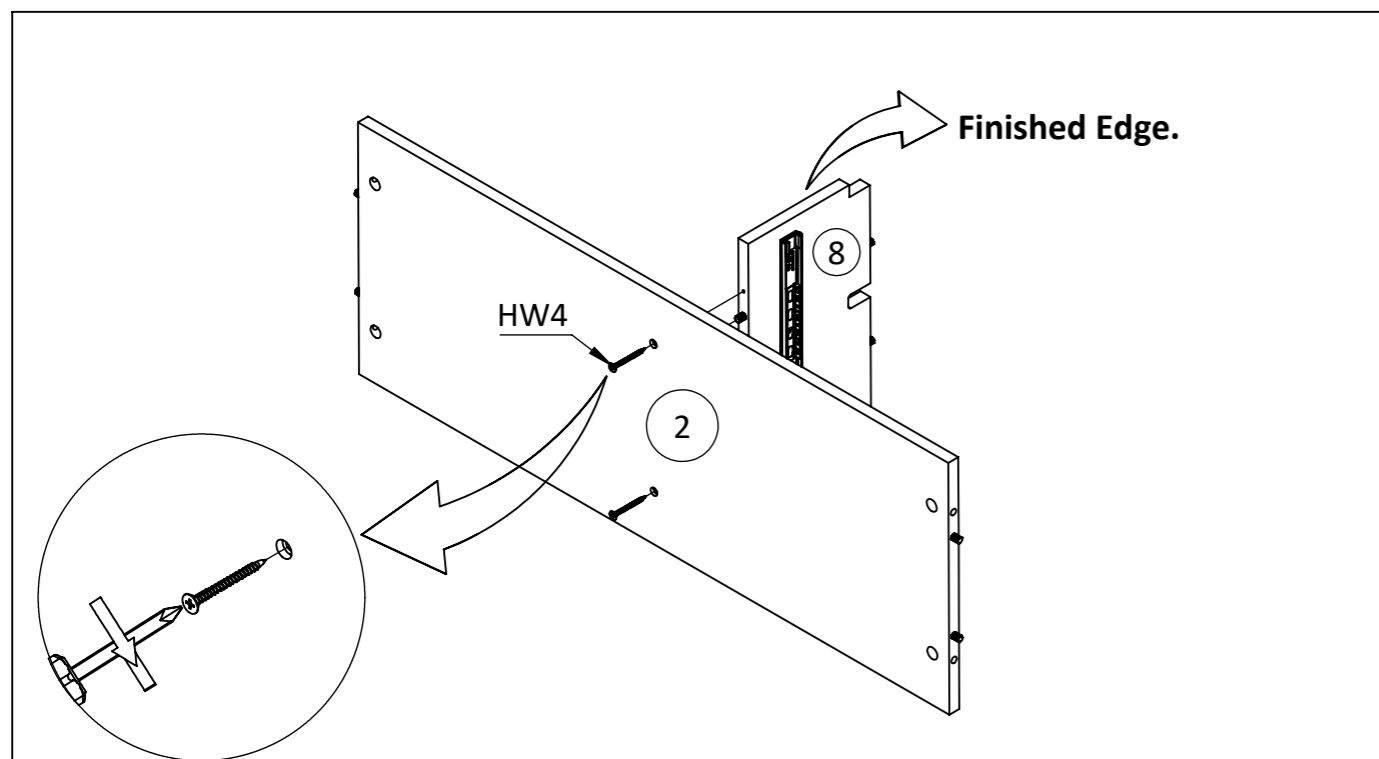

**STEP3:** Attach center panel (8) into bottom panel - upper (2) secure with screw M6x50 mm (HW4) tighten it using screwdriver.

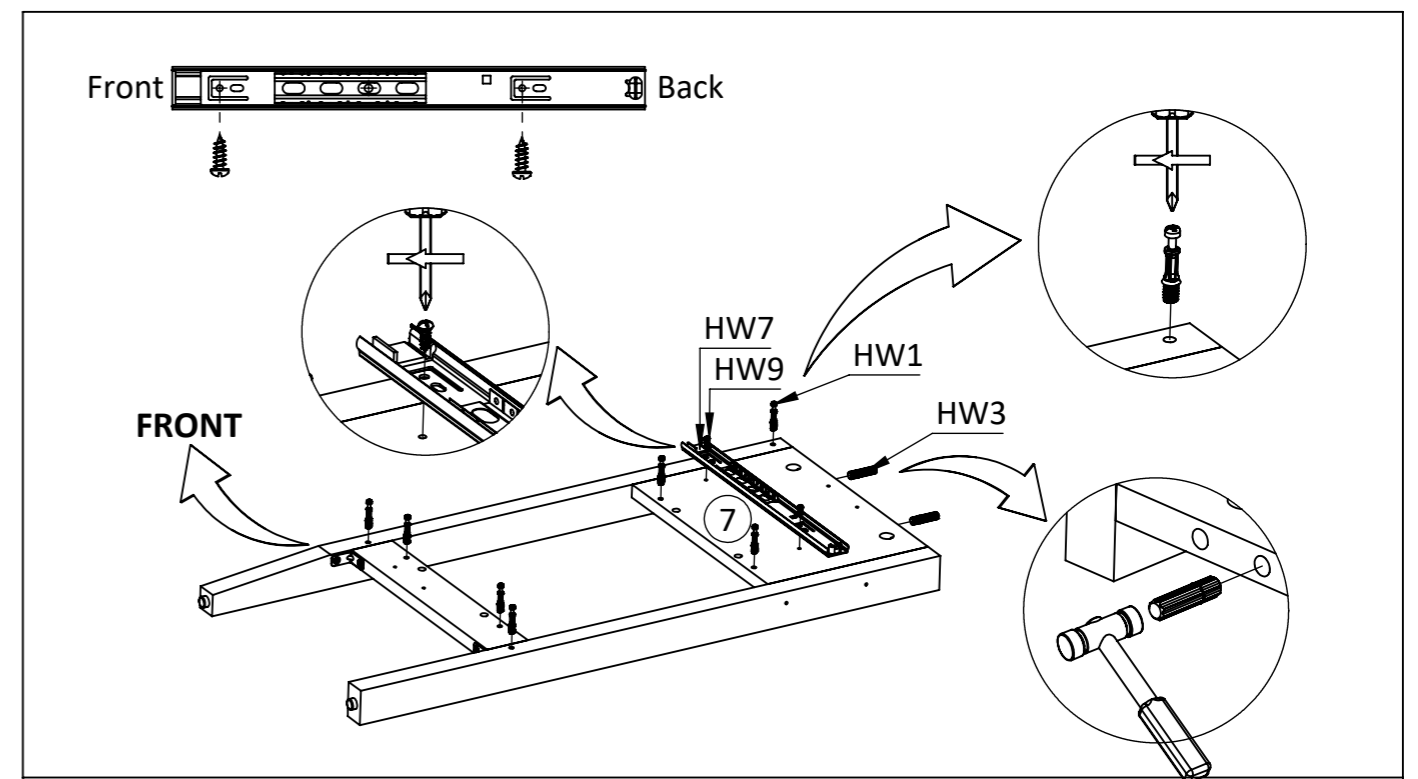

**STEP4:** Insert wooden dowel (HW3), cambolt (HW1), runner 1 (HW7) and screw M6x12 mm PH (HW9) into side panel - left (7) tighten it using screwdriver.

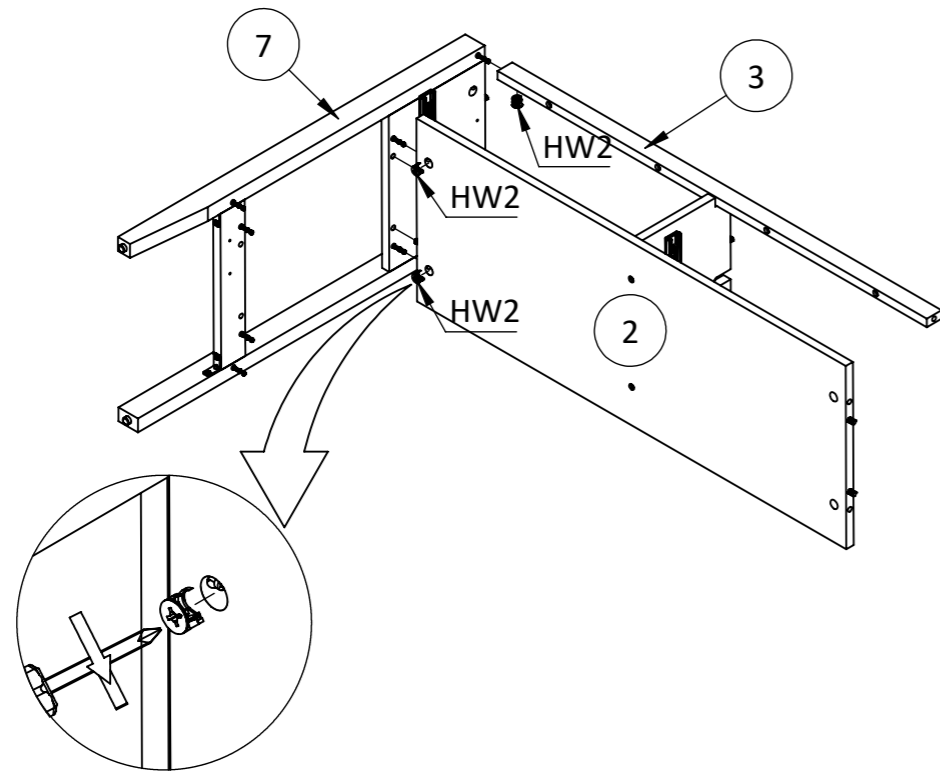

**STEP5:** Attach bottom panel - upper (2) and plint - upper (3) into side panel - right (6) secure with camlock (HW2) tighten it using screwdriver.

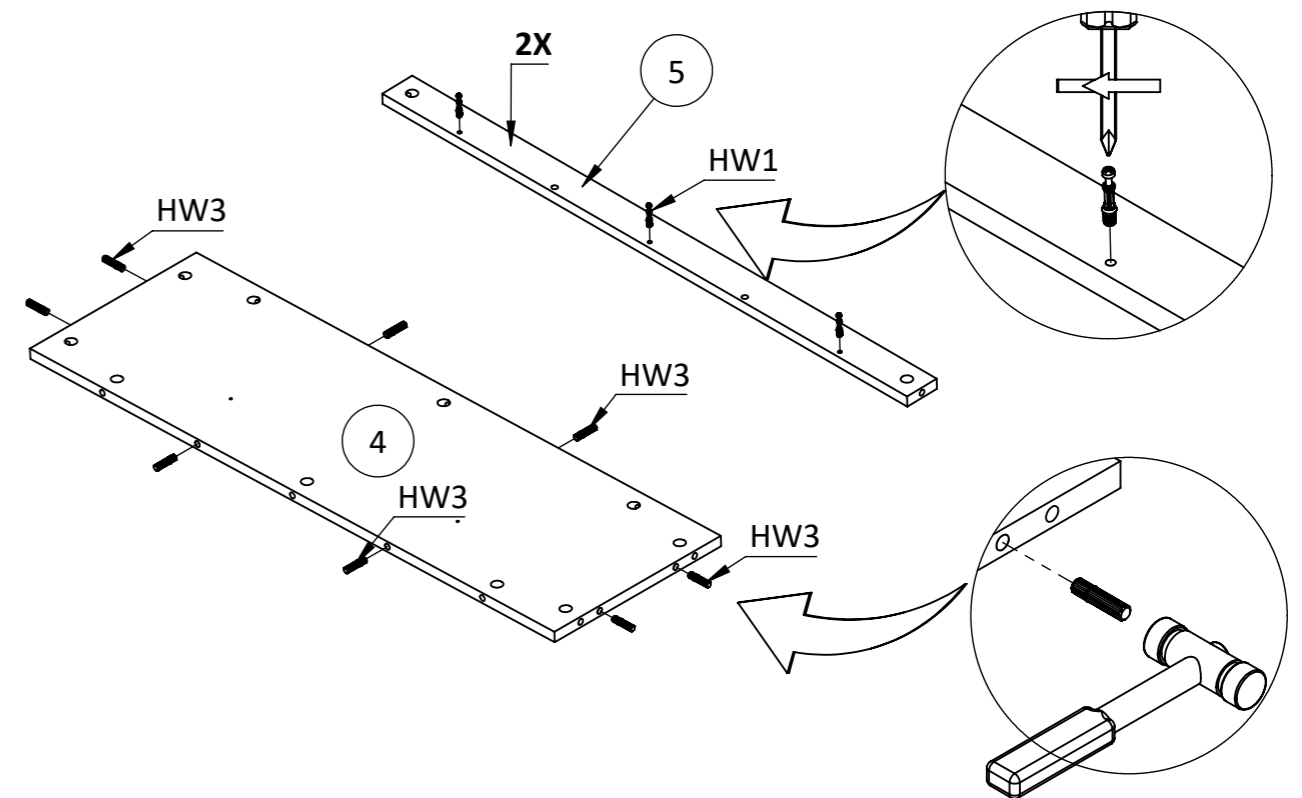

**STEP6:** Insert wooden dowel (HW3) into bottom panel - lower (4). insert cambolt (HW1) into plint - lower (5) tighten it using screwdriver.

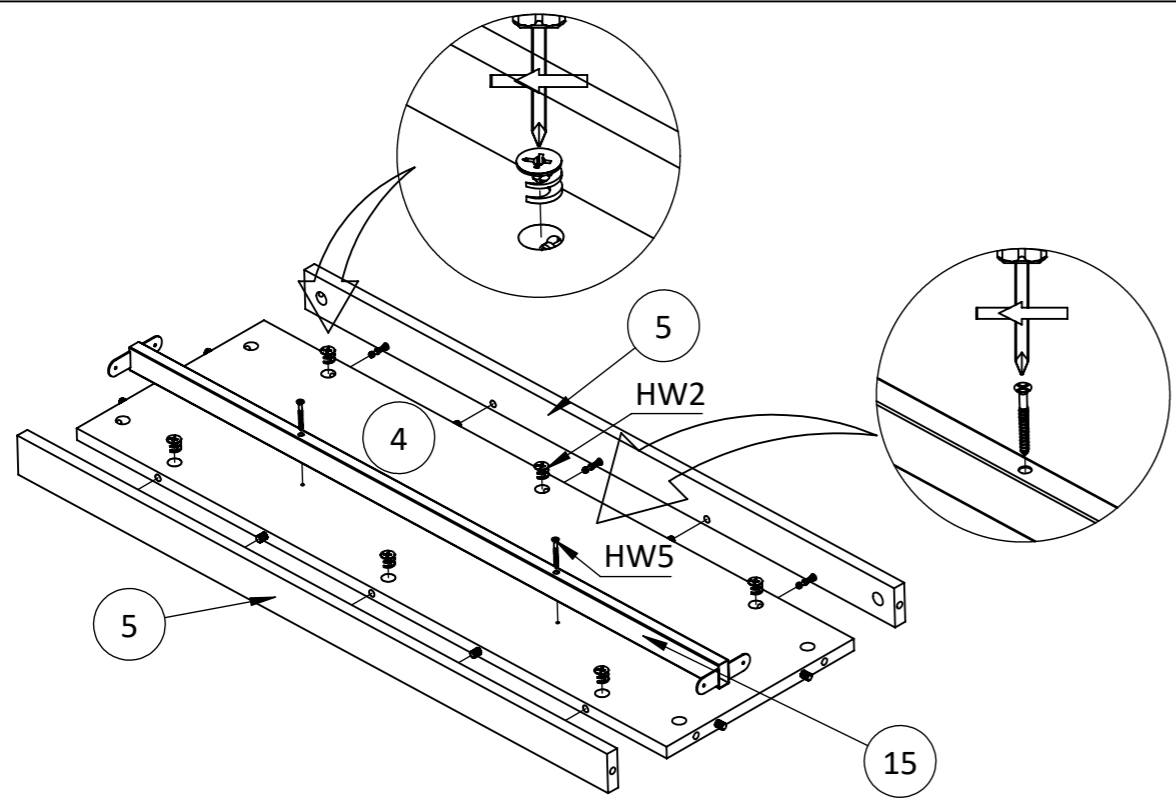

**STEP7:** Attach plint - lower (5) into bottom panel - lower(4) secure with camlock (HW2). Attach metal support (15) into bottom - lower (4) secure with screw M8x37 mm (HW5) tighten it using screwdriver.

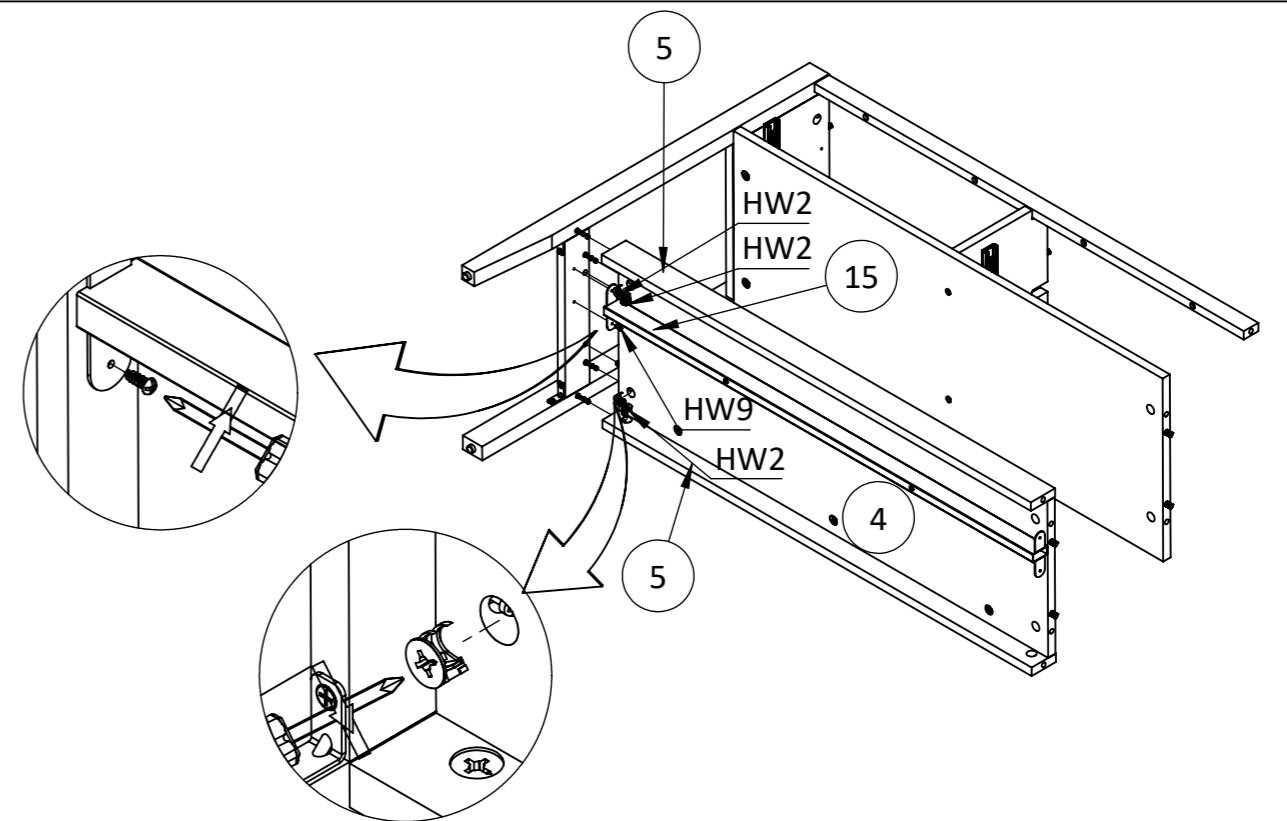

**STEP8:** Attach bottom panel - lower (4), plint - lower (5) and metal support (15) into side panel - left (7) secure with camlock (HW2) and screw M6x12 mm PH (HW9) tighten it using screwdriver.

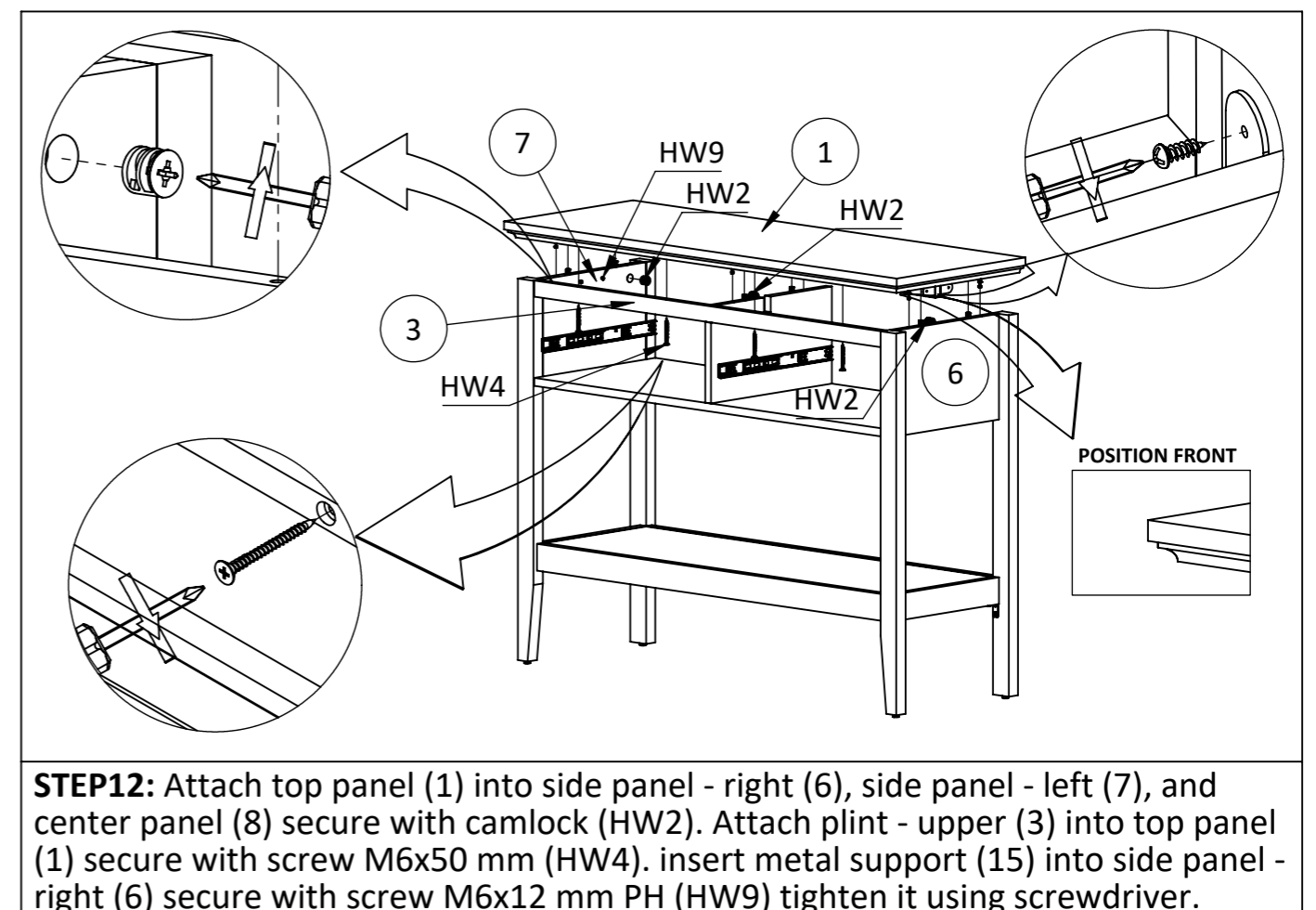
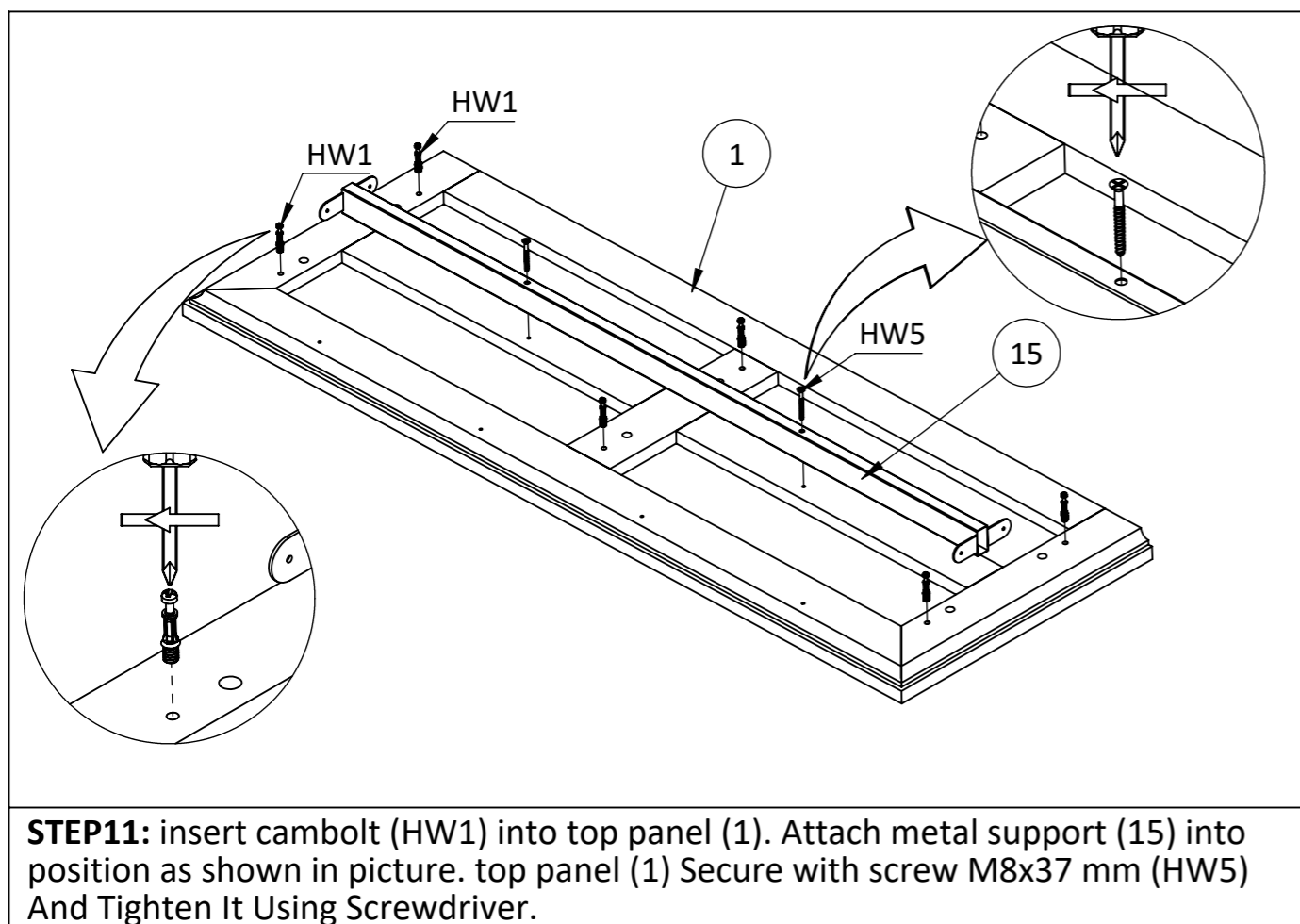
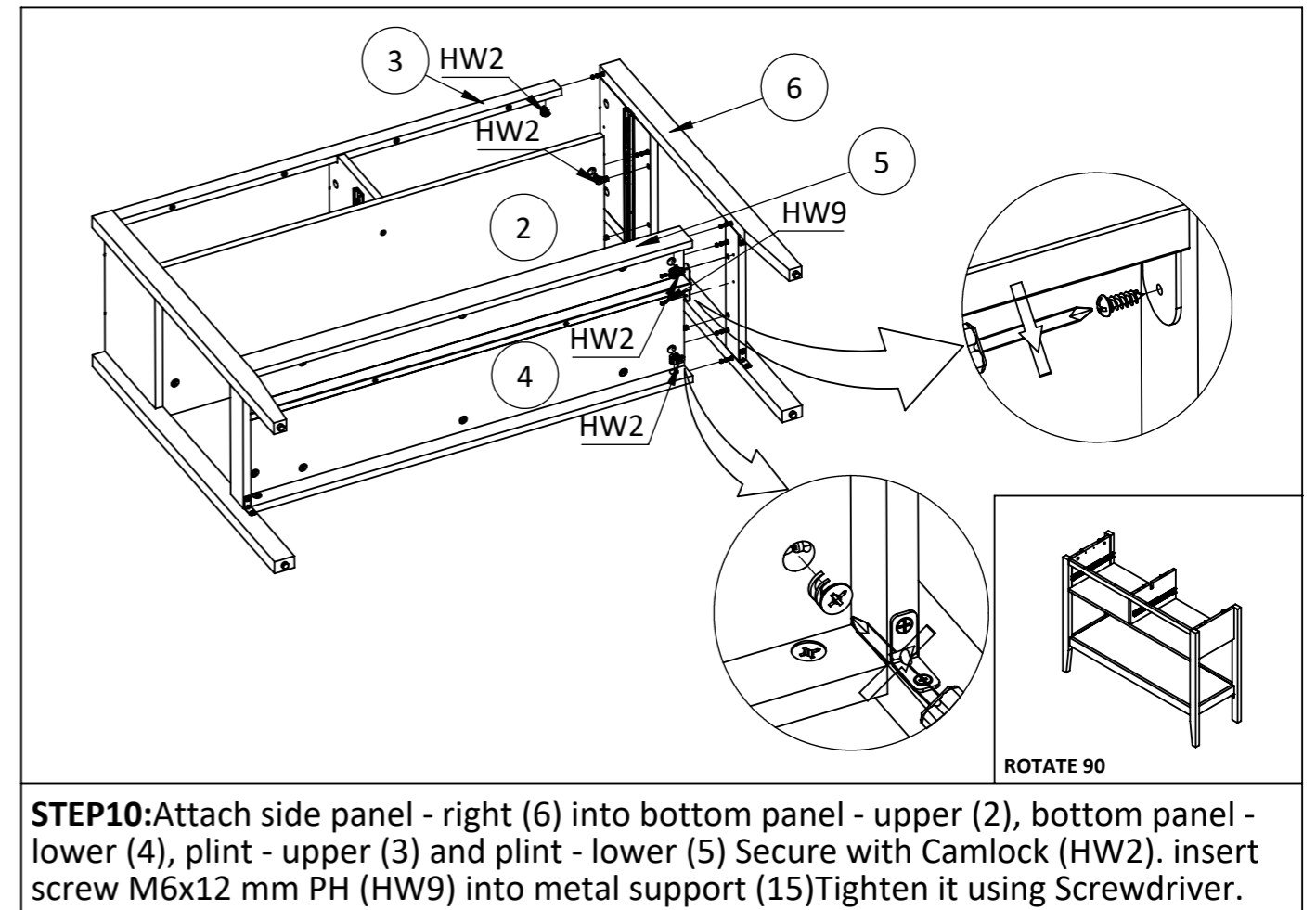
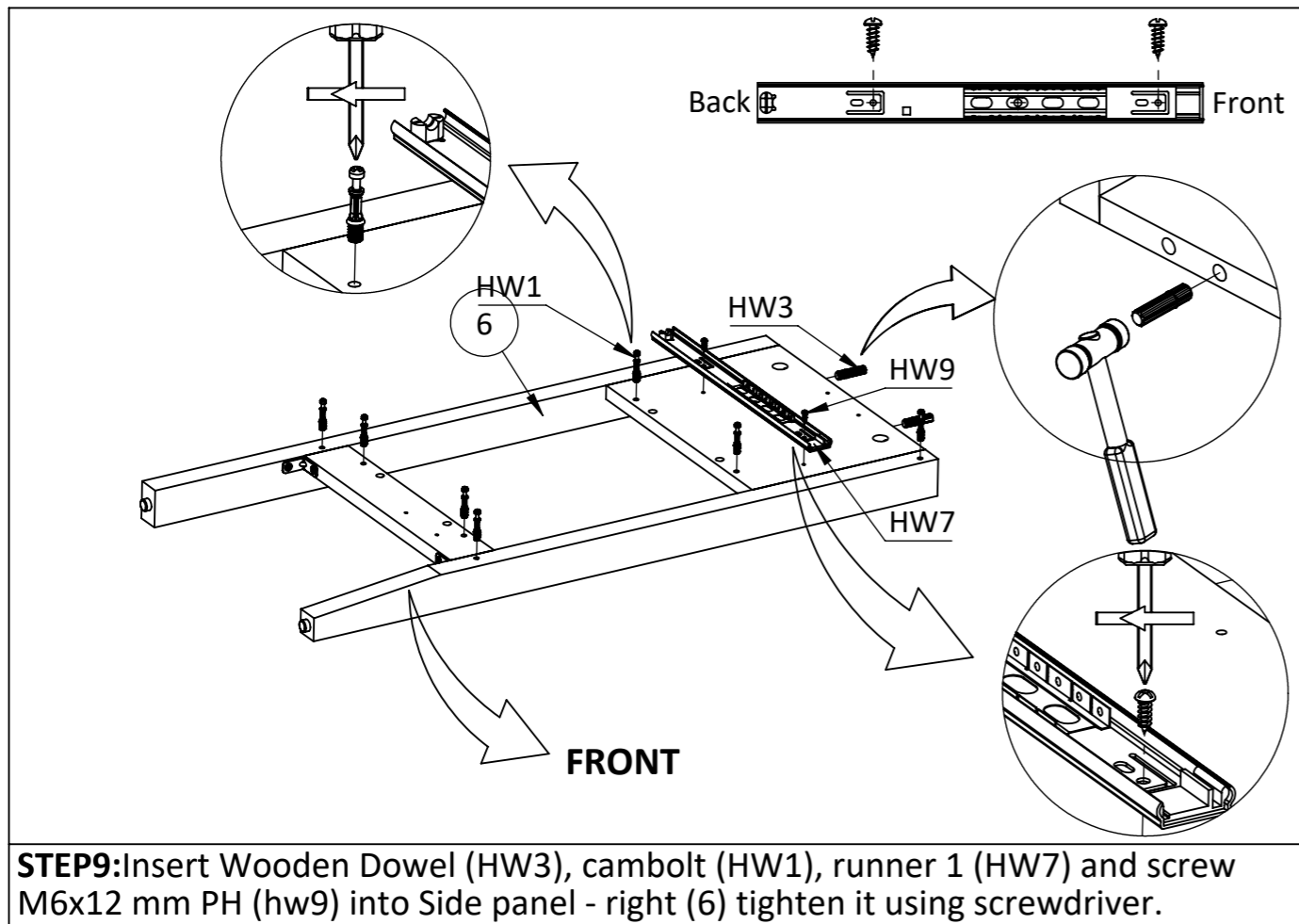

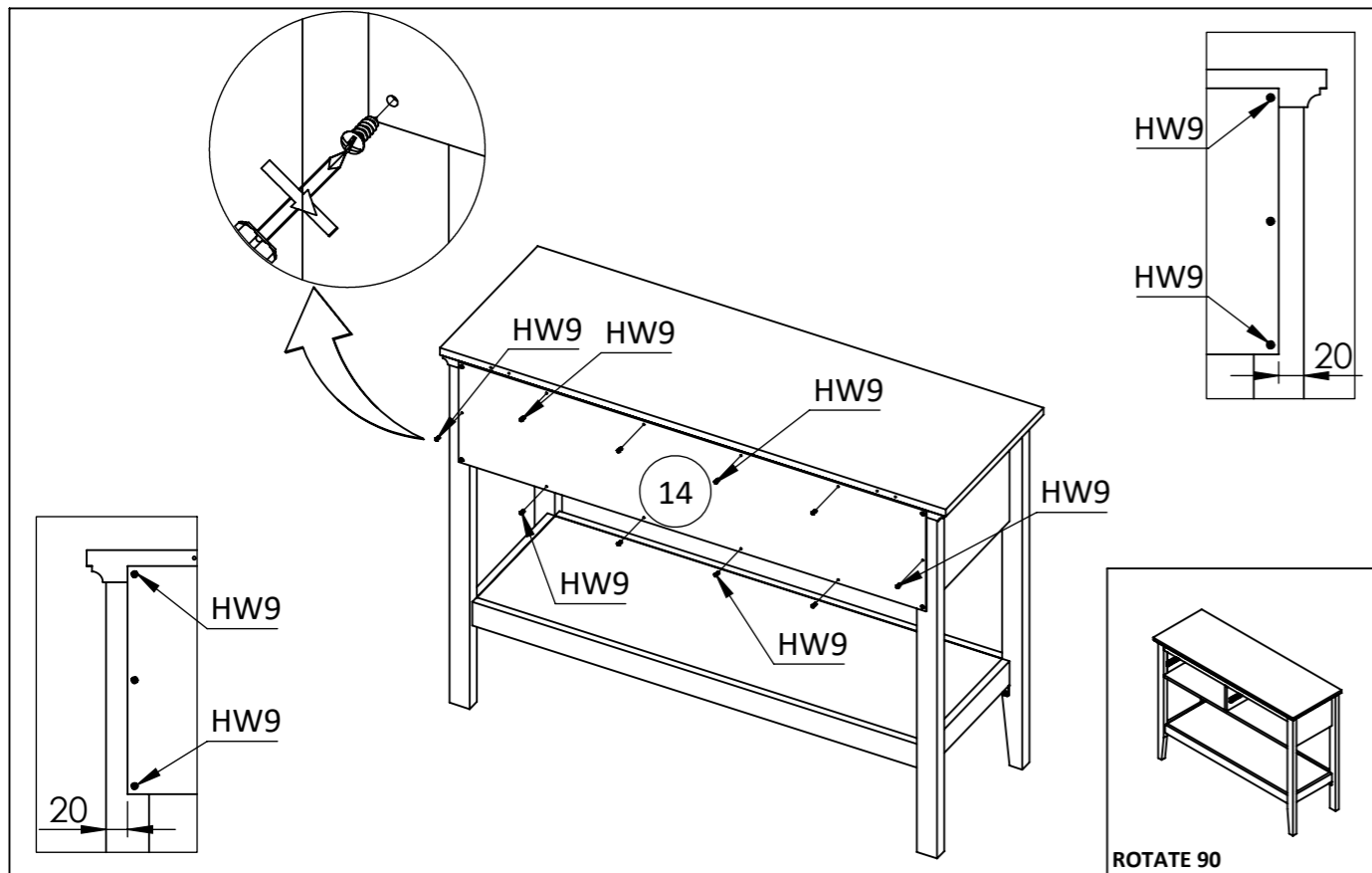

**STEP13:** Attach back panel (14) into top panel (1), side panel - right (6) and side panel - left (7) secure with screw M6x12 mm PH (HW9) tighten it using screwdriver.

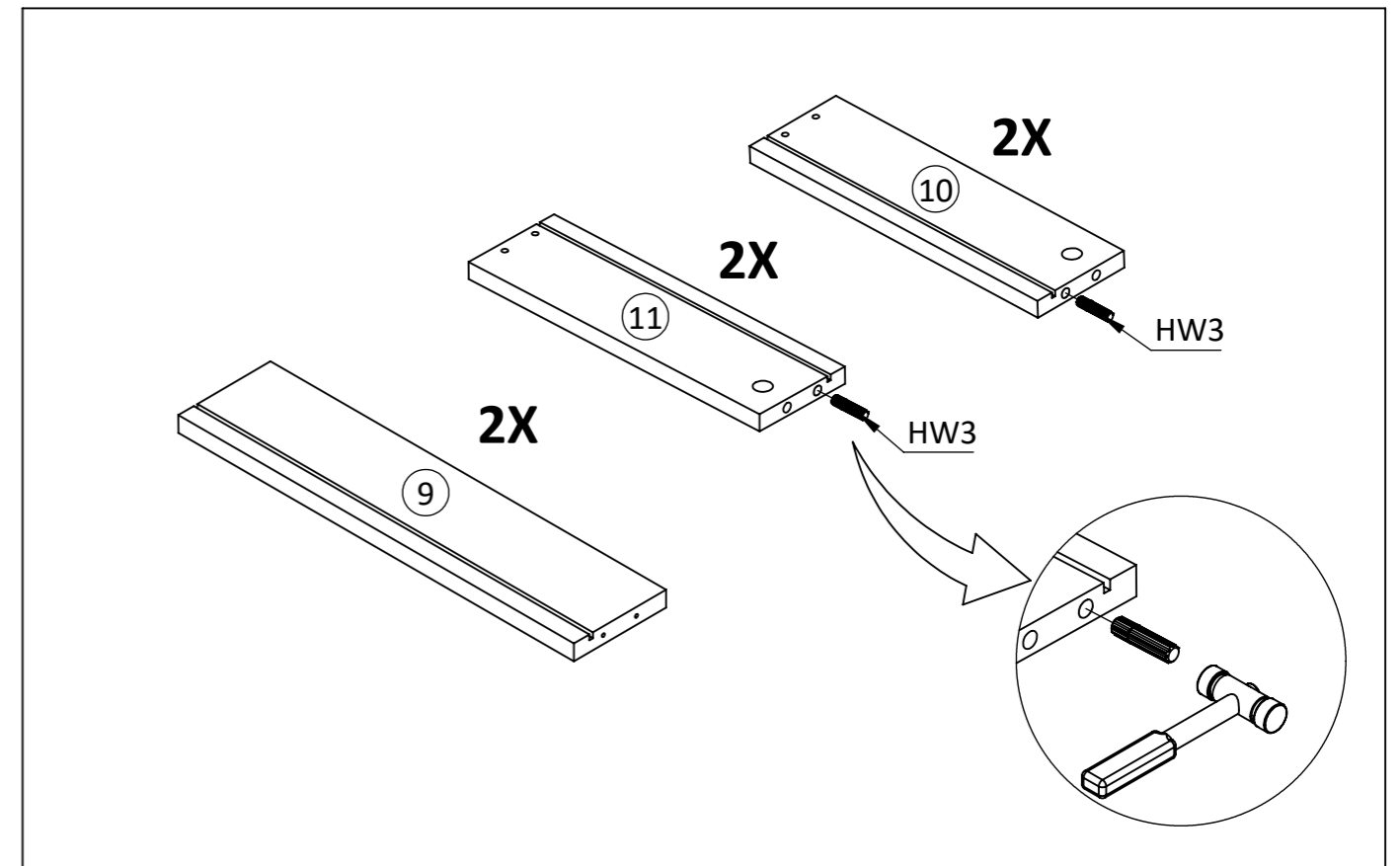

**STEP14:** Insert wooden dowel (HW3) into side drawer - right/left (10&11) tighten it using screwdriver.

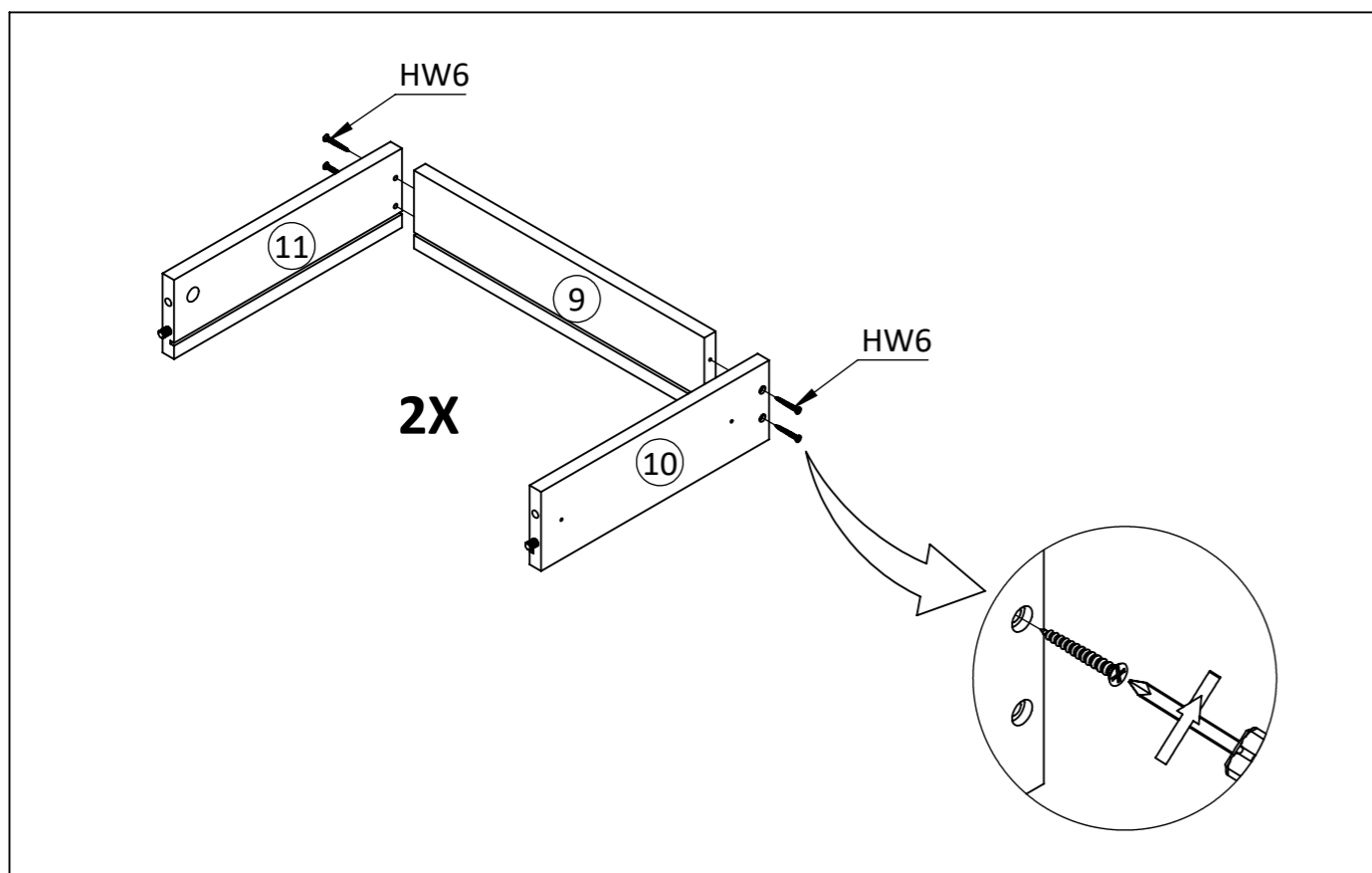

**STEP15:** Combine side drawer (10&11) into drawer back (9) secure with screw 7x32 mm (HW6) tighten it using Screwdriver.

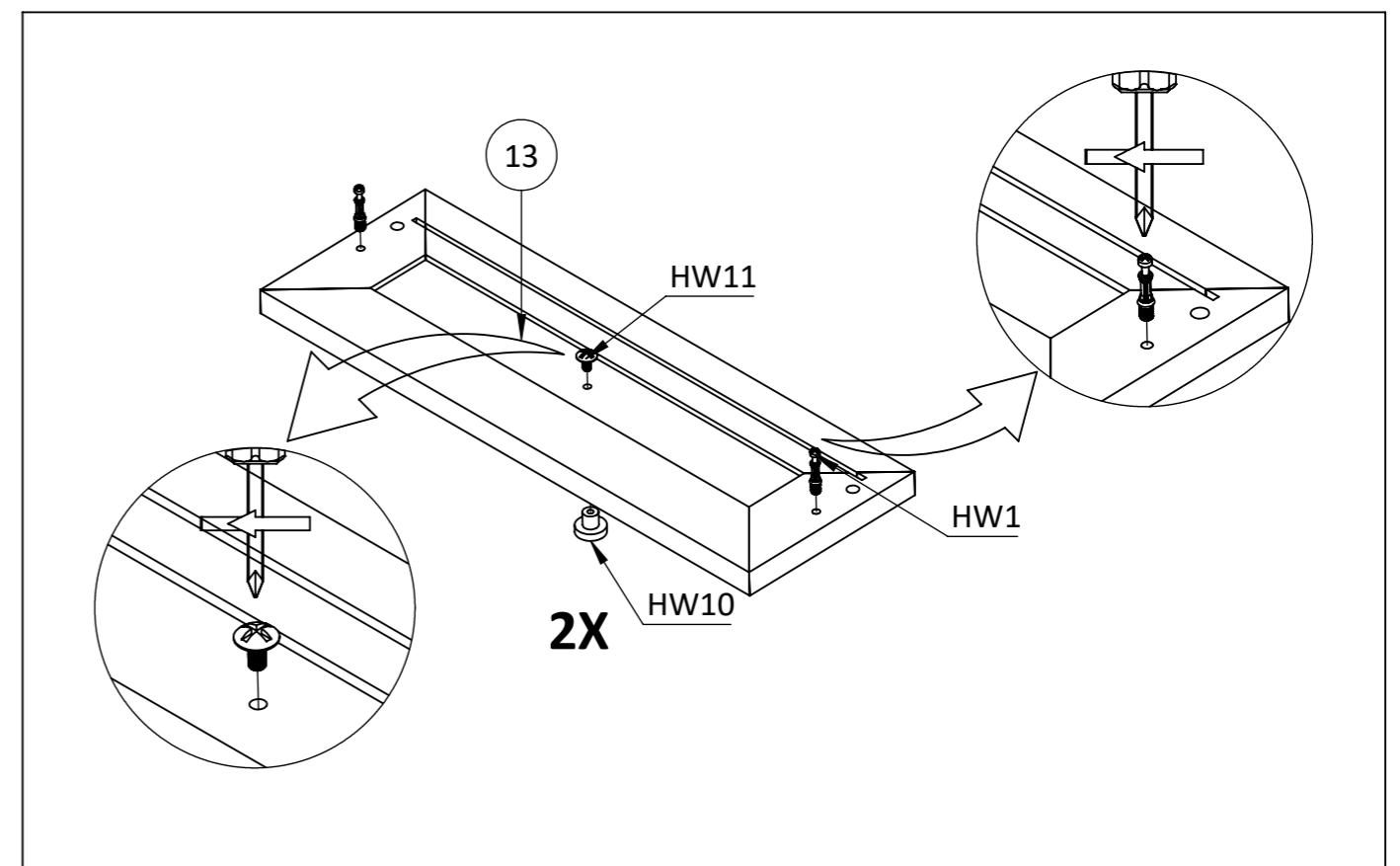

**STEP16:** Insert cambolt (HW1), handle  $\varnothing 20$  mm (HW10) and panhead M9x10 mm (HW11) into front drawer (13) tighten it using screwdriver.

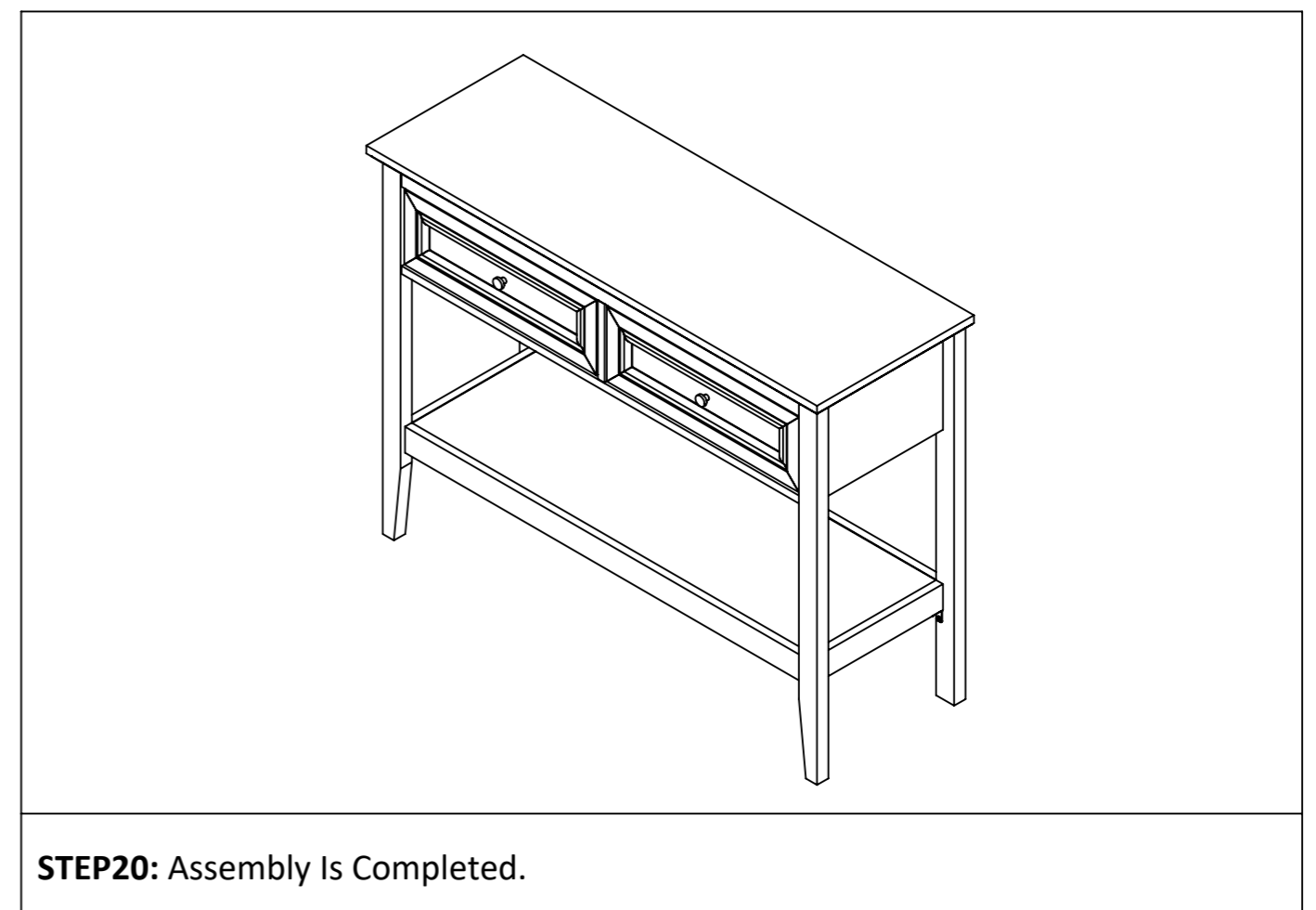
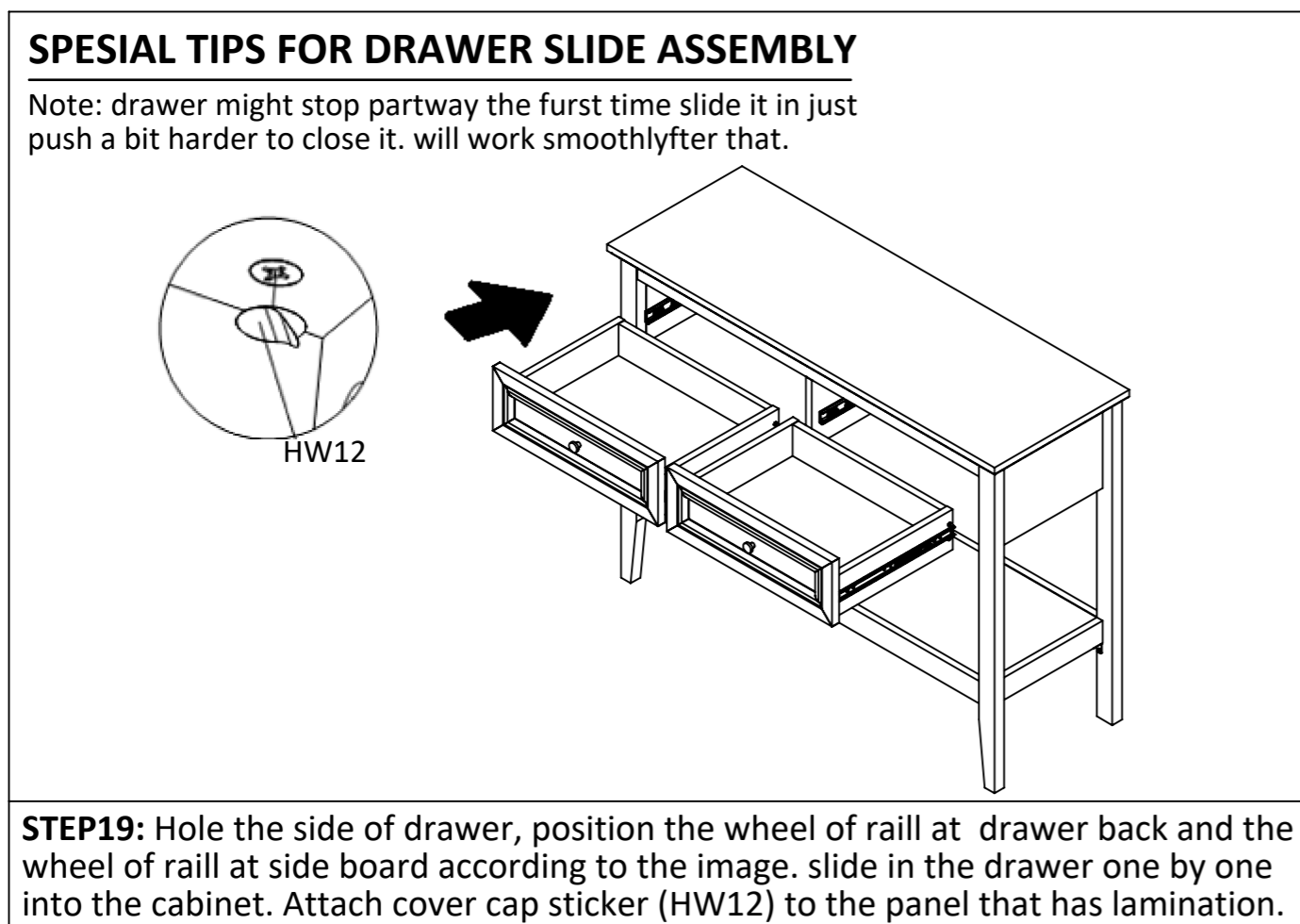
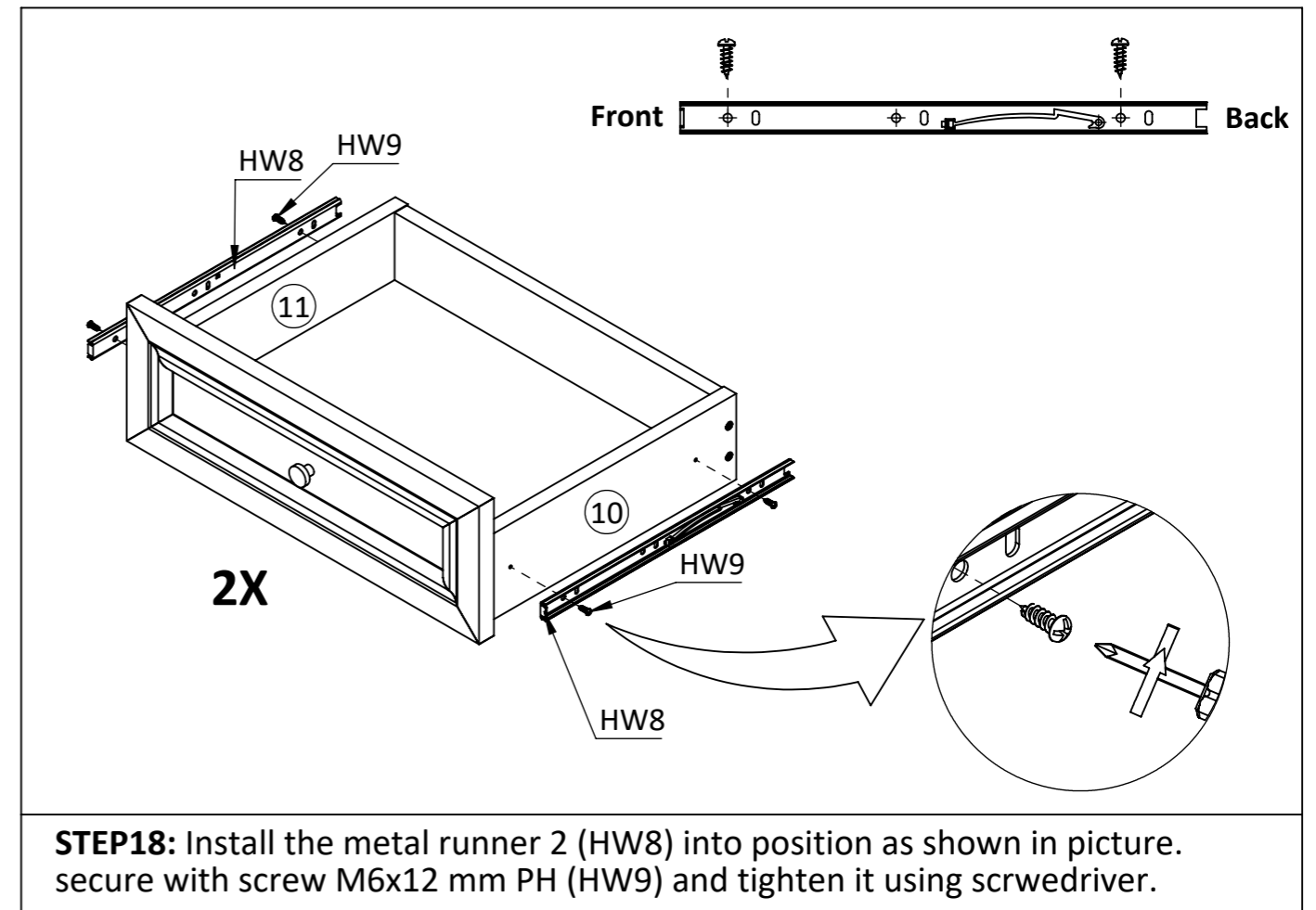
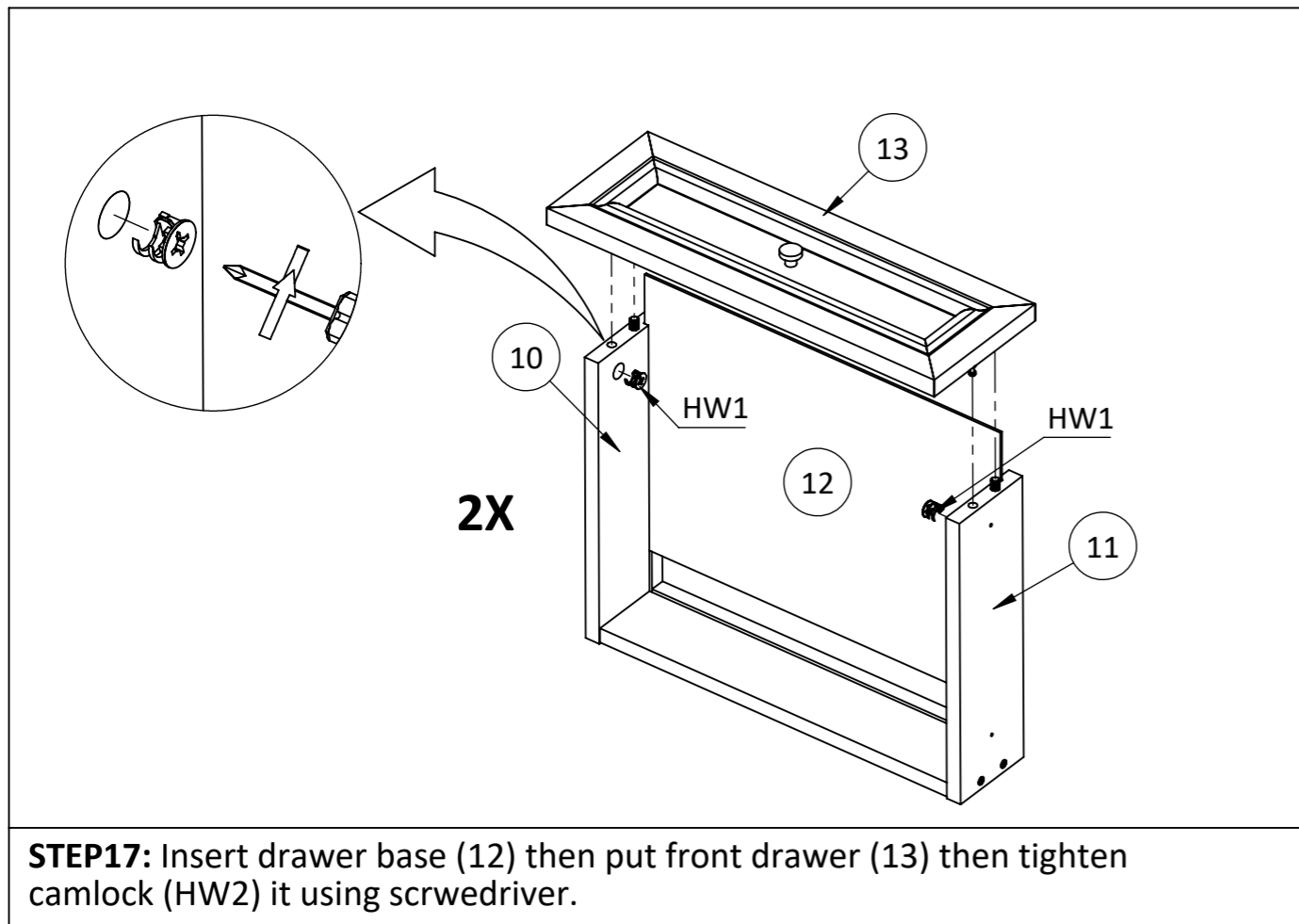



# ANTI-TIP RESTRAINT INSTALLATION

## ! WARNING!

Children have died from furniture tipover.  
To reduce the risk of furniture tipover:

- ALWAYS install tipover restraint provided.
- NEVER allow children to stand, climb or hang on drawers, doors, or shelves.
- NEVER open more than one drawer at a time.
- Place heaviest items in the lower drawers.

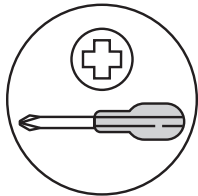
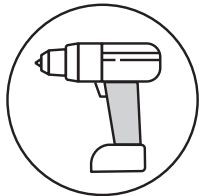

**REQUIRED TOOL**  
8MM / 5/16" DRILL BIT

**REQUIRED TOOL**

**!** Hardware (HW11 / HW7) to attach brackets to wall is designed for drywall. To attach this unit to another type of wall, consult with your local hardware store.

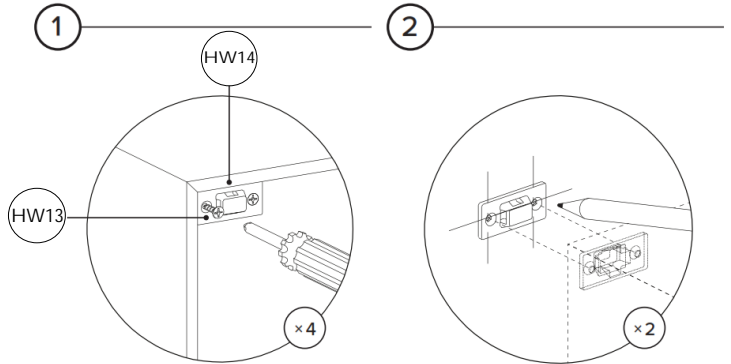

Attach pair of brackets to "Top Panel" of the unit. Note there are no existing pilot holes on the product.

Mark on wall where second pair of brackets should be placed.

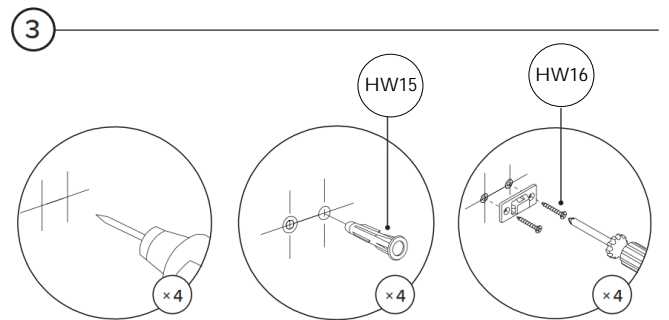



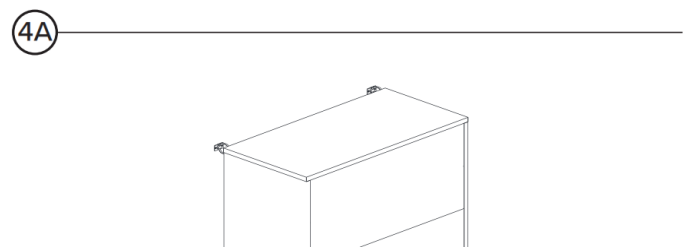

Drill holes in wall using 8mm / 5/16" drill bit.

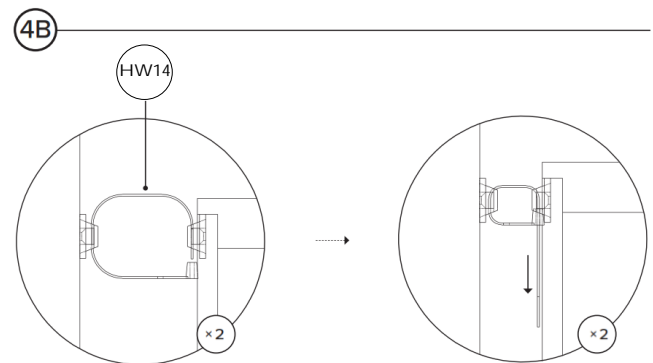

Align brackets on unit with brackets on wall.



Pull strap down until it snap-locks.

ANTI-TIP RESTRAINT PACK			
ID	DESCRIPTION		QTY
HW14	BRACKET		4
HW13	M6 × 15MM SCREW		4
HW15	M8 × 35MM		4
HW16	M10 × 50MM SCREW		4
HW14	STRAP		2