

ASSEMBLY INSTRUCTION

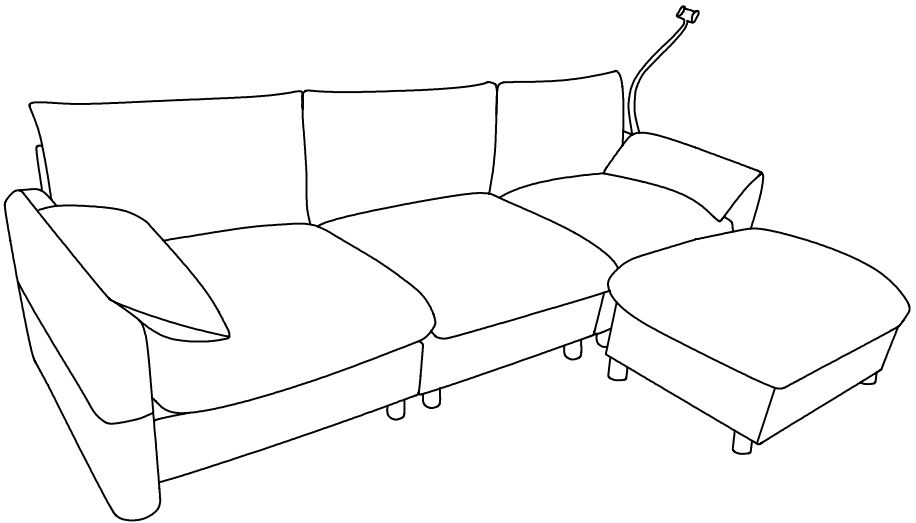

Sets often ship in multiple boxes and delivery date may vary.

CUSTOMER SERVICE

**Questions, Missing parts, Assembly help?
No need to return the product, we will gladly help and ship
your replacement parts free of charge.**

PRE-ASSEMBLY INFORMATION

Please read this manual carefully before beginning assembly of this product. Keep this manual for future reference.

NOTICE

1. Please assemble it AFTER all boxes are received.
2. Please do not throw away any of the packages or the instruction until the sofa is fully assembled.
3. Please keep children away from the plastic bags or any small pieces of stuff.
4. Some key parts of our product may be stored and hidden inside of other parts. Please open any zippered or hook & loop storage compartments to take out all parts.
5. Please do not open the compressed packages until your sofa frame is completely assembled.
6. As the cushions are all vacuum compressed, there will be some wrinkles. Please give them up to 72 hours to reach its original size and the wrinkles will basically disappear.
7. DO NOT INSTALL THE SCREWS ALL THE WAY IN THE BEGINNING. Place each screw into their proper hole and use your hand to twist the screw halfway. Twist all the screws in halfway to ensure the holes will match up properly and the product is level on the ground. When everything seems fitted, then tighten the screws.
8. Do not over tighten screws and bolts to avoid stripping.



2 adults recommended



Takes about 1.5 Hours to assemble







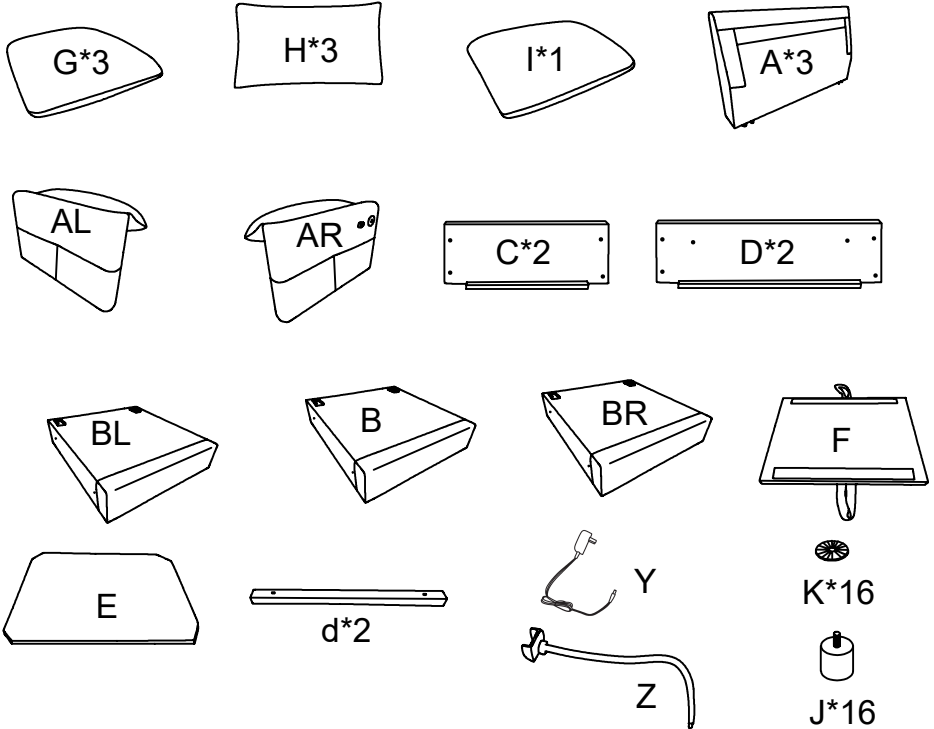

Weight capacity of each seat: 330LBS

COMPONENTS



HARDWARE

NO	DESCRIPTION	SKETCH	QTY
①	Screws 6*30mm		8
②	Washers		8
③	Leg irons		4
④	Screws 6*15mm		16
⑤	Screws 6*40mm		4
⑥	Wrench		1

COMPONENTS

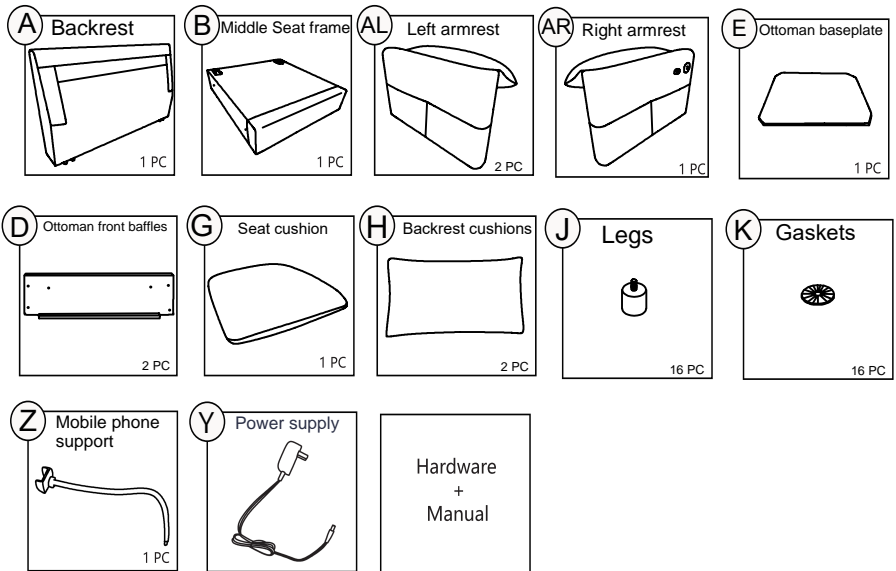
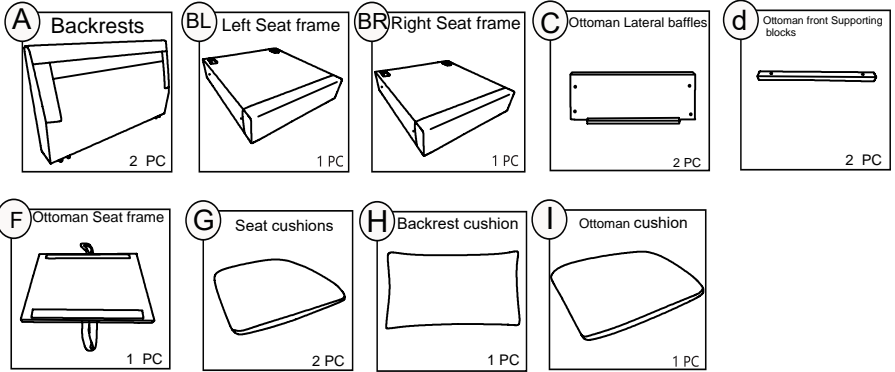

ASSEMBLY STEPS

STEP 1 Take out all the parts stored or hidden inside

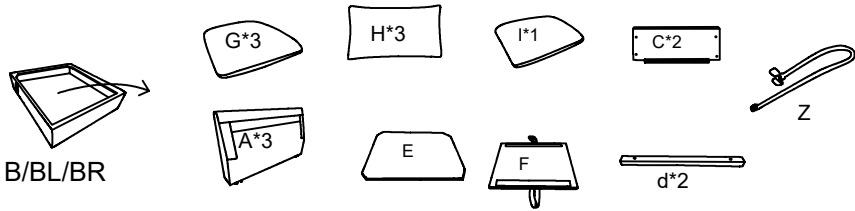

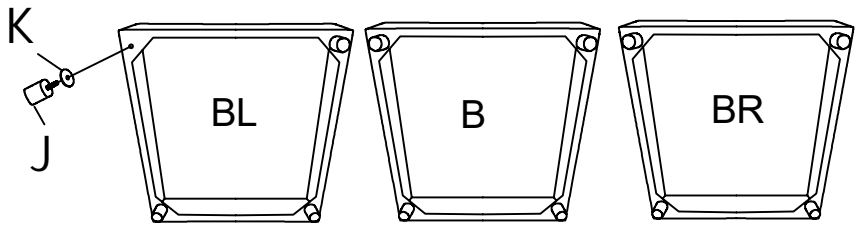
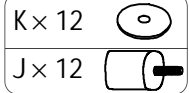

STEP 2 Attach legs (J) and Gaskets (K) to the seats

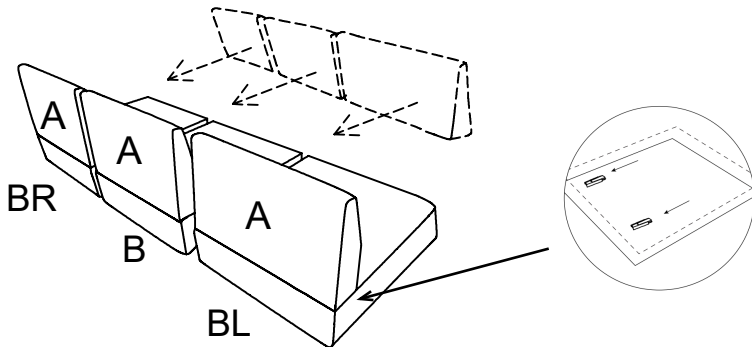

STEP 3 Link the backrests (A) and seat frames (BL/B/BR) using inserts.



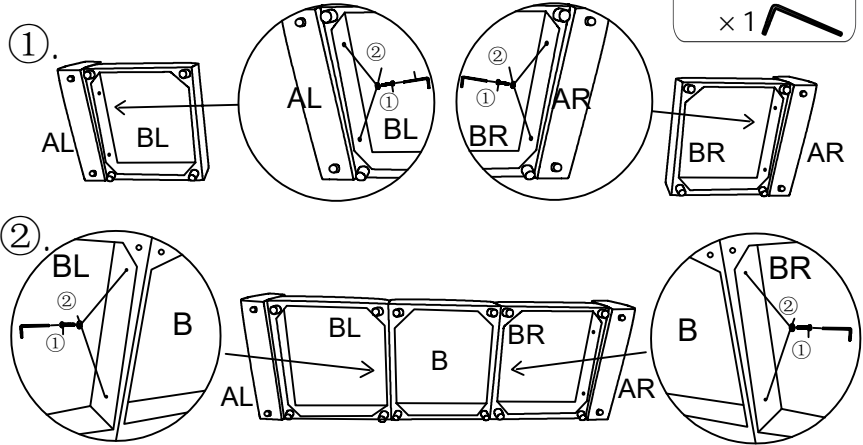

STEP 4 Install Left seat frame (BL) on Middle Seat frame (B) and Left armrest (AL) with Screws 6*30mm① and washers② by Wrench .
 Install Right seat frame (BR) on Middle Seat frame (B) and Right armrest (AR) with Screws 6*30mm① and washers② by Wrench .

- ① × 8 
- ② × 8 
- × 1 



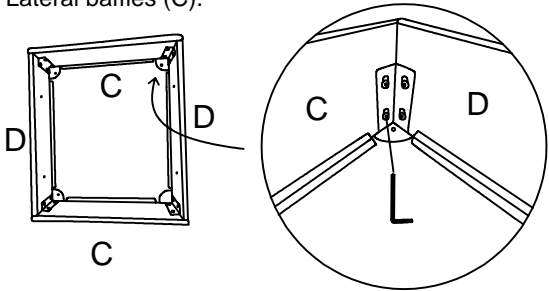

STEP 5 Use Metal screws 6*15mm ④ to link Legs irons ③ to Ottoman front baffles (D) and Ottoman Lateral baffles (C).

- ④ × 16 
- ③ × 4 
- × 1 



STEP 6 Attach legs (J) and Gaskets (K) to the Ottoman seat frame.

- K × 4 
- J × 4 

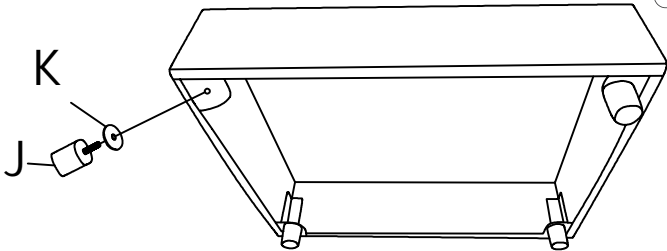

STEP 7

1. Place Ottoman baseplate (E) in the installed Ottoman seat frame.

2. Use Screws 6*40mm to link Ottoman front Supporting blocks (d) to Ottoman front baffles (D) Tighten the screws with a wrench

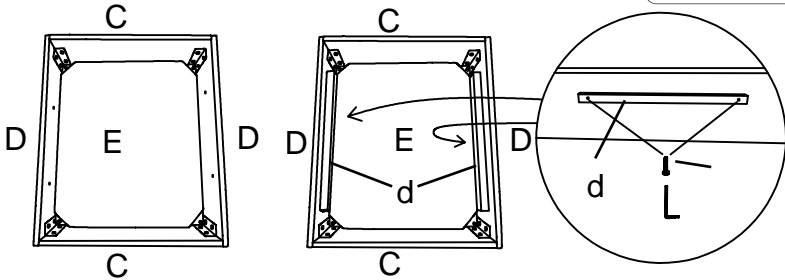
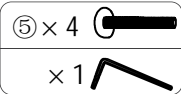
**STEP 8**

1. First, remove the screw cap that comes with part Mobile phone support (Z), and then insert the bracket into the handrail and screw the cap back on.

2. Link power supply (Y)

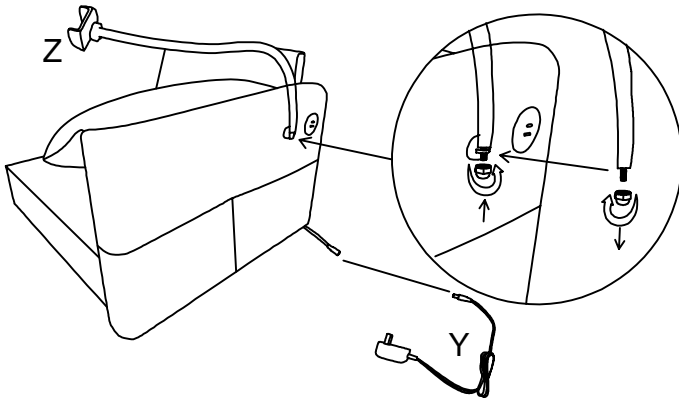
**STEP 9**

Open the vacuum bag and take the Backrest cushions(H), Seat cushions/ OttomanSeat cushion(G/I) out. To restore the original shape, follow the steps below.

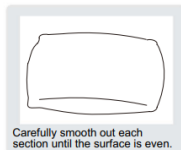

After packing up, place them in somewhere dry and venslated. After about 72-96 hours. It can be restored to the best use condition.

STEP 10

Put the cushions (G/H/I) on the sofa

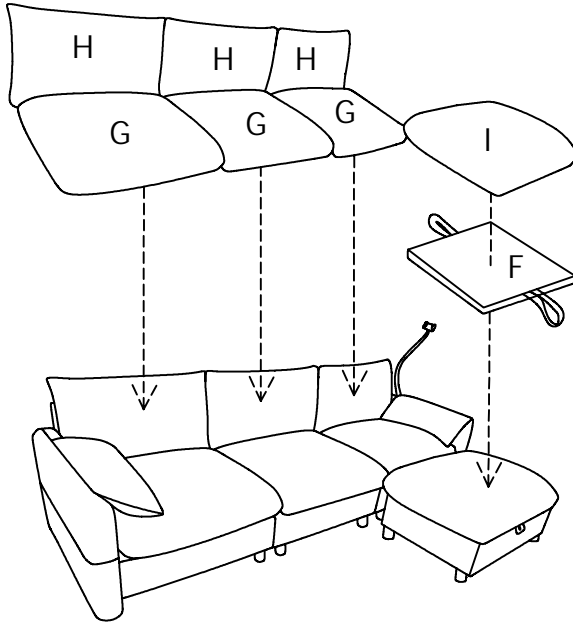

STEP 11 Complete

