

INSTRUCTION MANUAL ENCLOSED

ATTENTION

**IF YOU HAVE ANY PROBLEMS OR QUESTIONS, EMAIL OR CALL
CUSTOMER SERVICE BEFORE YOU RETURN THIS PRODUCT TO THE
STORE WHERE IT WAS PURCHASED.**

****When emailing Customer Service, please include your **Order Number** and **platform of purchase** in the email subject for quicker assistance.**

INSTRUCTION MANUAL ENCLOSED

3PCS WICKER QUEEN CHAIR SET

3PCS WICKER QUEEN CHAIR SET ASSEMBLY INSTRUCTION

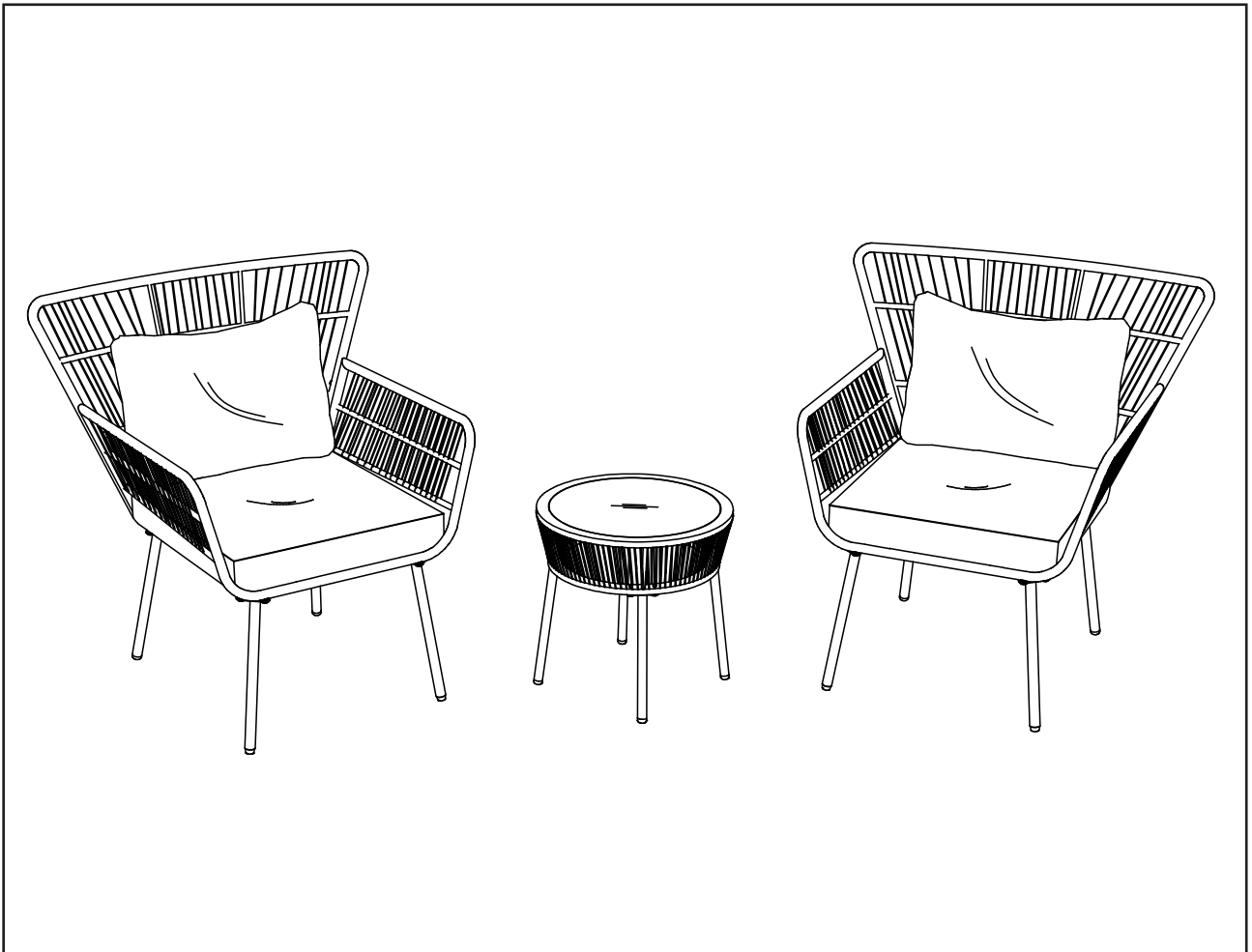

PARTS LIST











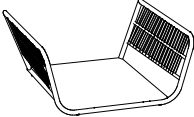

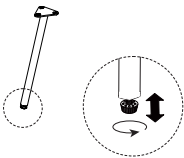
| Part | Description | Quantity |
|------|-------------|----------|
|------|-------------|----------|

PARTS

| | | |
|---|-------------------|---|
| 1 | Chair seat | 2 |
| 2 | Chair backrest | 2 |
| 3 | Back chair legs | 4 |
| 4 | Front chair legs | 4 |
| 5 | Chair cushion | 2 |
| 6 | Pillow | 2 |
| 7 | Round table frame | 1 |
| 8 | Table legs | 4 |
| 9 | Glass tabletop | 1 |

HARDWARE

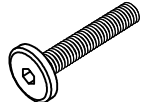
| | | |
|---|-------------------|----|
| A | Bolt M6x20 mm | 32 |
| B | Bolt M6x45 mm | 10 |
| C | Washer Ø6x14x1 mm | 42 |
| D | Allen key 4x98 mm | 2 |

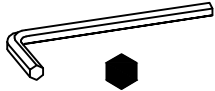
| | | | |
|--|---|--|--|
| 1  x2 | 2  x2 | 3  x4 | 4  x4 |
| 5  x2 | 6  x2 | 7  x1 | 8  x4 |
| 9  x1 | A  M6x20 mm x32 | B  M6x45 mm x10 | C  Ø6xØ14x1 mm x42 |
| D  x2 4 mm | | | |

PLEASE READ AND FOLLOW ALL SAFETY TIPS

GETTING STARTED

1. Before assembly, CAREFULLY use scissors or utility knife to cut and unwrap all parts. Make sure you do not discard the hardware.
2. Make sure that you have all the parts listed. If you are missing any parts, please email us. Please identify the parts you need and model number. Make sure to include your name and address.
3. Please include your **Order Number** and **platform of purchase** in the email subject, and one of our customer service representative will get back to you.

Warm Tips:

1. The plastic covers on some metal parts are just for product protection. Please remove it before assembly.
2. Please follow the sequence of AI during assembly.
3. Do not tighten the screws until all of them are in right positions.

1. Locate 2 back chair legs (3), 2 front chair legs (4) to the chair seat (1) by the pre-drilled threads. Use Allen Key (D) to tighten Bolts (A) and washers (C). Note: only tighten 80% (Photo 1).

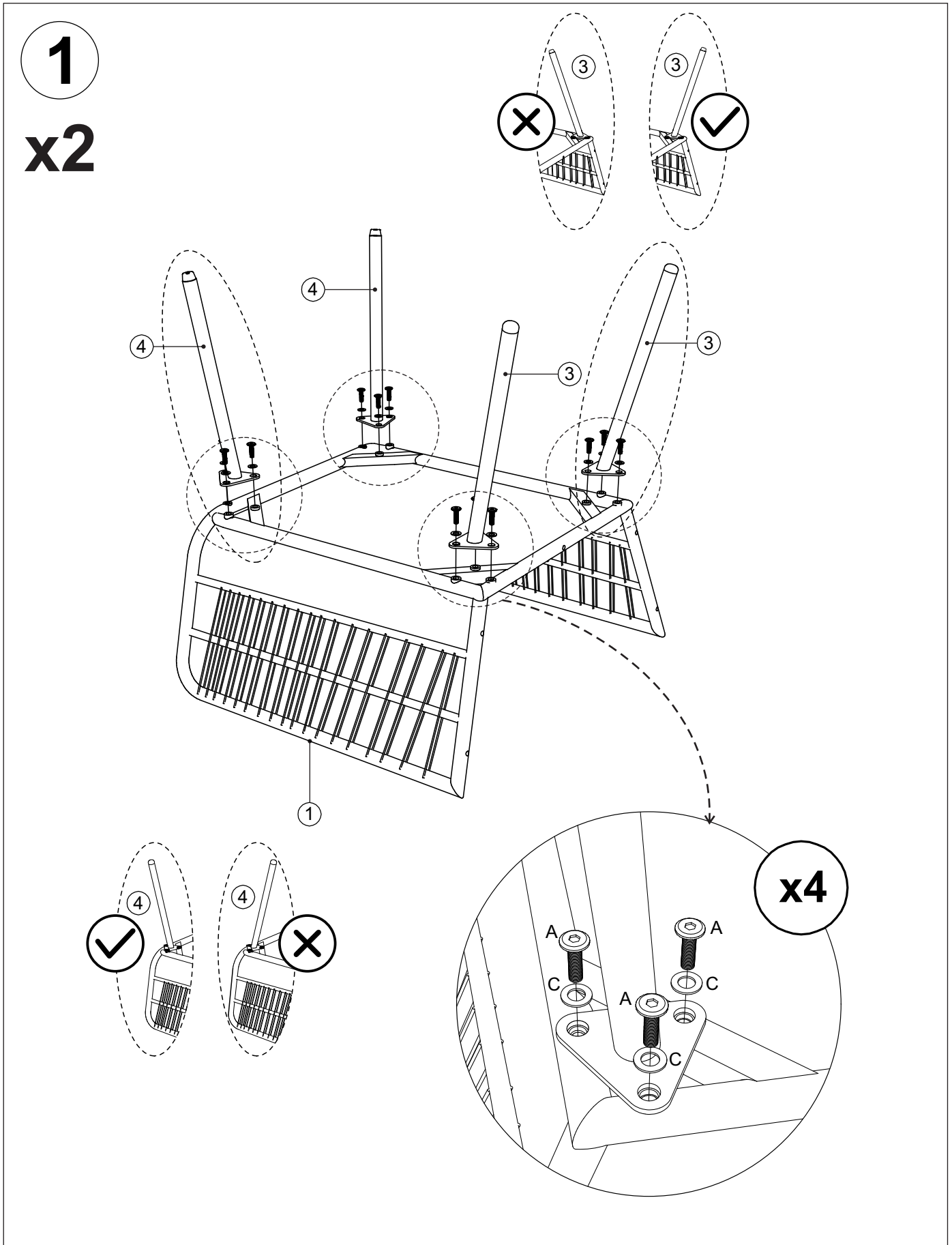

2. Locate chair backrest (2) to 1 chair seat (1) by the pre-drilled threads.
Use Allen Key (D) to tighten Bolts (B) and Washers (C).
Note: only tighten 80% (Photo 2).

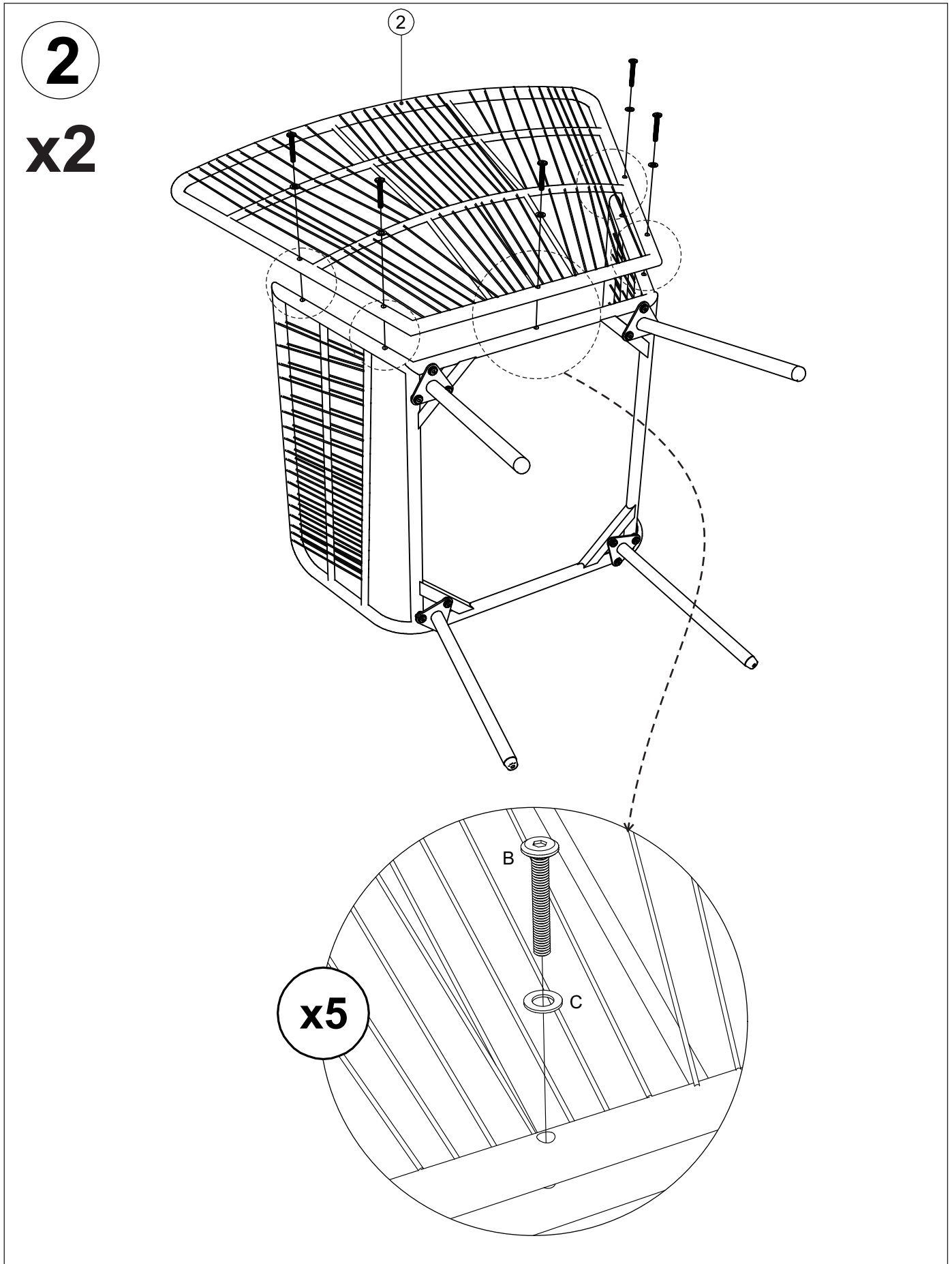

3. Use Allen Key (D) to tighten all Bolts 100% (Photo 3).



4. Place 1 chair cushion (5) on the top chair seat, and then place 1 pillows (6) above it (Photo 4).
Note: Adjust the leveling feet under the chair by turning them until the chair is balanced on the uneven floor (Photo 4).

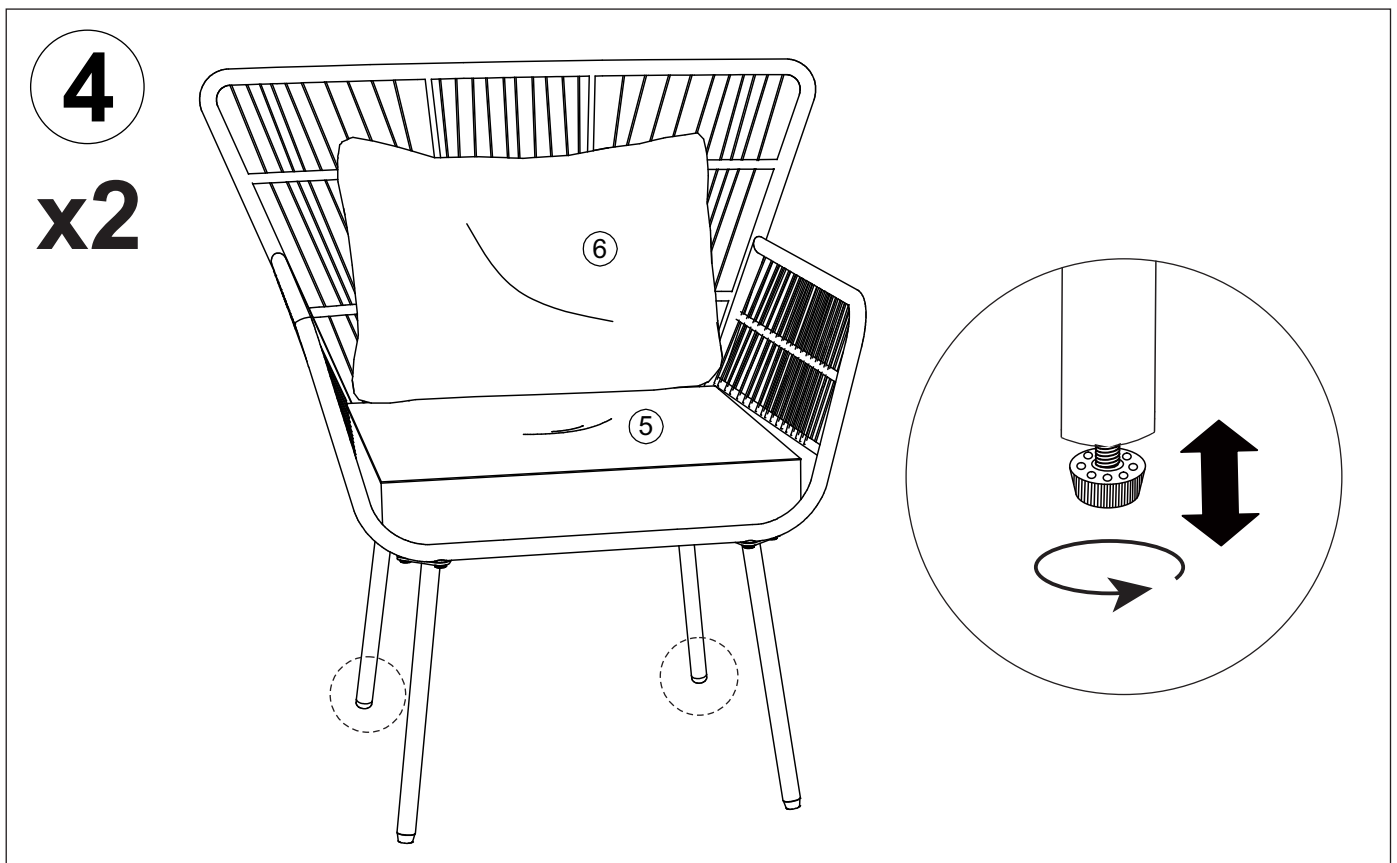

5. Locate 4 table legs (8) to the round table frame (7) by the pre-drilled threads.
Use Allen Key (D) to tighten Bolts (A) and Washers (C).
Note: only tighten 80% (Photo 5).

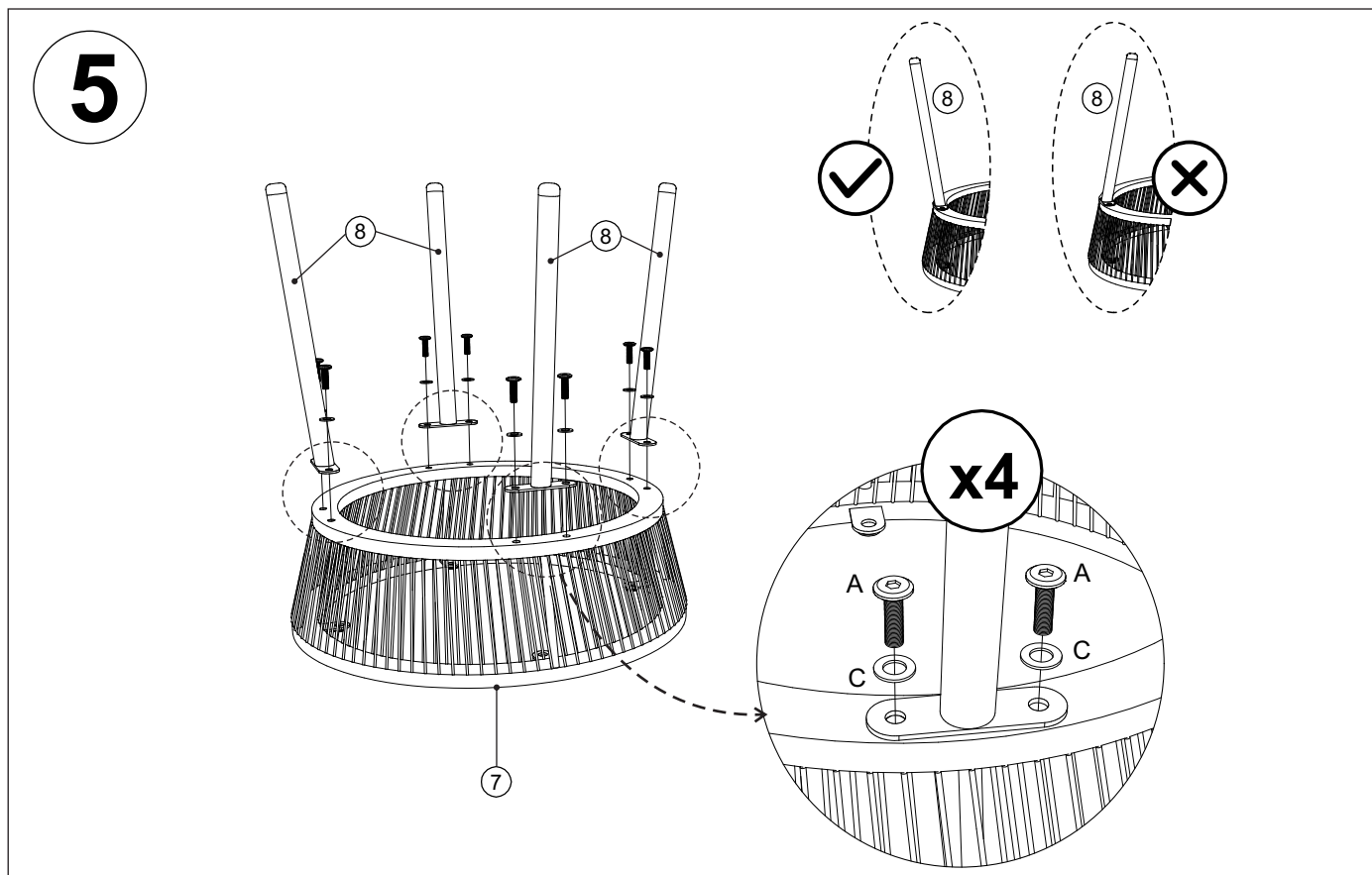

6. Use Allen Key (D) to tighten all Bolts 100%.
Place 1 glass tabletop (9) above round table frame (7).
Note: Adjust the leveling feet under the table by turning them until the table is balanced on the uneven floor (Photo 6).

