

TV STAND

Assembly Instructions - Please keep for future reference

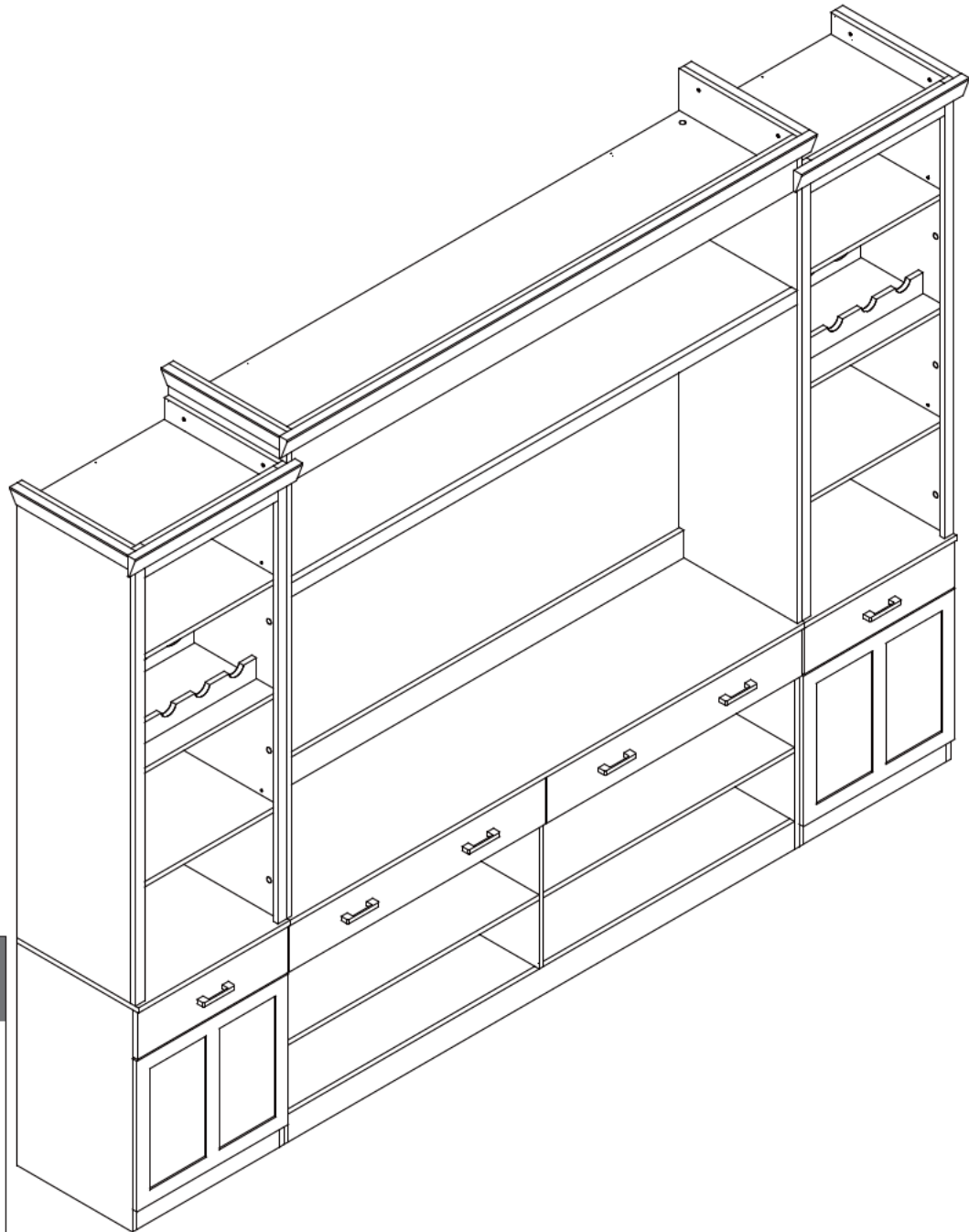

Dimensions

Width- 106.3inch

Depth-15.75inch

Height-80.51inch

Important – Please read these instructions fully before starting assembly



Safety and Care Advice

Important – Please read these instructions fully before starting assembly

- Check you have all the components and tools listed on the following pages.
- Remove all fittings from the plastic bags and separate them into their groups.
- Keep children and animals away from the work area, small parts could choke if swallowed.
- Make sure you have enough space to layout the parts before starting.

- During assembly do not stand or put weight on the product, this could cause damage.
- Assemble the item as close to its final position (in the same room) as possible.
- Assemble on a soft level surface to avoid damaging the unit or your floor.
- Parts of the assembly will be easier with 2 people.



- To reduce the likelihood of damaging your product please ensure that your power drill is set on a low torque setting.

Care and maintenance

- Only clean using a damp cloth and mild detergent, do not use bleach or abrasive cleaners.
- From time to time check that there are no loose screws on this unit.
- This product should not be discarded with household waste. Take to your local authority waste disposal centre.

Handy Hints

- Assemble all parts and bolts loosely during assembly, only once the product is complete should you fully tighten the bolts
- Regularly check and ensure that all bolts and fittings are tightened properly.

WARNING
In order to help prevent overturning – please follow these instructions













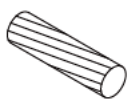

To help prevent product toppling over please follow the below steps:-

- Use the anti tip stap or wall fixing method provided (if applicable)
- Do not allow children to climb or hang on the furniture
- Do not open more than one drawer at a time
- Do not place heavy items in the top drawers
- Do not place heavy items on top of the furniture, unless the furniture has been designed for this purpose

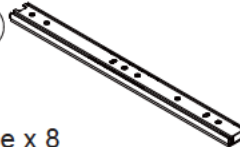
Components - Fittings

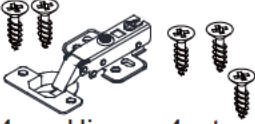
Please check you have all the panels listed below

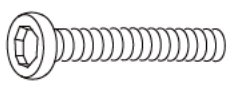
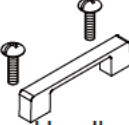
Note: The quantities below are the correct amount to complete the assembly. In some cases more fittings may be supplied than are required

<p>(A) </p> <p>Cam Bolt x 135+2</p>	<p>(B) </p> <p>6*30mm Dowel x 134+2</p>	<p>(C) </p> <p>Cam lock x 135+2</p>	<p>(D) </p> <p>4*30mm Screw x 35+2</p>
<p>(E) </p> <p>Rebound device x 2set</p>	<p>(F) </p> <p>4*40mm Screw x 12+1</p>	<p>(G) </p> <p>4*20mm Screw x 24+2</p>	<p>(H) </p> <p>6*20mm Dowel x 15+1</p>
<p>(I) </p> <p>2.6*10mm Screw x 22+2</p>	<p>(J) </p> <p>3*12mm Screw x 32+2</p>	<p>(K) </p> <p>Slide x 8</p>	<p>(L) </p> <p>Shelf support pin x 16+1</p>
<p>(M) </p> <p>3.5*14mm Hinge x 4set</p>	<p>(N) </p> <p>Allen key x 1</p>	<p>(O) </p> <p>Bracket x 5</p>	<p>(P) </p> <p>6*30mm Screw x 4</p>
<p>(Q) </p> <p>4*18mm Handle x 6set</p>	<p>(R) </p> <p>Anti-tipping Device x4</p>	<p>(S) </p> <p>Perfect fit x50</p>	

Tools required Not Included

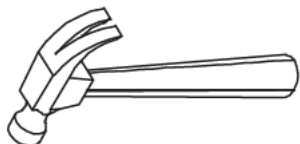
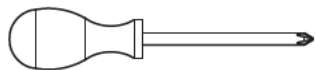
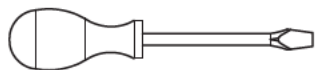

Phillips screwdriver
(medium & large)

Using Camlocks

Step 1

Connect the male camlock as directed in the assembly instructions using a screwdriver.

1

DO NOT OVER TIGHTEN.
NE PAS SERRER EXCESSIVEMENT.

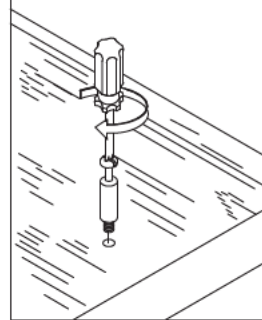

Step 2

Push the male camlock into the entry hole.

2

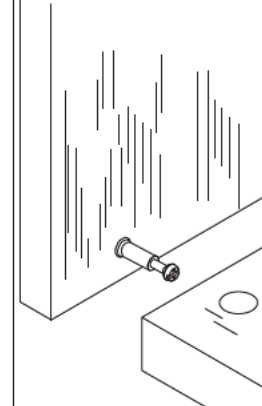

Step 3

Insert the female camlock as shown in the instruction.

Note: ensure that the arrow on the top of the camlock points towards the entry hole for the male camlock.

3

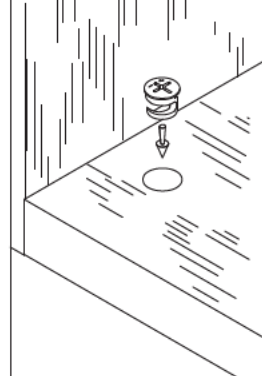

Step 4

Turn the female camlock clockwise with a screwdriver.

You should feel a click when the camlock is locked in place.



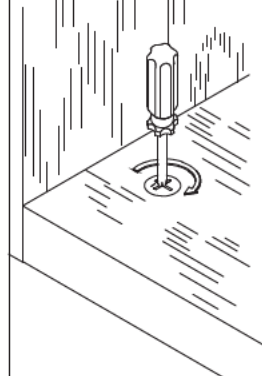

The joint is now secure.

4



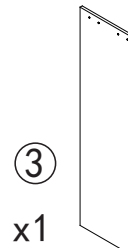
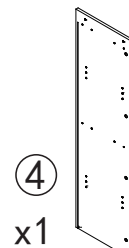
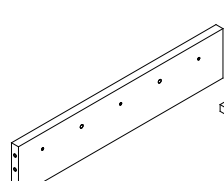
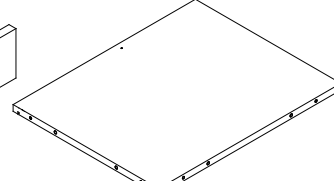
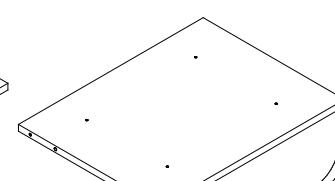
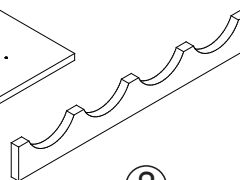
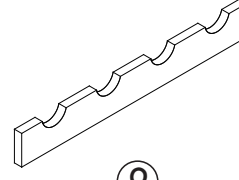
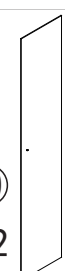
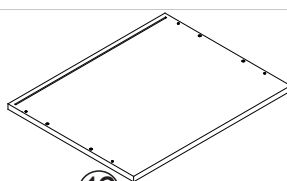
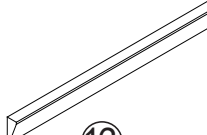
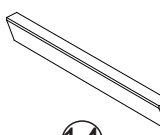
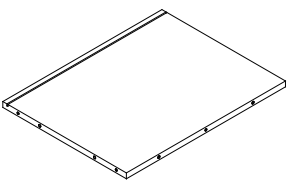
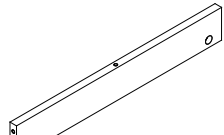
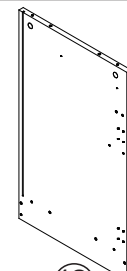

PART LIST

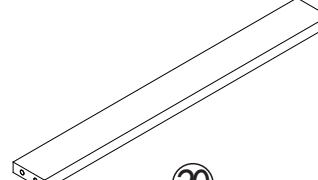
There are 3 boxes of this product.



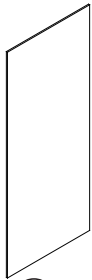

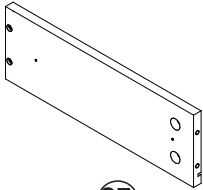
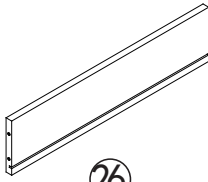
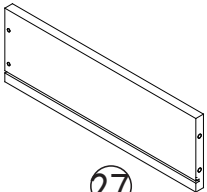
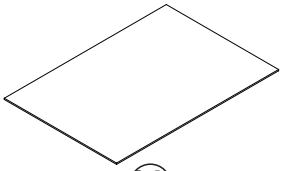
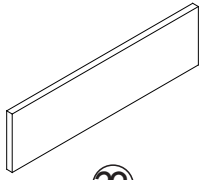
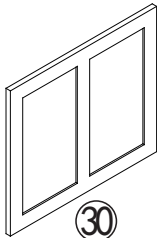
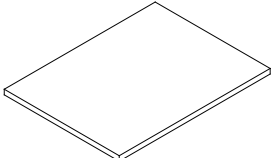
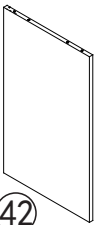
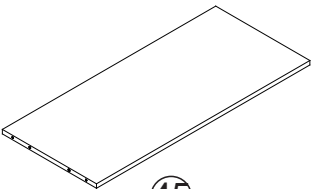
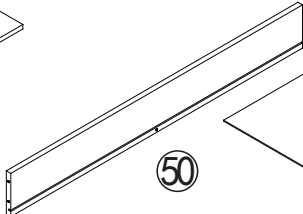
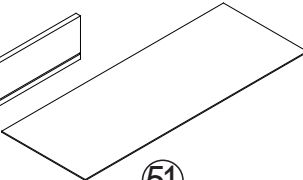
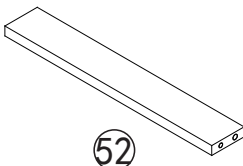
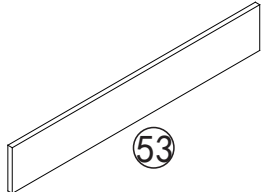
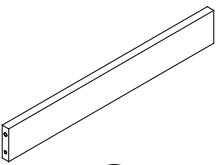

 <p>① x1</p> <p>Counter Receipt 1300x30x15mm</p>	 <p>② x1</p> <p>Counter Receipt 1300x30x15mm</p>	 <p>③ x1</p> <p>Upper Cabinet side panel 1300x375x15mm</p>	 <p>④ x1</p> <p>Upper Cabinet side panel 1300x375x15mm</p>	
 <p>⑤ x1</p> <p>Roof front section 440x92x15mm</p>	 <p>⑥ x1</p> <p>tip plate 470x375x15mm</p>	 <p>⑦ x1</p> <p>Upper Cabinet fixed laminate 470x360x15mm</p>	 <p>⑧ x1</p> <p>The wine cabinet 460x60x15mm</p>	 <p>⑨ x1</p> <p>The wine cabinet 460x60x15mm</p>
 <p>⑩ x2</p> <p>Upper Cabinet back panel 1233x240x3mm</p>	<p>⑪ x1</p> <p>Back slats</p>	 <p>⑫ x1</p> <p>kneading board 500x400x15mm</p>	 <p>⑬ x1</p> <p>Styling strip 553x60x25mm</p>	 <p>⑭ x1</p> <p>Styling strip 390x60x25mm</p>
 <p>⑮ x1</p> <p>base plate 470x365x15mm</p>	 <p>⑯ x1</p> <p>Drain 470x65x15mm</p>	 <p>⑰ x1</p> <p>Side panel of lower cabinet 635x380x15mm</p>	 <p>⑱ x1</p> <p>Side panel of lower cabinet 635x380x15mm</p>	 <p>⑳ x1</p> <p>Lower Cabinet horizontal bar 470x52x15mm</p>

PART LIST



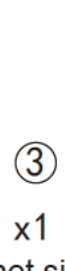
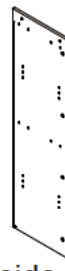
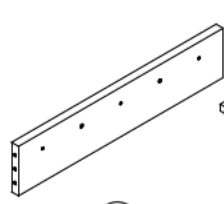
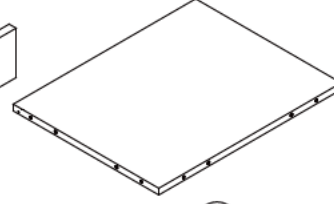
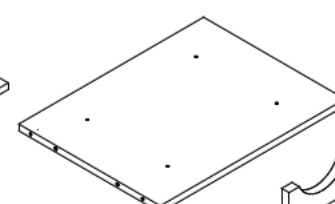
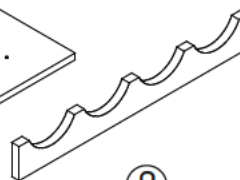

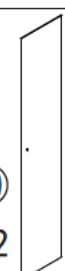
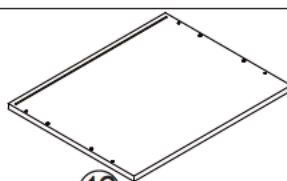
 <p>21 x2 Lower Cabinet back panel 565x240x3mm</p>	 <p>22 x1 Back slats</p>	 <p>25 x2 Drawer side panel 300x100x12mm</p>	 <p>26 x1 Back panel of drawer 420x100x12mm</p>	 <p>27 x2 Drawer side panel 300x100x12mm</p>
 <p>28 x1 Drawer back panel 430x298x3mm</p>	 <p>29 x1 Drawer Panel 497x135x15mm</p>	 <p>30 x1 door plank 500x430x15mm</p>	 <p>31 x2 Active laminate 470x358x15mm</p>	 <p>42 x1 Side panel of lower cabinet 635x380x15mm</p>
 <p>45 x1 Upper Cabinet fixed laminate 827x365x15mm</p>	 <p>50 x1 Back panel of drawer 780x100x12mm</p>	 <p>51 x1 Drawer back panel 790x298x3mm</p>	 <p>52 x1 Drawer drawers 288x45x12mm</p>	 <p>53 x1 Drawer Panel 845x135x15mm</p>
 <p>55 x1 Drain 470x80x15mm</p>				

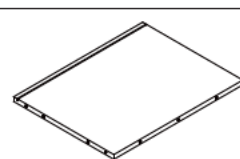
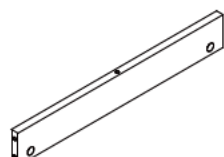
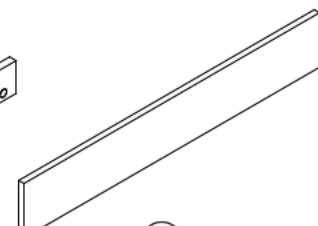
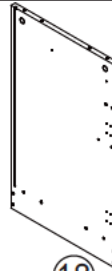
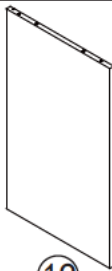
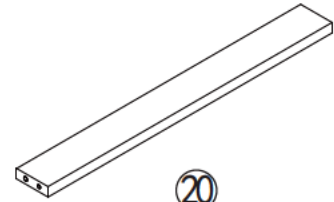
PART LIST

There are 3 boxes of this product.

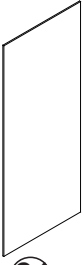

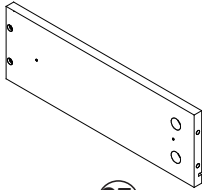
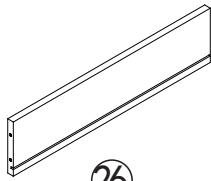
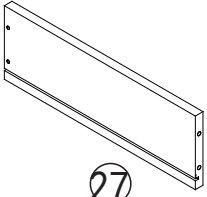
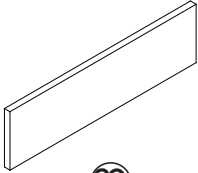
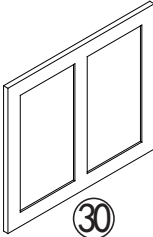
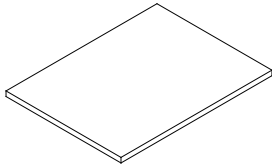
 <p>① x1</p> <p>Counter Receipt 1300x30x15mm</p>	 <p>② x1</p> <p>Counter Receipt 1300x30x15mm</p>	 <p>③ x1</p> <p>Upper Cabinet side panel 1300x375x15mm</p>	 <p>④ x1</p> <p>Upper Cabinet side panel 1300x375x15mm</p>	
 <p>⑤ x1</p> <p>Roof front section 440x92x15mm</p>	 <p>⑥ x1</p> <p>tip plate 470x375x15mm</p>	 <p>⑦ x1</p> <p>Upper Cabinet fixed laminate 470x360x15mm</p>	 <p>⑧ x1</p> <p>The wine cabinet 460x60x15mm</p>	 <p>⑨ x1</p> <p>The wine cabinet 460x60x15mm</p>
 <p>⑩ x2</p> <p>Upper Cabinet back panel 1233x240x3mm</p>	<p>⑪ x1</p> <p>Back slats</p>	 <p>⑫ x1</p> <p>kneading board 500x400x15mm</p>	 <p>⑬ x1</p> <p>Styling strip 553x60x25mm</p>	 <p>⑮ x1</p> <p>base plate 470x365x15mm</p>
 <p>⑯ x1</p> <p>Drain 470x65x15mm</p>	 <p>⑰ x1</p> <p>Drawer Panel 845x135x15mm</p>	 <p>⑱ x1</p> <p>Side panel of lower cabinet 635x380x15mm</p>	 <p>⑲ x1</p> <p>Side panel of lower cabinet 635x380x15mm</p>	 <p>⑳ x1</p> <p>Lower Cabinet horizontal bar 470x52x15mm</p>

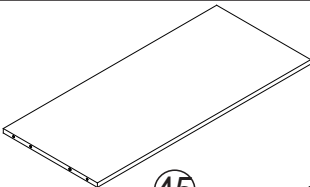
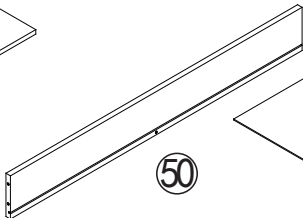
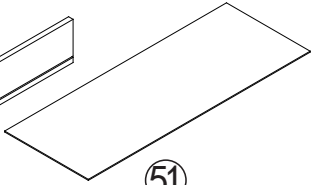
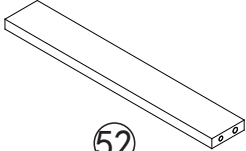
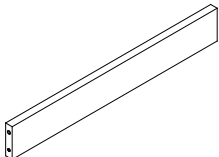
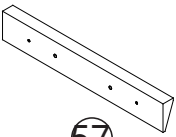
PART LIST

 <p>21 x2 Lower Cabinet back panel 565x240x3mm</p>	 <p>22 x1 Back slats</p>	 <p>25 x2 Drawer side panel 300x100x12mm</p>	 <p>26 x1 Back panel of drawer 420x100x12mm</p>	 <p>27 x2 Drawer side panel 300x100x12mm</p>
 <p>28 x1 Drawer back panel 430x298x3mm</p>	 <p>29 x1 Drawer Panel 497x135x15mm</p>	 <p>30 x1 door plank 500x430x15mm</p>	 <p>31 x2 Active laminate 470x358x15mm</p>	 <p>43 x1 Side panel of lower cabinet 635x380x15mm</p>
 <p>45 x1 Upper Cabinet fixed laminate 827x365x15mm</p>	 <p>50 x1 Back panel of drawer 780x100x12mm</p>	 <p>51 x1 Drawer back panel 790x298x3mm</p>	 <p>52 x1 Drawer drawers 288x45x12mm</p>	 <p>55 x1 Drain 470x80x15mm</p>
 <p>57 x1 Styling strip 390x60x25mm</p>				

PART LIST

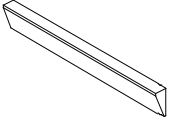
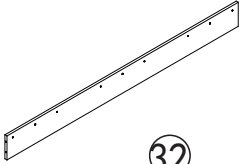
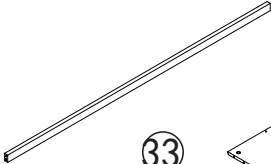
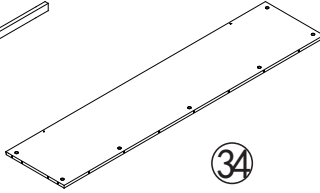
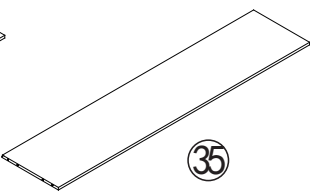
There are 3 boxes of this product.

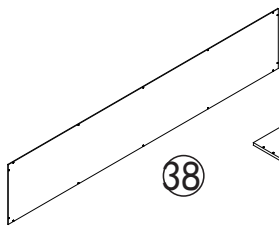
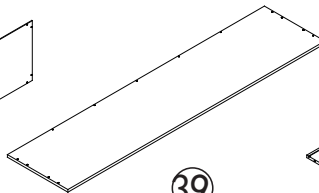
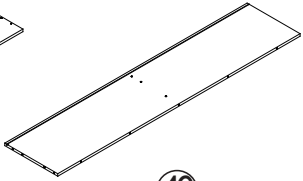
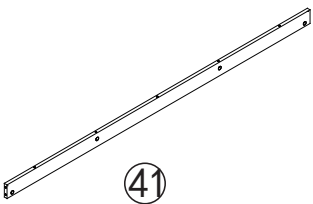
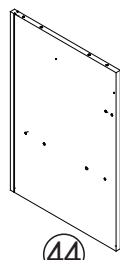
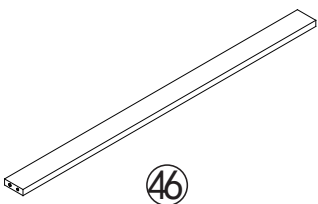
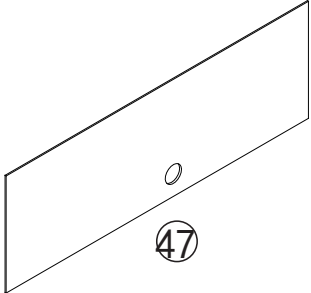
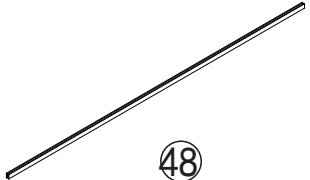
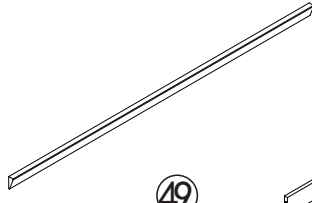
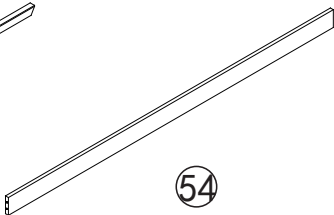
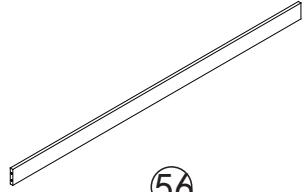
 <p>⑭ x1 Styling strip 390x60x25mm</p>	 <p>⑳ x1 Roof front section 1670x150x15mm</p>	 <p>㉑ x1 Square tube 1670x40x20mm</p>	 <p>㉒ x1 tip plate 1670x375x15mm</p>	 <p>㉓ x1 Upper Cabinet fixed laminate 1670x375x15mm</p>
 <p>㉔ x1 Upper Cabinet side panel 1390x390x15mm</p>	 <p>㉕ x1 Upper Cabinet side panel 1390x390x15mm</p>	 <p>㉖ x1 Upper Cabinet back panel 1688x323x3mm</p>	 <p>㉗ x1 kneading board 1700x400x15mm</p>	 <p>㉘ x1 base plate 1670x365x15mm</p>
 <p>㉙ x1 Drain 1670x65x15mm</p>	 <p>㉚ x1 Medium vertical plate 555x380x15mm</p>	 <p>㉛ x2 Lower Cabinet horizontal bar 827x52x15mm</p>	 <p>㉜ x4 Lower Cabinet back panel 282x375x3mm</p>	
 <p>㉝ x2 Back slats</p>	 <p>㉞ x1 Styling strip 1750x60x25mm</p>	 <p>㉟ x1 Dackspace 1670x79x15mm</p>	 <p>㊱ x1 Drain 1670x80x15mm</p>	

PART LIST

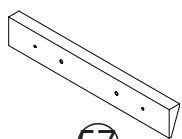

57

x1

Styling strip

390x60x25mm



Hardware kit x1

Assembly Instructions

x2

Step 1

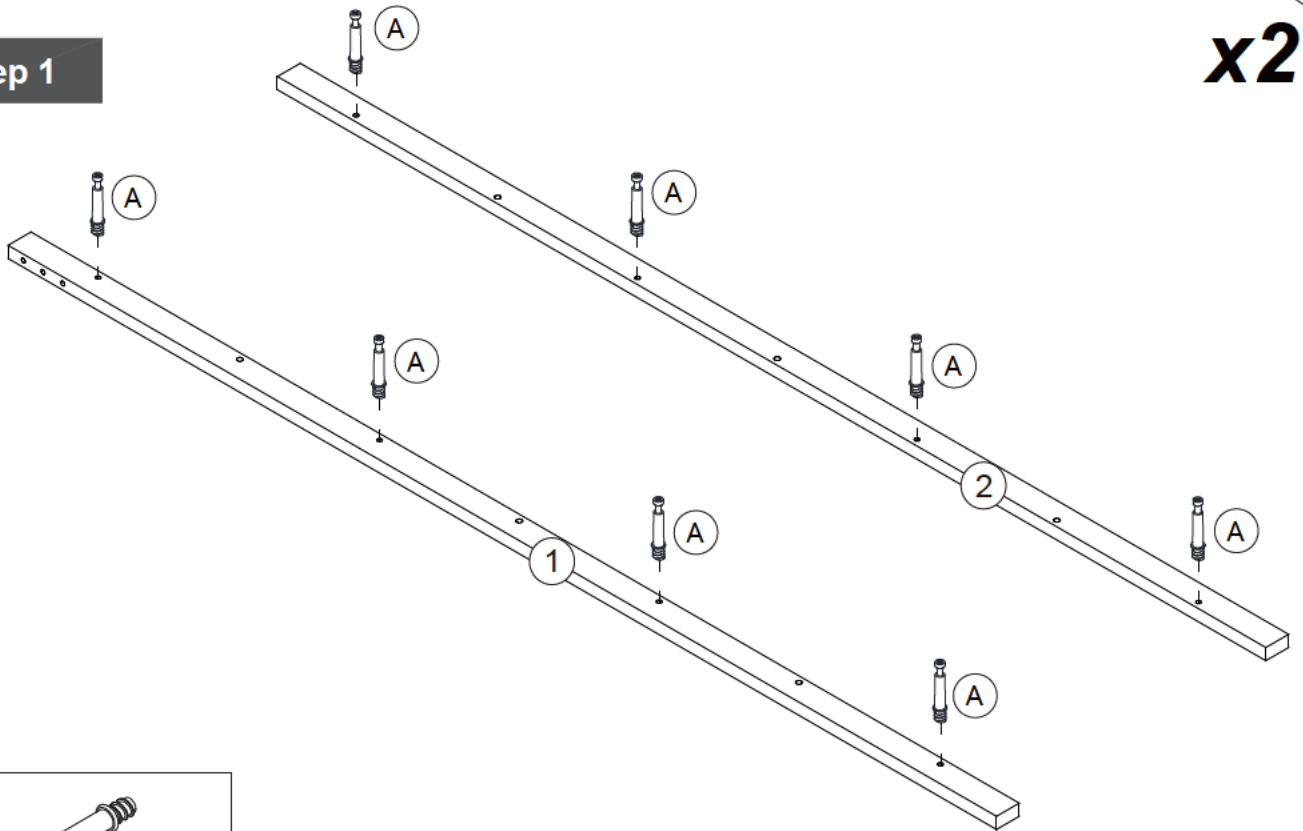

A



Cam Bolt x 16

Step 2

x2

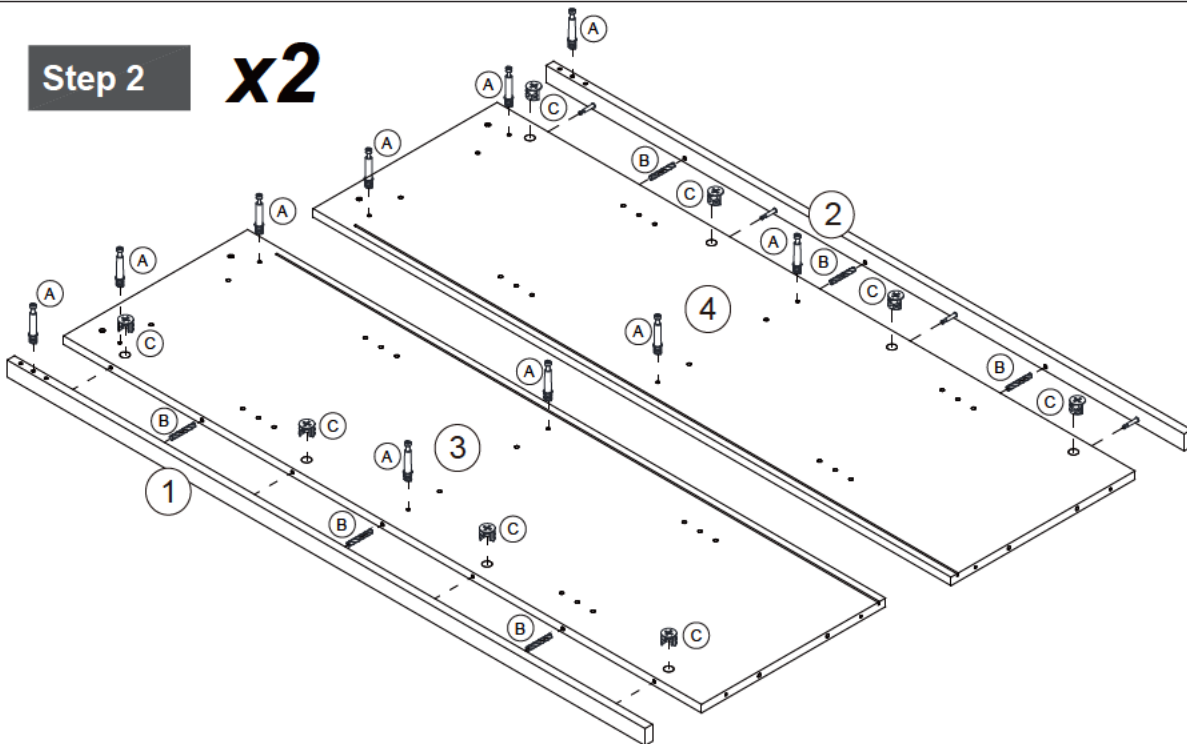

step1

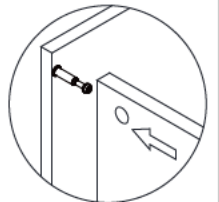

step2

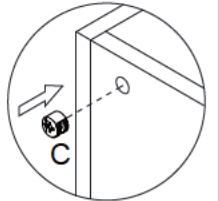

step3

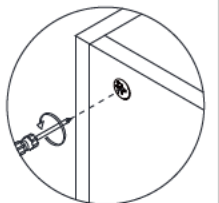

A



Cam Bolt x 20

B

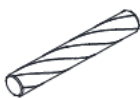

6*30mm Dowel x 12

C







Cam Bolt x 16

Assembly Instructions

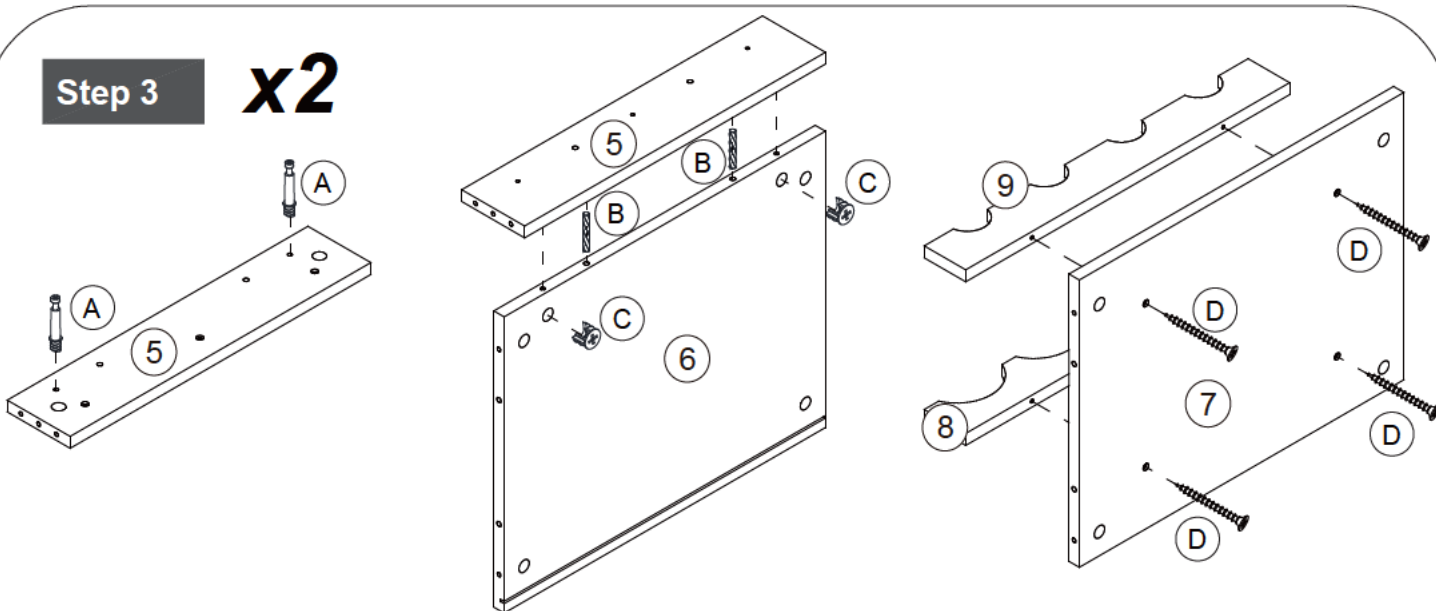
Step 3

x2

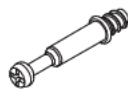

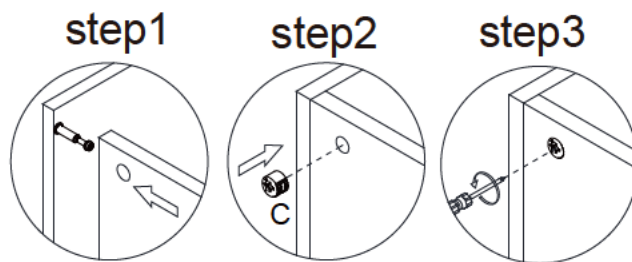

<p>(D)</p>  <p>4*30mm Screw x 8</p>	<p>(B)</p>  <p>6*30mm Dowel x 4</p>
<p>(A)</p>  <p>Cam Bolt x 4</p>	<p>(C)</p>  <p>Cam lock x 4</p>

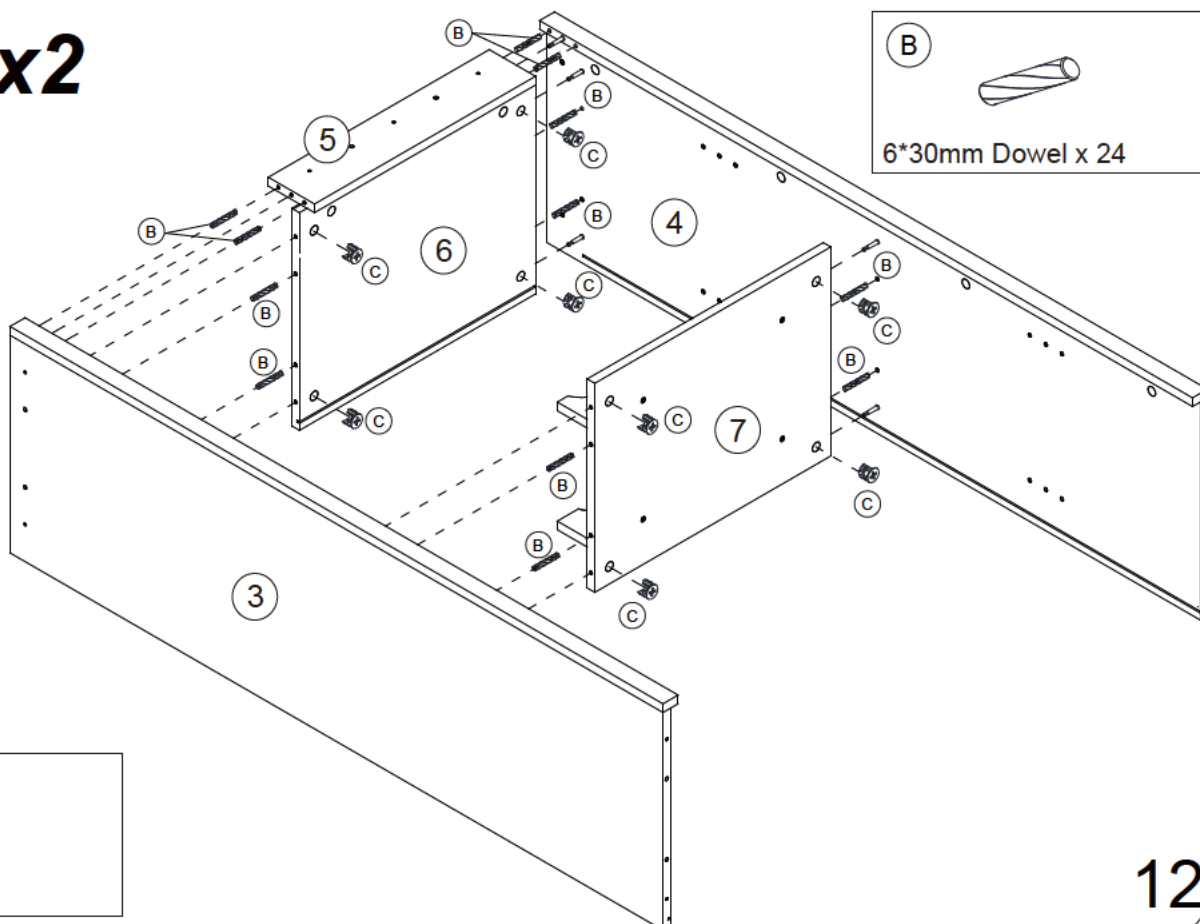

Step 4

x2



<p>(B)</p>  <p>6*30mm Dowel x 24</p>

<p>(C)</p>  <p>Cam Bolt x 16</p>

Assembly Instructions

Step 5

x2

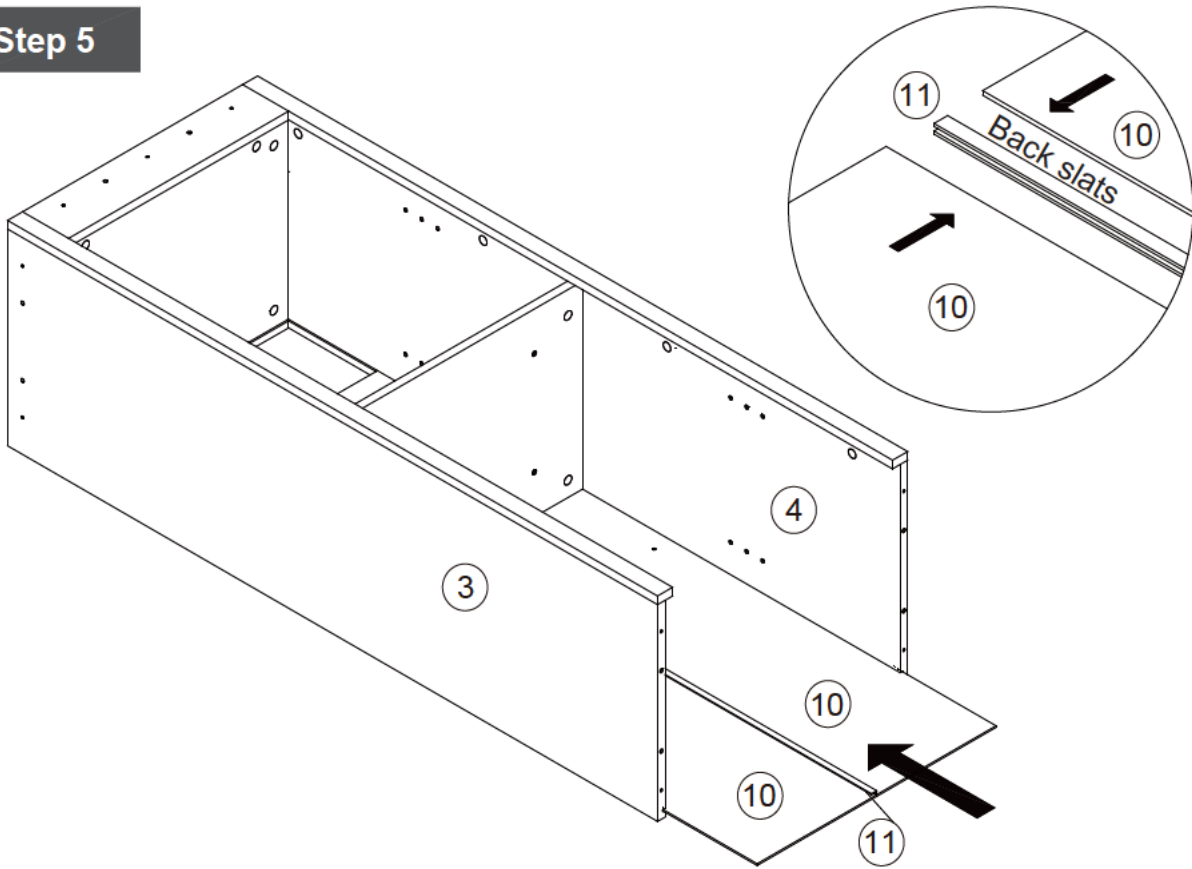

Step 6

x2

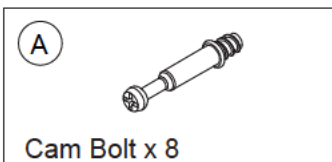
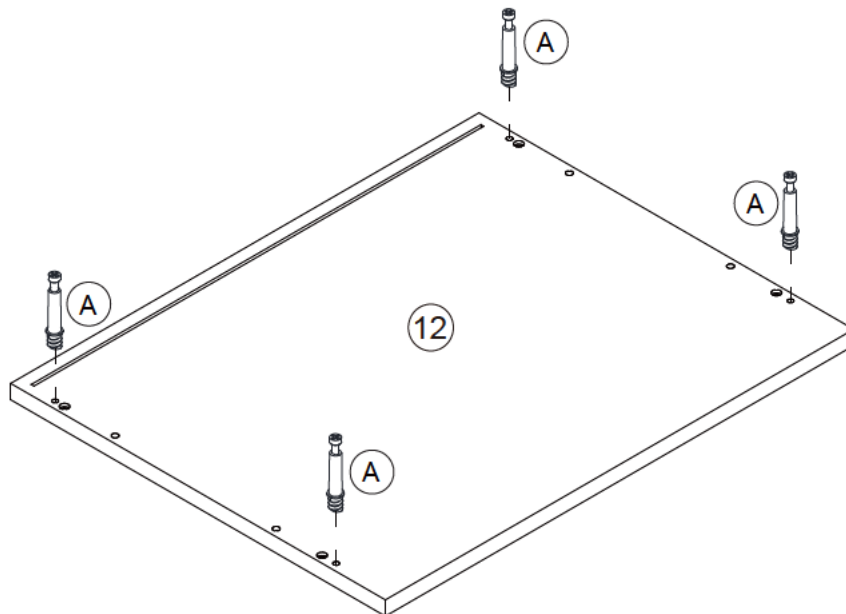

13

Assembly Instructions

x2

Step 7

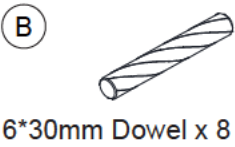
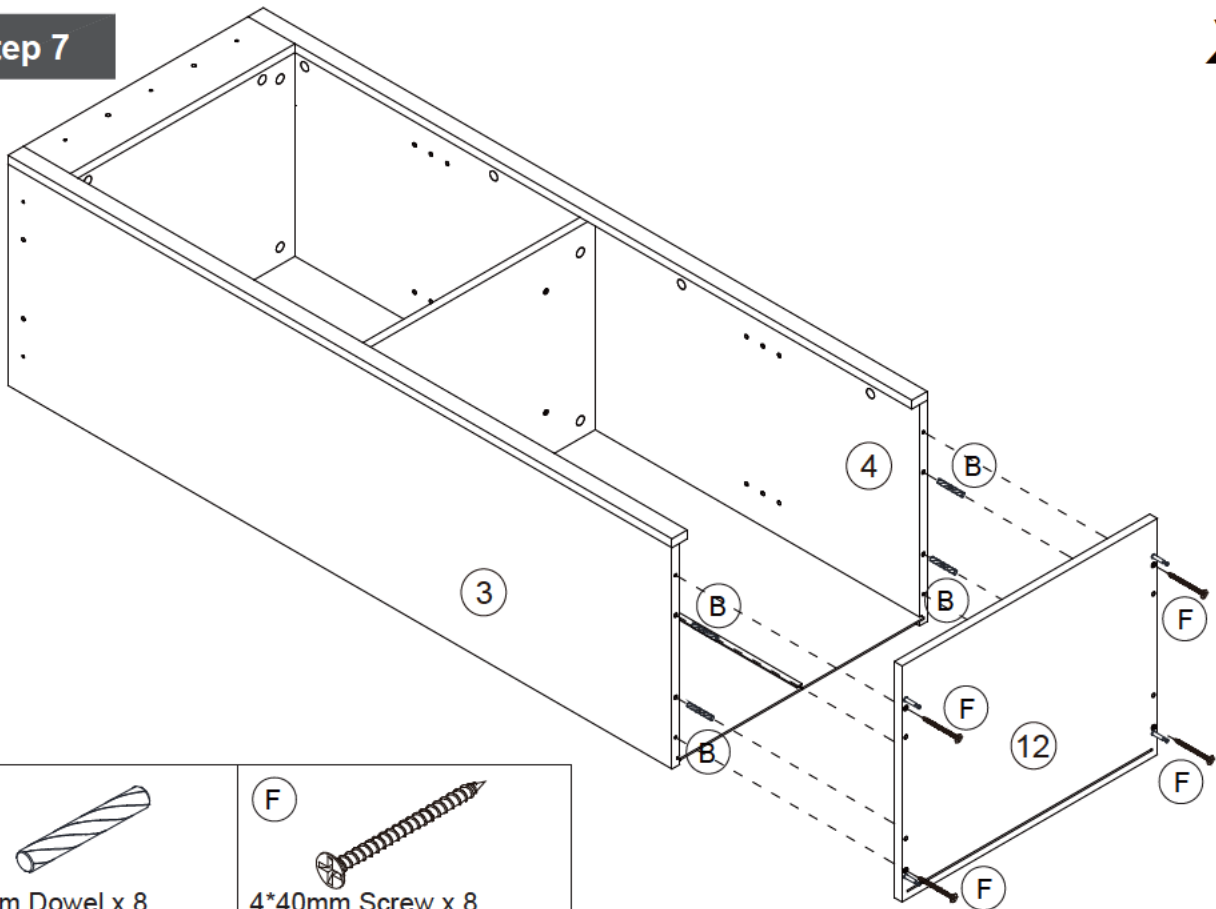

Step 8

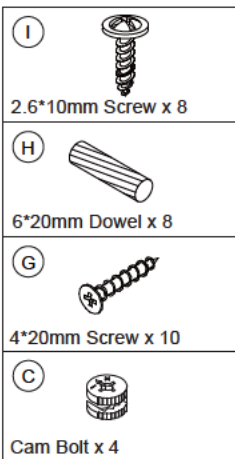
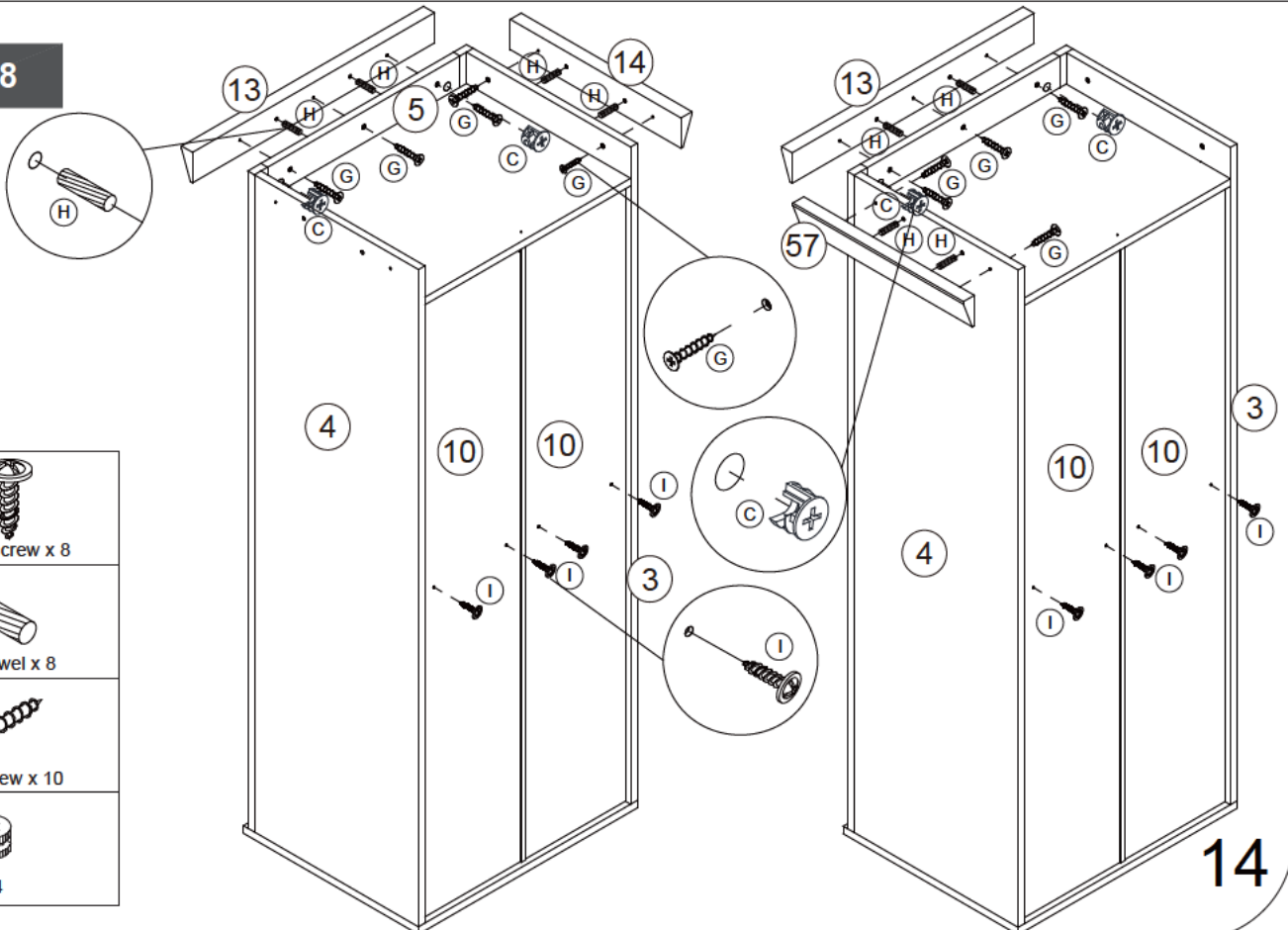

14

Assembly Instructions

Step 9

x2

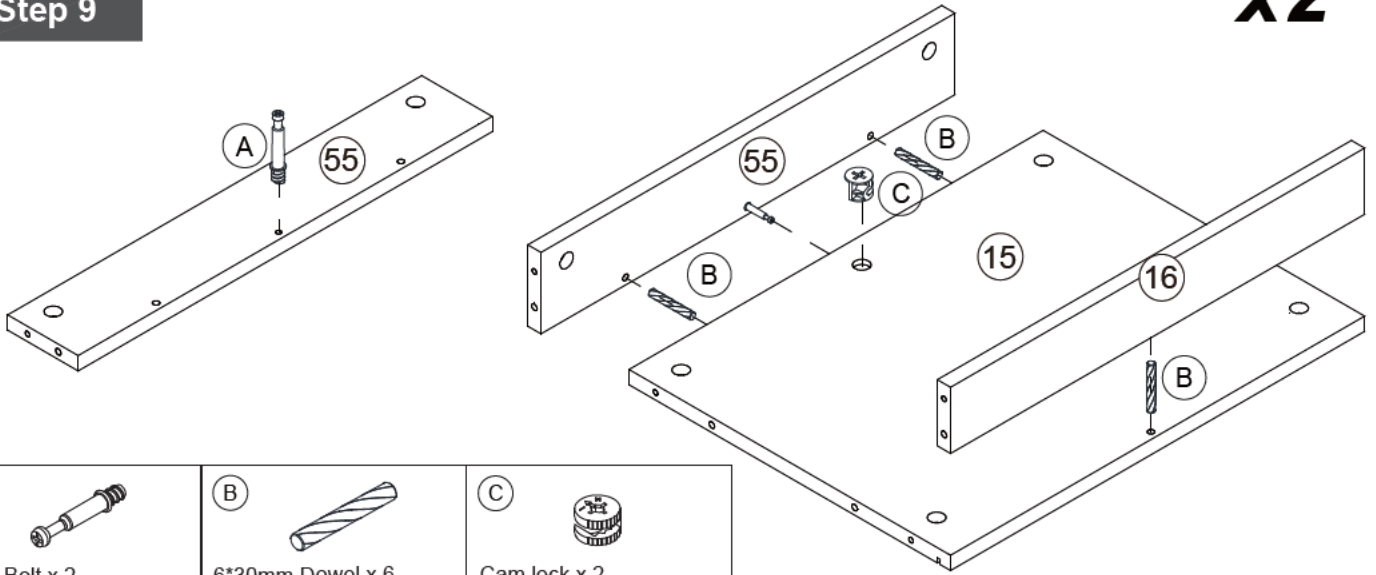

Step 10

x8

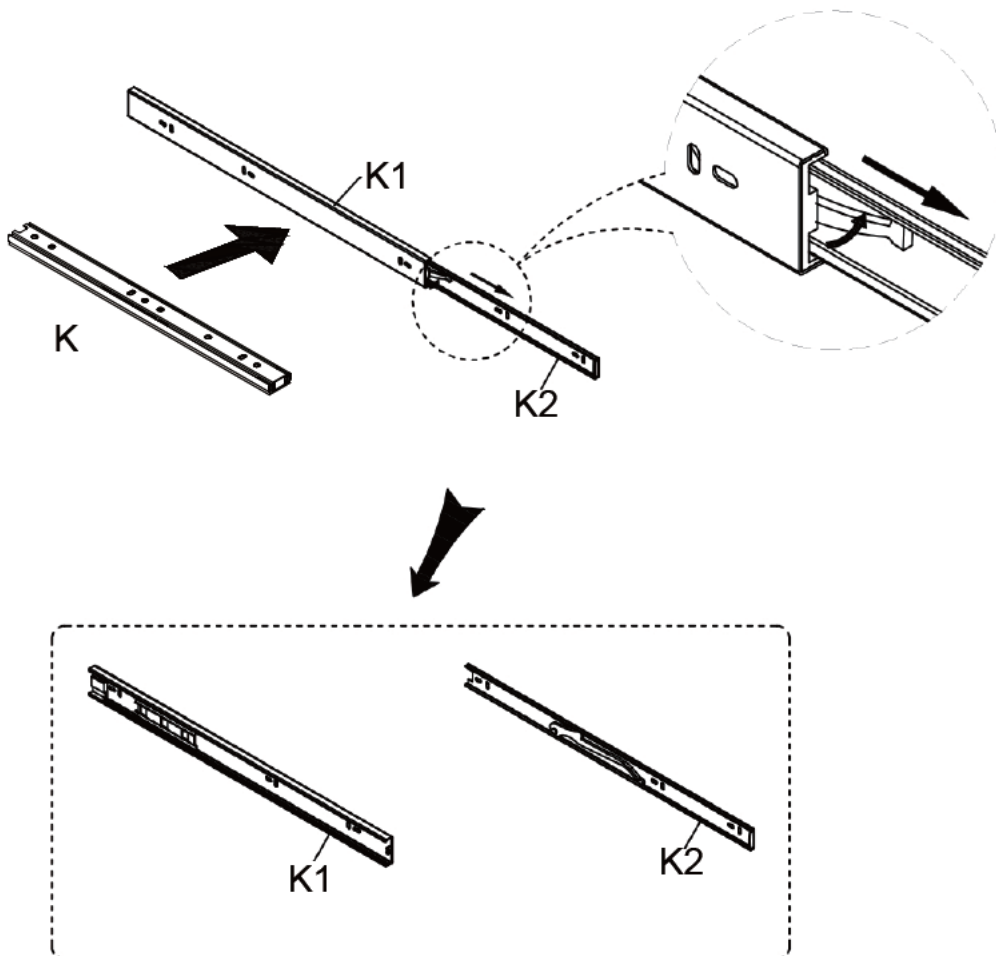

15

Assembly Instructions

Step 11

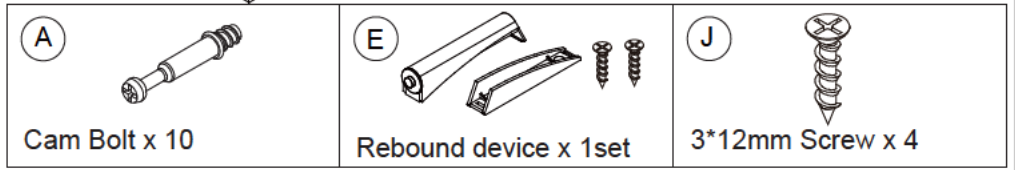
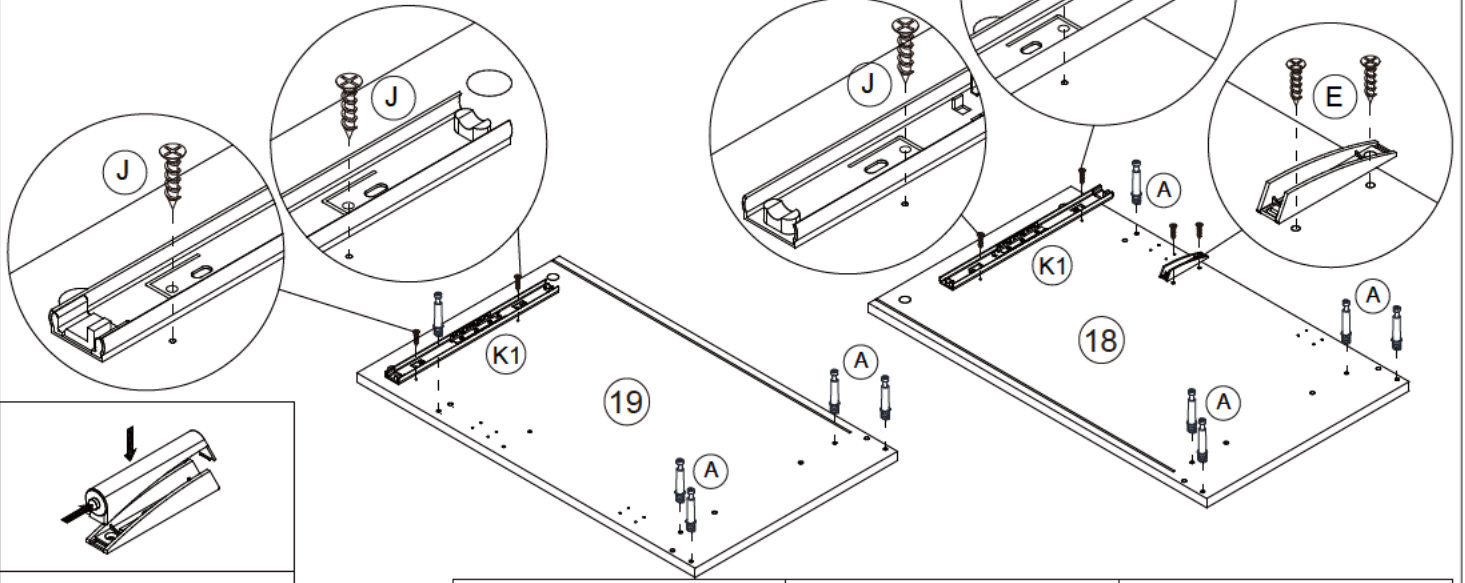
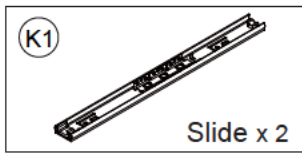

Step 12

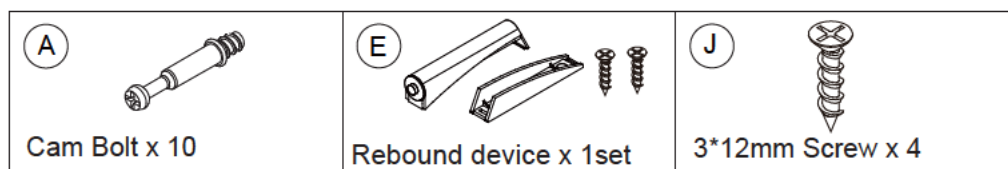
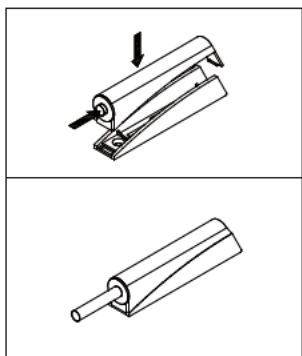
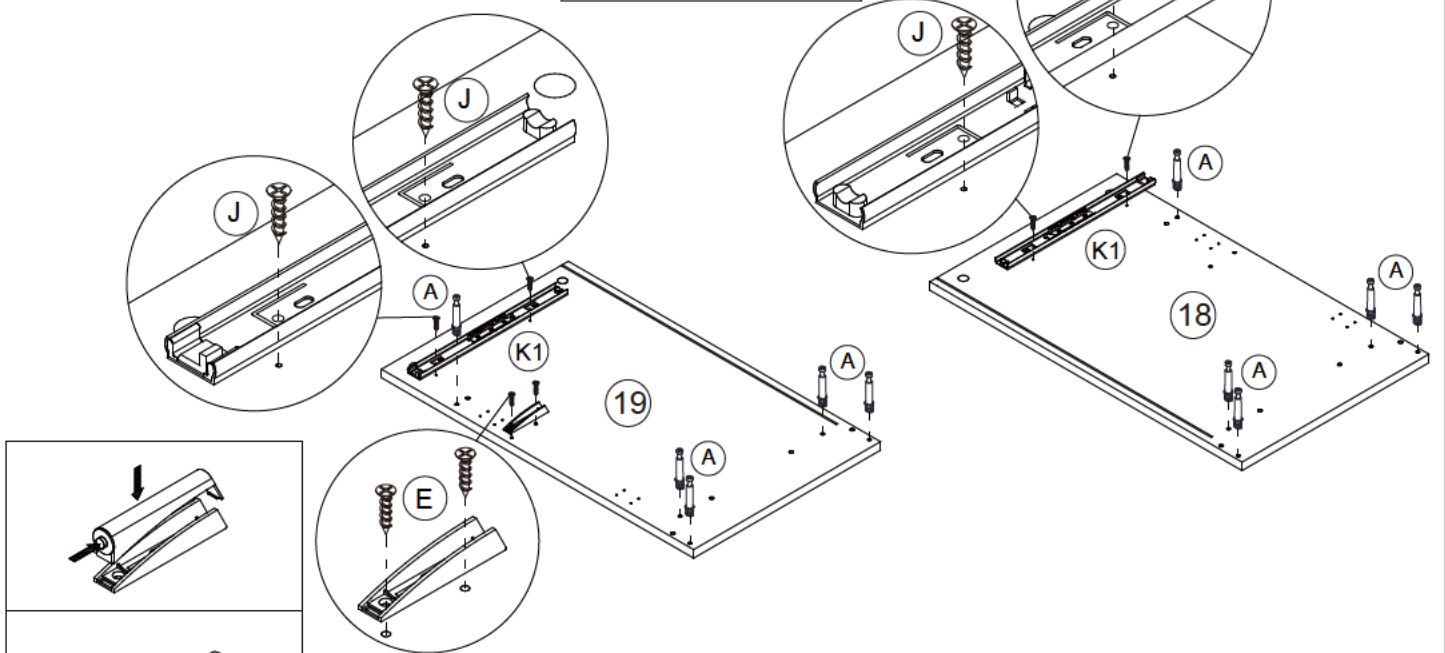
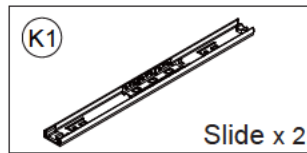

Assembly Instructions

Step 13

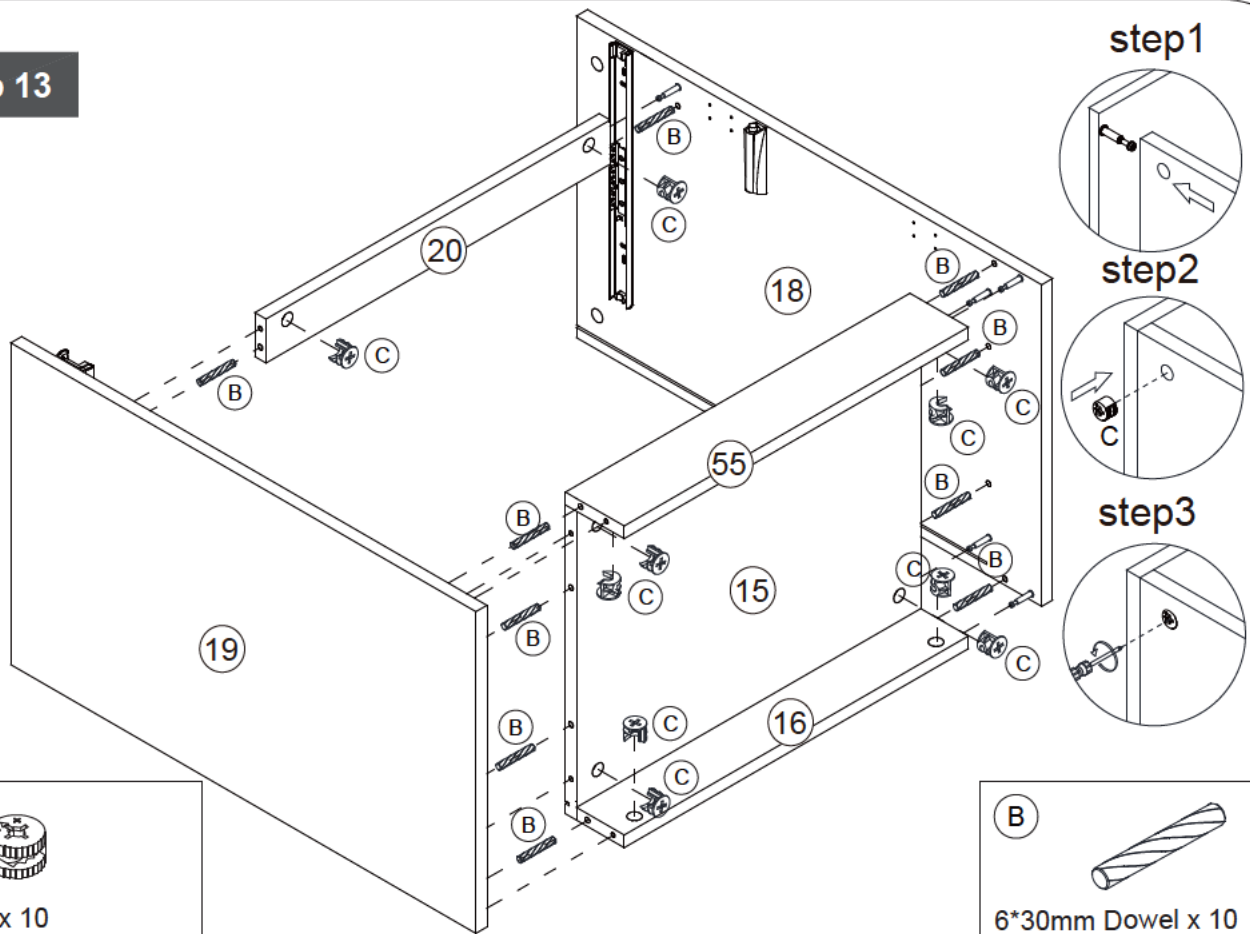

Step 14

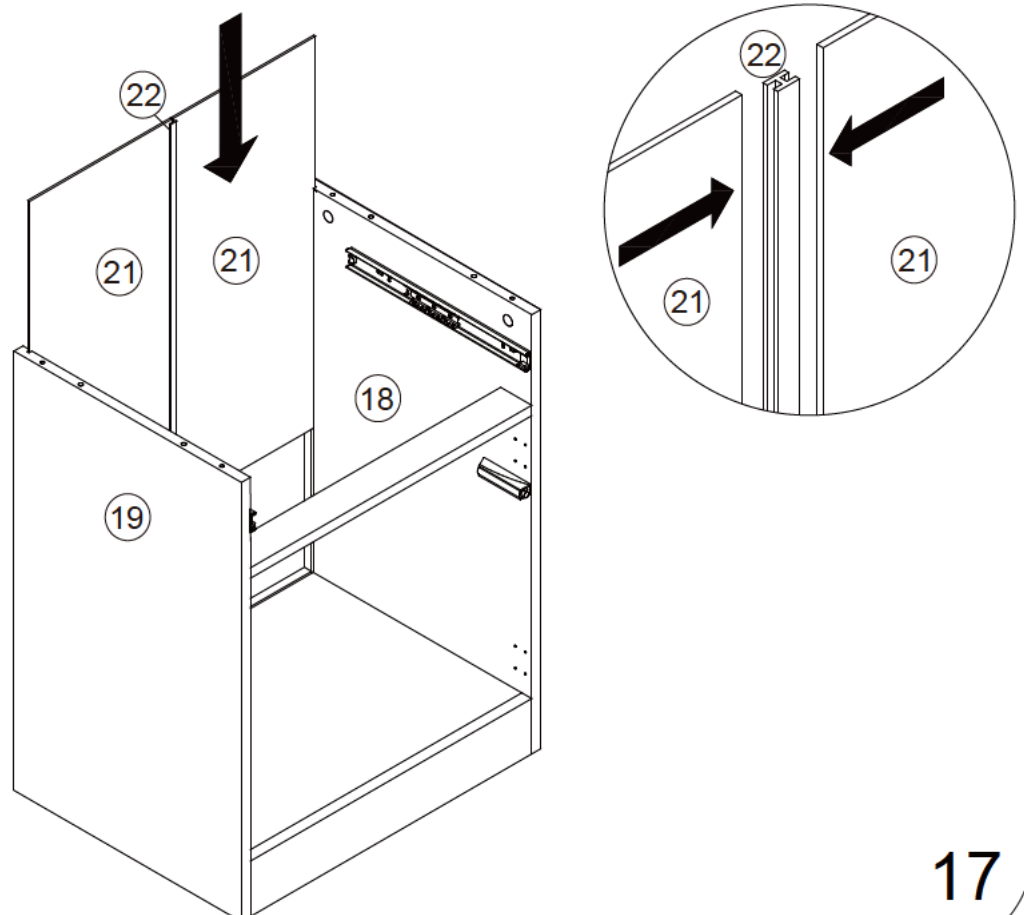

Assembly Instructions

Step 15

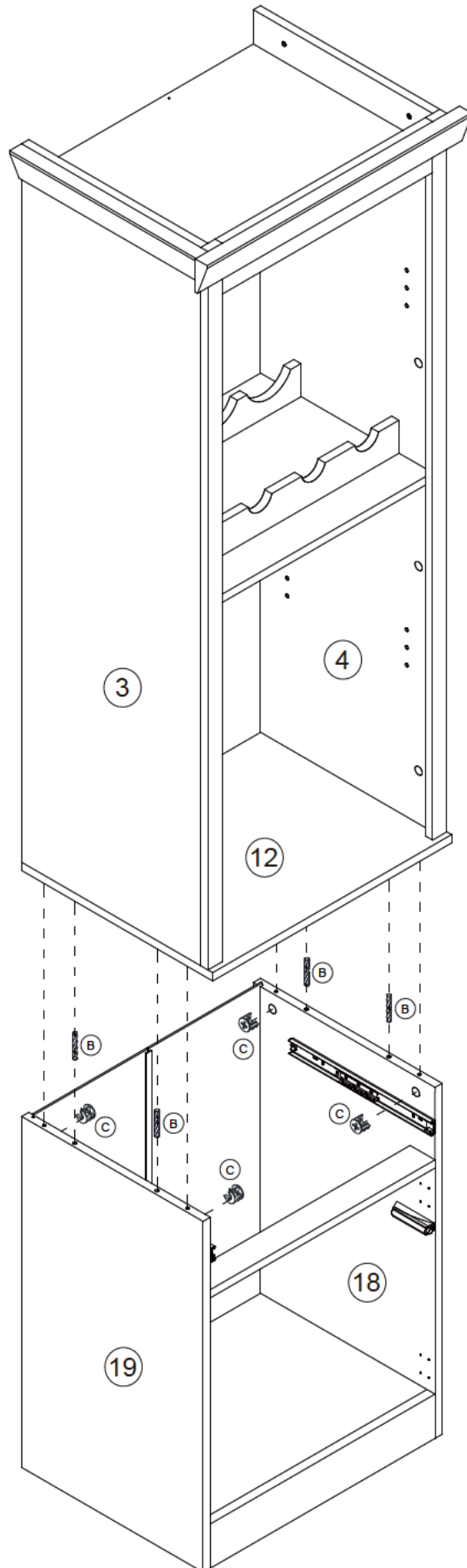

step 1

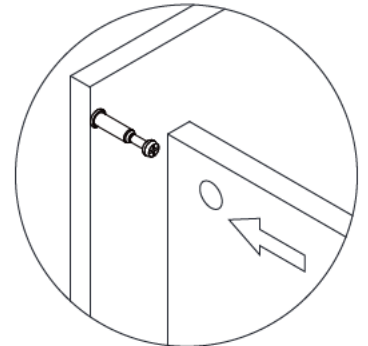

step 2

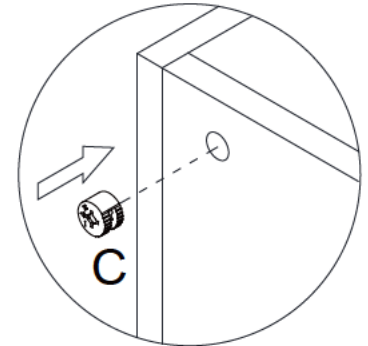

step 3

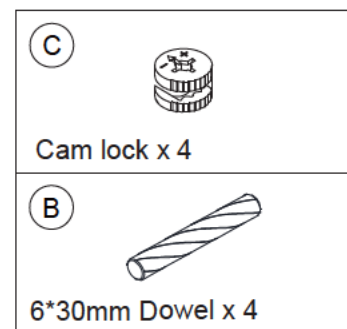
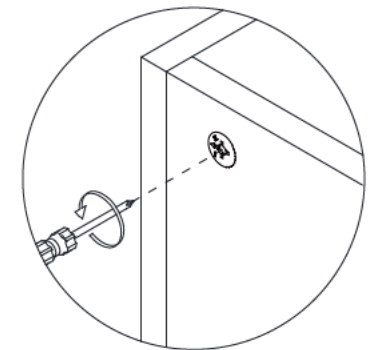

Assembly Instructions

Step 16

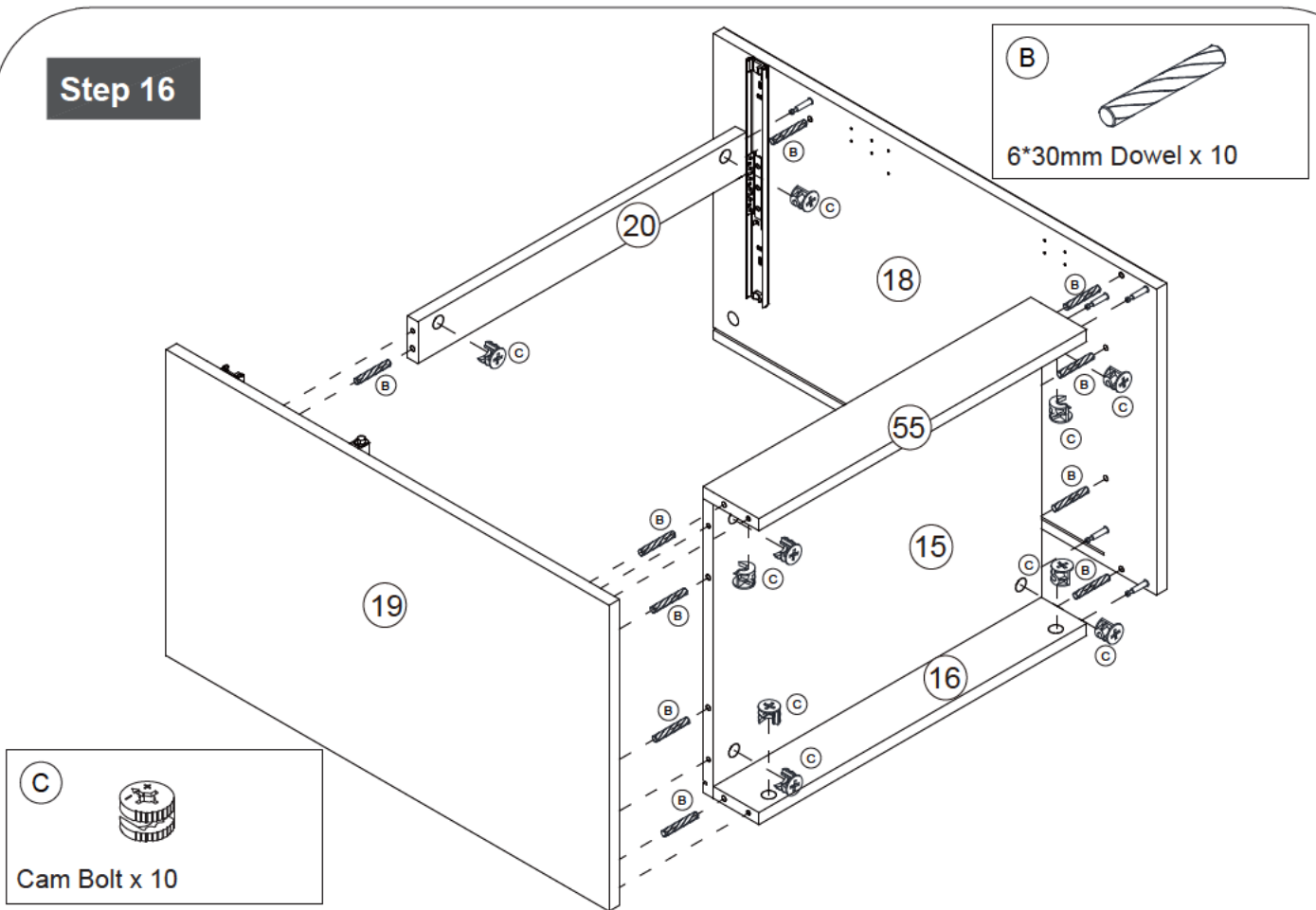

Step 17

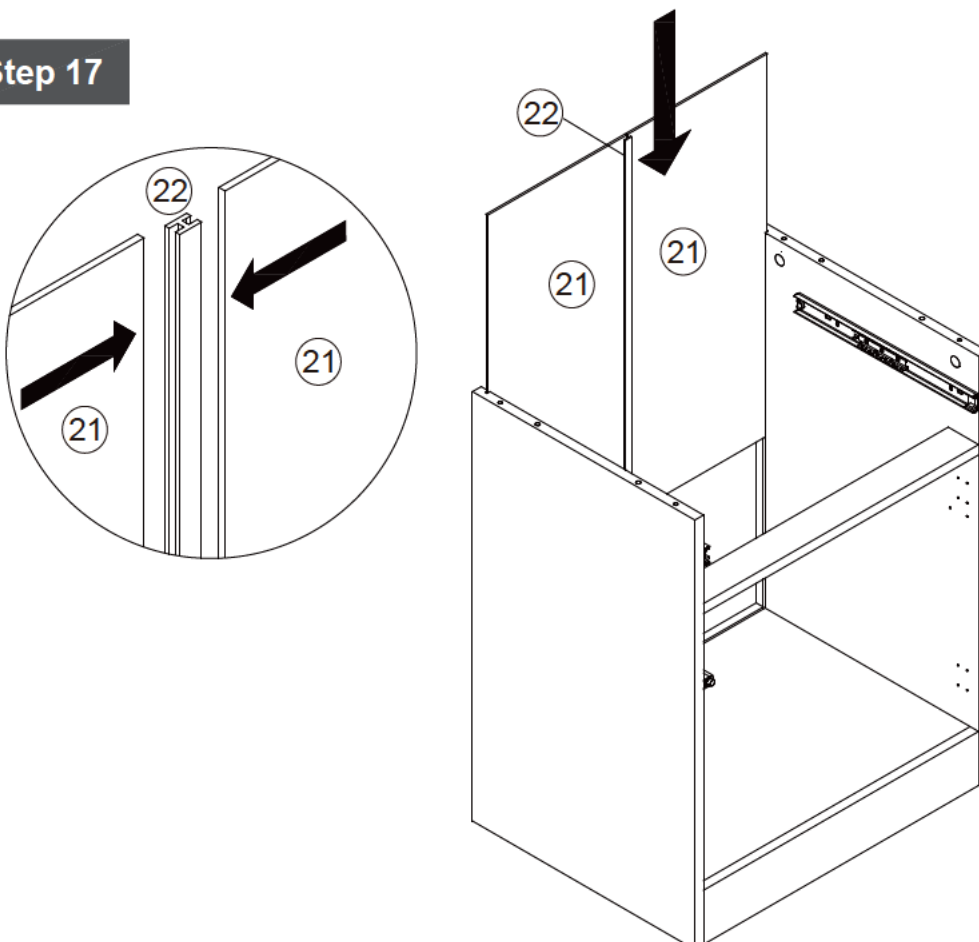

Assembly Instructions

Step 18

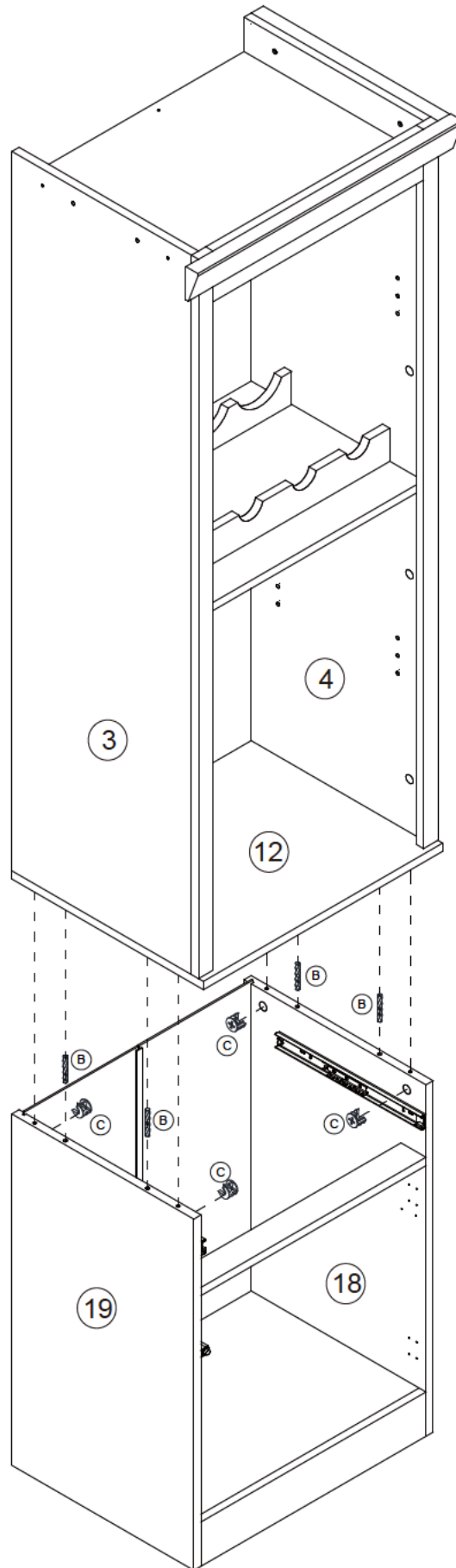

step 1

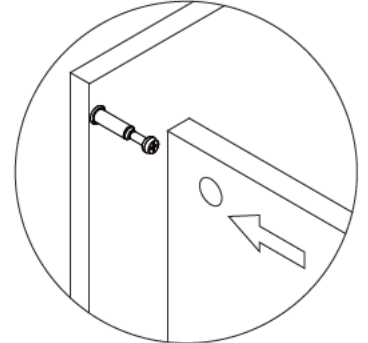

step 2

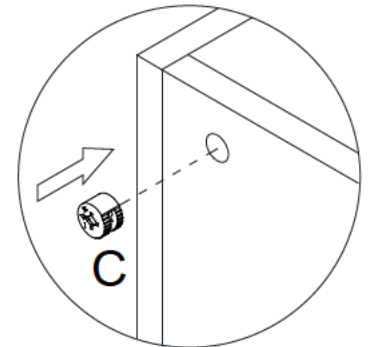

step 3

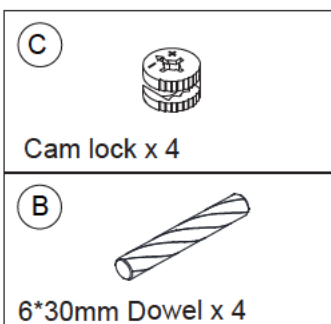
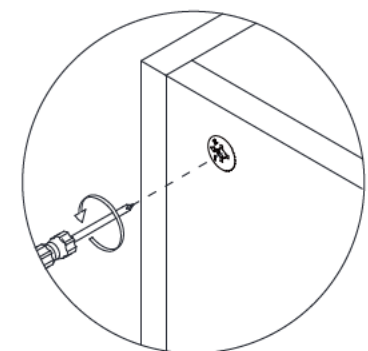

Assembly Instructions

Step 19

x2

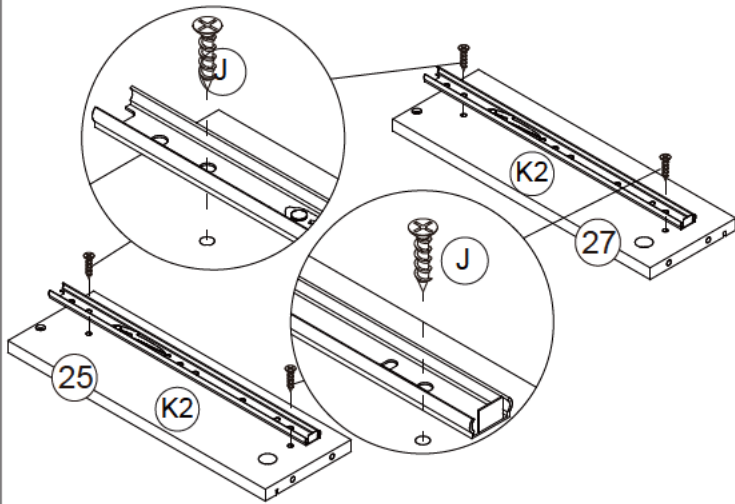

x2

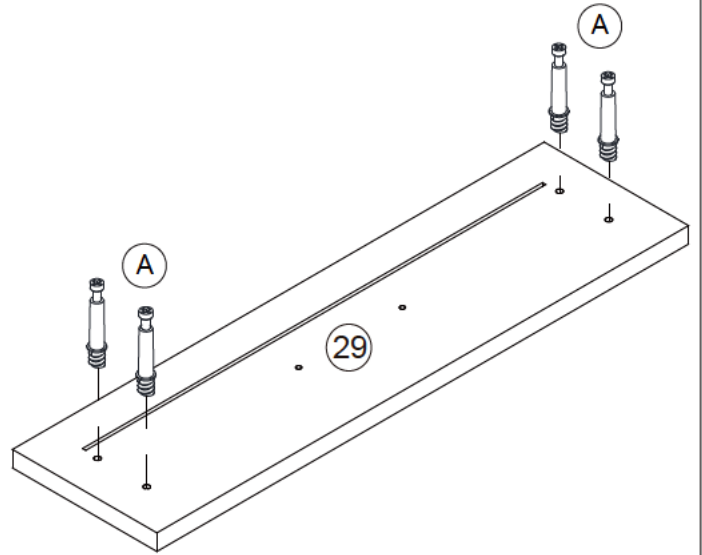

A

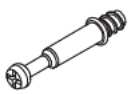

Cam Bolt x 8

J



3*12mm Screw x 8

K2



Slide x 4

Step 20

x2

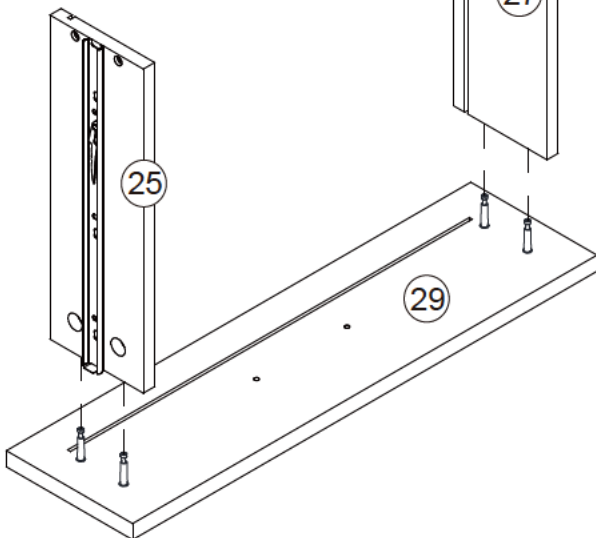

x2

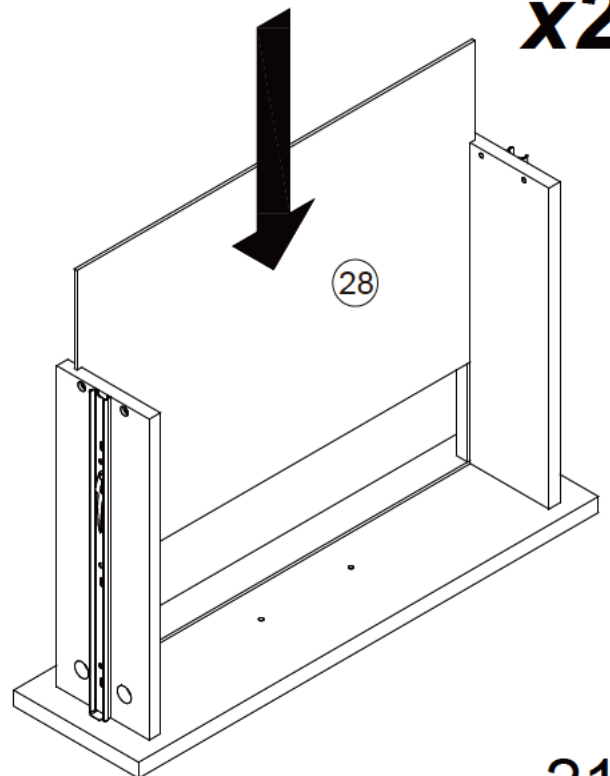

21

Assembly Instructions

Step 21

x2

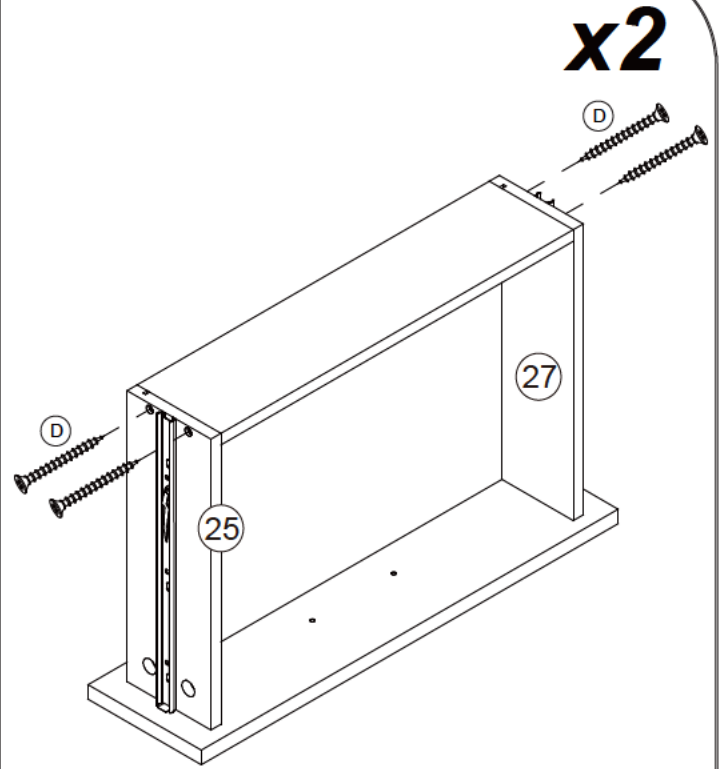
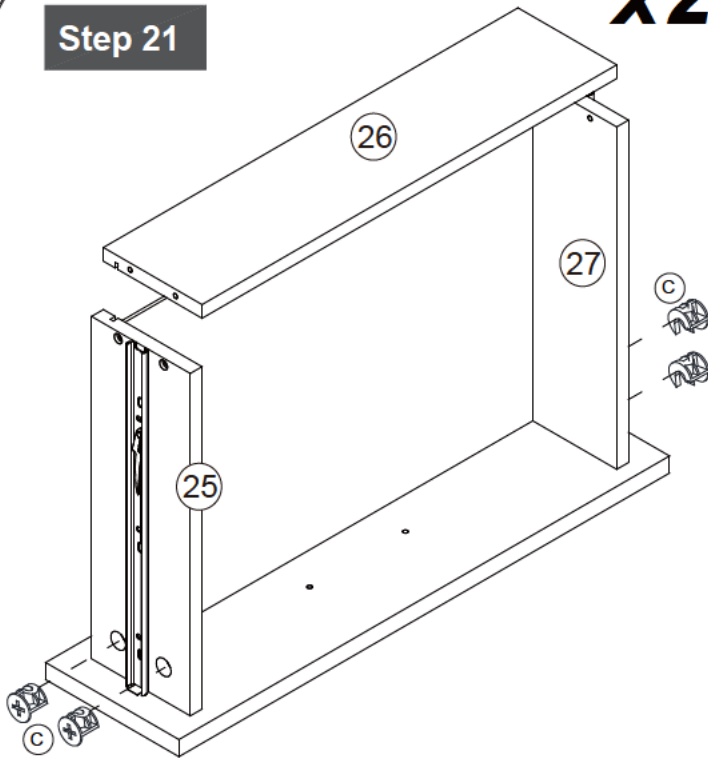

Cam lock x 8



4*30mm Screw x 8

Step 22

x2

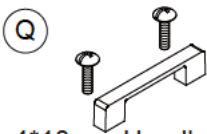
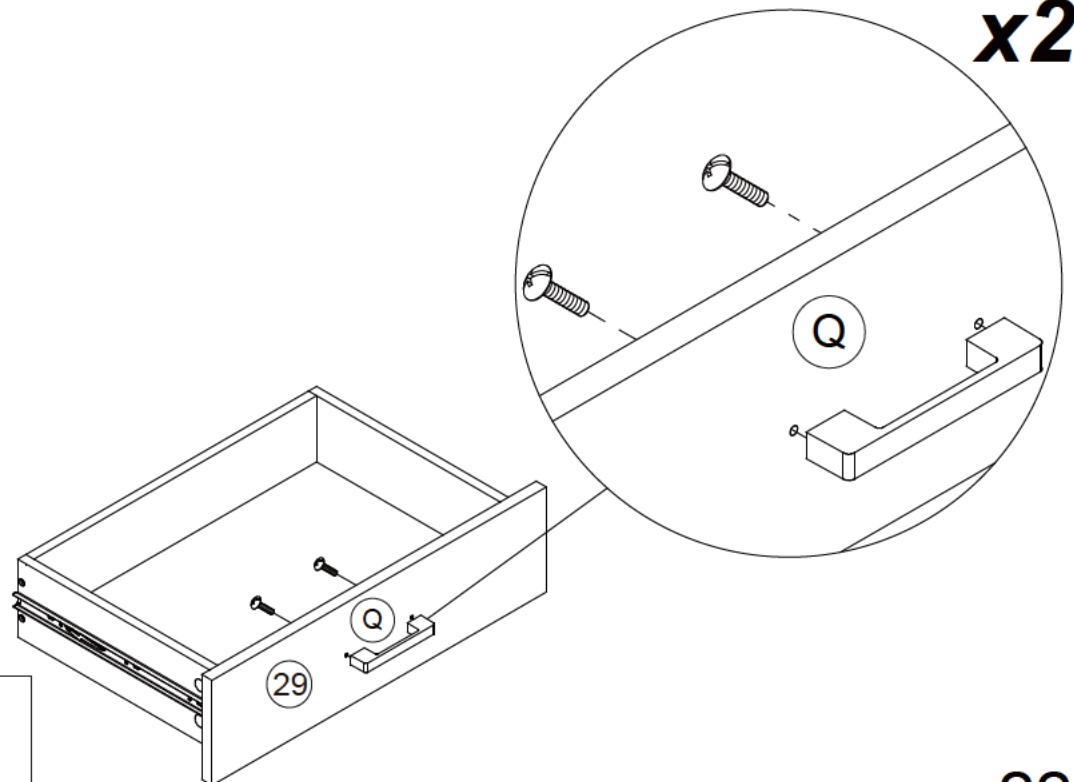

4*18mm Handle x 2set

22

Assembly Instructions

Step 23

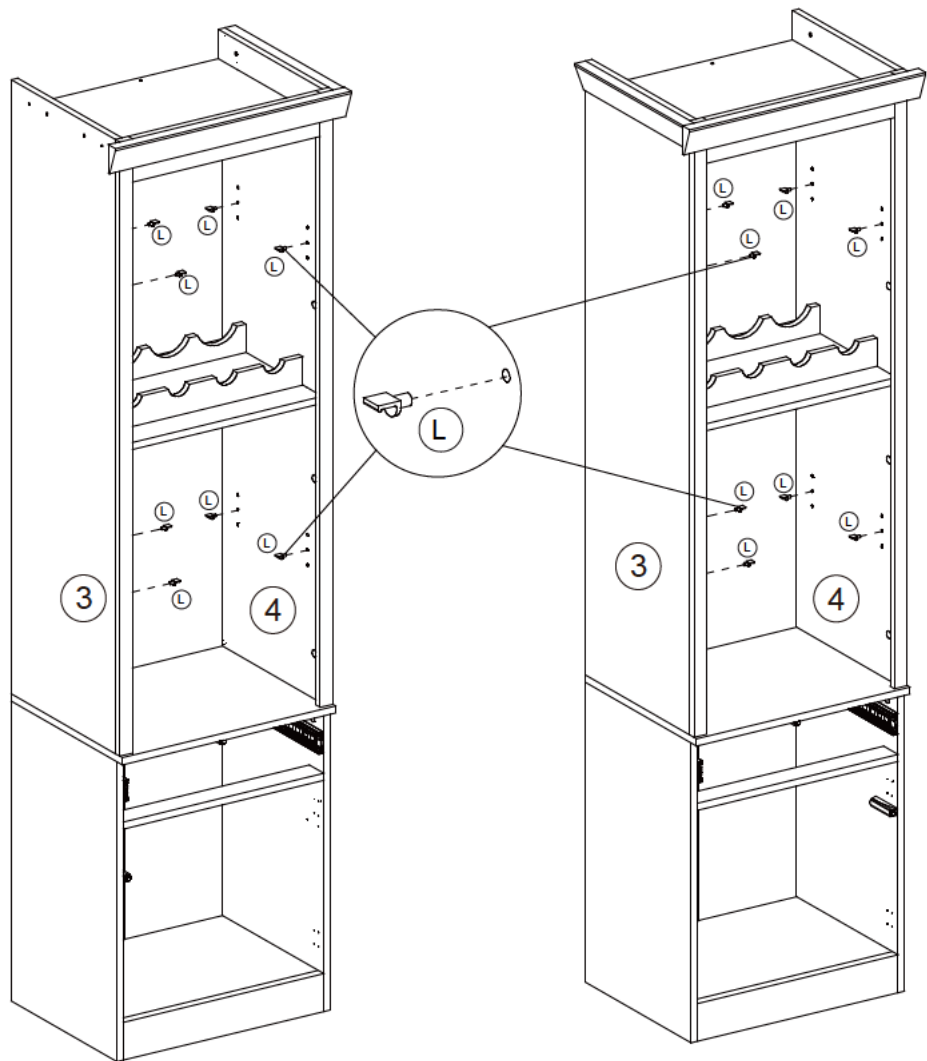

L



Shelf support pin x 16

Step 24

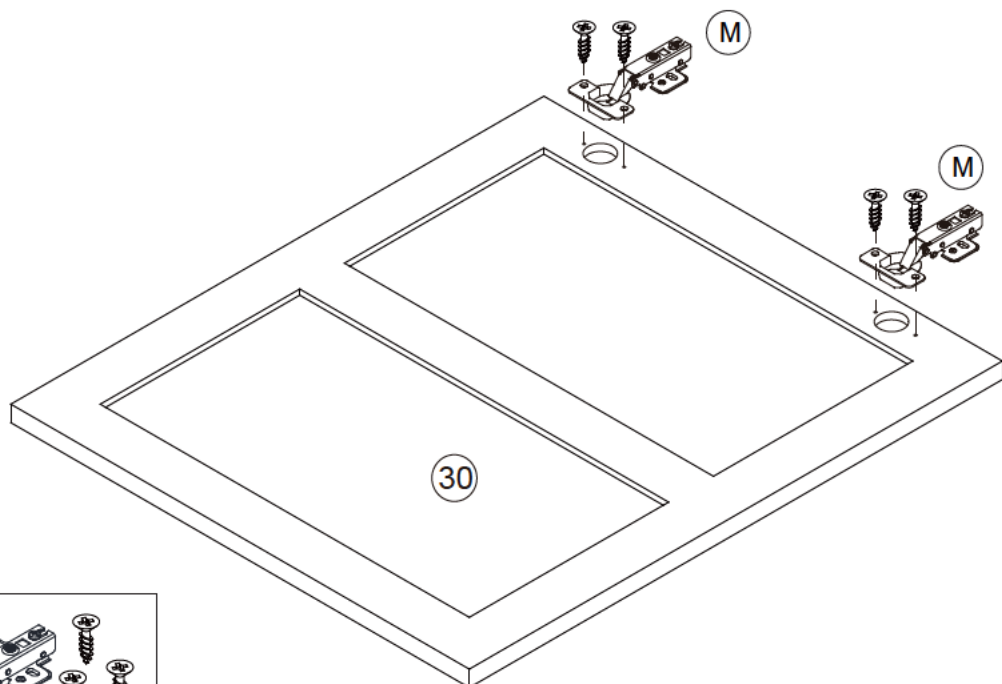

x2

M



3.5*14mm Hinge x 4set

23

Assembly Instructions

Step 25

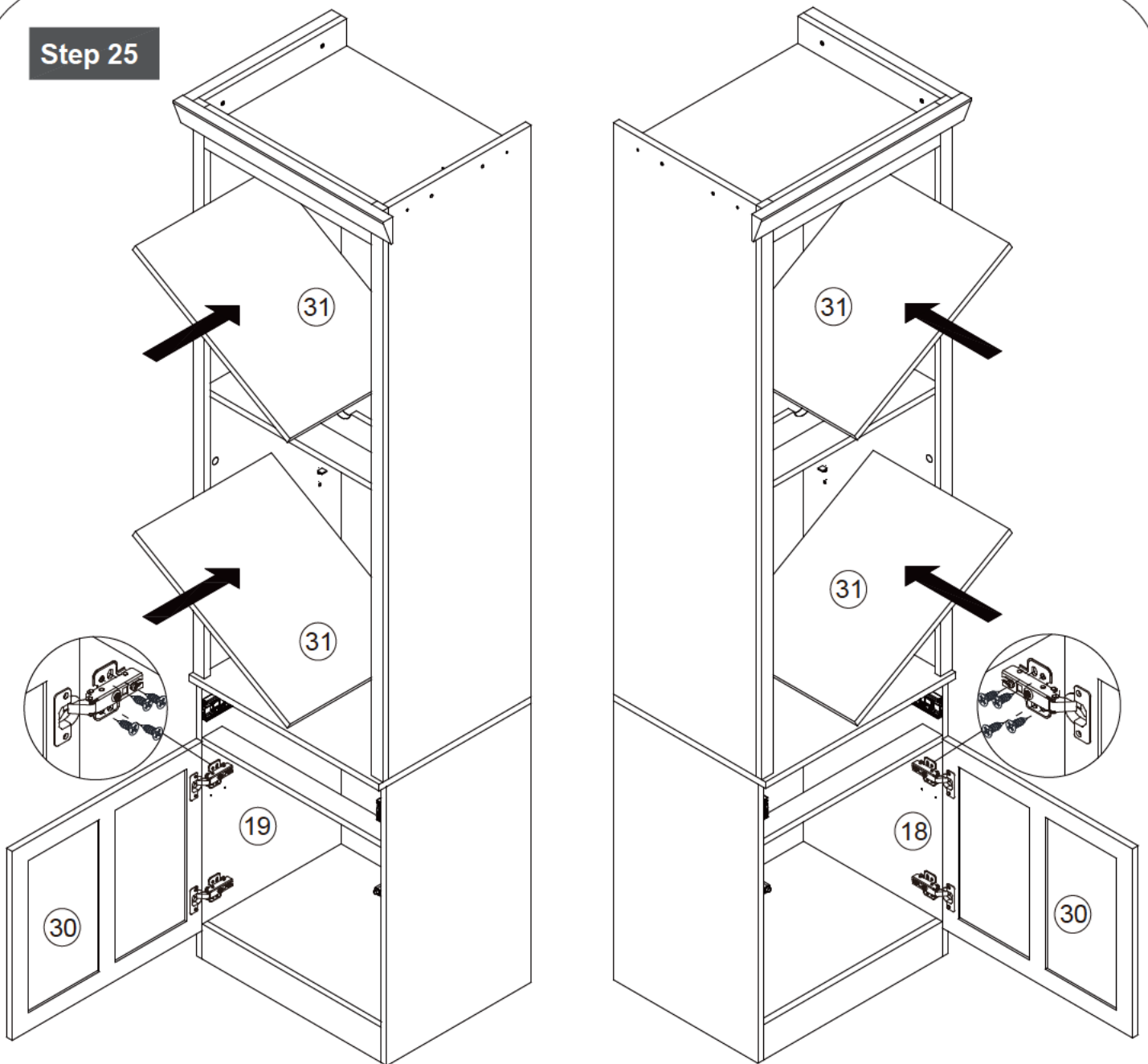

If the door can't close, please adjust the hinges as below.

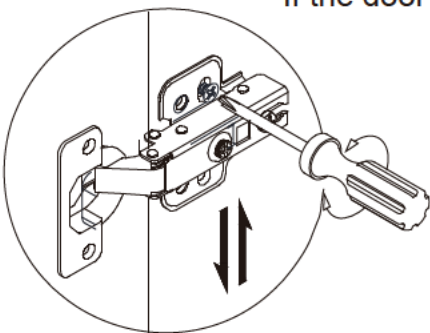

This is used to adjust the door panel in the up and down direction.

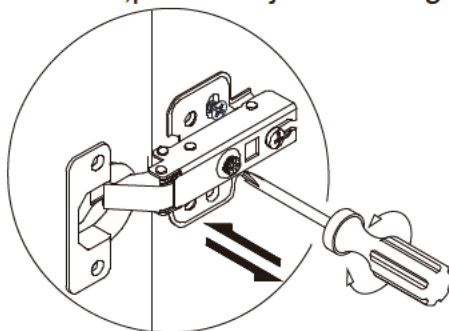

This is used to adjust the door panel in the left and right direction.

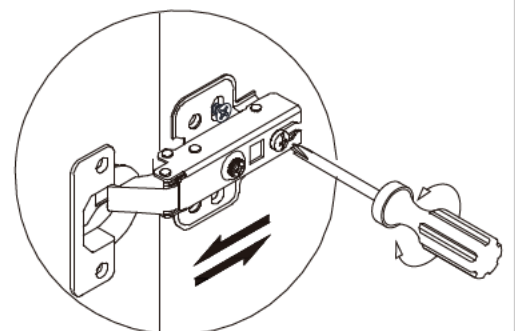

This is used to adjust the door panel in the front and rear.

Assembly Instructions

Step 26

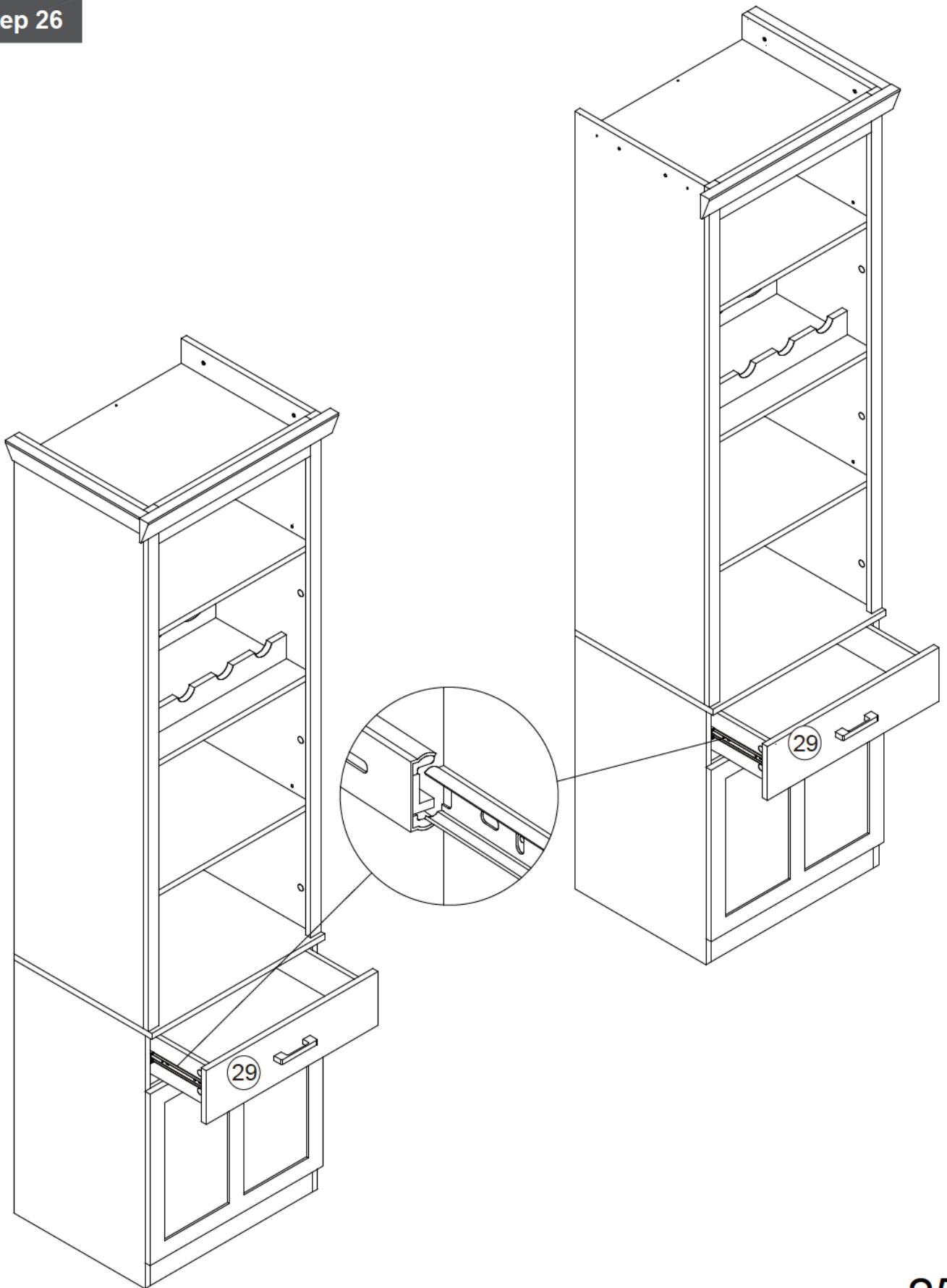

Assembly Instructions

Step 27

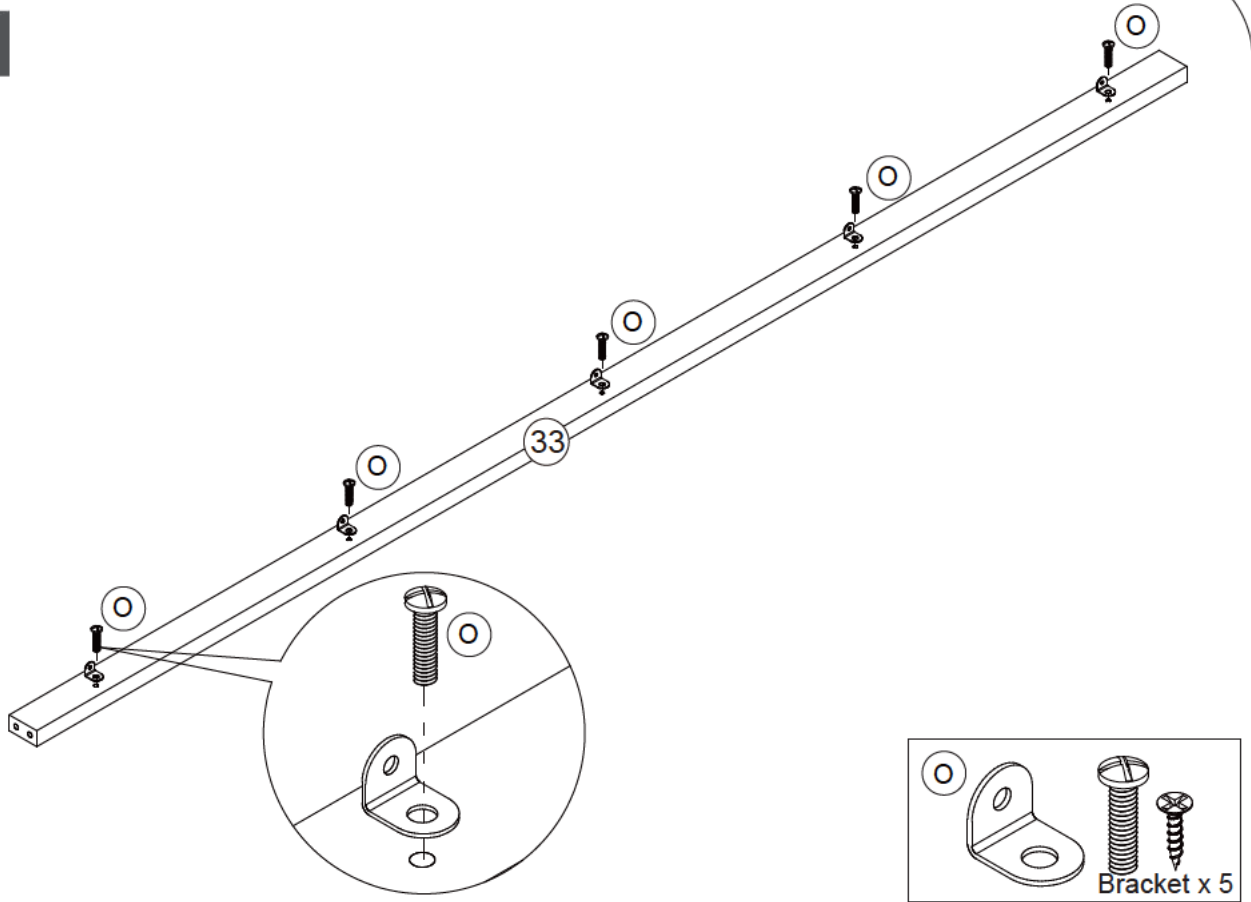

Step 28

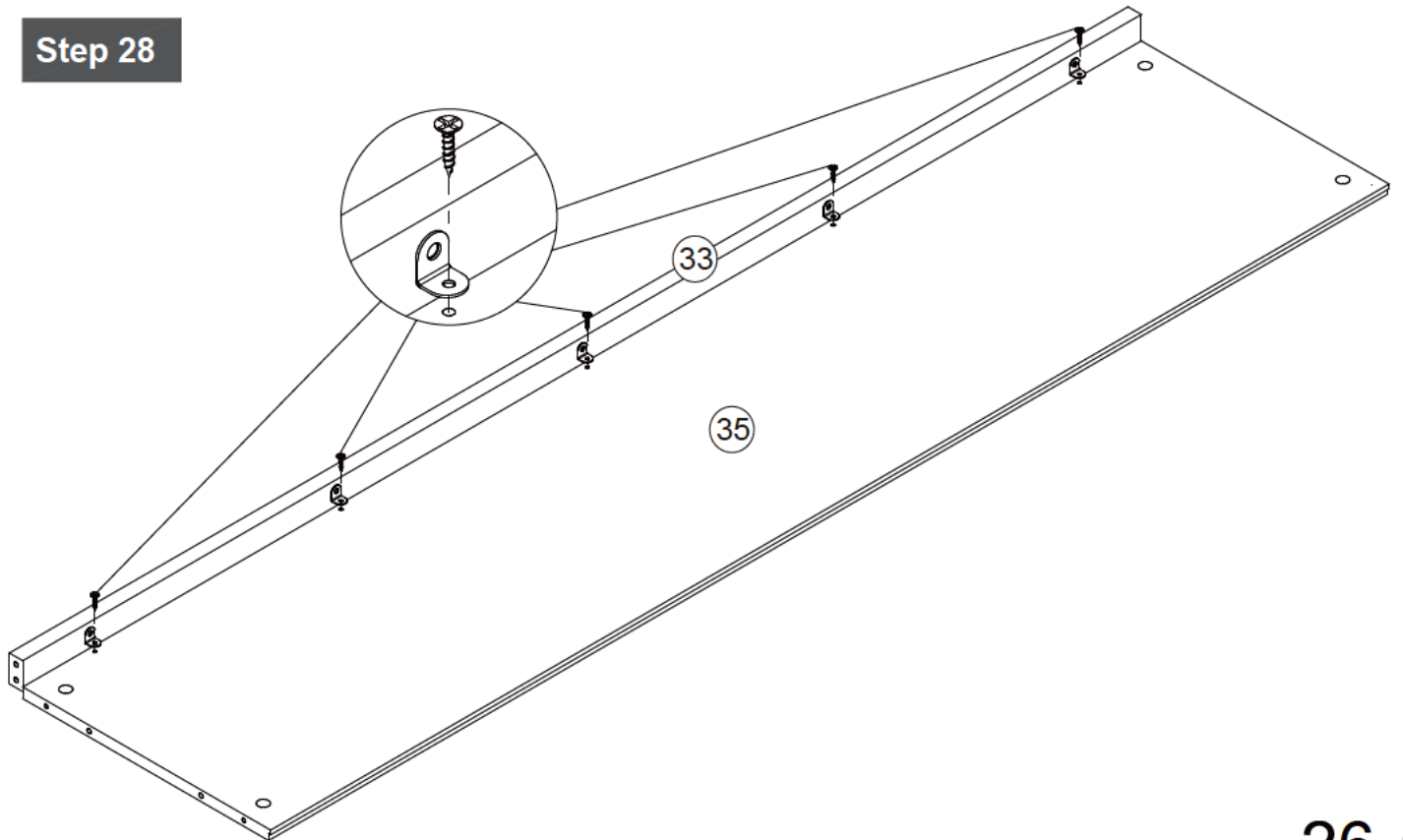

Assembly Instructions

Step 29

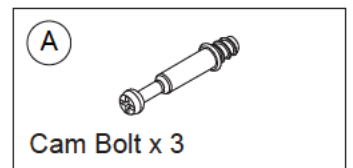
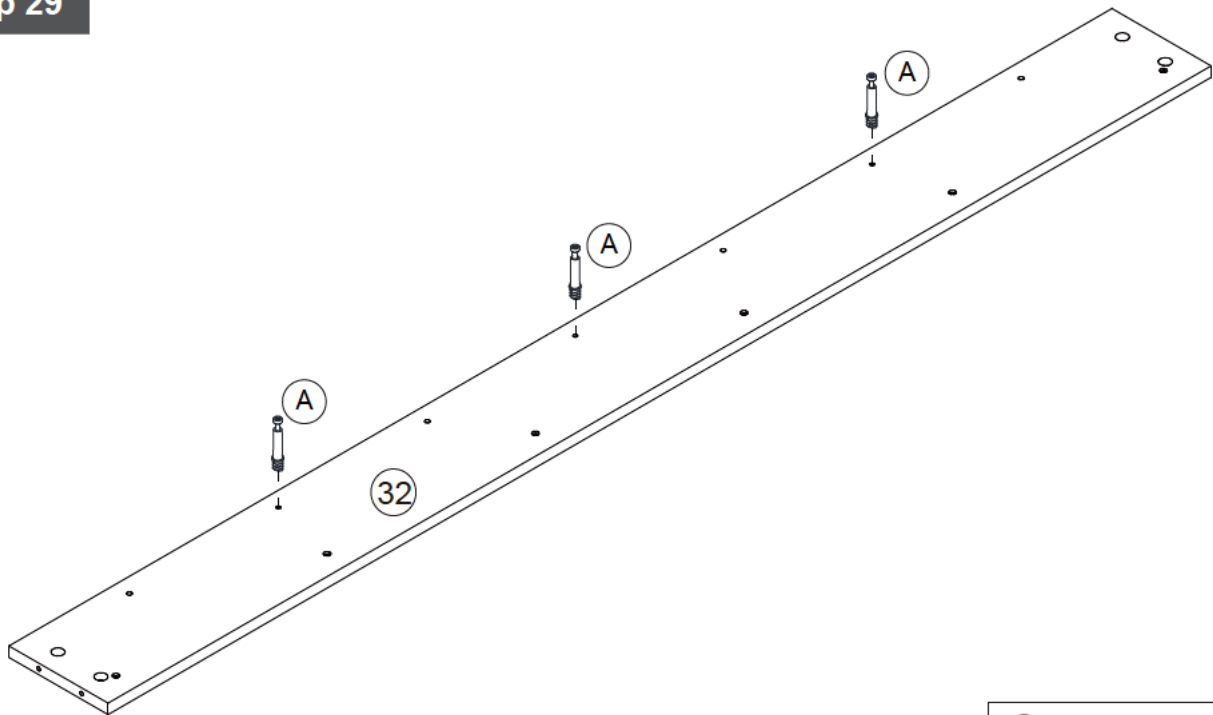

Step 30

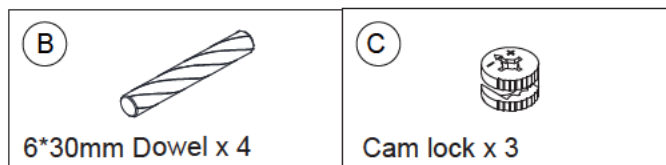
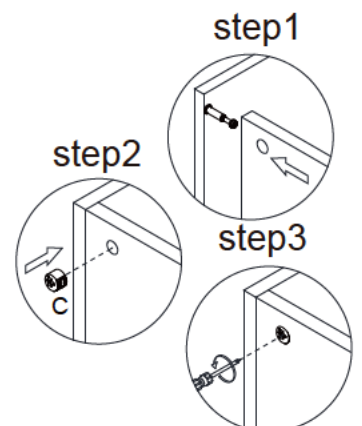
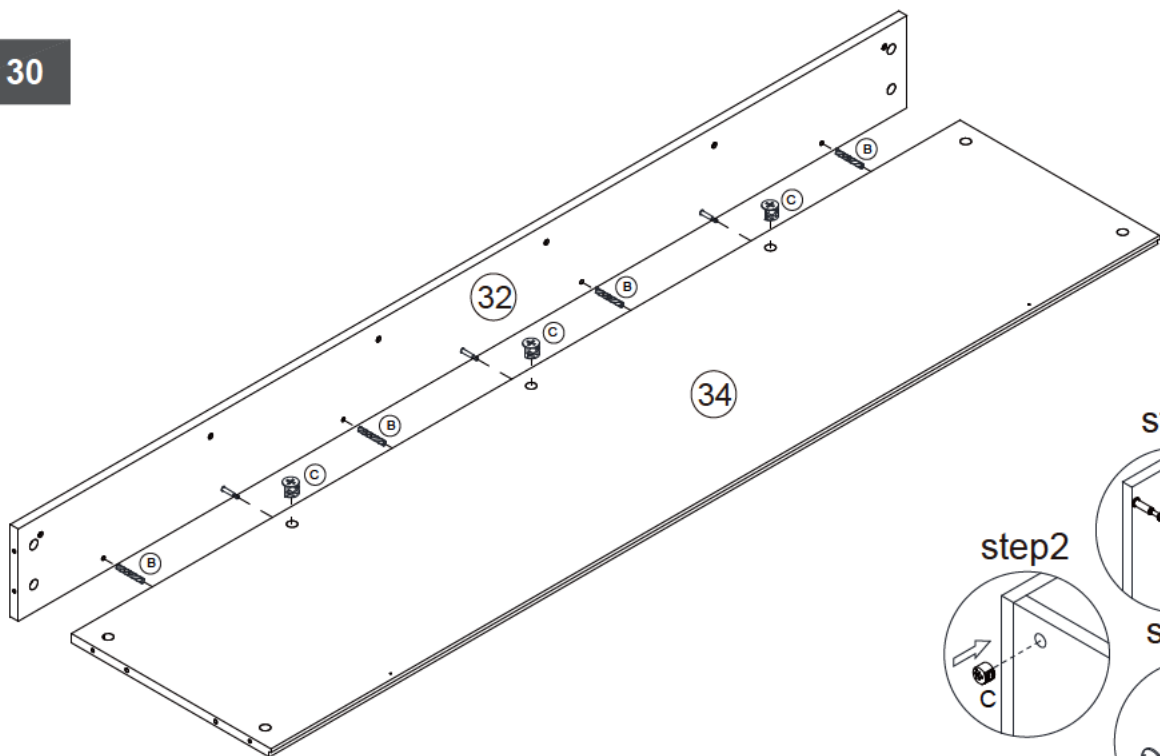

Assembly Instructions

Step 31

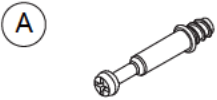
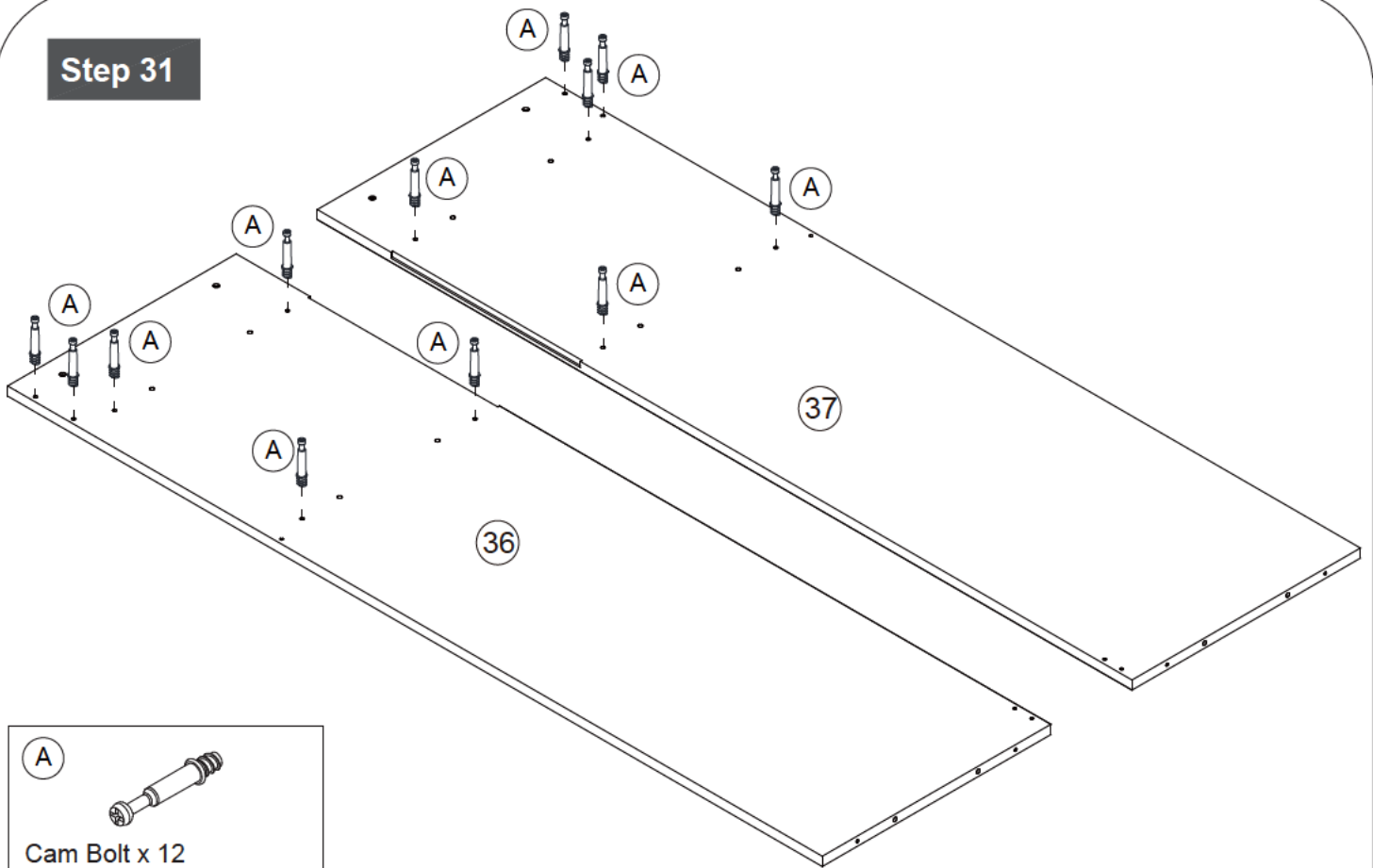

Cam Bolt x 12

Step 32

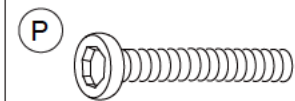
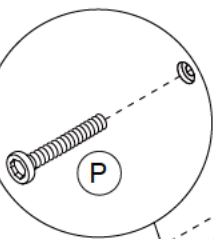
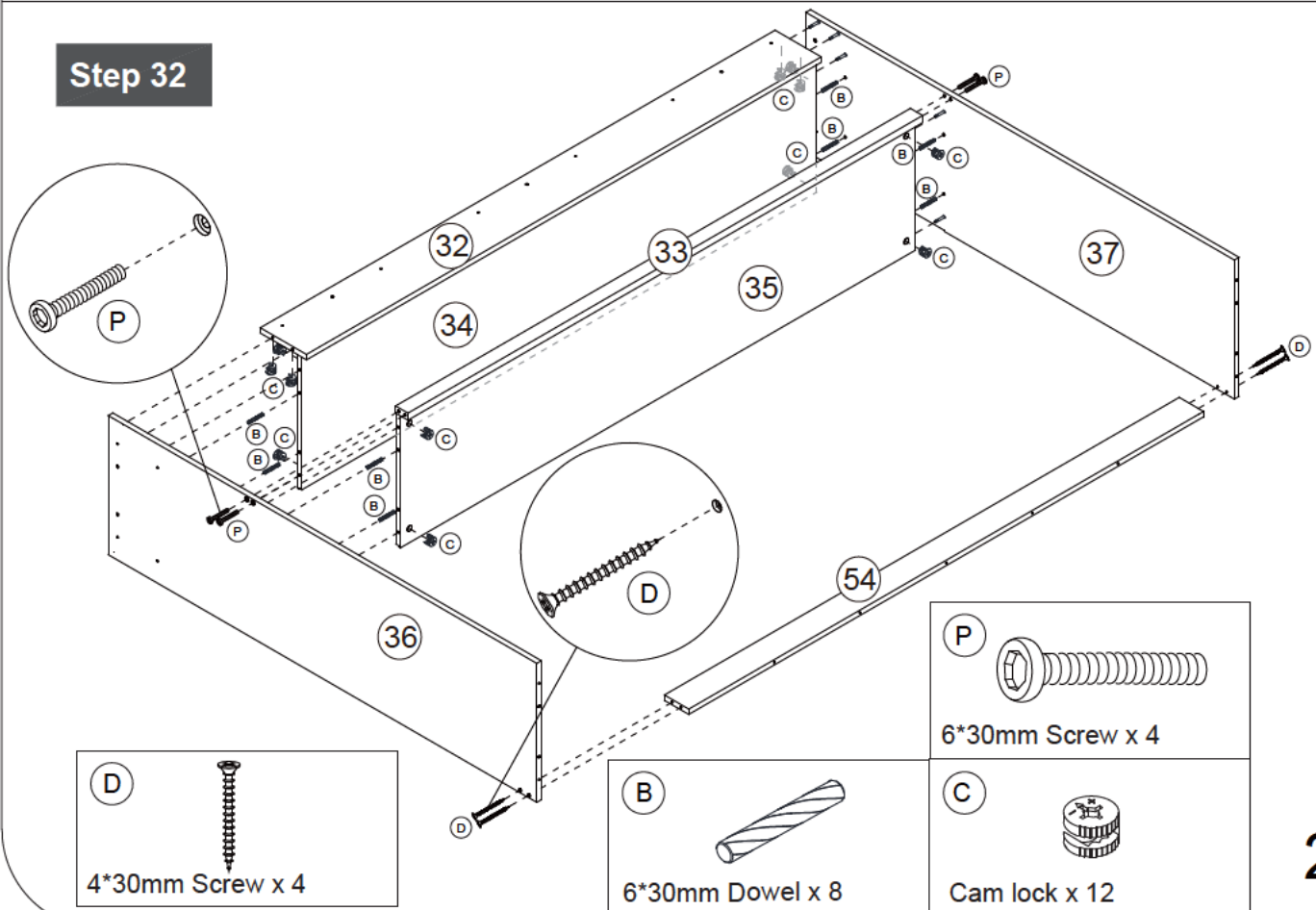

6*30mm Screw x 4



4*30mm Screw x 4



6*30mm Dowel x 8



Cam lock x 12

Assembly Instructions

Step 33

Please flip carefully!

It's better if two people work together in this step.

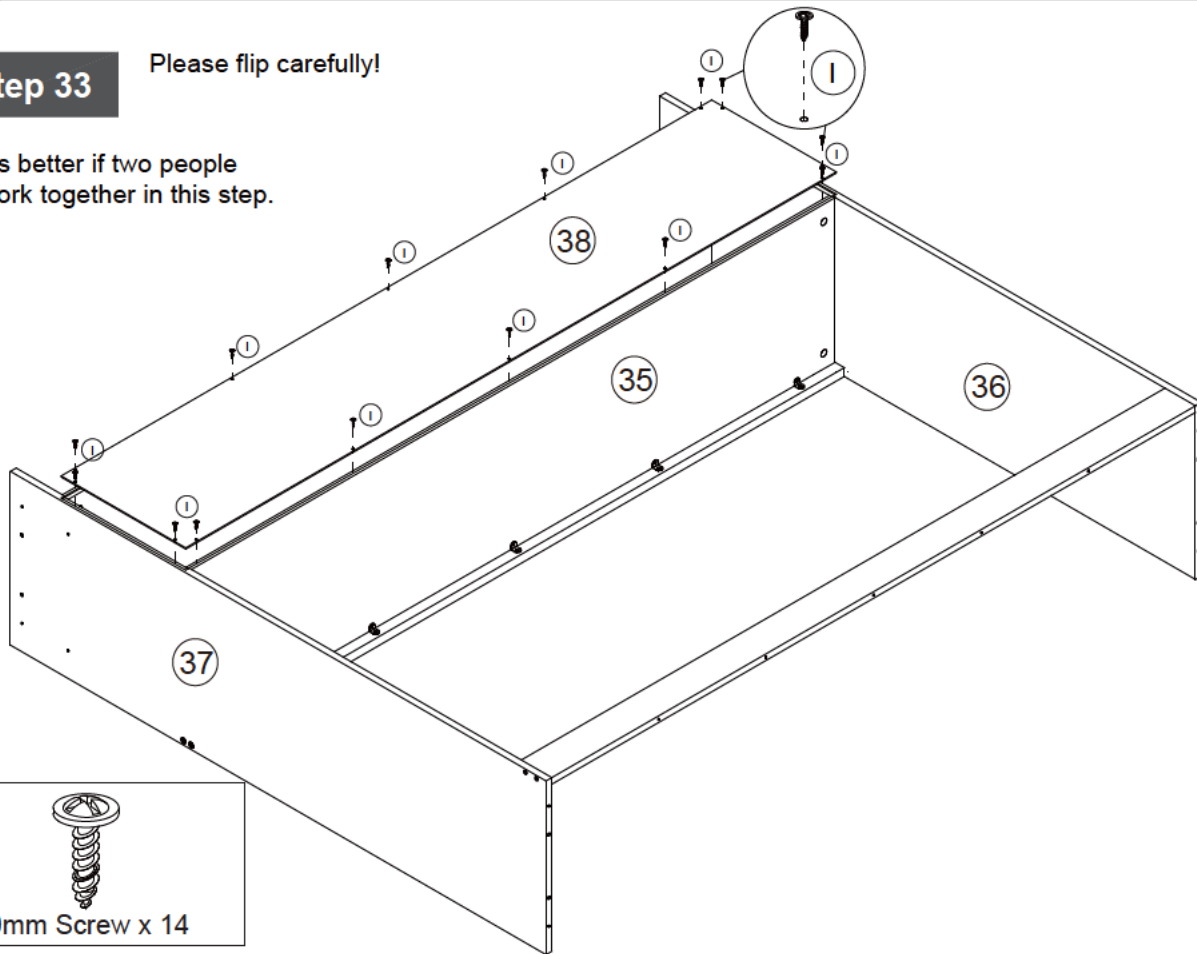

Step 34

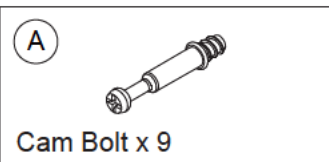
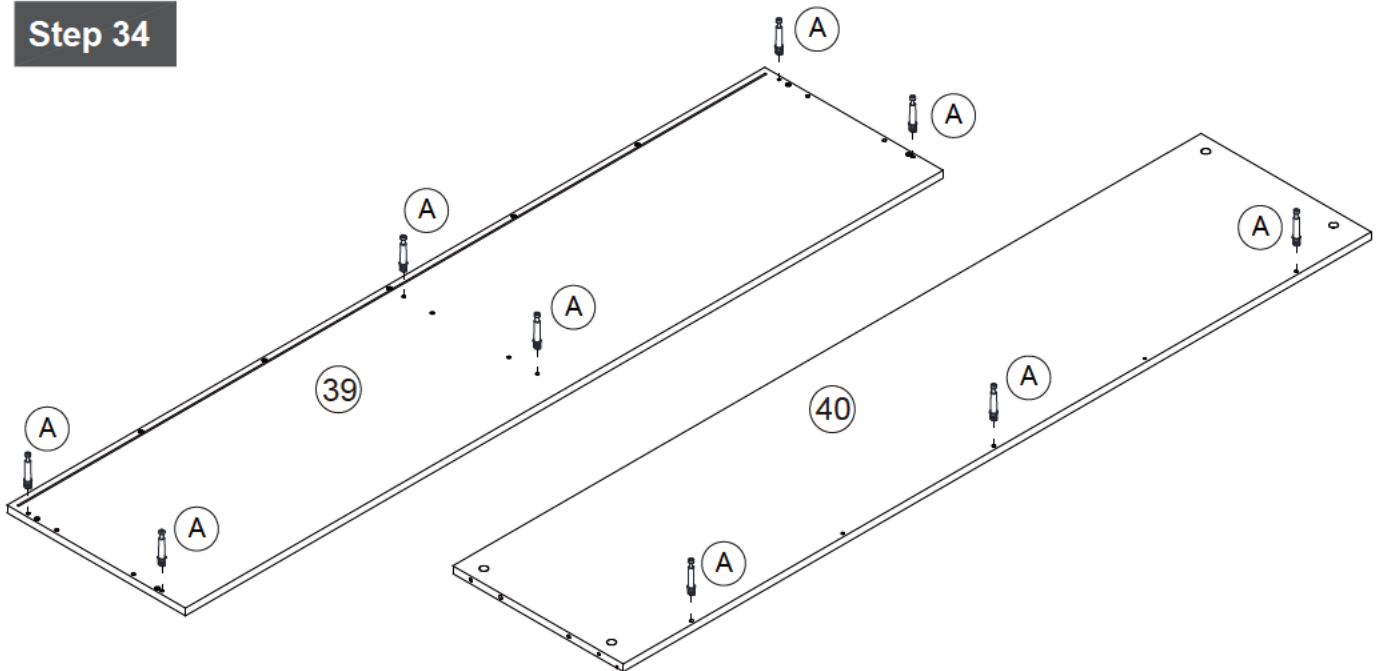

Assembly Instructions

Step 35

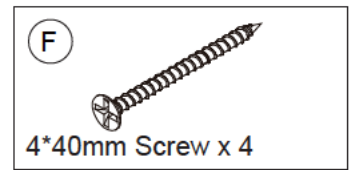
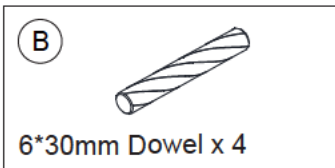
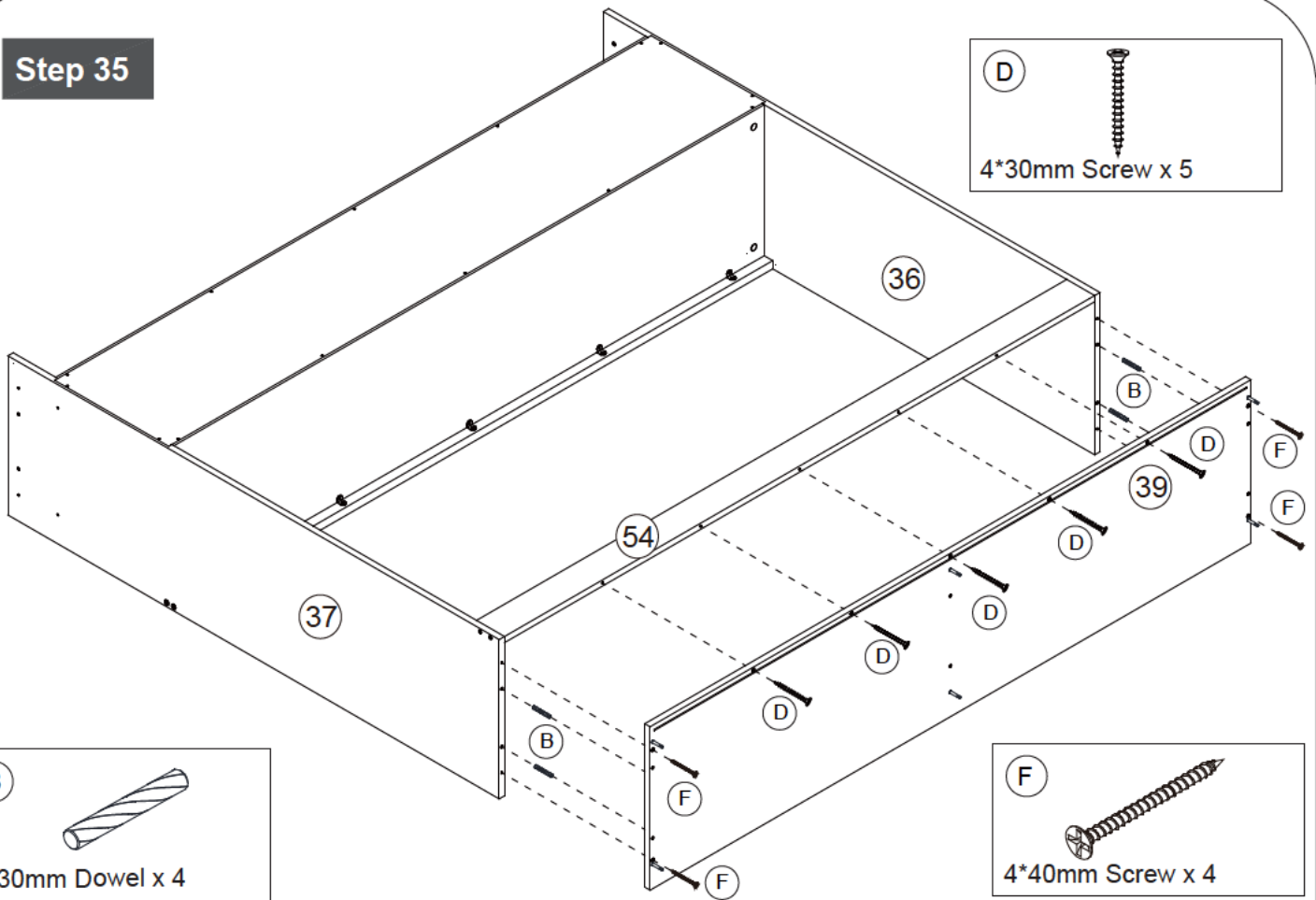

Step 36

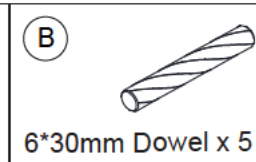
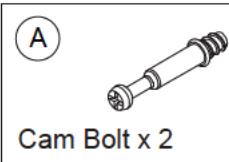
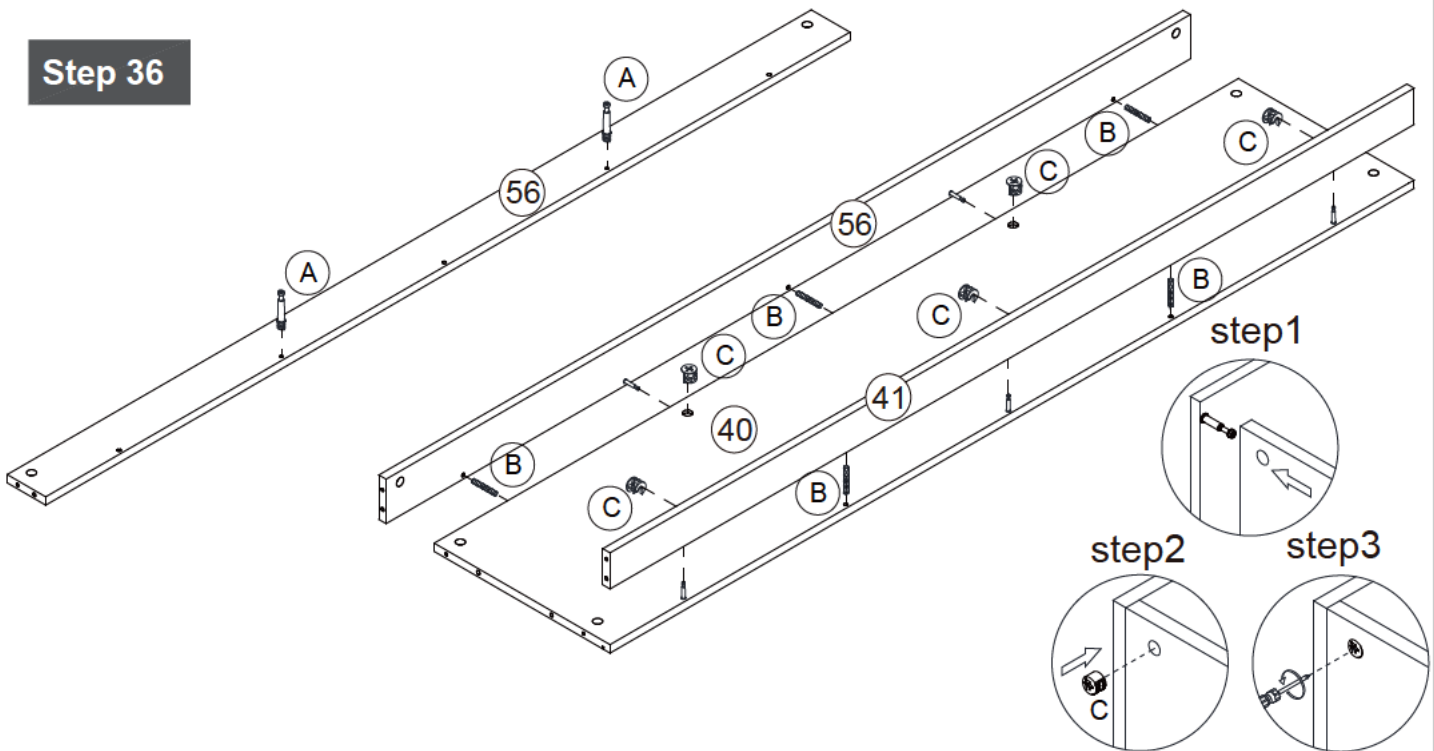

Assembly Instructions

Step 37

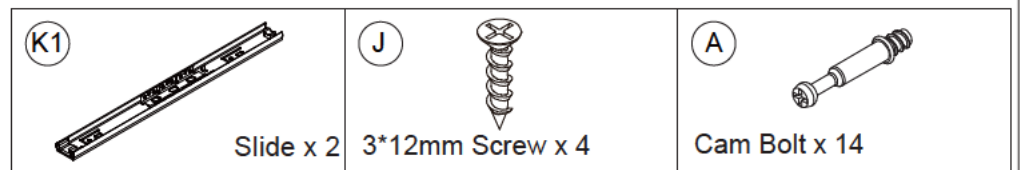
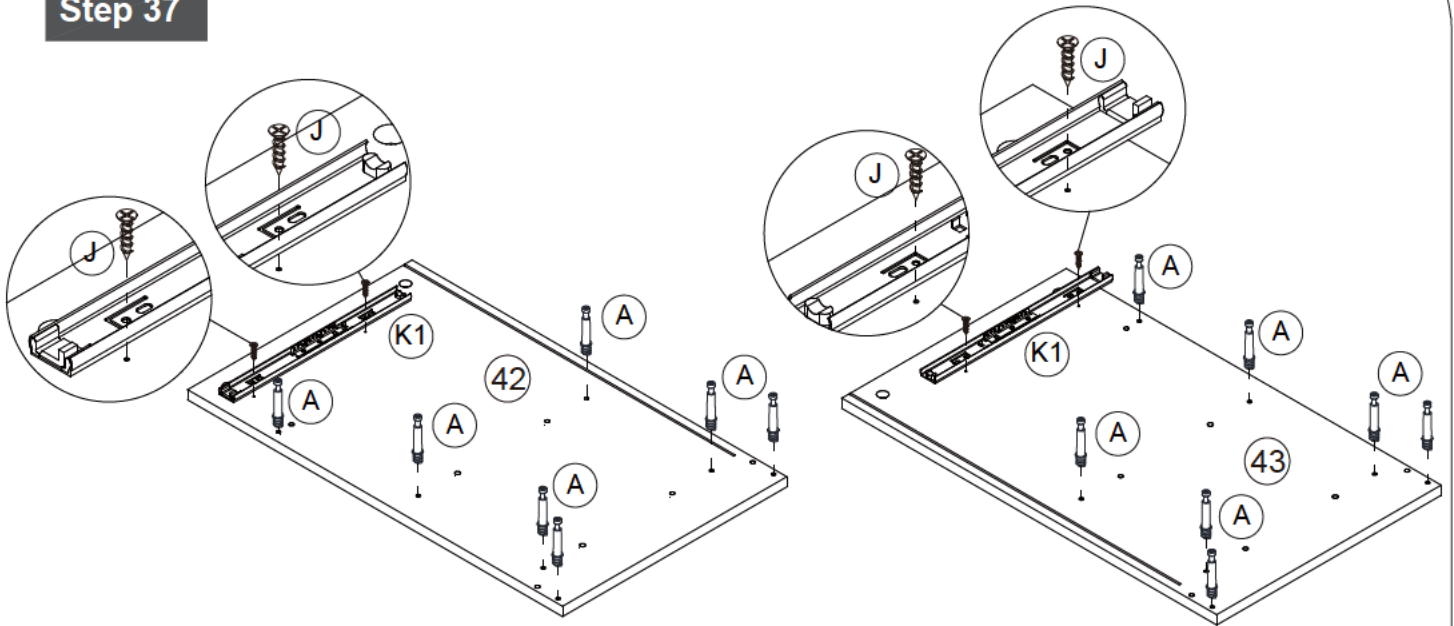

Step 38

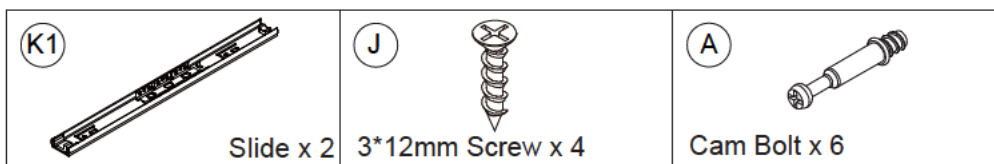
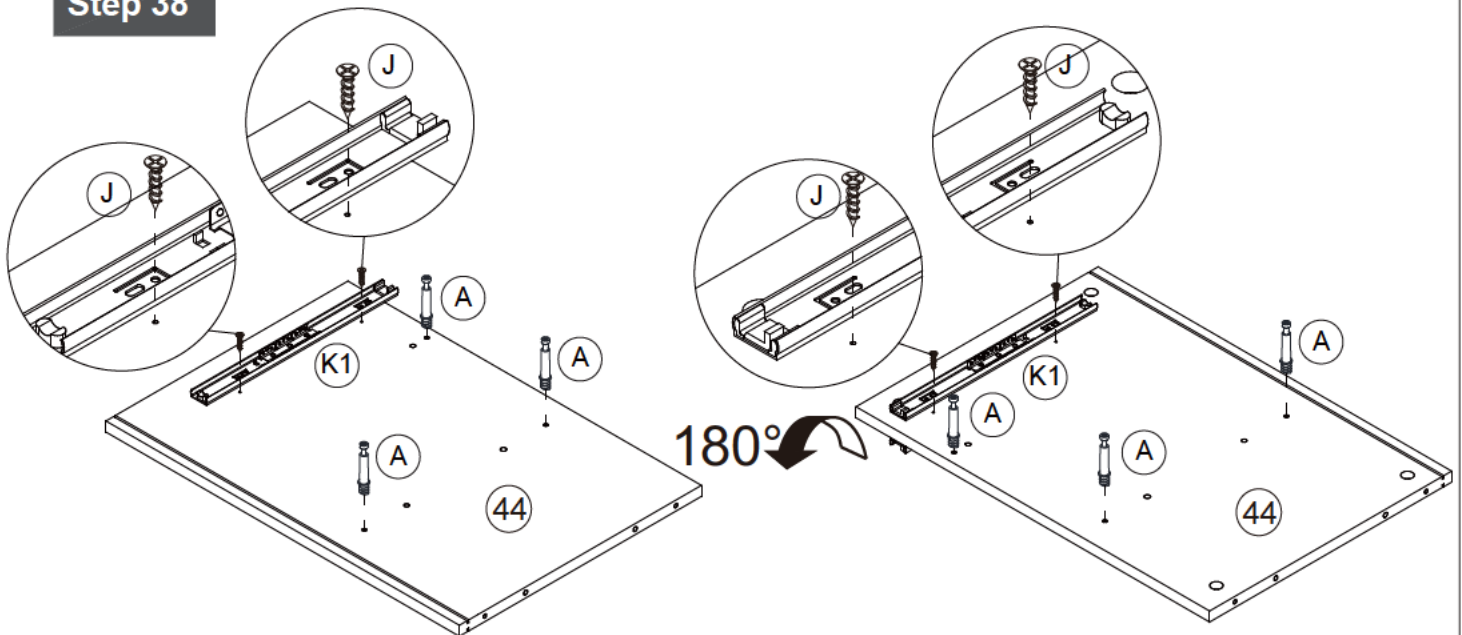

Assembly Instructions

Step 39

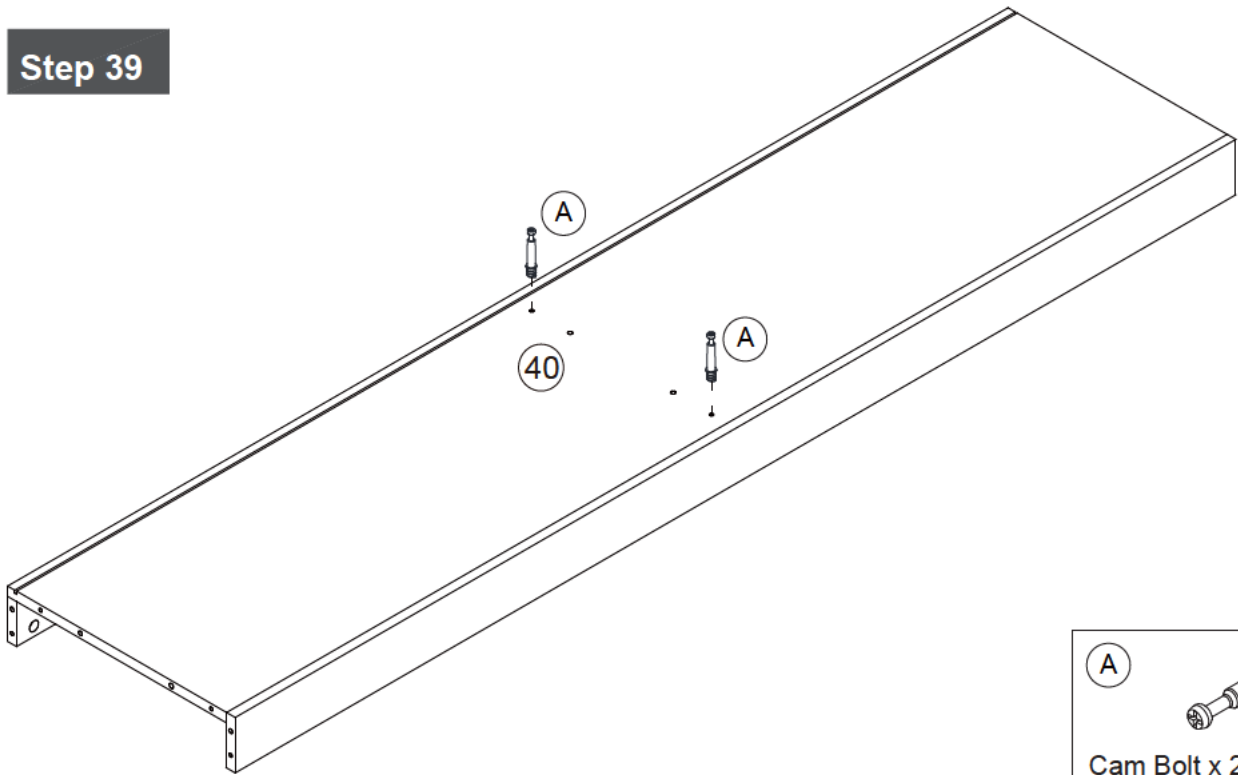

Step 40

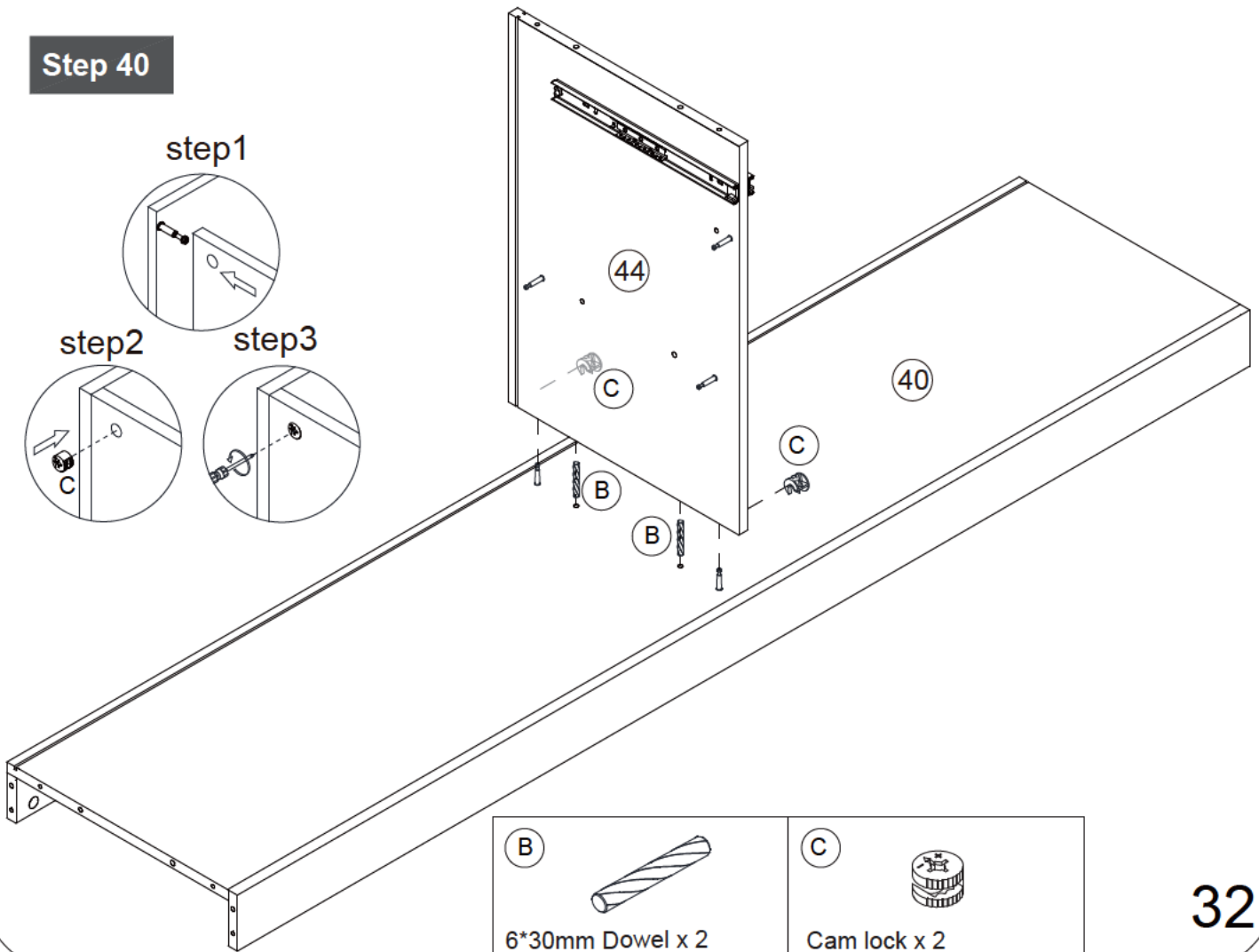

Assembly Instructions

Step 41

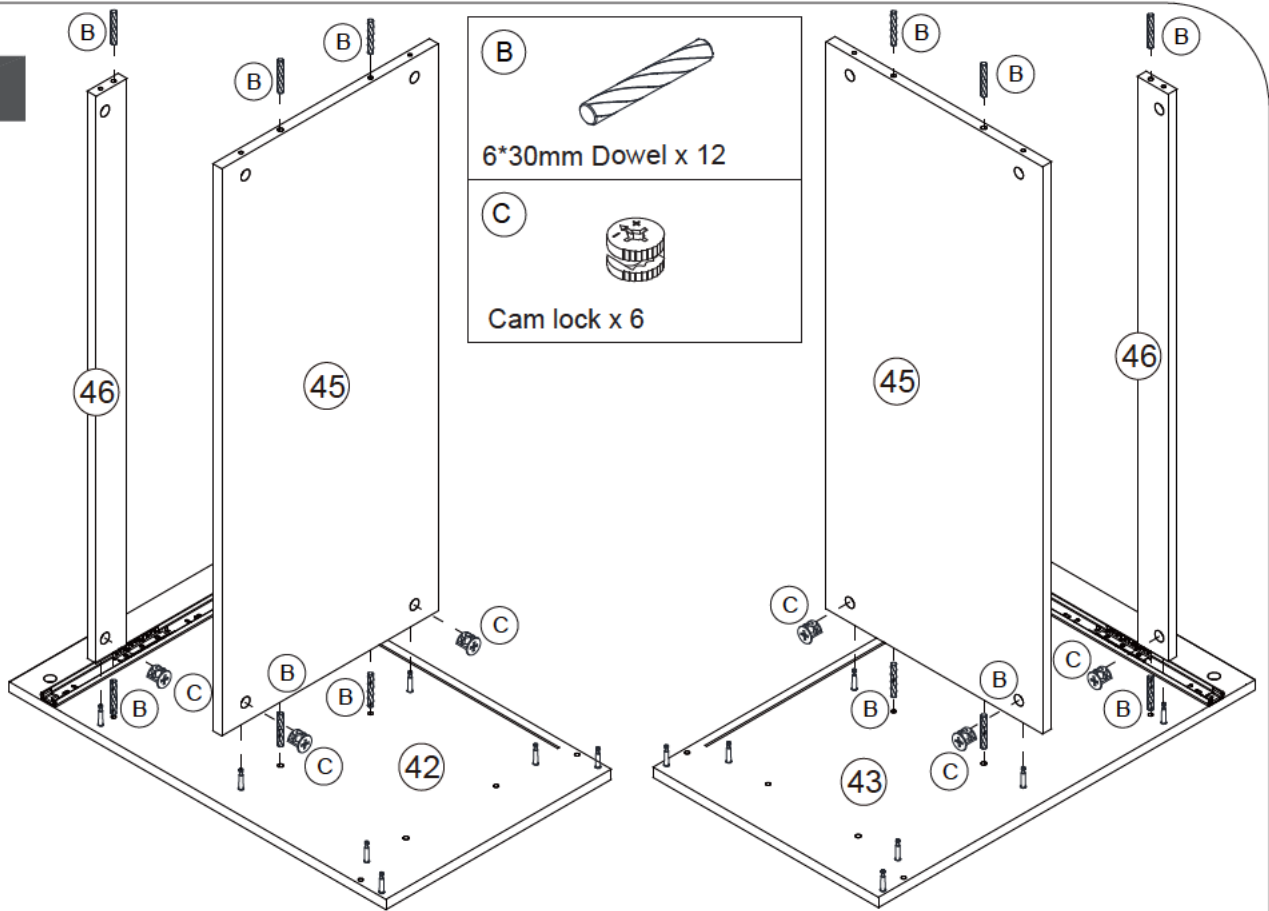

Step 42

It's better if two people work together in next steps.



Assembly Instructions

Step 43

step1

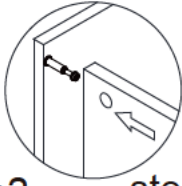

step2

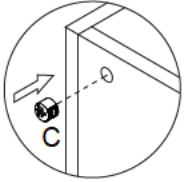

step3

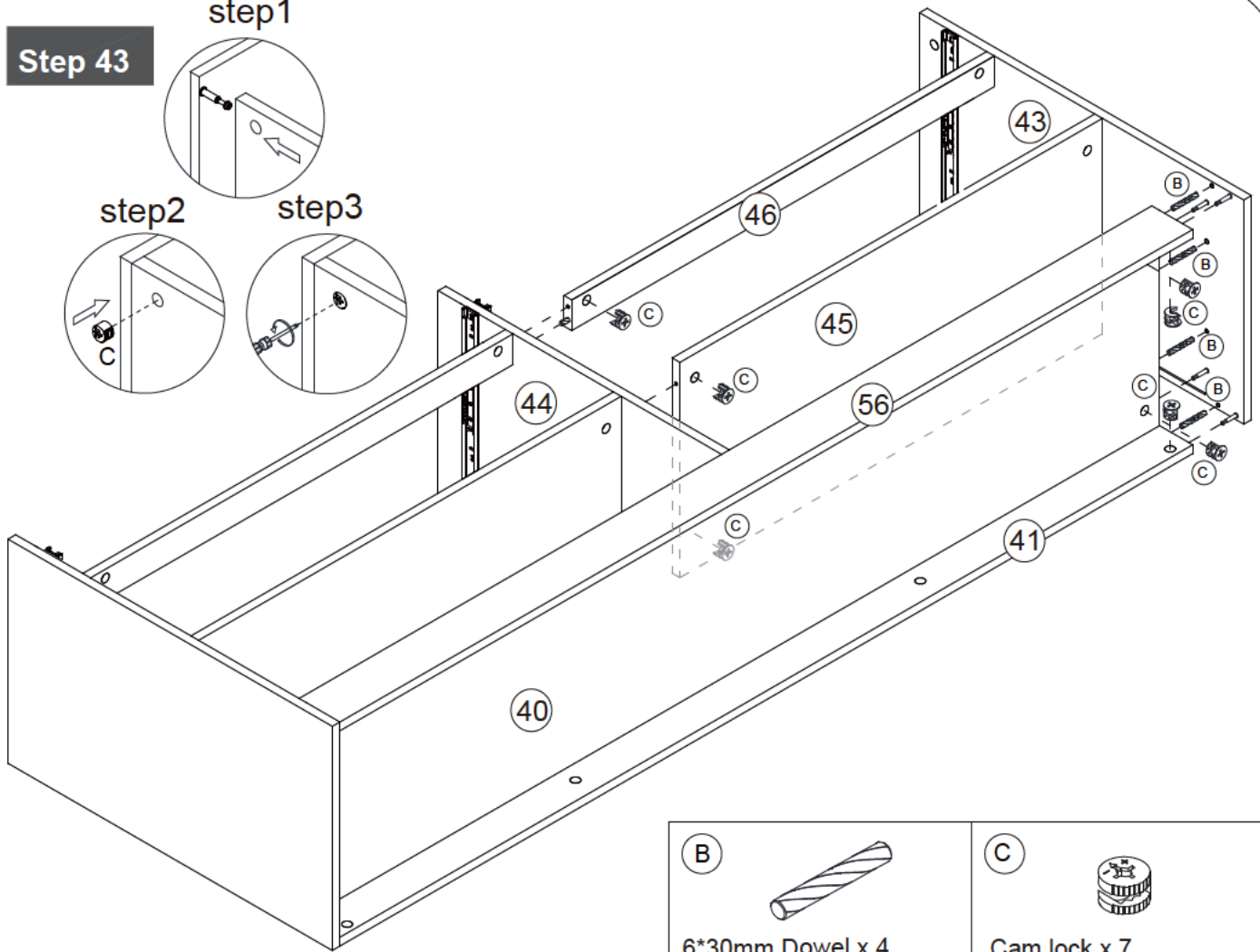
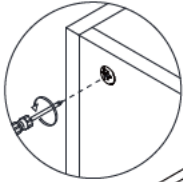

(B)



6*30mm Dowel x 4

(C)



Cam lock x 7

Step 44

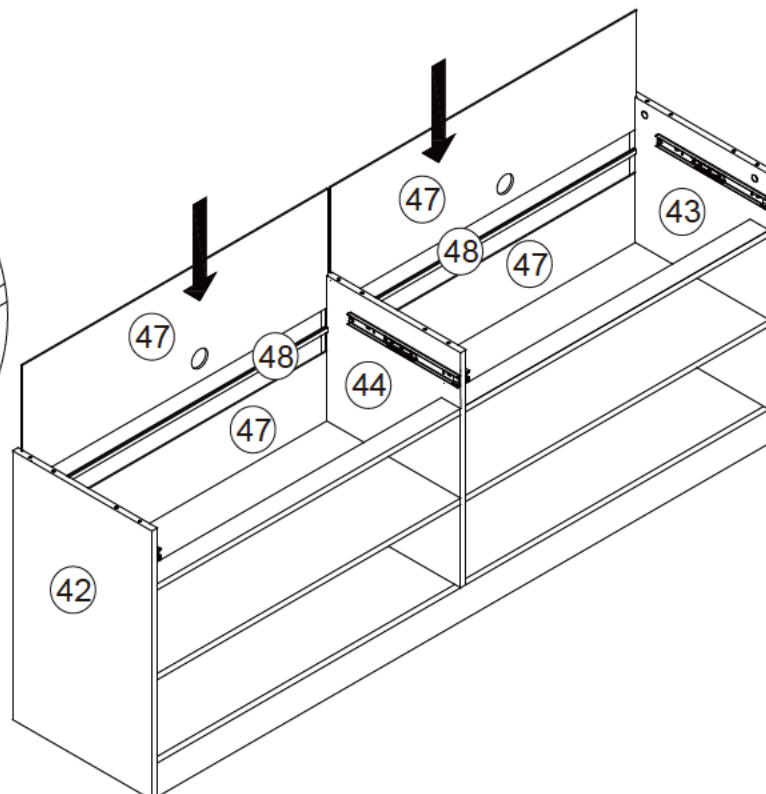
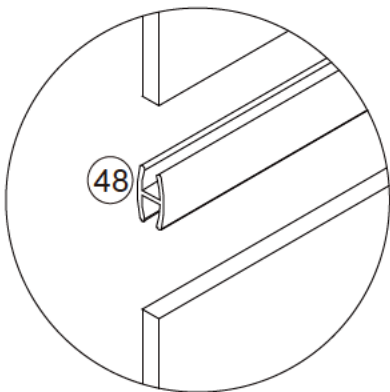

Assembly Instructions

Step 45

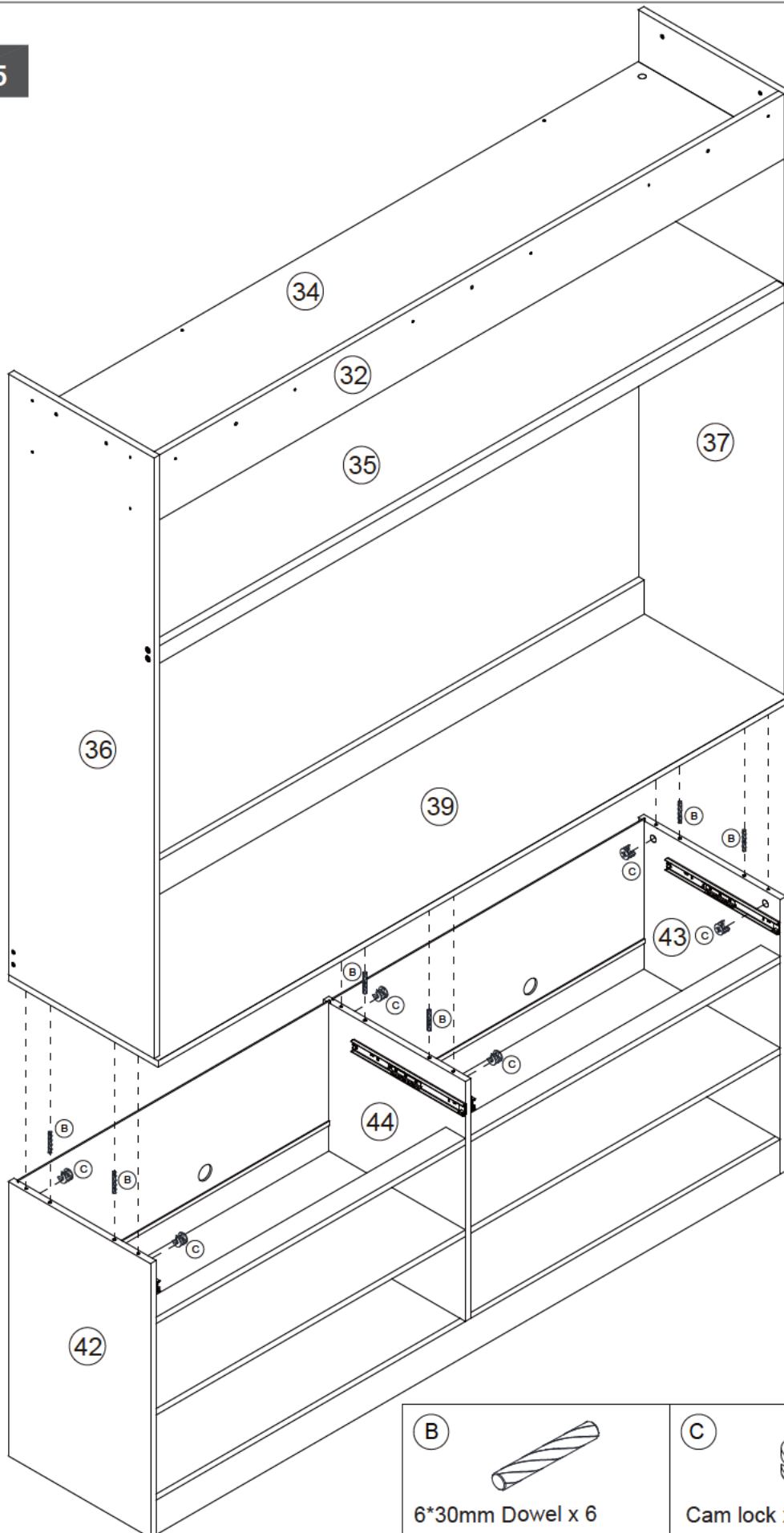

step1

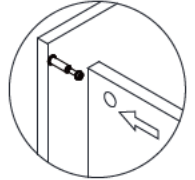

step2

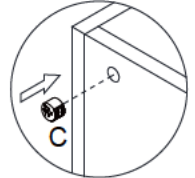

step3

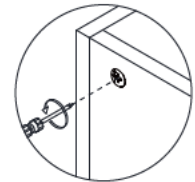

B



6*30mm Dowel x 6

C



Cam lock x 6

35

Assembly Instructions

Step 46

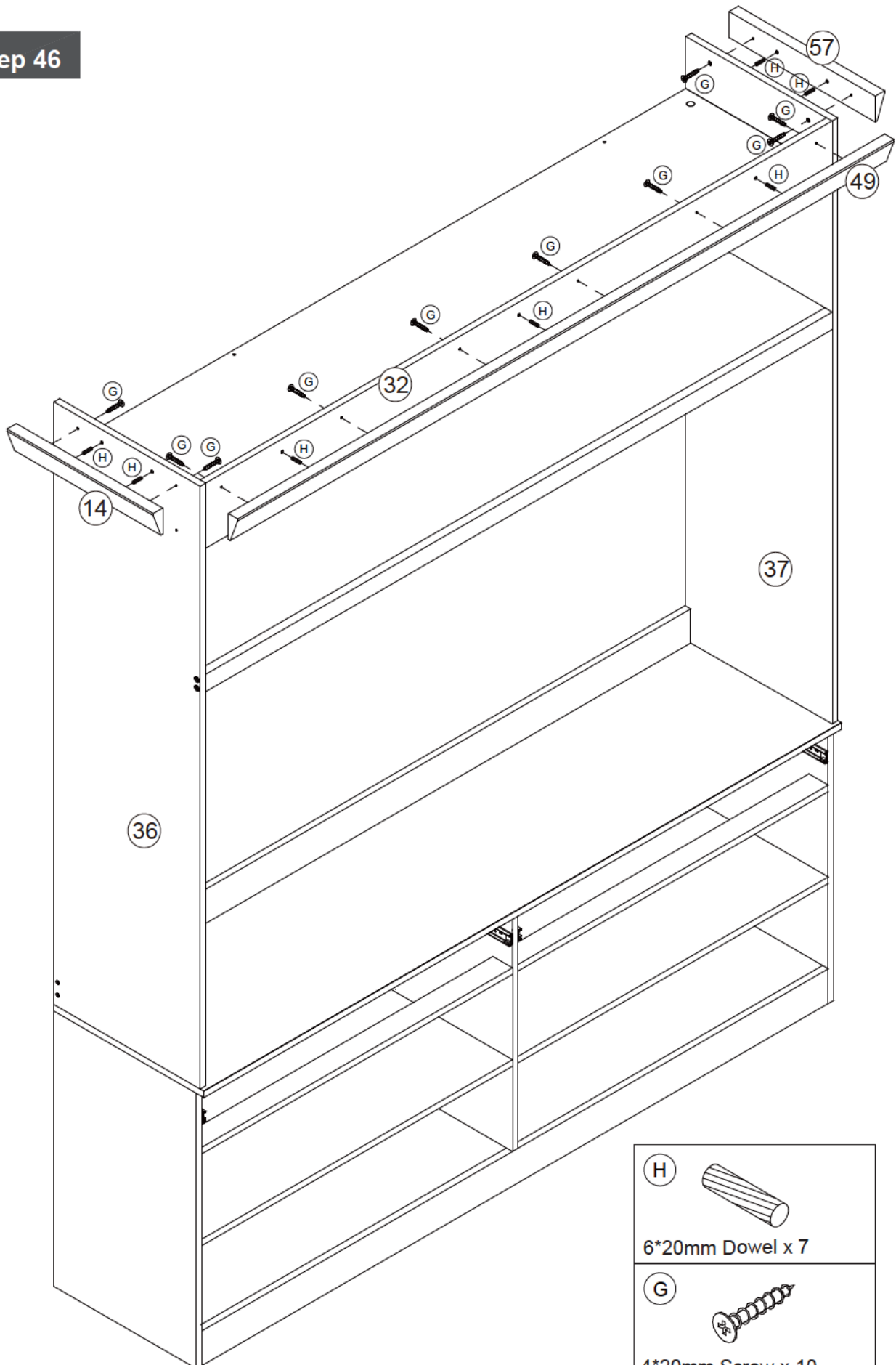

Assembly Instructions

Step 47

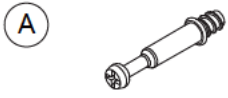
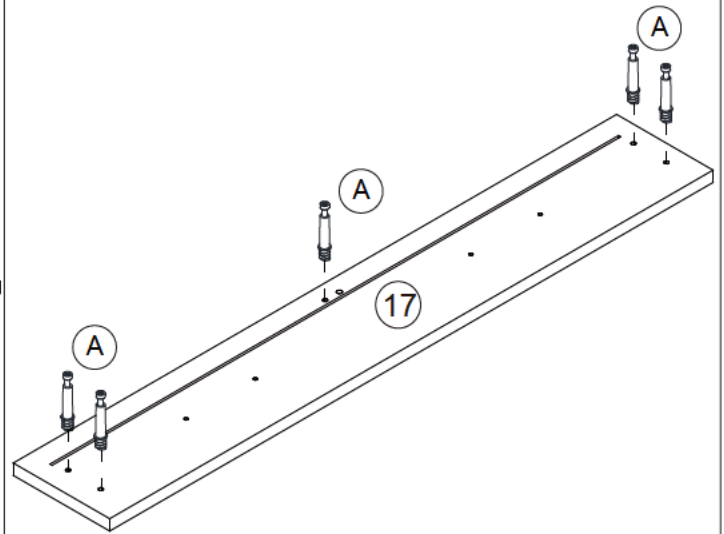
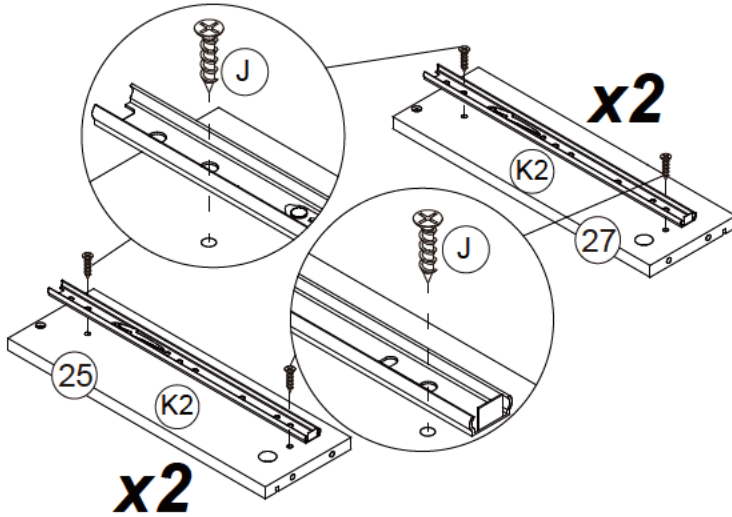

A Cam Bolt x 5



J 3*12mm Screw x 8



K2 Slide x 4

Step 48

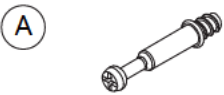
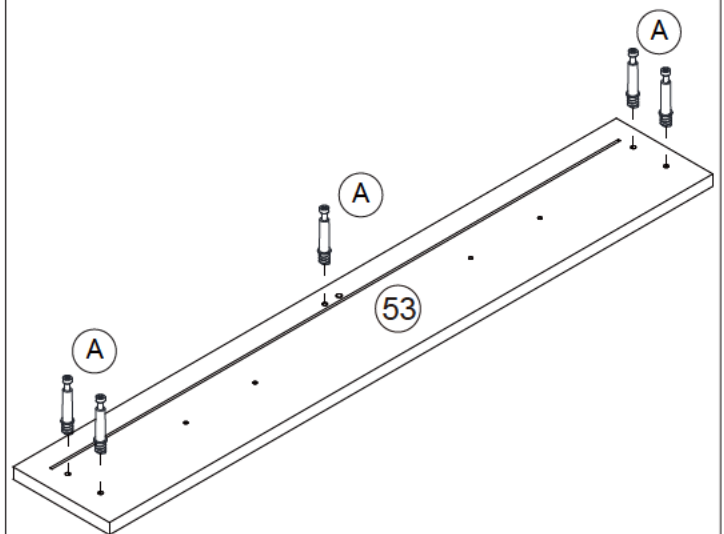
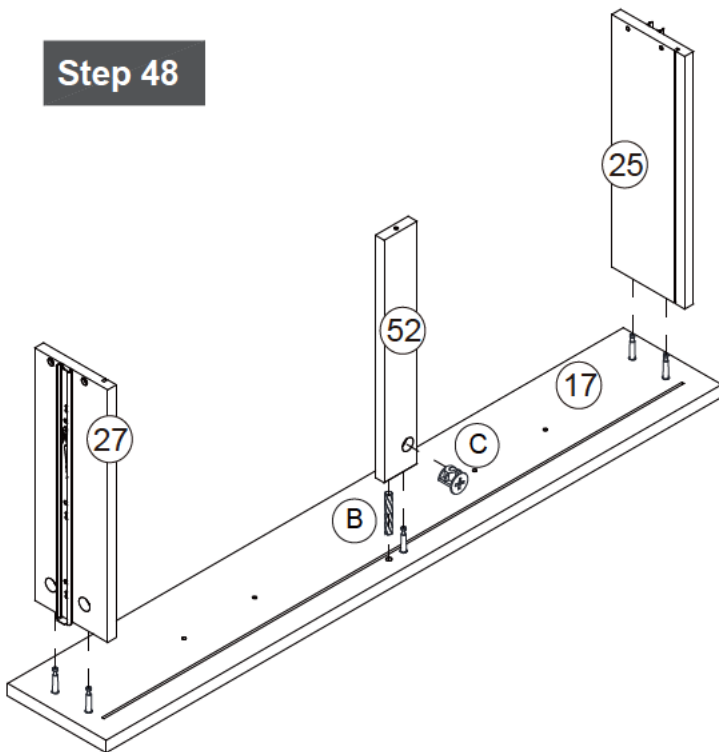

A Cam Bolt x 5



B 6*30mm Dowel x 1



C Cam lock x 1

Assembly Instructions

Step 49

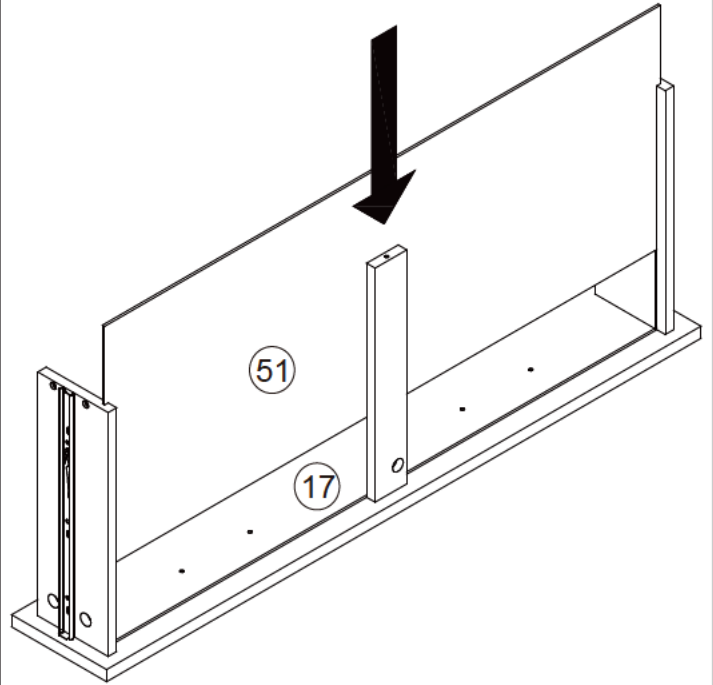
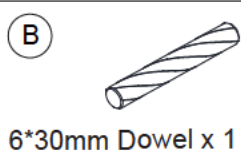
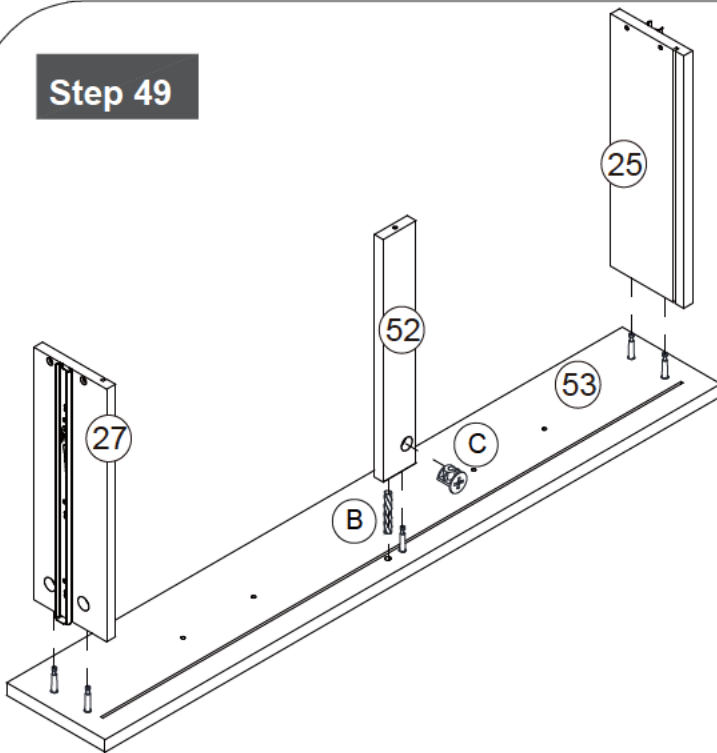

Step 50

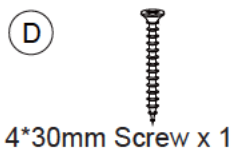
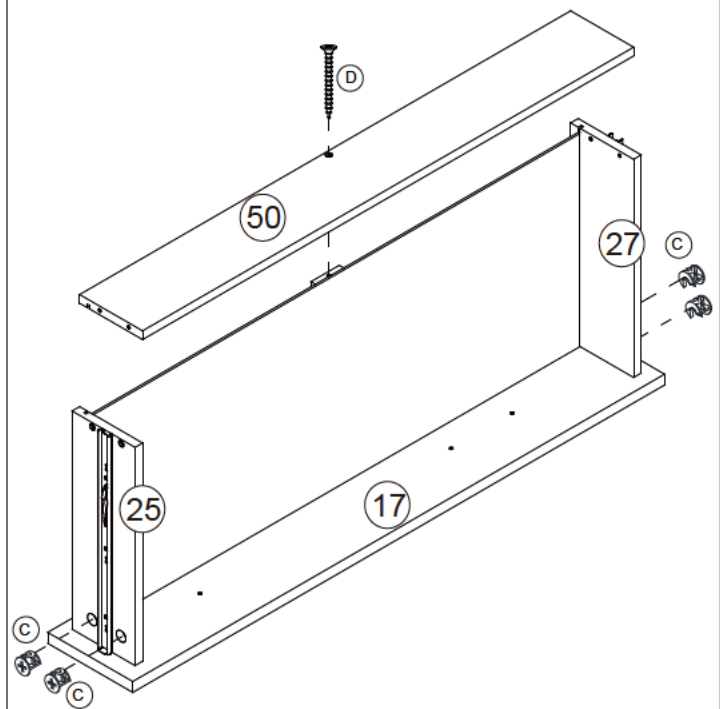
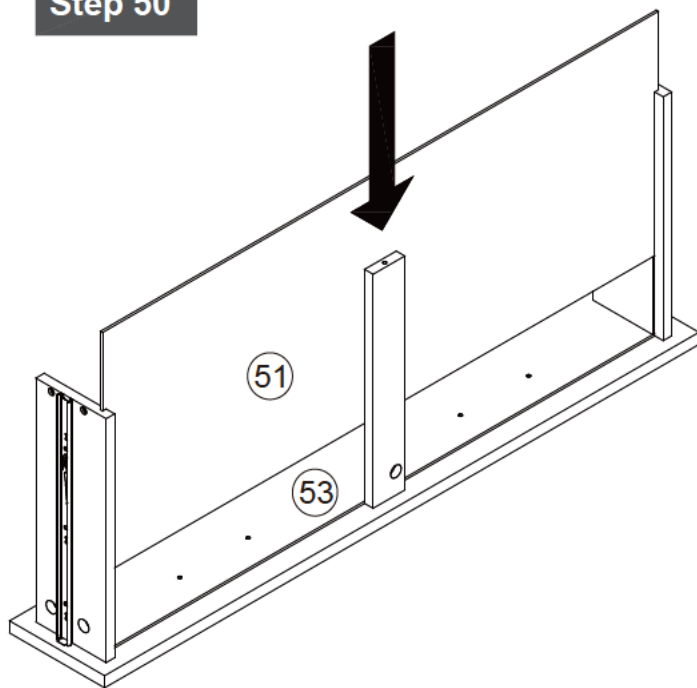

Assembly Instructions

Step 51

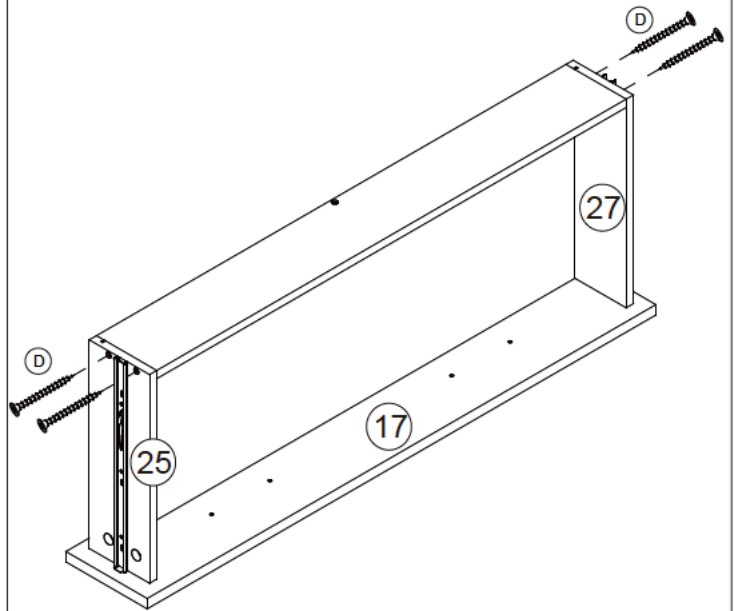
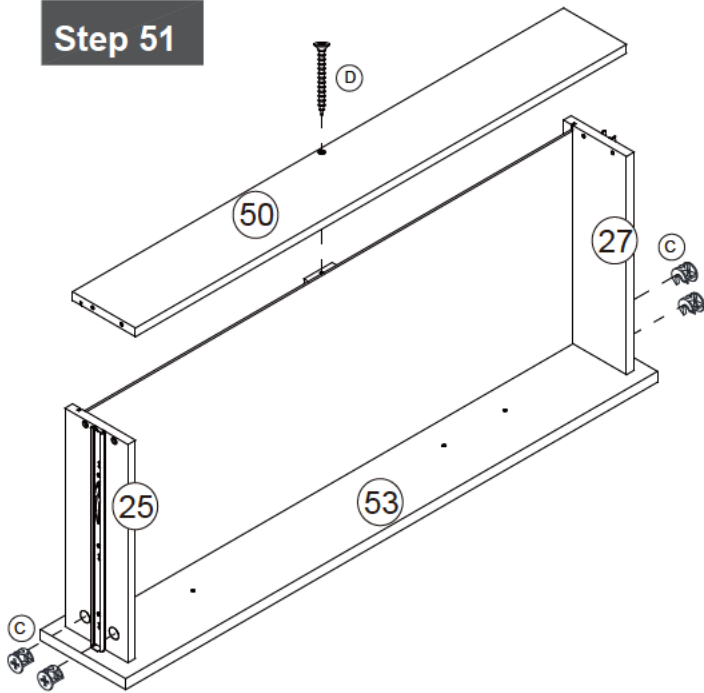

Cam lock x 4



4*30mm Screw x 5

Step 52

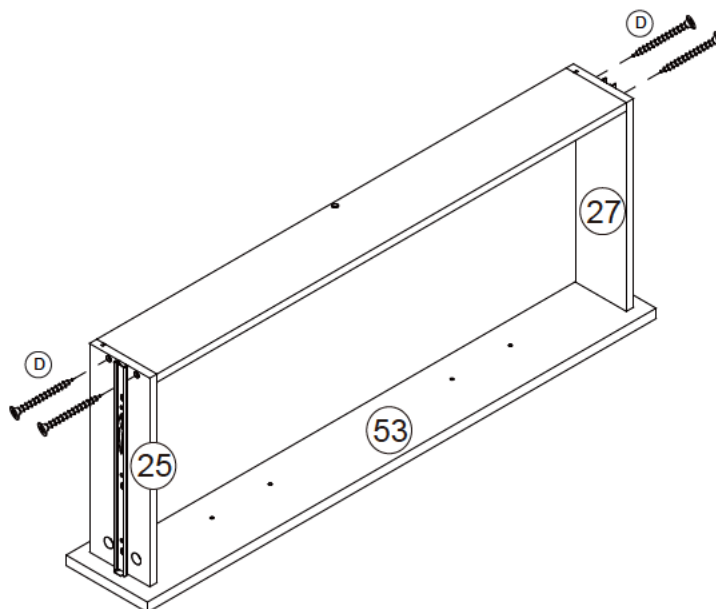

4*30mm Screw x 4

Assembly Instructions

Step 53

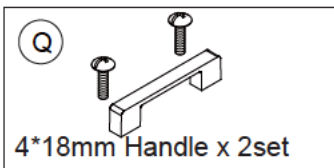
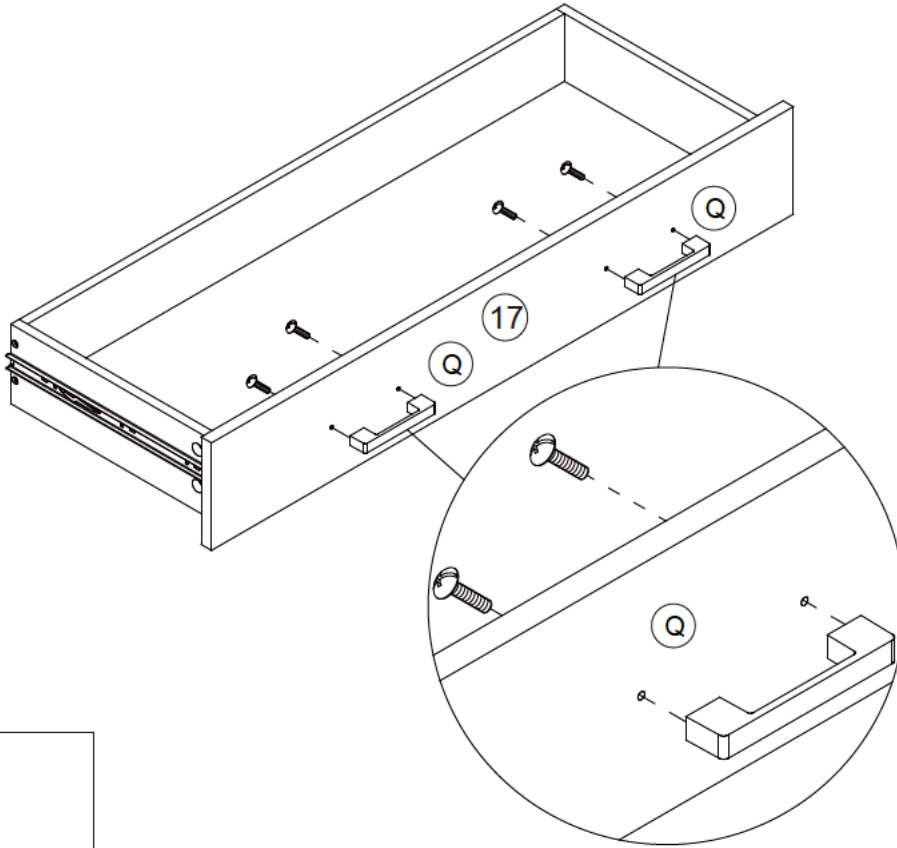

Step 54

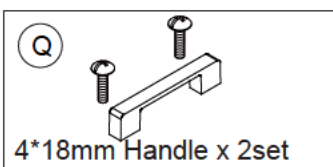
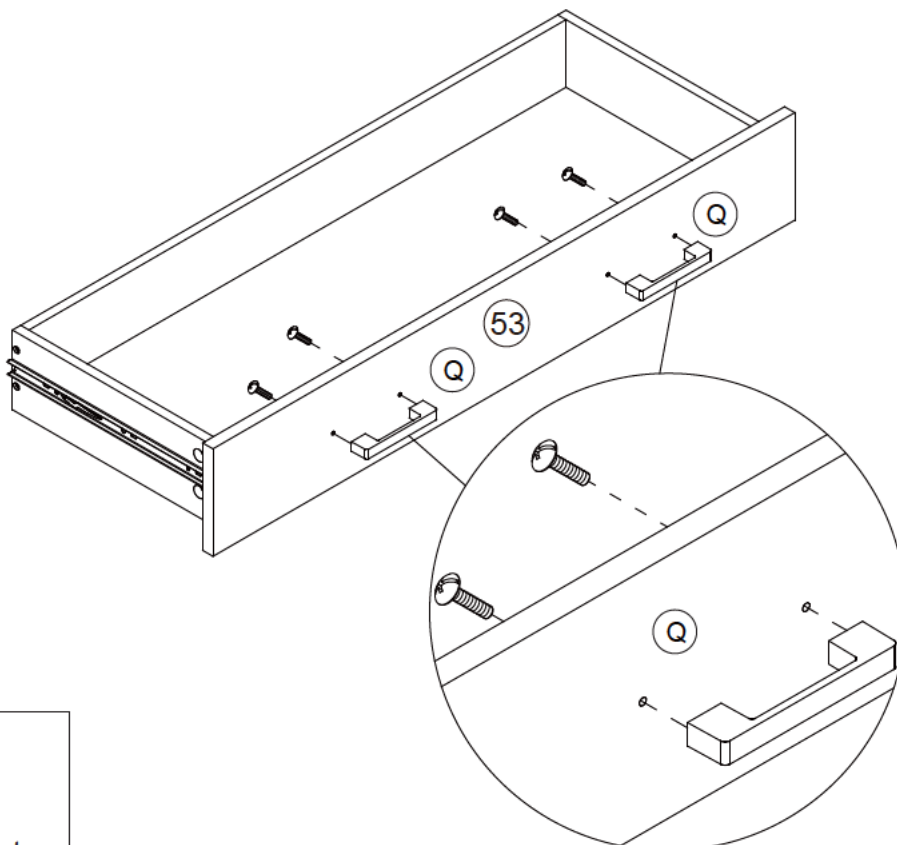

Assembly Instructions

Step 55

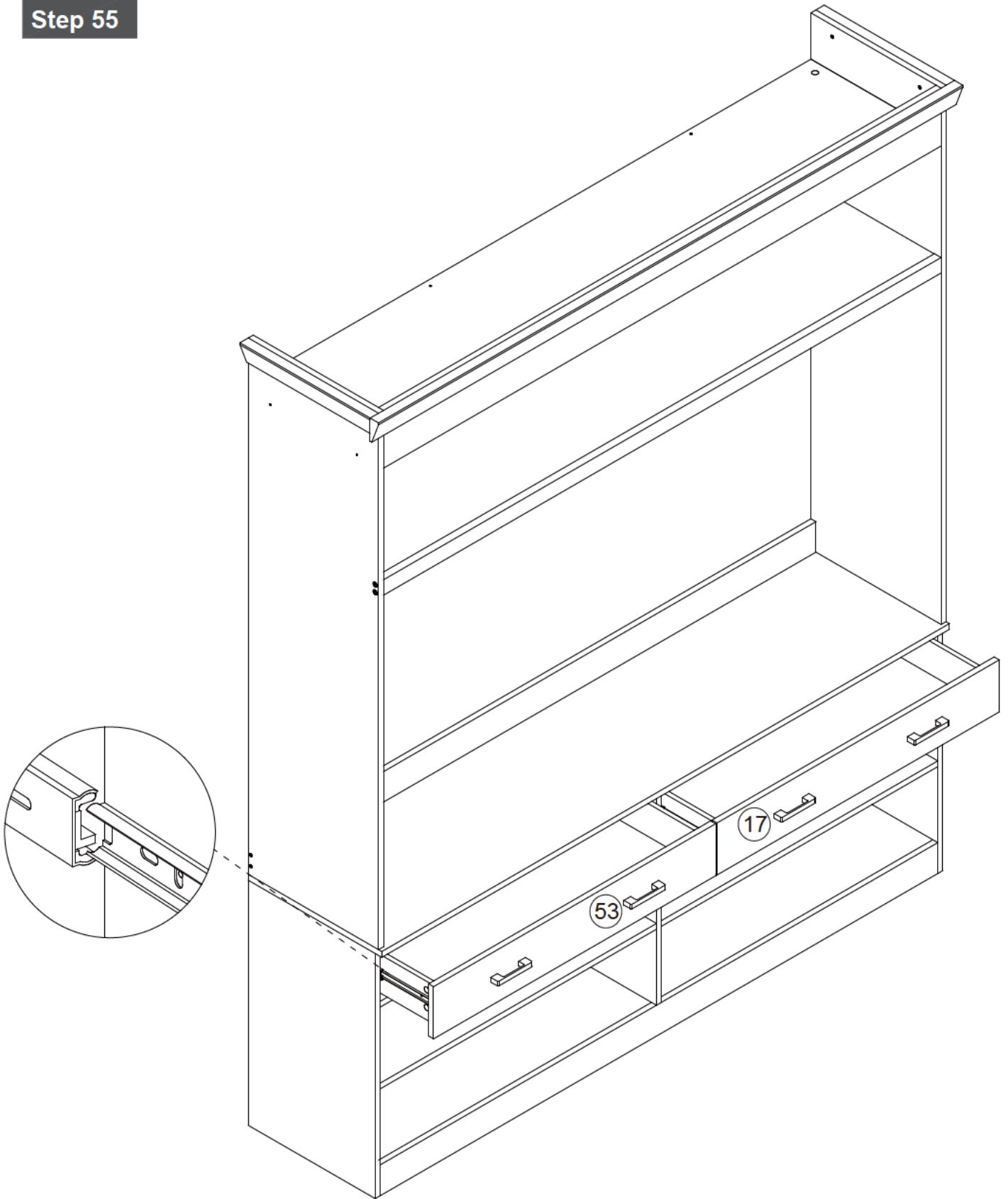

Assembly Instructions

Step 56

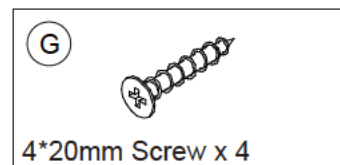
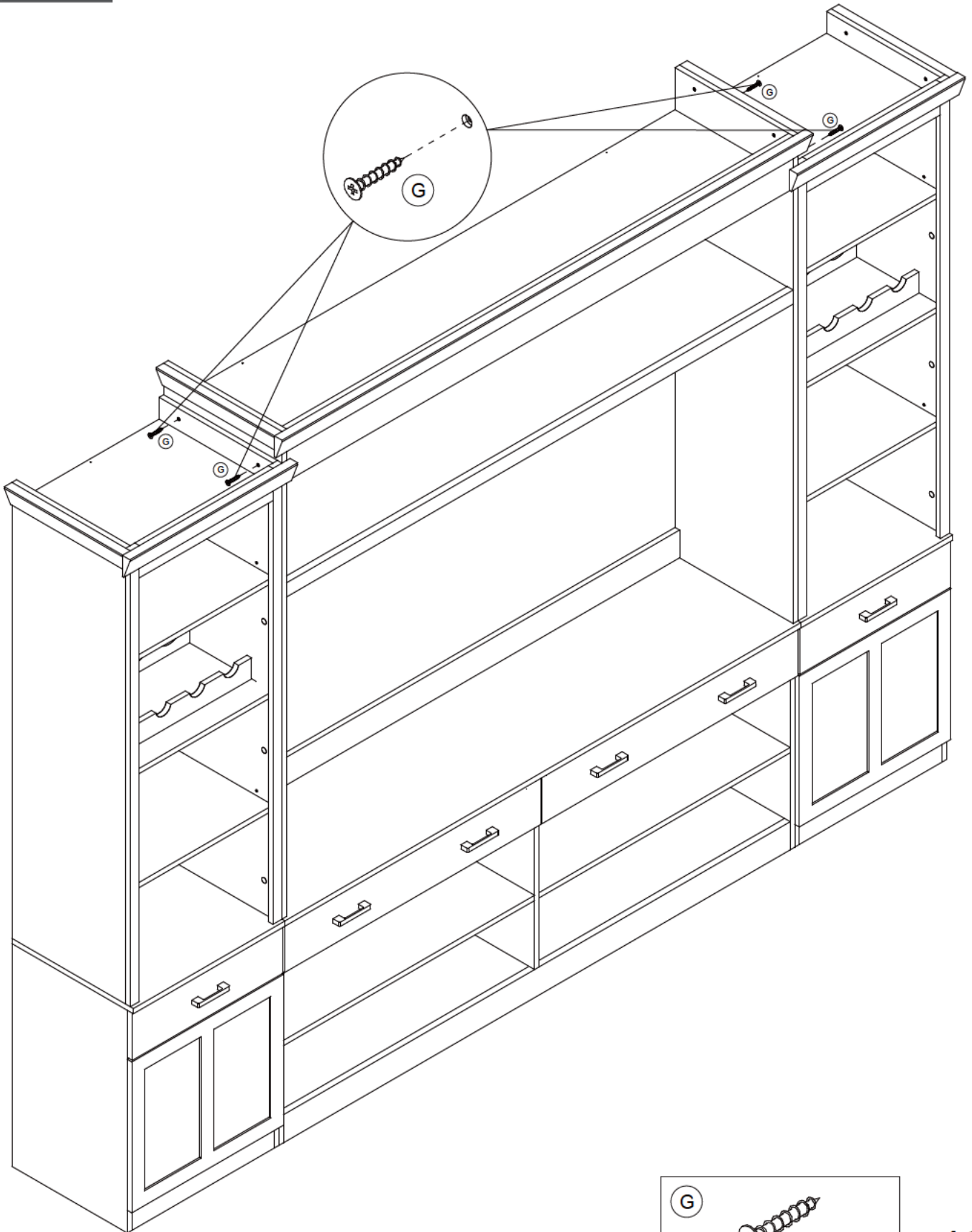

Assembly Instructions

Step 57

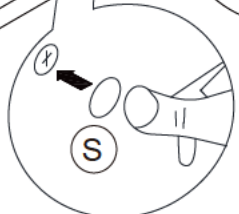
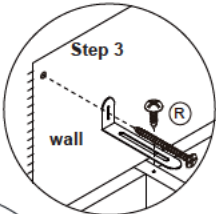
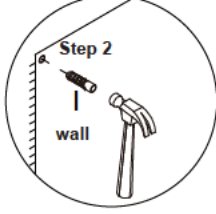
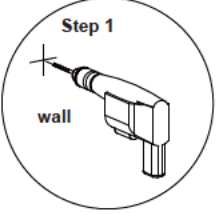
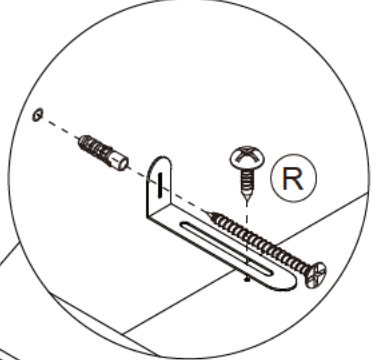
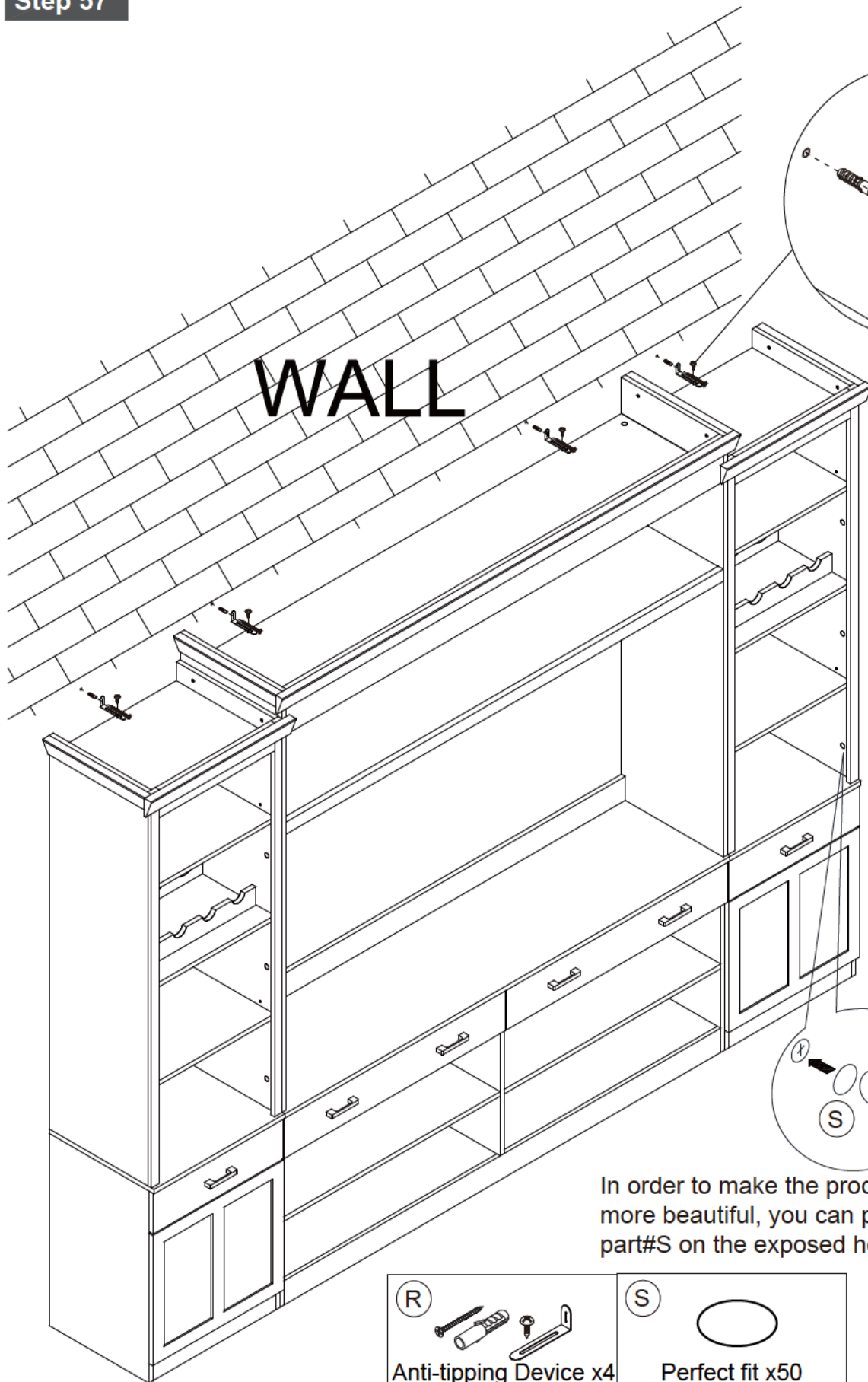

In order to make the product more beautiful, you can paste part#S on the exposed holes



Assembly Instructions

Step 58

