

# ASSEMBLY INSTRUCTION

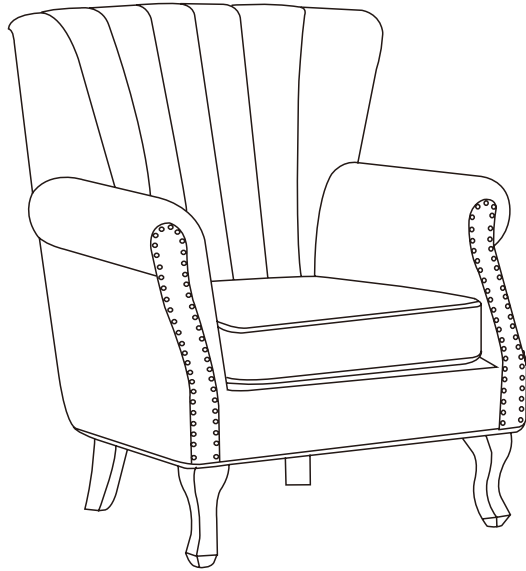

## Component List

| LABEL |  | DESCRIPTION | QTY |
|-------|--|-------------|-----|
| A     |  | Chair Back  | 1   |
| B     |  | Chair Seat  | 1   |
| C     |  | Front Legs  | 2   |
| D     |  | Rear Legs   | 2   |

## Hardware List

| LABEL |  | DESCRIPTION      | QTY |
|-------|--|------------------|-----|
| H1    |  | Bolts<br>M6*20MM | 14  |
| H5    |  | Allen Key<br>M5  | 1   |
| H6    |  | Felt Pad         | 4   |

## Assembly Steps

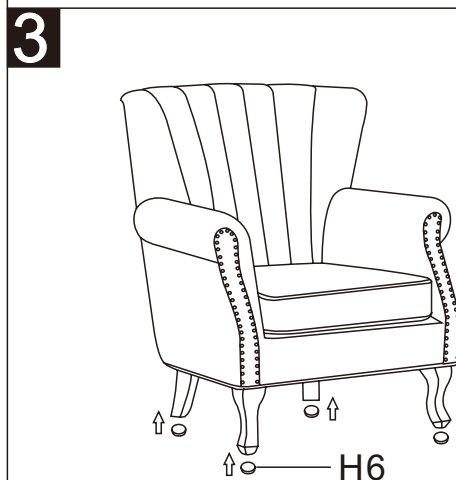
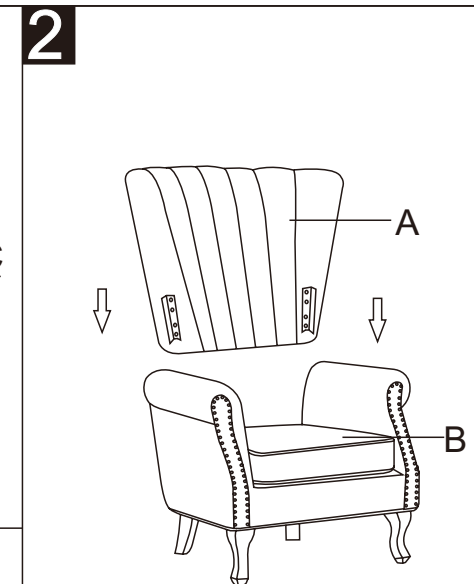
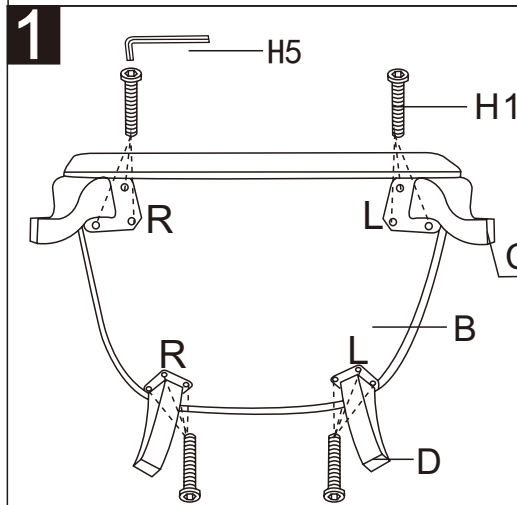

- Align the pre-installed v-brackets on the Chair Back(A) with the corresponding brackets on the back edge of Chair Seat(B), the v-brackets will slide down into the receiving brackets once both aligned.
- Press firmly down on Chair Back(A) to secure the Chair Back(A) to Chair Seat(B).