









# ASSEMBLY INSTRUCTIONS

Thank you for purchasing this quality product. be sure to check all packaging material carefully for small parts that may have come loose inside the carton during shipment.

**"Hardware is attached underneath the seat bottom"**





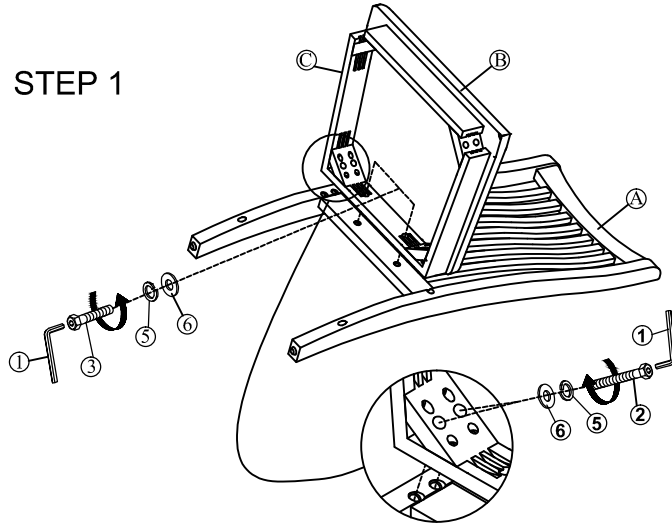

## Components List :

NO.	DESCRIPTION	Q' TY
A	 Back Rest	1pc
B	 Seat Cushion	1pc
C	 Seat Frame	1pc
D	 Front Leg (Left)	1pc
E	 Front Leg (Right)	1pc
F	 Side stretcher (Left)	1pc
G	 Side stretcher (Right)	1pc
H	 Plastic Glides	4pc

## STEP 1



## Hardware List :

NO.	DESCRIPTION	SIZE	SKETCH	Q' TY
1	Allen Key	4mm		1pc
2	Allen Bolts	5/16"*3-1/8"		4pcs
3	Allen Bolts	5/16"*1-9/16"		2pcs
4	Allen Bolts	5/16"*2"		4pcs
5	Spring Washer	(8mm)		10pcs
6	flat Washer	(8*19*2mm)		10pcs
7	Wood Screw	#8*2"		4pcs

## STEP 2

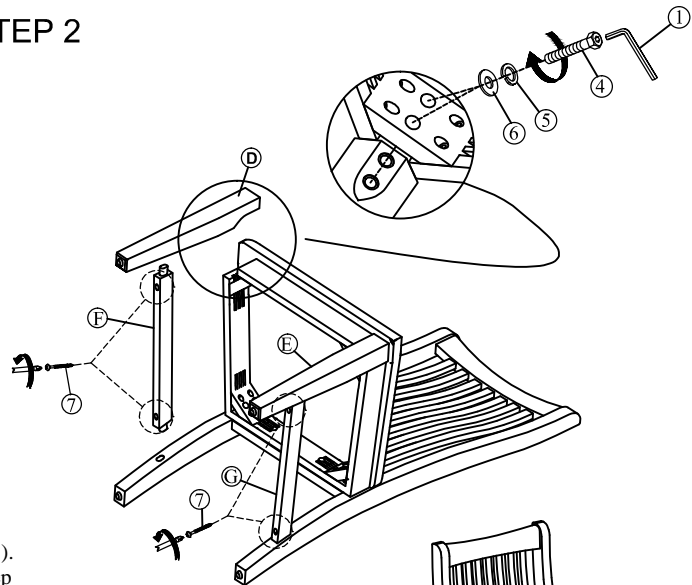

## Reminder

1. Use only the hardware supplied
2. Once the chair finished, leveled and tighten all bolts.
3. Do not over-tighten the bolts.
4. This item may require periodic tightening

## NOTE:

1. Hardware pack is located underneath the Seat Cushion (B).
2. Two or more people are needed for assembly. Please Keep all hardware parts out of the reach of children.

**Step 1.1:** Attach the Chair Seat (B&C) to Back Rest (A) by using Flat Washer (6). Spring Washer (5) and Bolt (2&3) secure with Allen Key (1)

**Step 2:** Attach Side Stretcher (F&G) to Back Rest (A) using Wood Screws through pre-drilled holes of Side Stretcher (F&G). Attach the Front Legs (D&E) to the Seat Frame (C) using Flat Washer (6). Spring Washer (5). Bolt (4) tighten with Allen Key (1). Attach Front Legs (D&E) to the Side Stretcher(F&G) using Wood Screws (7) through pre-drilled holes on the Side Stretcher (F&G).

Assembly is now complete

Thank you for purchasing this product.

