

Oceanside Coffee Table
Item #W22130
Assembly Instructions

****TO AVOID POTENTIAL SCRATCHING TO PARTS BY ROUGH GROUND SURFACE, COVER GROUND WITH SOFT SMOOTH PROTECTIVE MATERIAL ON WHICH TO PLACE PARTS DURING ASSEMBLY. ****

Step 1: Remove protective wrapping and lay all parts on floor. Identify all parts packed in carton against the parts list.

Step 2: Lay Table Top Frame (A) upside down on floor, so bottom is facing up. Place a protective soft material on floor before placing table top face down on floor.

Step 3: Attach each of four table legs (B) to the bottom as shown in Diagram 1, using Short Bolt (D) and Washer (F). Then attach Stretcher (C) to Leg (B) using Long Bolt (E) and Washer (F) as shown in Diagram 2. Loosely thread all bolts on first. After all parts are assembled in place, go back to securely tighten all bolts with Hex Wrench(H).

Step 4: After making sure all bolts are aligned properly and tightened sufficiently, place Bolt Covers (G) over bolts. Turn table over to upright position onto flat surface as shown in Diagram 3.

NOTE: IT IS USER'S RESPONSIBILITY TO MAKE SURE ALL PARTS ARE ASSEMBLED AND TIGHTENED PROPERLY AND SECURELY.

WARNING! TABLE IS NOT MEANT FOR SITTING OR STANDING ON. DO NOT SIT / STAND ON OR LEAN FULL BODY AGAINST TABLE. IMPROPER USE MAY LEAD TO PRODUCT DAMAGE AND/OR BODILY INJURY.

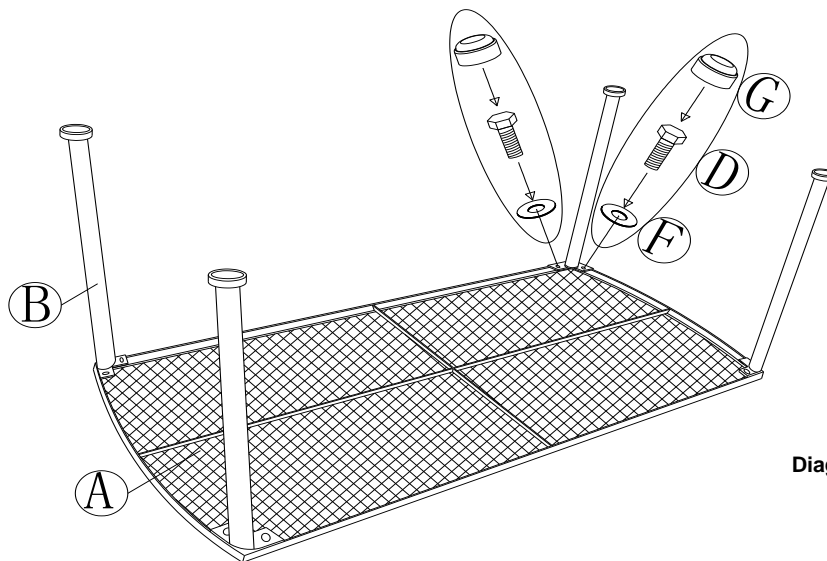

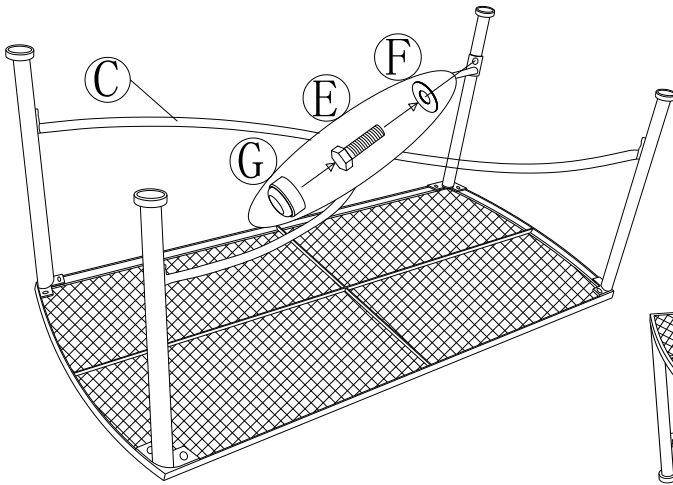

Diagram 2

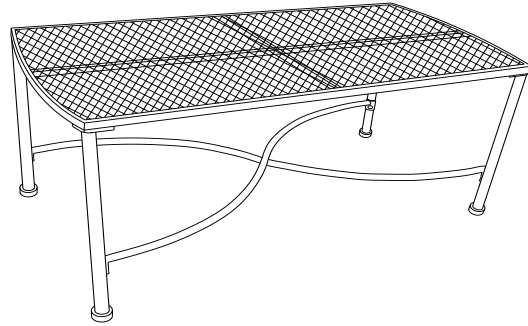
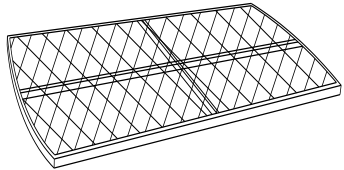
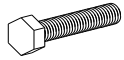

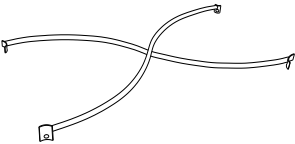

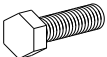
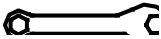

Diagram 3

PARTS LIST

Ref	Part Name	Part Image	Qty	Ref	Part Name	Part Image	Qty
A	Table Top		1	E	Long Bolt		4
B	Table Legs		4	F	Washer		12
C	Stretcher		1	G	Bolt Cover		12
D	Short Bolt		8	H	Hex Wrench		1

WOODARD
Customer Service Hours
8:00am-5:00pm CST Monday to Friday
Phone: (800) 877-2290 Fax: (800) 733-4257
E-mail: retail3@woodard-furniture.com