

Use the following for assembly:

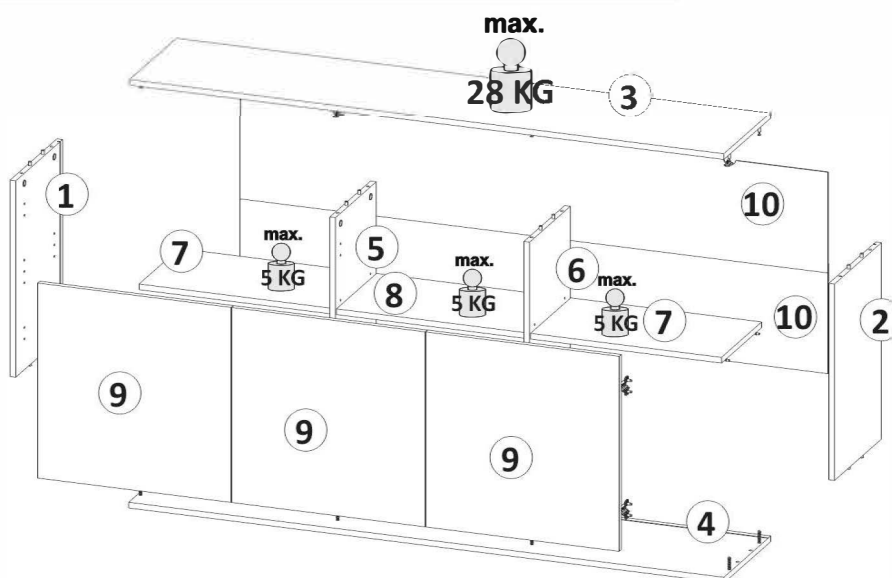

BAG 1

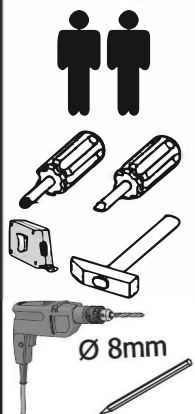
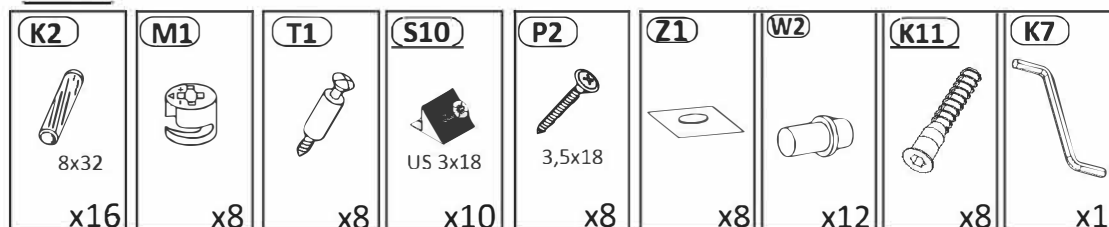

BAG 2

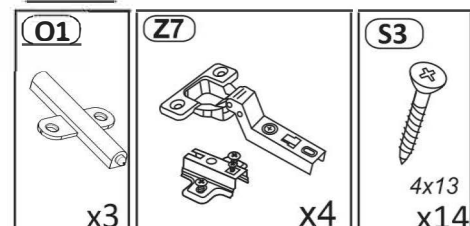

BAG 3

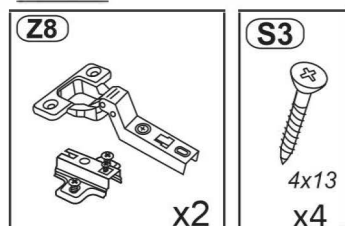

BAG 4

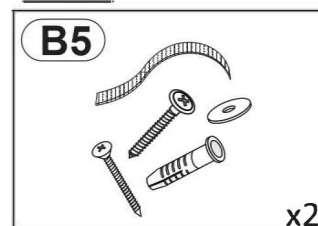

nr. Elementu no. of element	ilość quantity	wymiar w mm		
		długość length	szerokość width	grubość thickness
1	1	550	350	16
2	1	550	350	16
3	1	1680	350	16
4	1	1680	350	16
5	1	550	304	16
6	1	550	304	16
7	2	539	300	16
8	1	530	300	16
9	3	546	546	16
10	1	1660	282	3
	1	1660	282	3

Przed rozpoczęciem montażu proszę sprawdzić wymiary głównych elementów mebla. Pozwoli to na uniknięcie pomyłek i ułatwi cały proces.

Before starting the assembly, please check the dimensions of the main elements of the unit. This will avoid mistakes and make the whole process convenience.

Bevor Sie mit der Montage beginnen, überprüfen Sie bitte die Abmessungen der Hauptelemente der Möbel. Dadurch werden Fehler vermieden und der gesamte Prozess vereinfacht

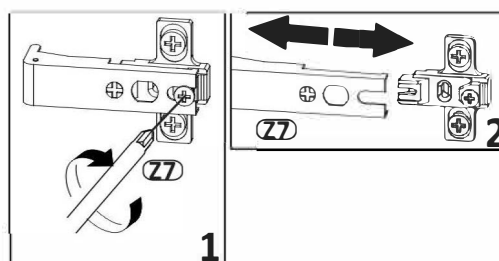

1

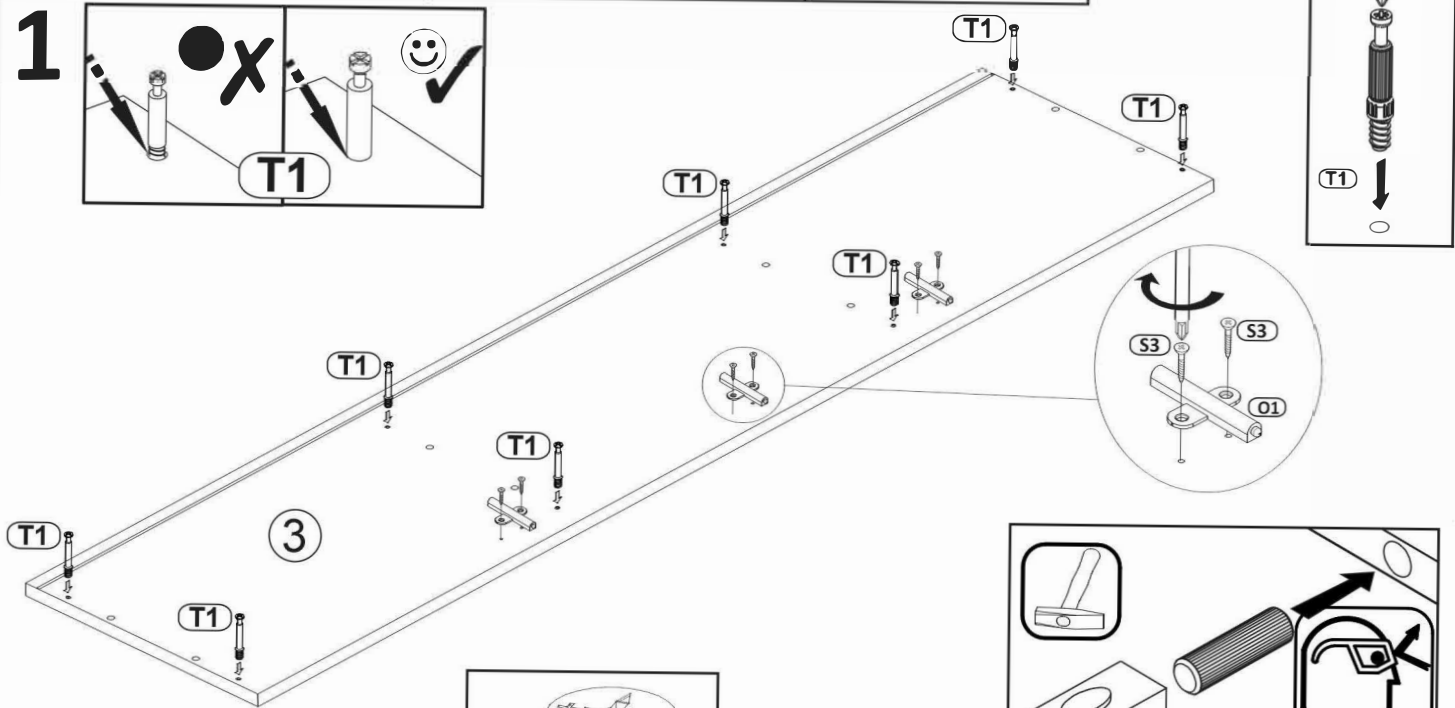
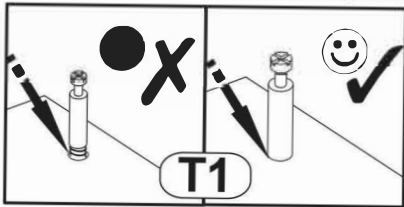

3

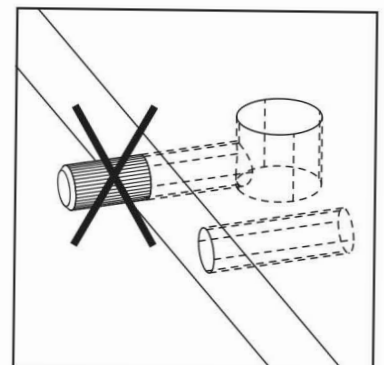
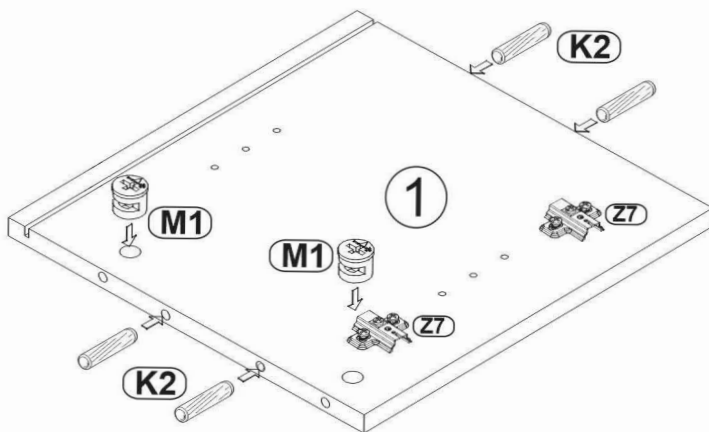
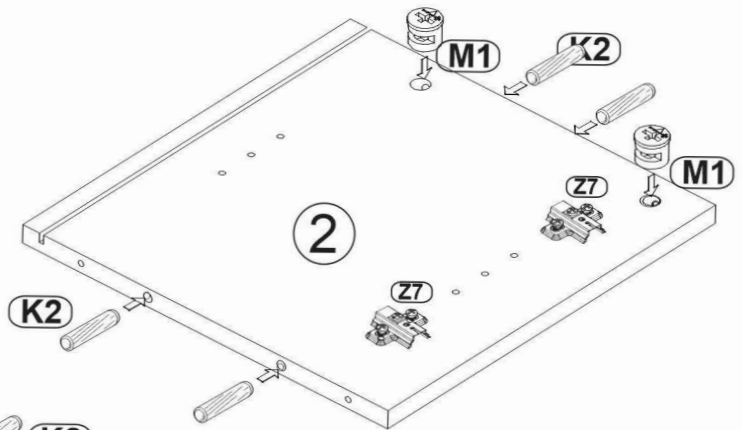
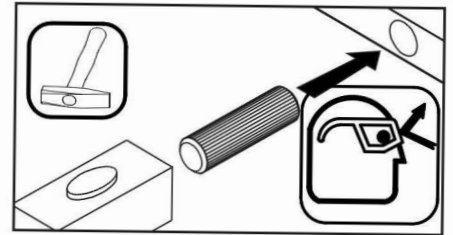
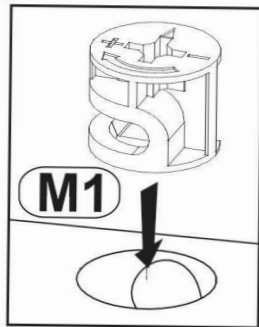
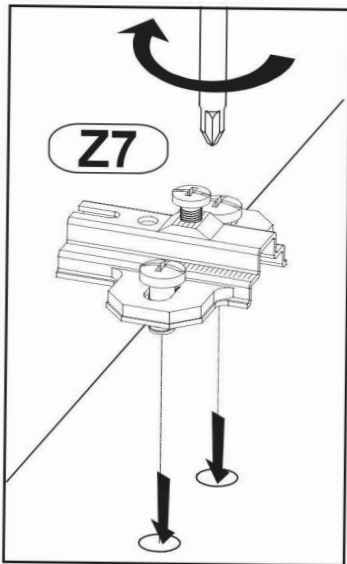

2

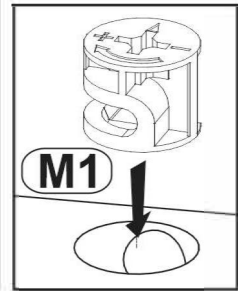
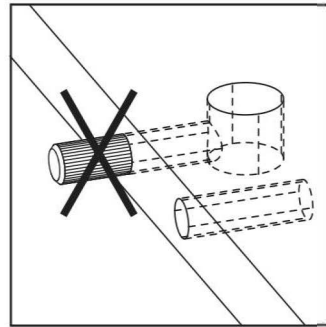
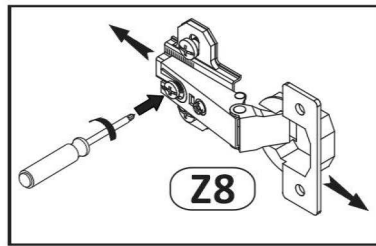
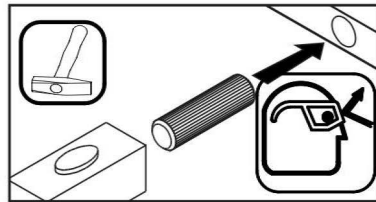
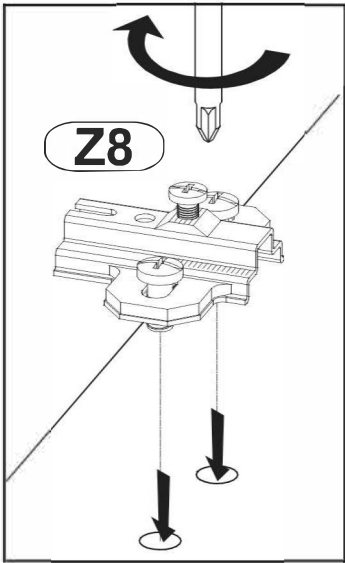
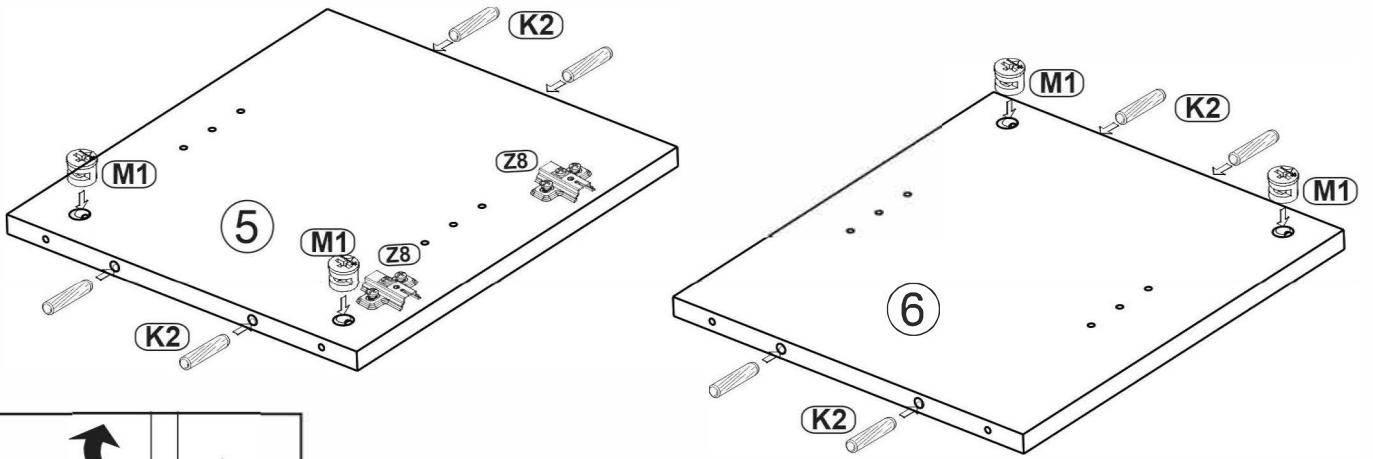

3

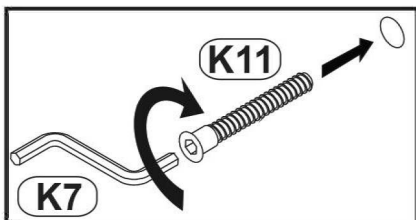
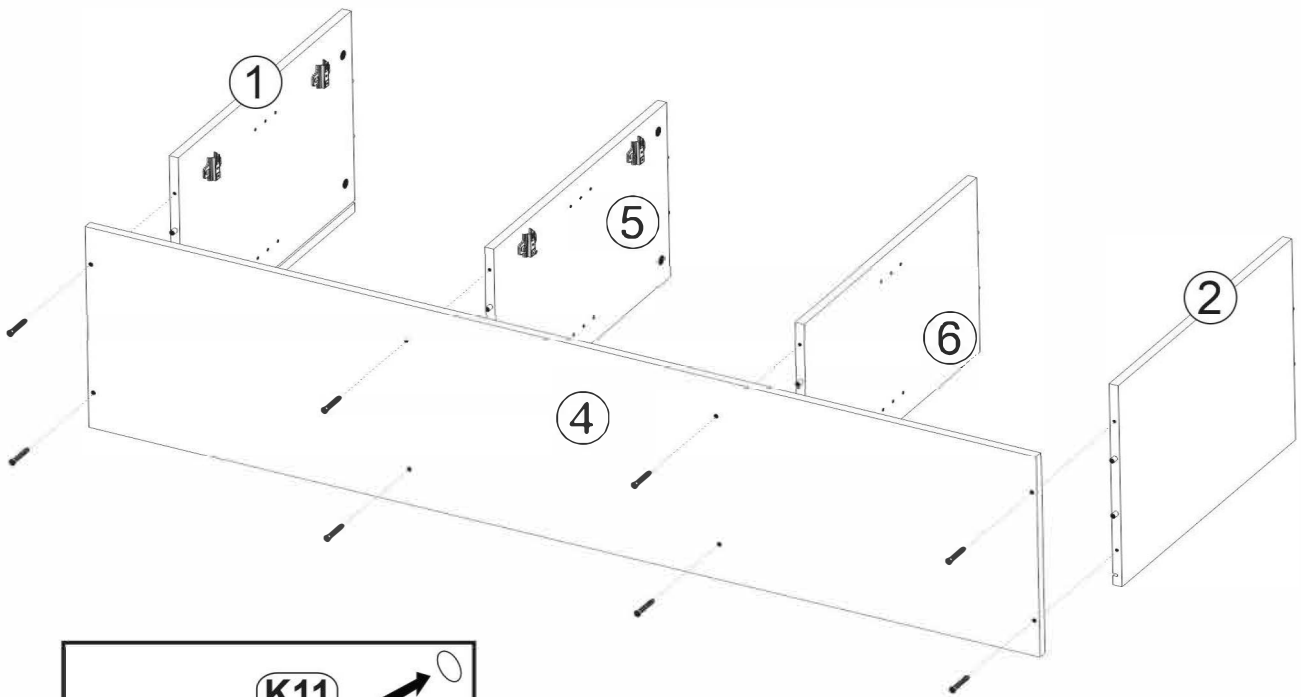

4

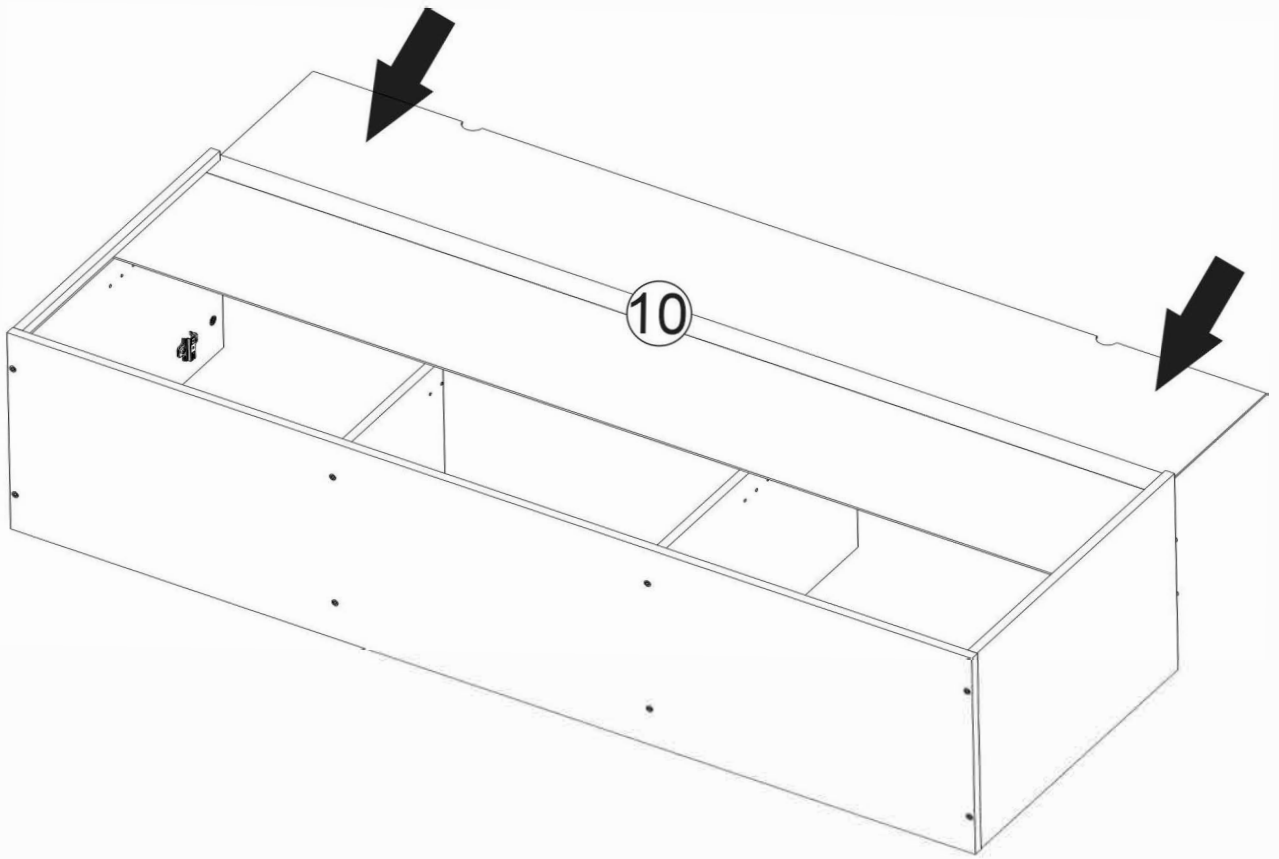

5

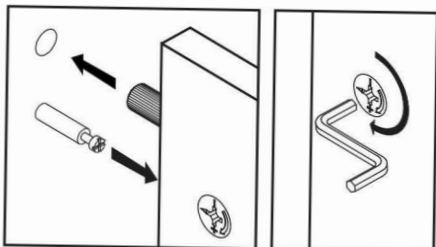
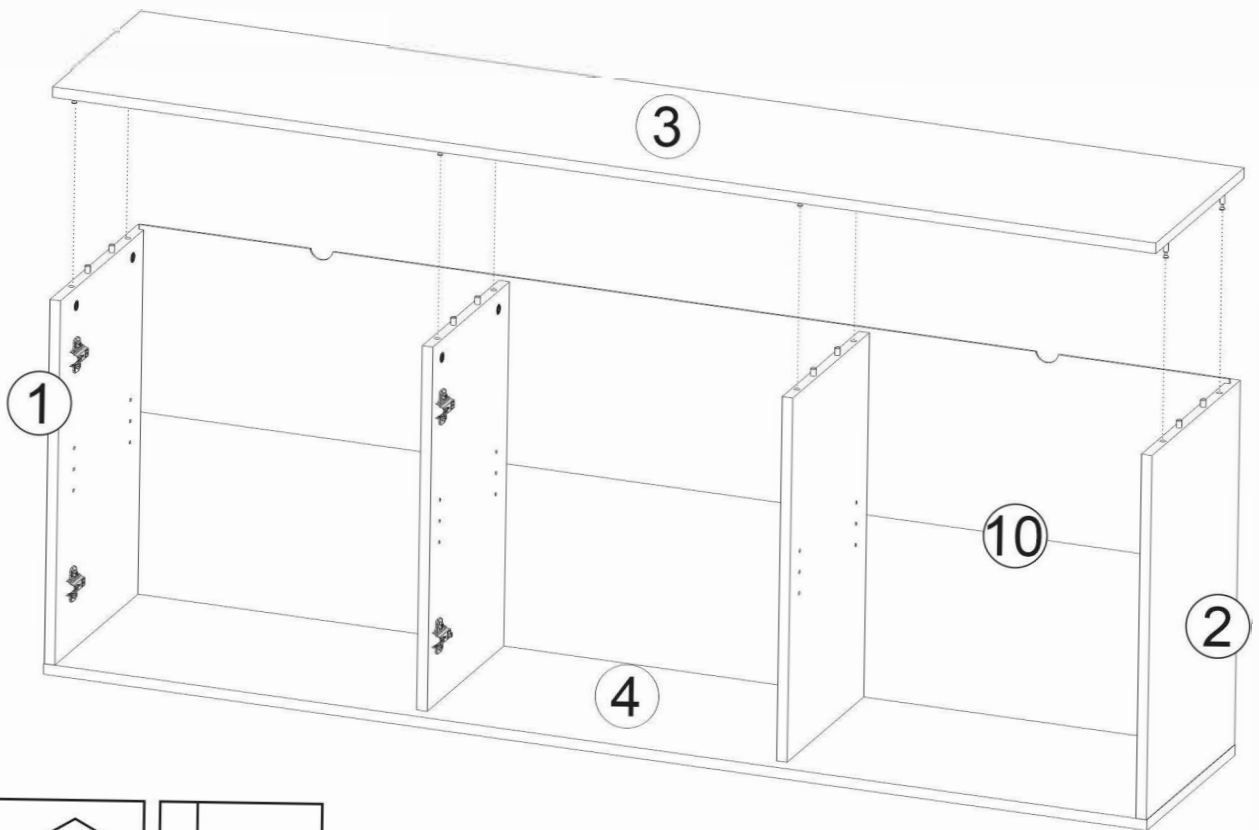

6

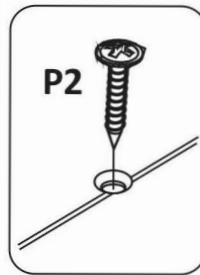
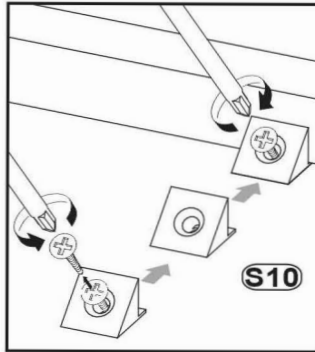
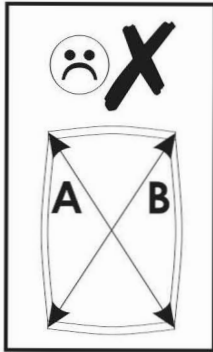
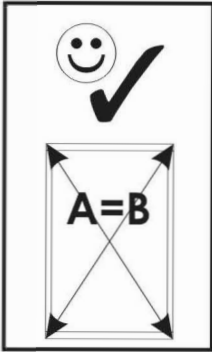
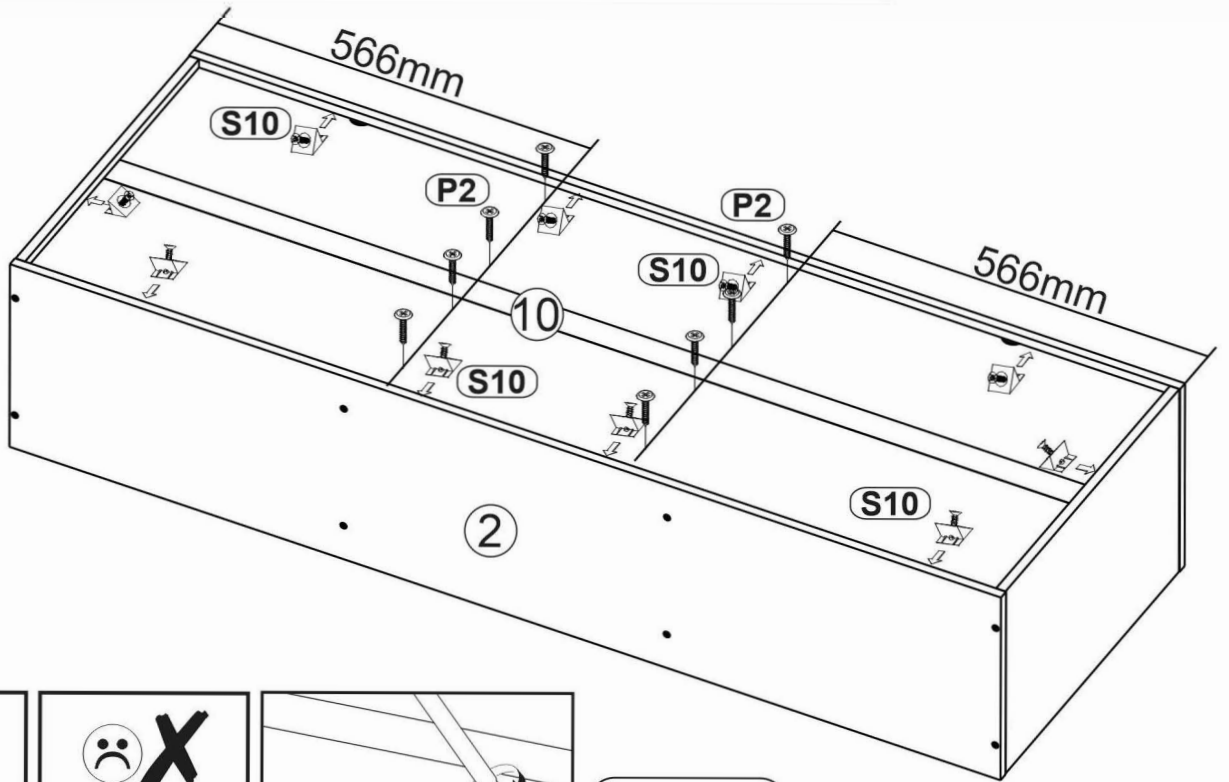

7

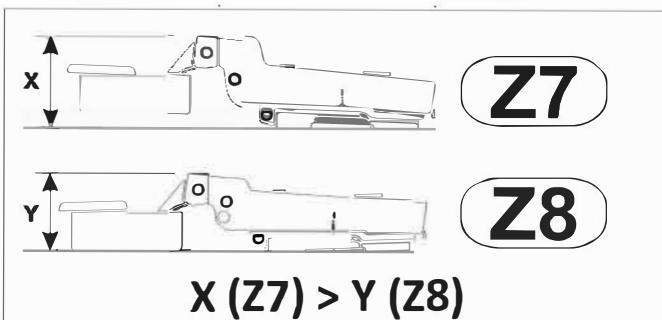
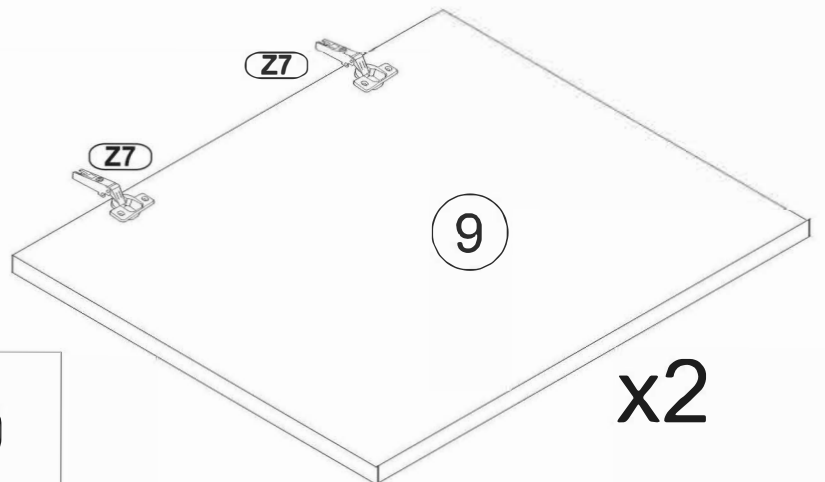
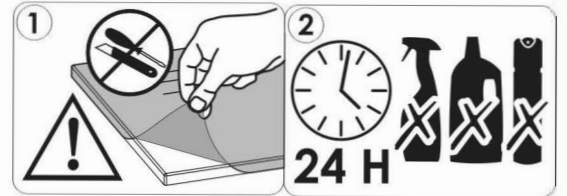
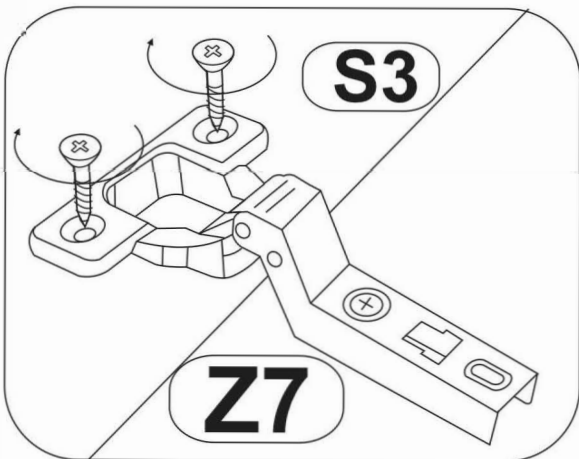

8

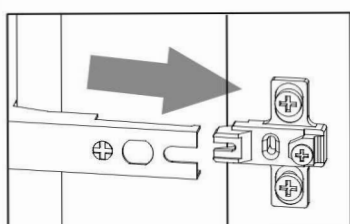
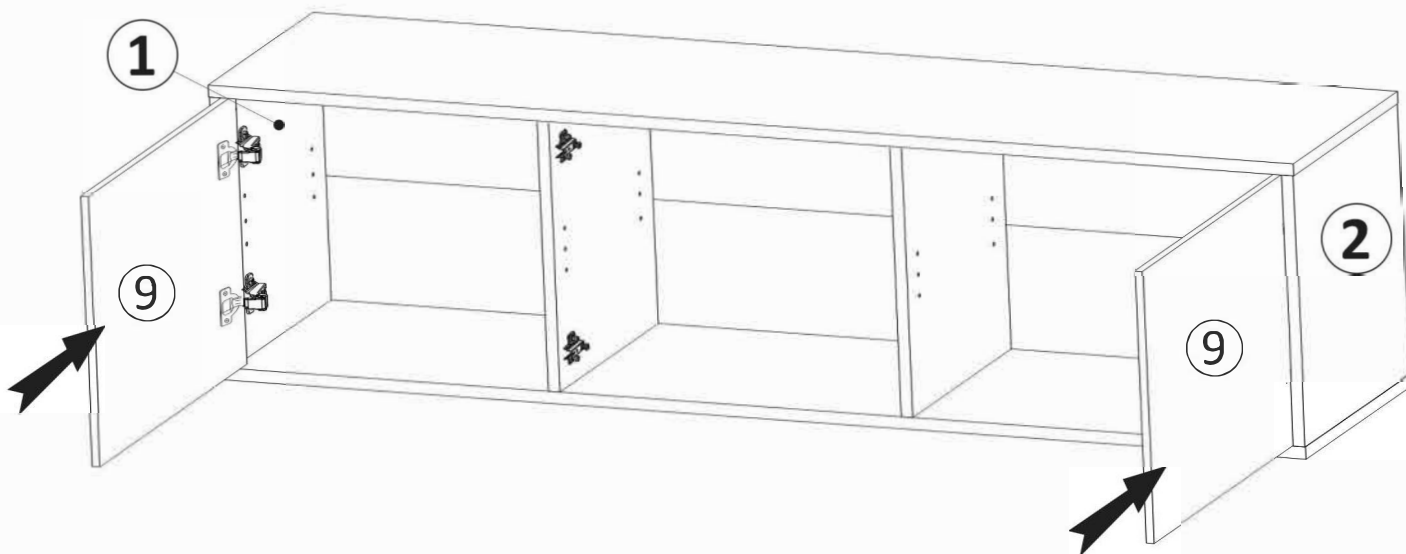

9

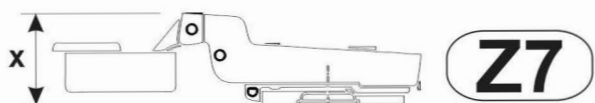
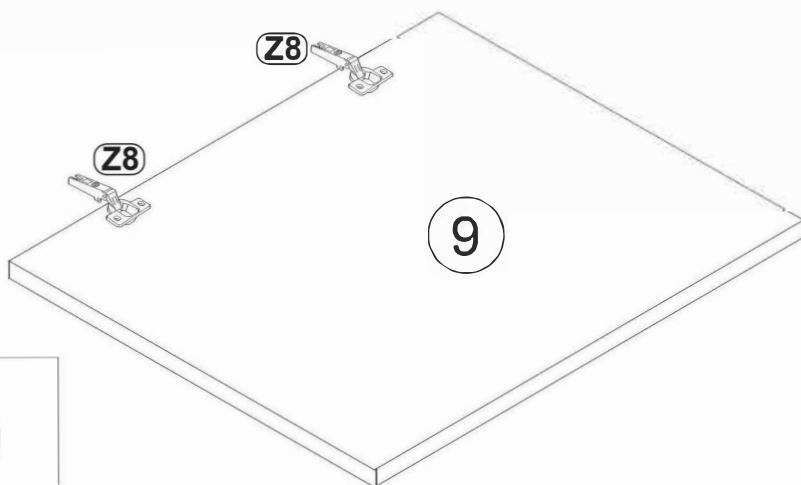
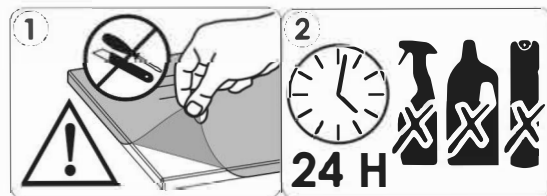
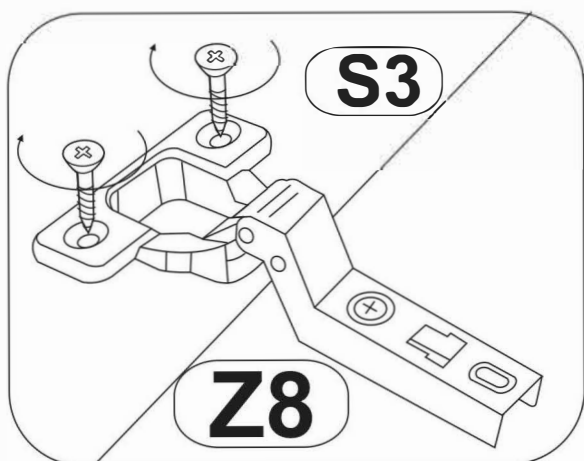

$X (Z7) > Y (Z8)$

Model:
Modell:

Typ:
Type: **CABINET 3D**

Strona:
Blatt Nr: **7/7**

10

