

ASSEMBLY INSTRUCTIONS

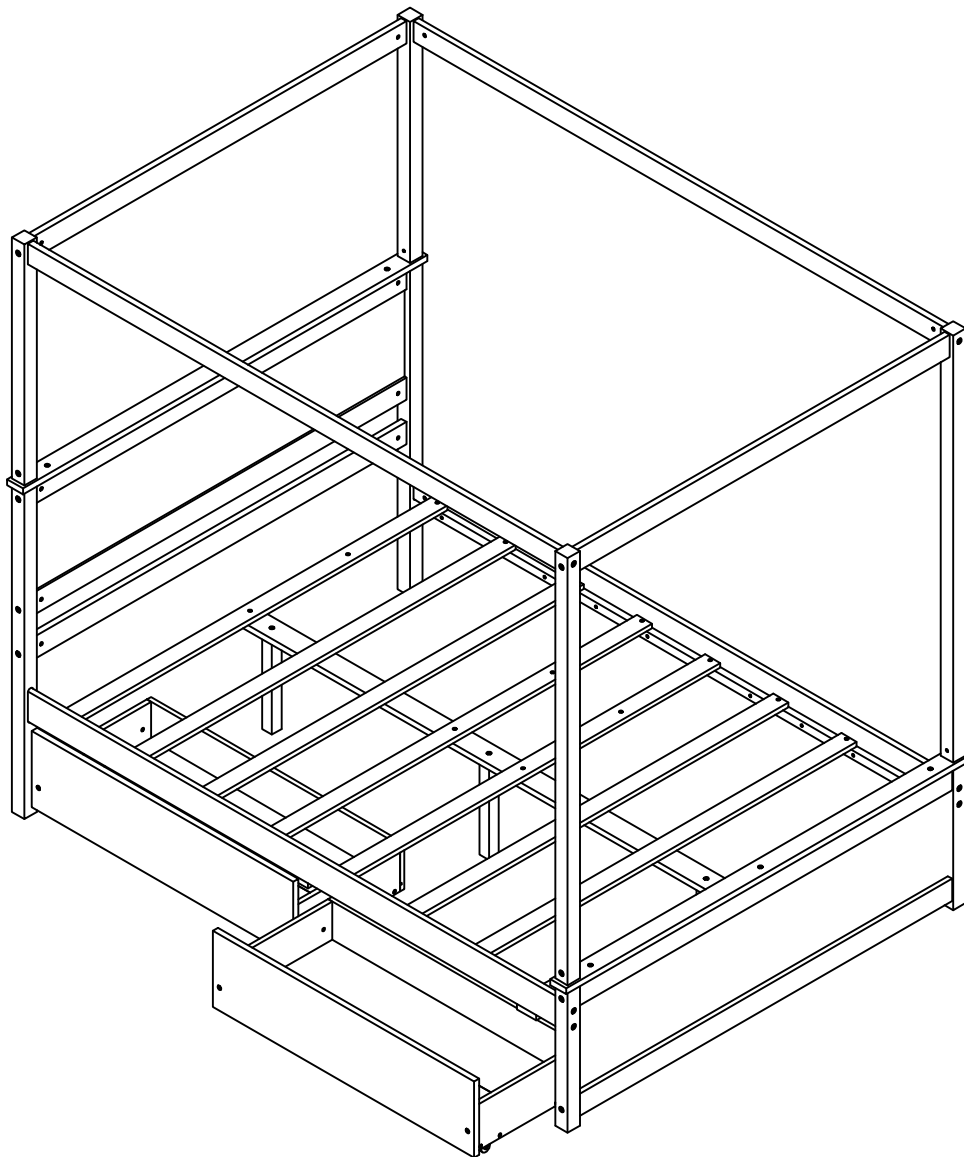

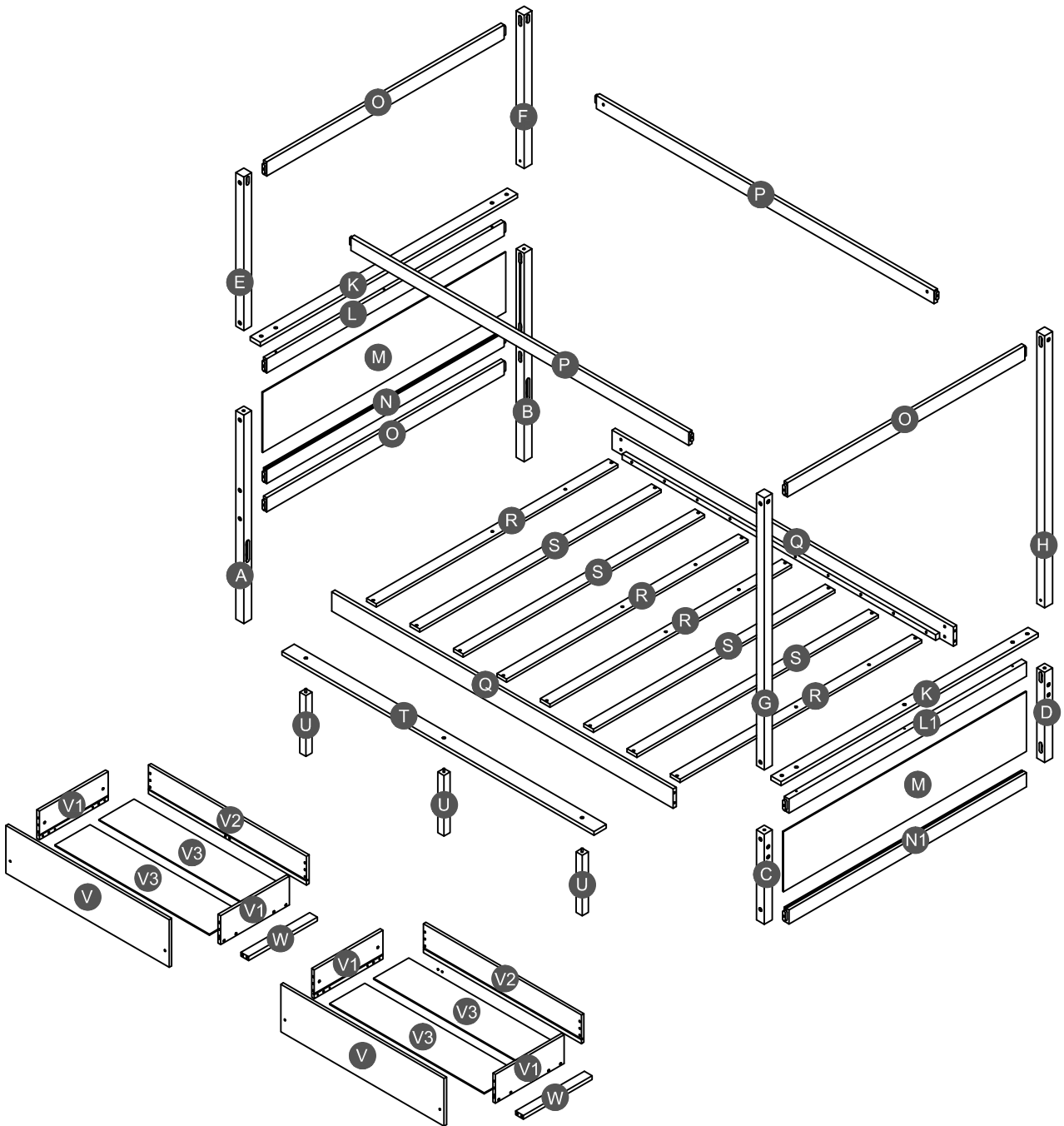



FULL BED WITH 2 DRAWERS



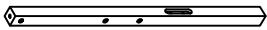

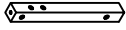
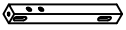
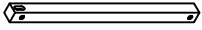
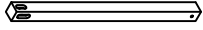
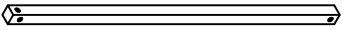
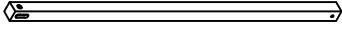

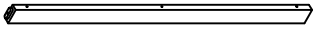
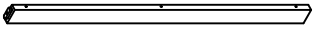
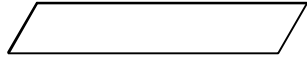
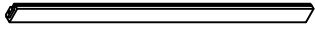
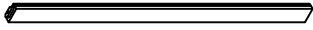
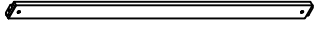
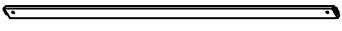
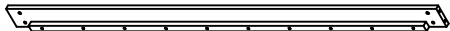

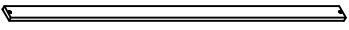
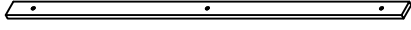
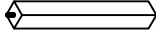
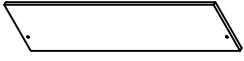
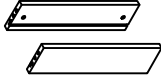
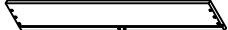
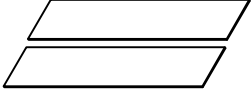
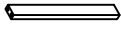

Detail View

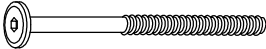
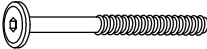
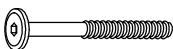

Part List

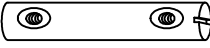
A  Lower leg left front - 1pc	B  Lower leg left back - 1pc	C  Lower leg right front - 1pc
D  Lower leg right back - 1pc	E  Upper leg left front - 1pc	F  Upper leg left back - 1pc
G  Upper leg right front - 1pc	H  Upper leg right back - 1pc	K  Cap for lower HB&FB - 2pcs
L  Horizontal bar HB - 1pc	L1  Horizontal bar FB - 1pc	M  Lower side panel HB-FB - 2pcs
N  Horizontal bar HB- 1pc	N1  Horizontal bar FB- 1pc	O  Horizontal bar - 3pcs
P  Upper horizontal bar - 2pcs	Q  Side rail - 2pcs	R  Slats - 4pcs
S  Slats - 4pcs	T  Lower support slat - 1pc	U  Leg support - 3pcs
V  Front drawer panel - 2pcs	V1  Left / right drawer panel - 4pcs	V2  Back drawer panel - 2pcs
V3  Drawer bottom - 4pcs	W  Support drawer - 2pcs	

Hardware List

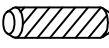
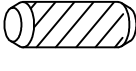
1  (Ø15)1/4"*100mm Hex-Head bolts (12pcs)	2  (Ø15)1/4"*80mm Hex-Head bolts (14pcs)	3  (Ø12)1/4"*60mm Hex-Head bolts (8pcs)
4  (Ø12)1/4"*30mm Hex-Head bolts (4pcs)	5  1/4"*15 (9.5mm) Horizontal-Hole bolts(34pcs)	6  (Ø12)1/4"*40mm Hex-Head bolts (6pcs)
7  (Ø10)1/4"*95mm Connecting bar (4pcs)	8  Ø4*30mm Wood screws (42pcs)	9  (1/4")4.5*58mm Allen key (1pc)
10  100*20*54mm Wheels (8pcs)	11  70*35*19 mm Drawer stopper (3pcs)	12  Ø8*30mm Wood dowel (24pcs)
13  Ø10*20mm Wood dowel (8pcs)		

ASSEMBLY TOOLS REQUIRED (NOT INCLUDED)

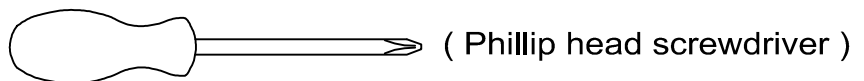

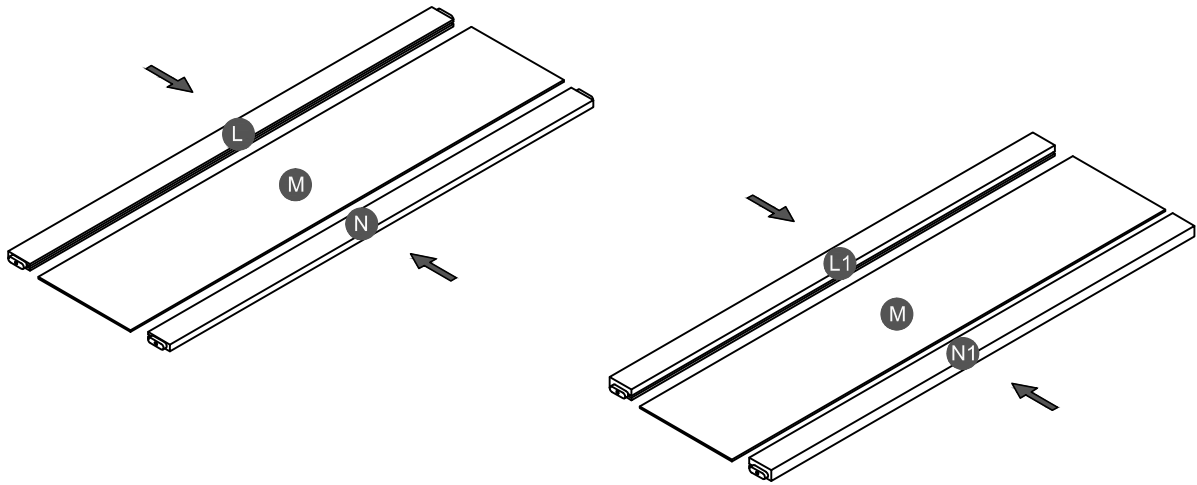

DO NOT USE POWER TOOLS TO ASSEMBLE THIS PRODUCT !

STEP 1:



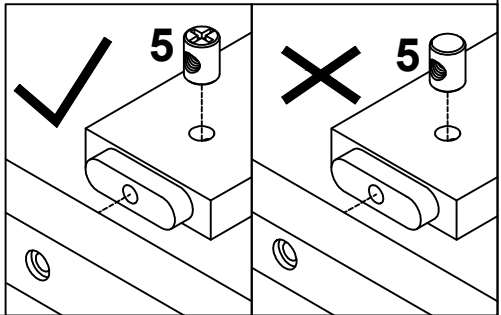
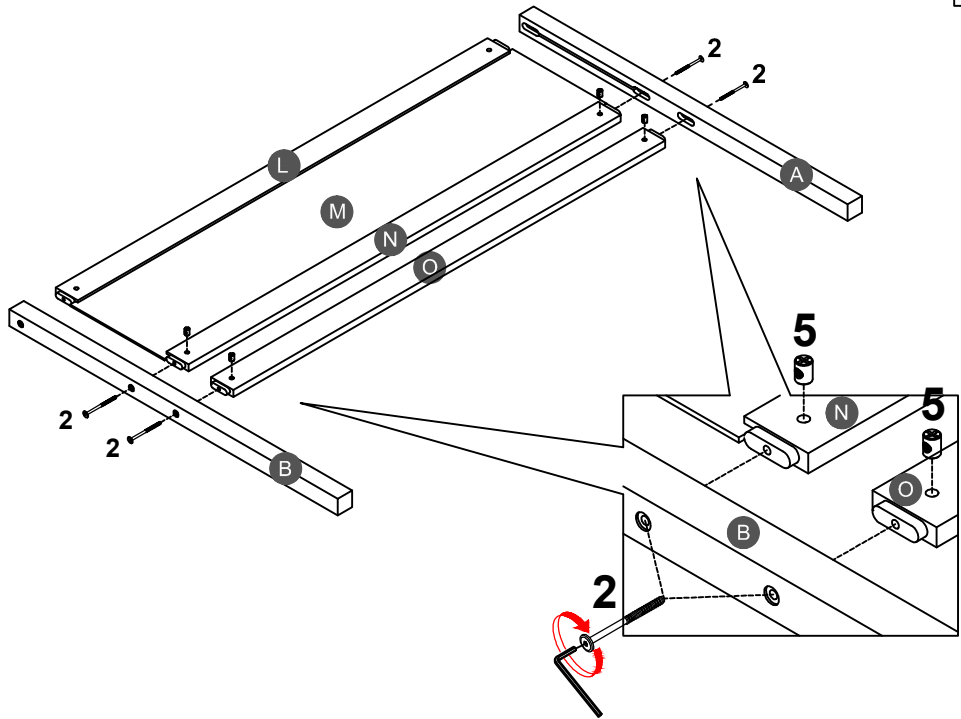

STEP 2:

2		5	
4PCS		4PCS	



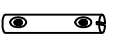

Note: Part 5 will face up with the "x" mark on it, otherwise it cannot be tightened

STEP 3:

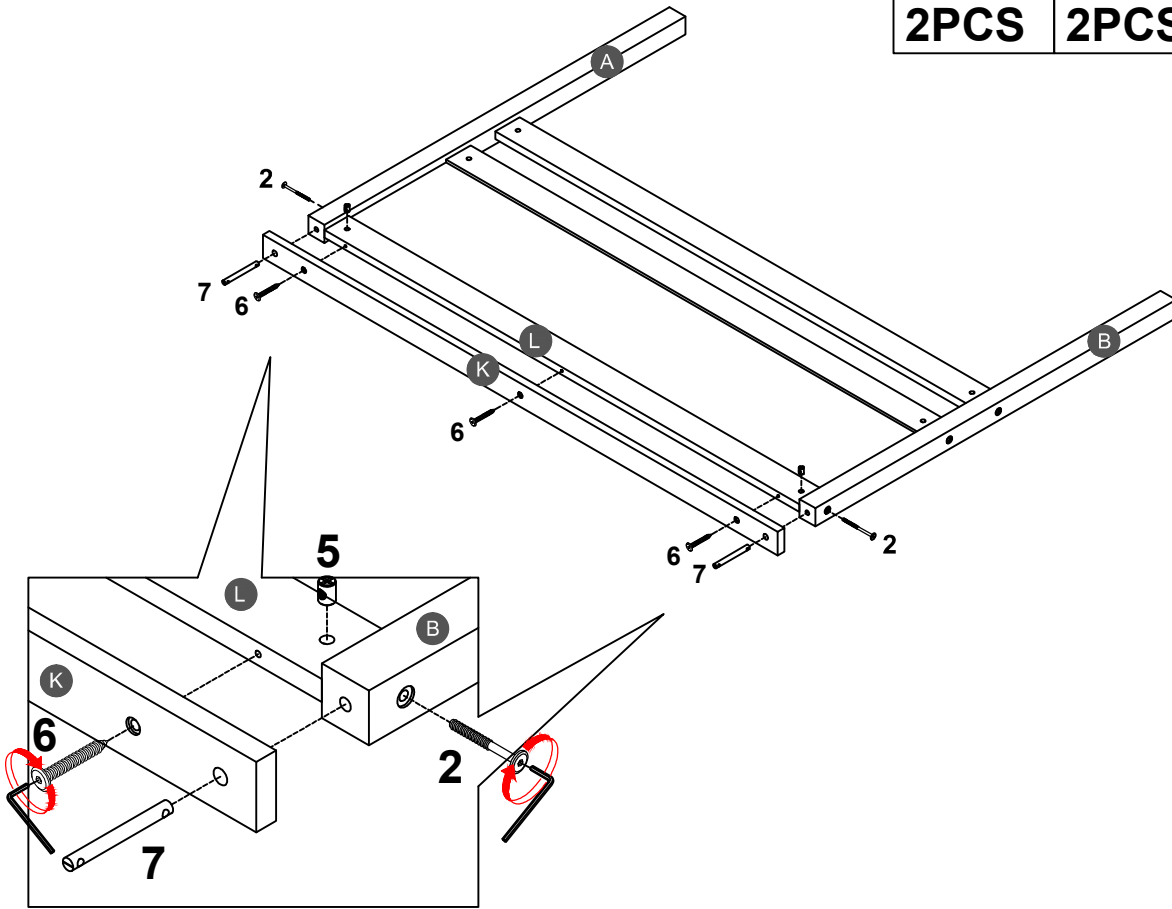
2		5		6	
2PCS		2PCS		3PCS	
				7	
				2PCS	



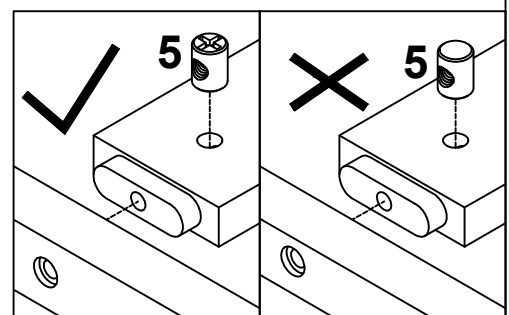
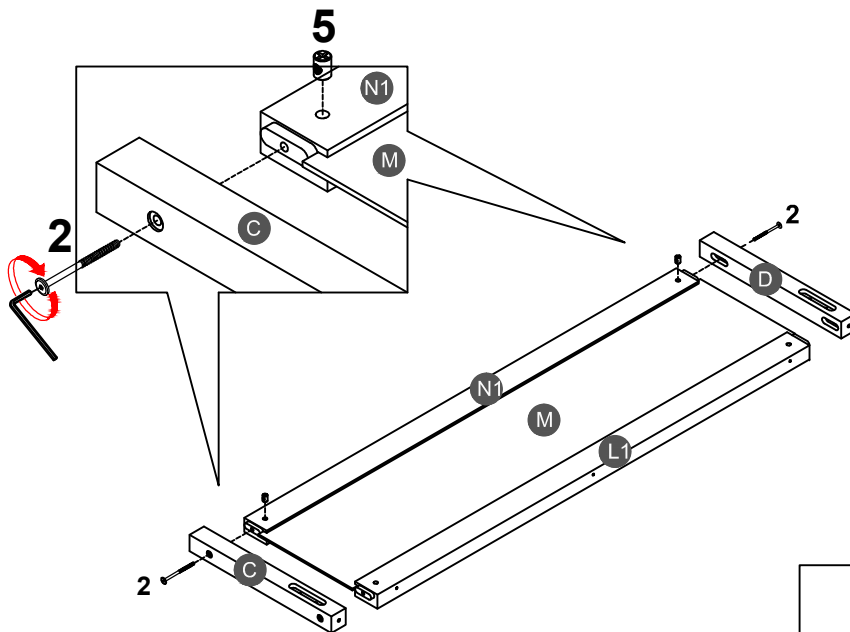

STEP 4:

2		5	
2PCS		2PCS	



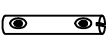

Note: Part 5 will face up with the "x" mark on it, otherwise it cannot be tightened

STEP 5:

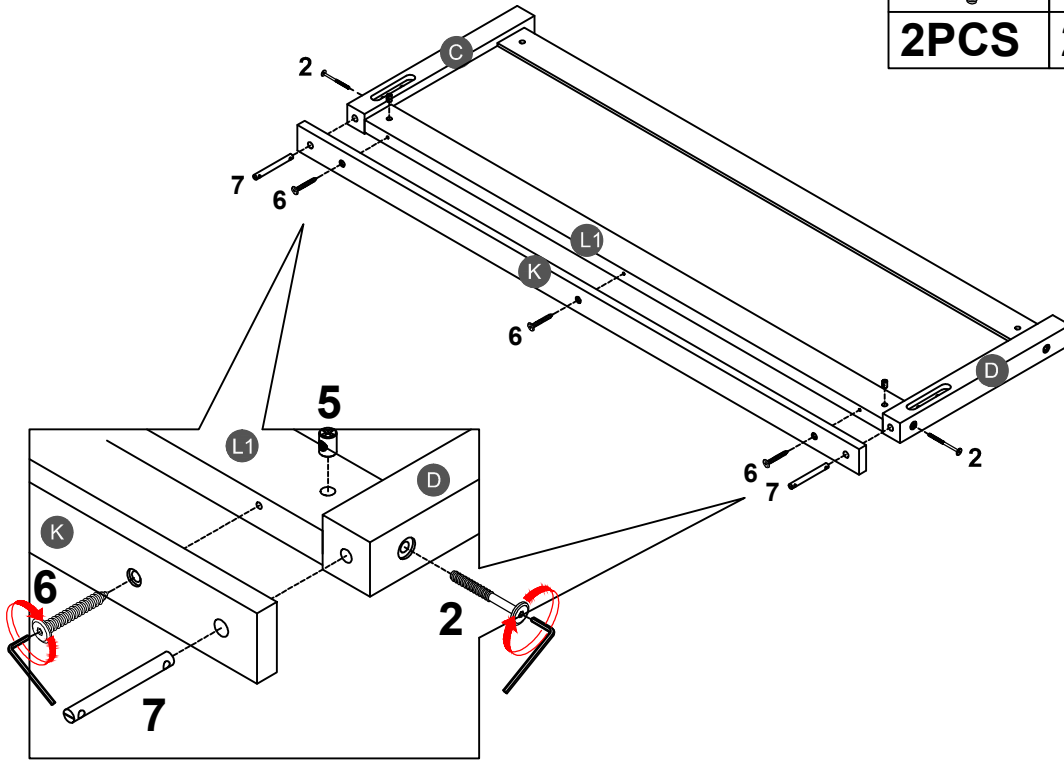
2		5		6	
2PCS		2PCS		3PCS	
			7		
			2PCS		



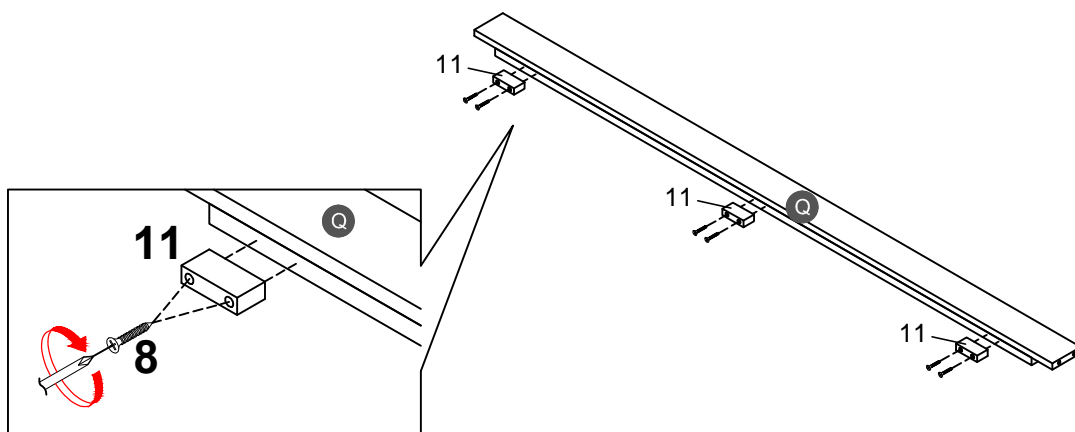

STEP 6:

8		11	
6PCS		3PCS	





Drawer stopper (11) with lower side rail front (Q) by using screw (8).

STEP 7:

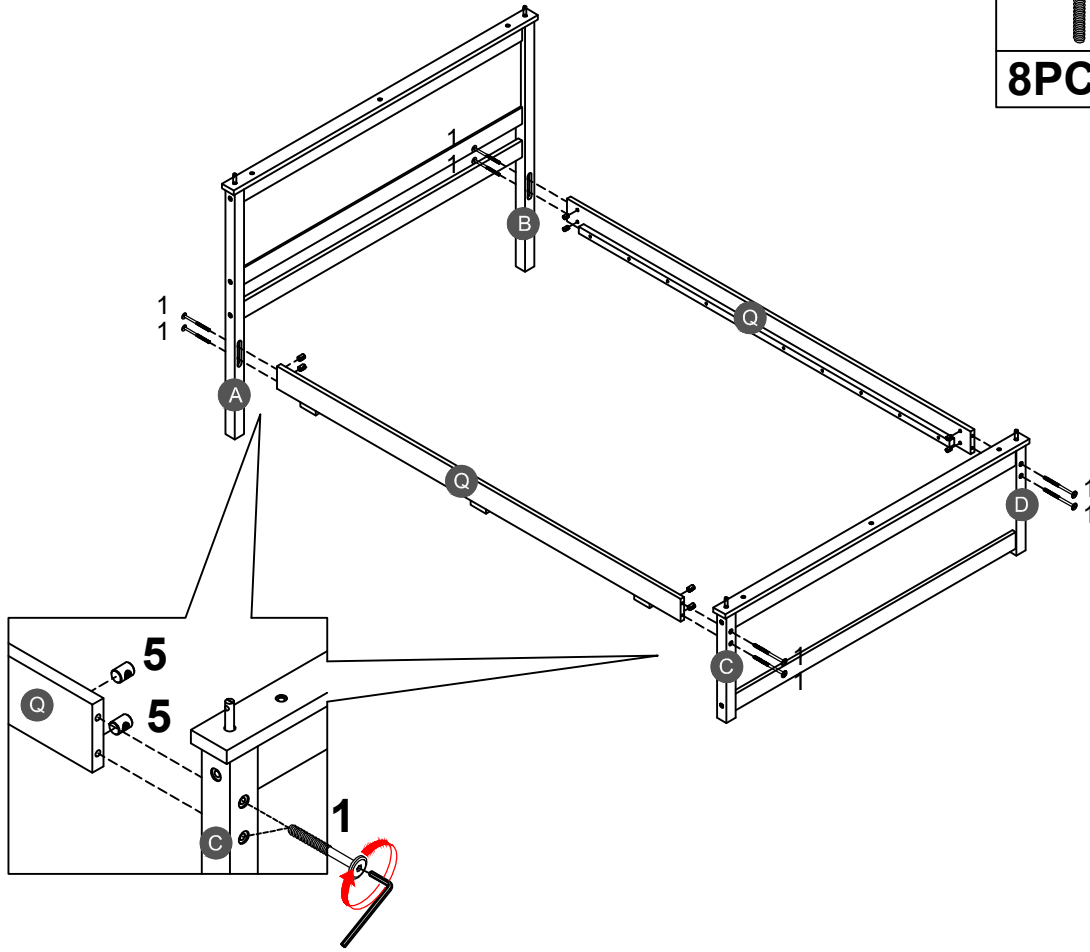
1		5	
8PCS		8PCS	



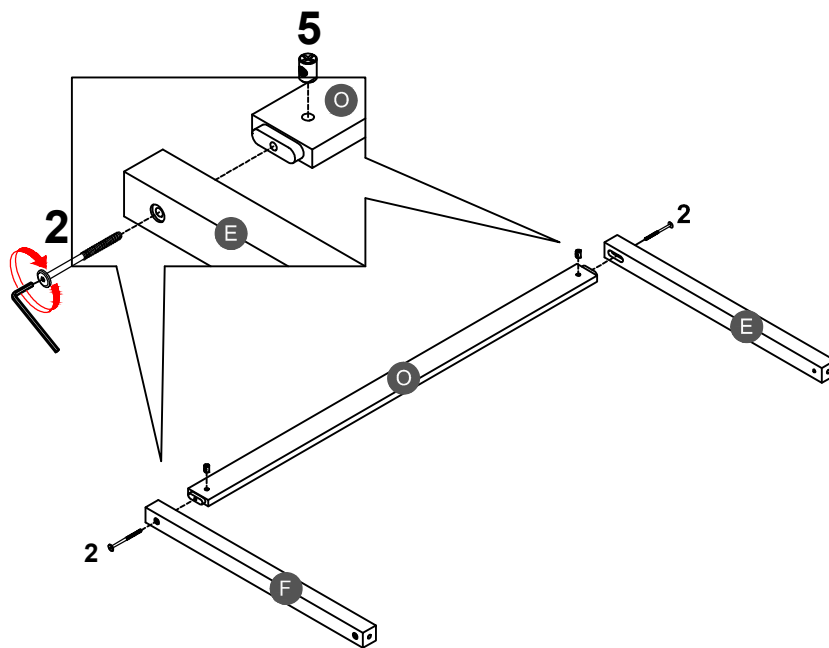

STEP 8:

2		5	
2PCS		2PCS	



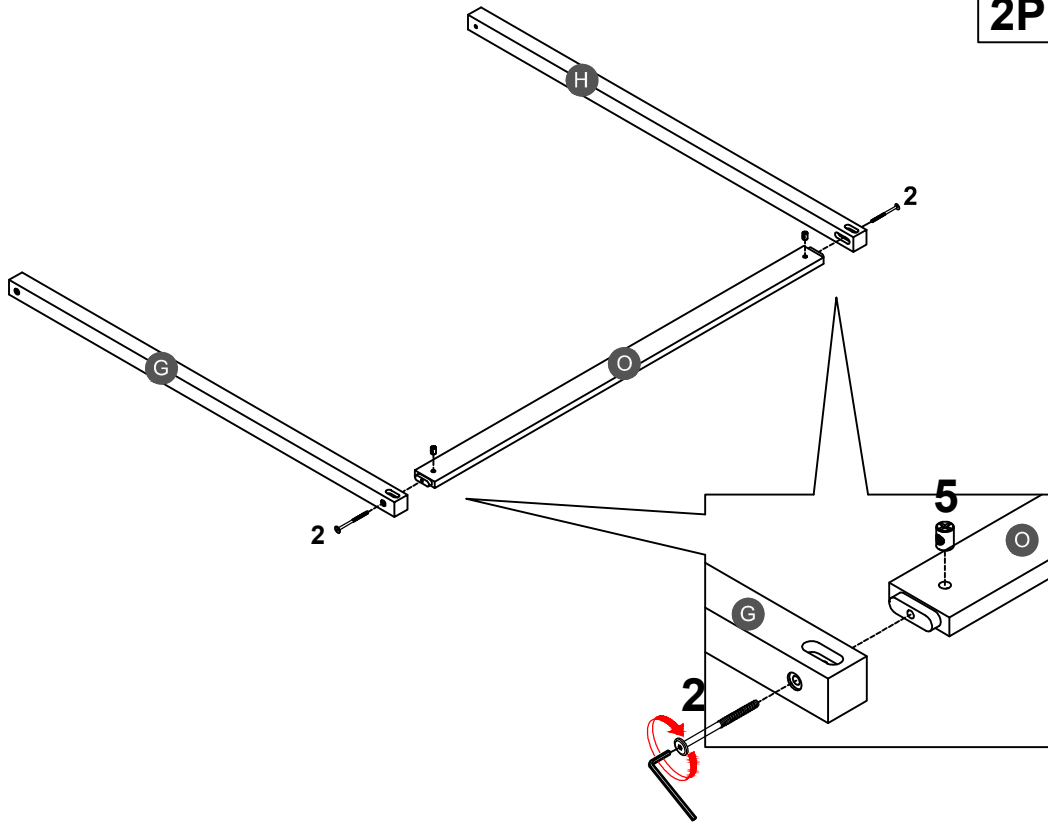

STEP 9:

2		5	
2PCS		2PCS	



STEP 10:

1		5	
4PCS		4PCS	

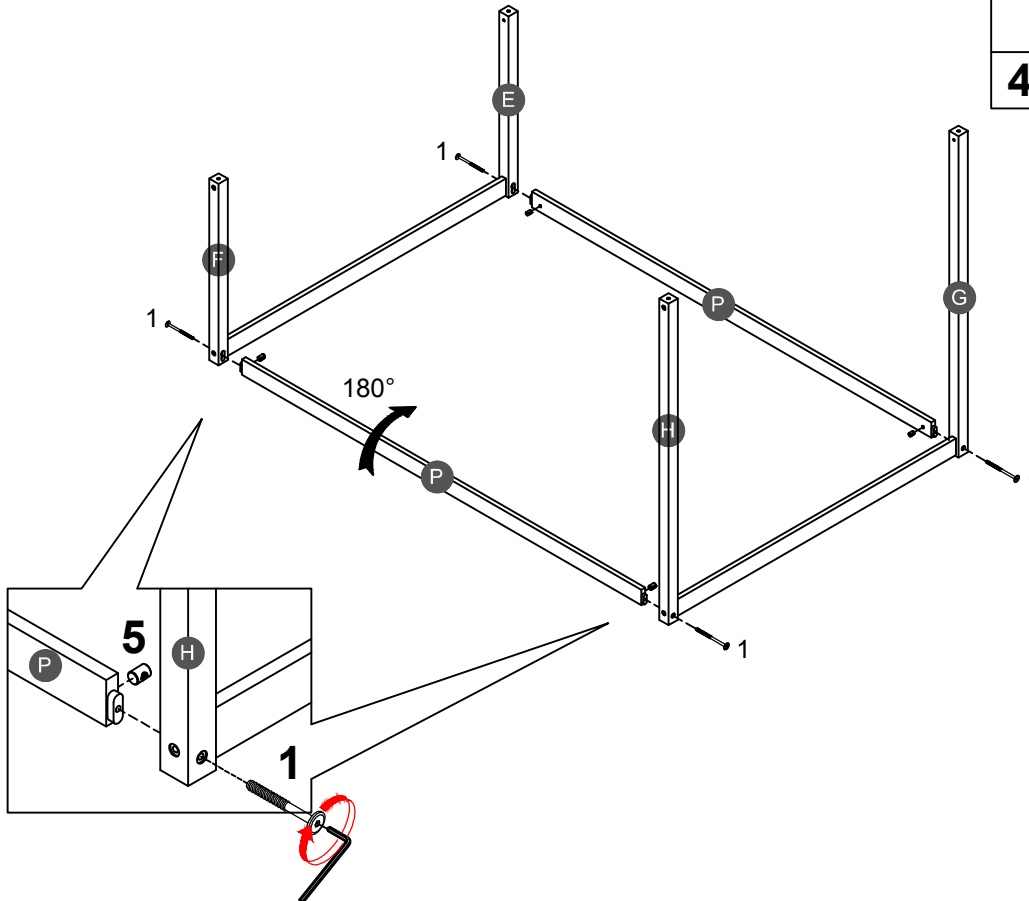

STEP 11:

4



4PCS

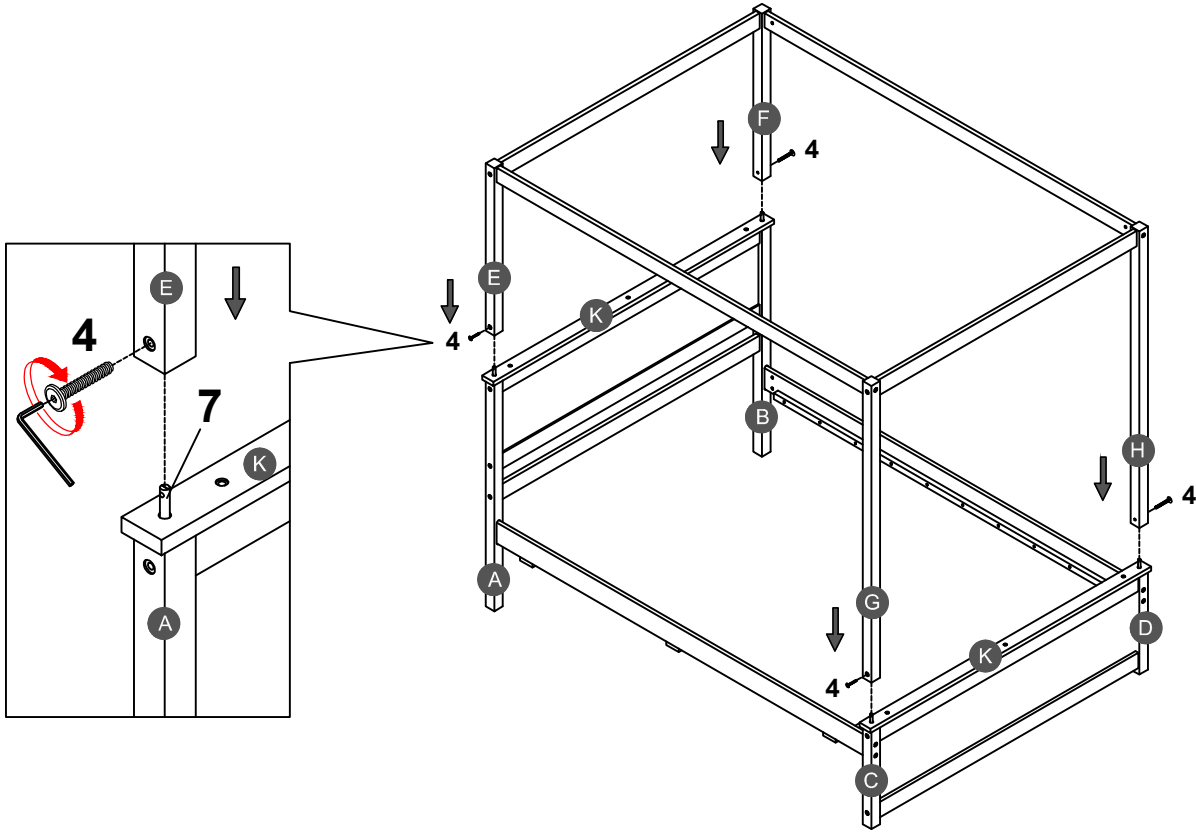

STEP 12:

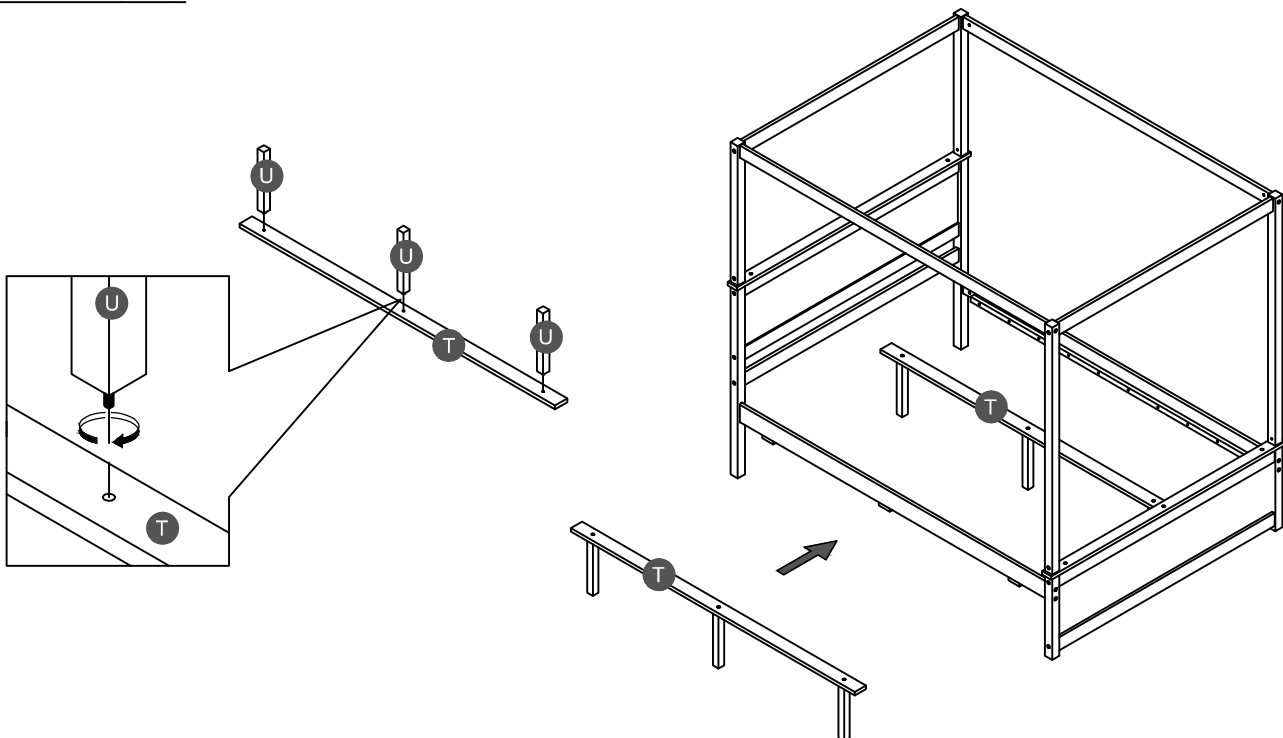

Assembling leg support (U) with lower support slat (T) later rotate, Move support slat inside Full bunkbed.

STEP 13:

8



20PCS

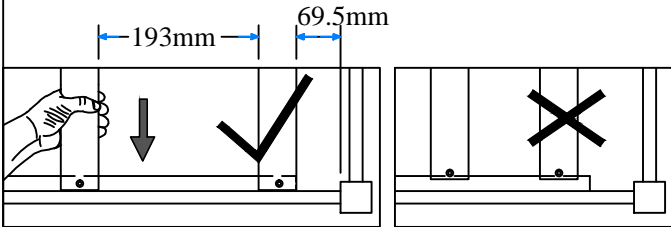
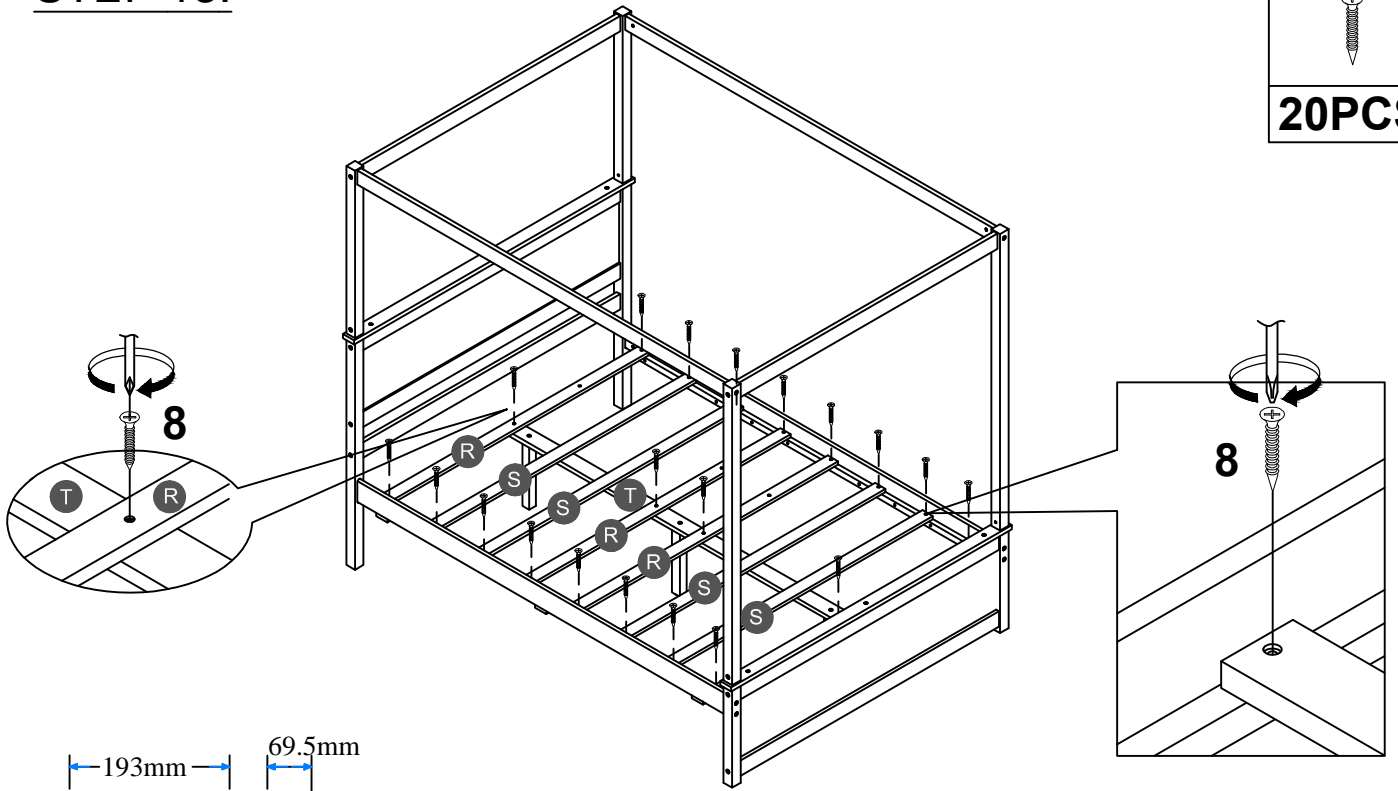

Note: Do not lock the screws of the bed slats to the outermost edge of the bed slats, you need to leave a certain space at the edges, otherwise it will cause the board to break. Do not lock the bed slats on the edge of the wood, please hold firmly before screwing, hold it in place with one hand, then lock the screw.

STEP 14:

3		5		12	
4PCS		4PCS		8PCS	

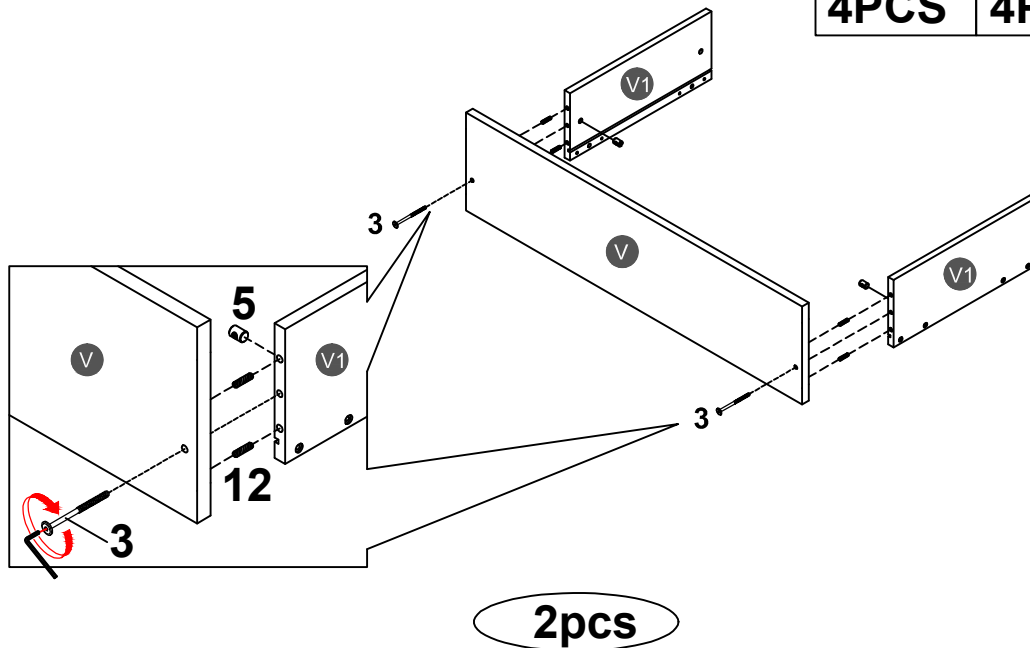

STEP 15:

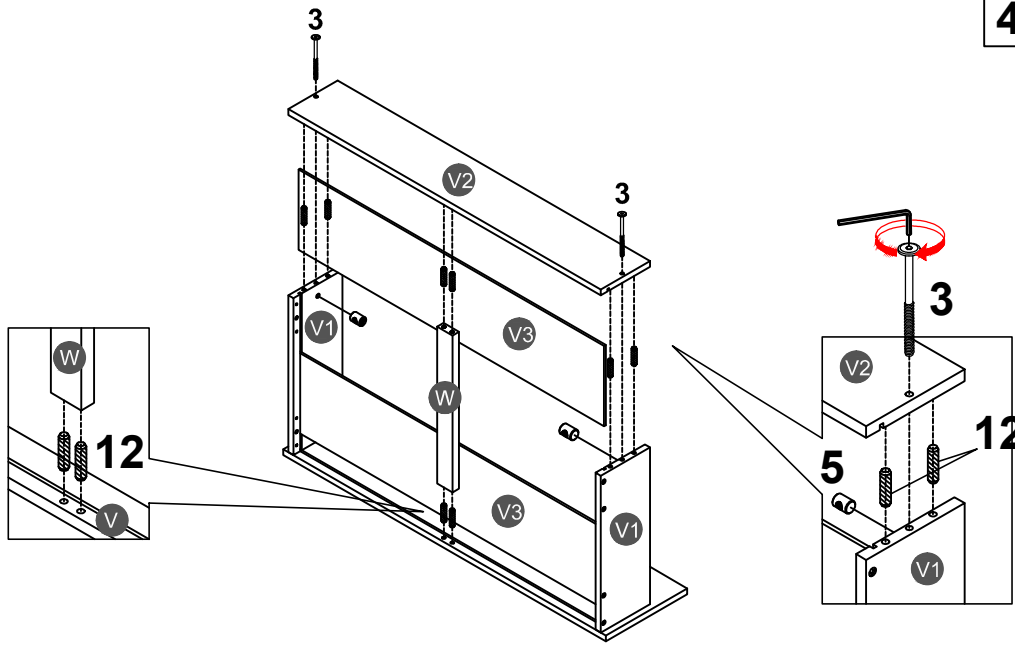

3		5	
4PCS		4PCS	
		12	
		16PCS	

2pcs

STEP 16:

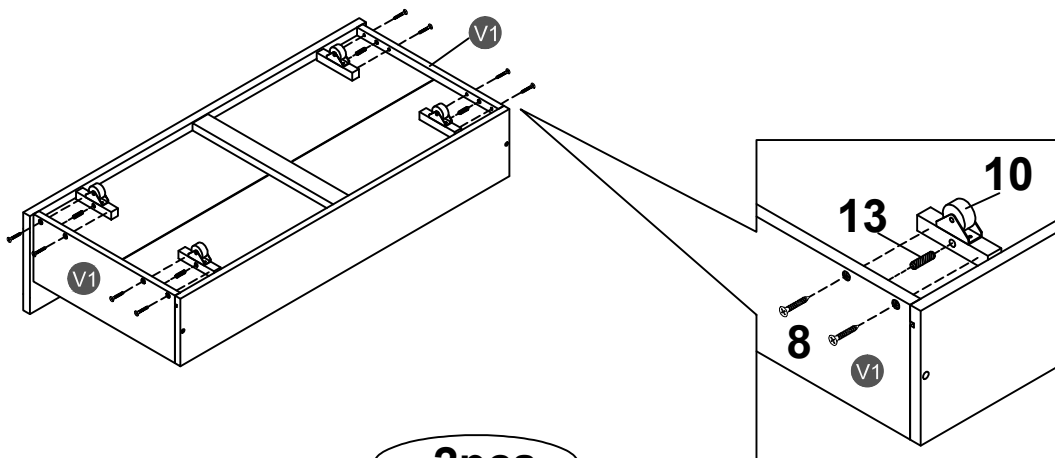

8		10		13	
16PCS		8PCS		8PCS	

2pcs

STEP 17:

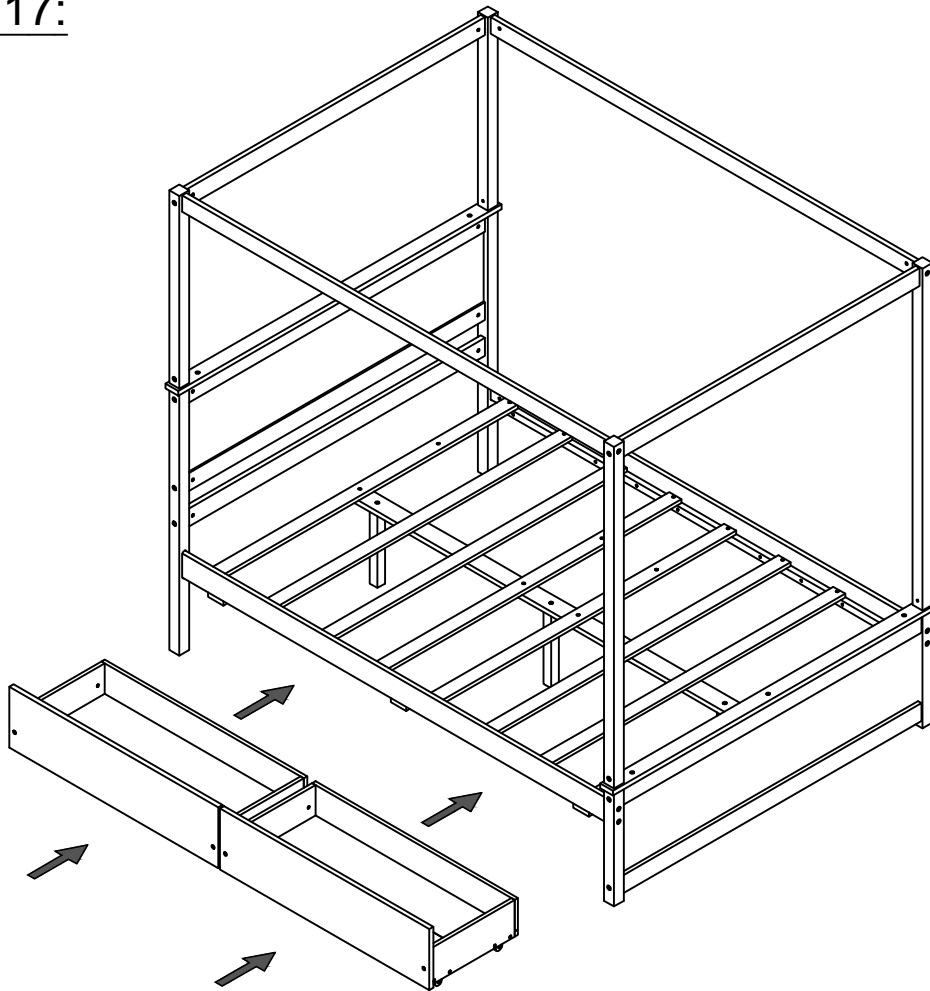

Push Drawer under the bottom of Bunkbed.

