

**ASSEMBLY INSTRUCTIONS**  
**COASTER FINE FURNITURE**

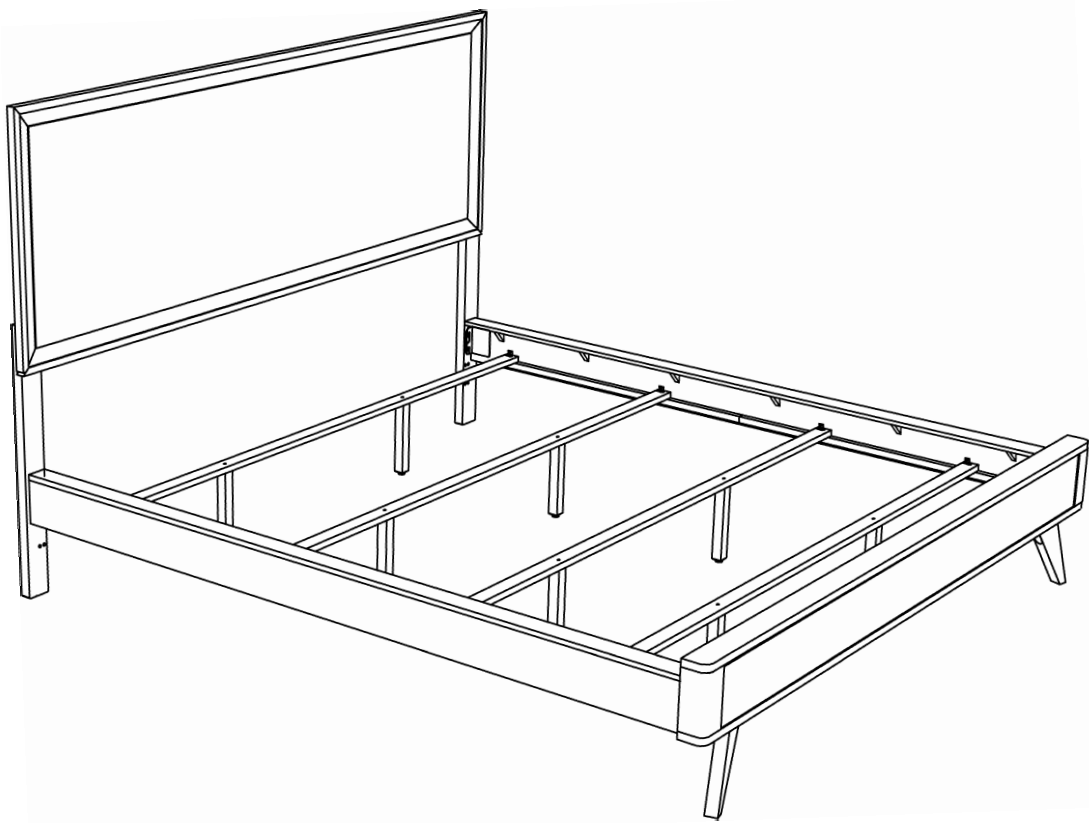

*Fine Furniture for every stage of life*

**223651KW (B1&B2)**  
**California King Bed**

# ITEM: 223651KW (B1&B2)



## ASSEMBLY INSTRUCTIONS

### ASSEMBLY TIPS:

1. Remove hardware from box and sort by size.
2. Please check to see that all hardware and parts are present prior to start of assembly.
3. Please follow attached instructions in the same sequence as numbered to assure fast & easy assembly.



### WARNING!

1. Don't attempt to repair or modify parts that are broken or defective. Please contact the store immediately.
2. This product is for home use only and not intended for commercial establishments.









ASSEMBLY TIME

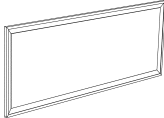

20 MINUTES

## PARTS IDENTIFICATION

### B1 (BOX 1)

A	HEADBOARD PANEL		1PC
B	FOOTBOARD PANEL		1PC
C	RIGHT HEADBOARD LEG		1PC
D	LEFT HEADBOARD LEG		1PC
E	BED SLAT		4PCS
F	BED SLAT SUPPORT WITH LEVELER		8PCS
G	FOOTBOARD LEG		2PCS

### B2 (BOX 2)

H	BED RAIL		2PCS
HB	223651KE(B1) FROM BOX 1 HEADBOARD COMPLETE		1PC
FB	223651KE(B1) FROM BOX 1 FOOTBOARD COMPLETE		1PC

### NOTE:

Phillips head screw driver is required in the assembly process; however, manufacturer does not provide this item.

# ITEM: 223651KW (B1&B2)



## ASSEMBLY INSTRUCTIONS

### ASSEMBLY TIPS:

1. Remove hardware from box and sort by size.
2. Please check to see that all hardware and parts are present prior to start of assembly.
3. Please follow attached instructions in the same sequence as numbered to assure fast & easy assembly.







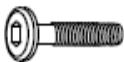

### WARNING!

1. Don't attempt to repair or modify parts that are broken or defective. Please contact the store immediately.
2. This product is for home use only and not intended for commercial establishments.

## HARDWARE IDENTIFICATION

### Z-B1 (BOX 1) - HARDWARE PACK IS LOCATED IN 223651KW (B1)

1	<b>SHORT BOLT</b> (M6 x 30mm - BLK)		6PCS
2	<b>LONG BOLT</b> (M6 x 40mm - BLK)		2PCS
3	<b>LOCK WASHER</b> (1/4" - BLK)		8PCS
4	<b>FLAT WASHER</b> (1/4" x 13mm - BLK)		8PCS
5	<b>SMALL ALLEN WRENCH</b> (M4 x 60mm - BLK)		1PC
6	<b>BIG ALLEN WRENCH</b> (M5 x 65mm - BLK)		1PC
7	<b>WOOD DOWEL</b> (8mm x 30mm)		2PCS

### Z-B2 (BOX 2) - HARDWARE PACK IS LOCATED IN 223651KW (B2)

8	<b>PAN HEAD SCREW</b> (M3.5 x 16mm - BLK)		16PCS
9	<b>L-BRACKET</b>		8PCS

### NOTE:

Phillips head screw driver is required in the assembly process; however, manufacturer does not provide this item.

# ITEM: 223651KW (B1&B2)



## ASSEMBLY INSTRUCTIONS

### STEP 1

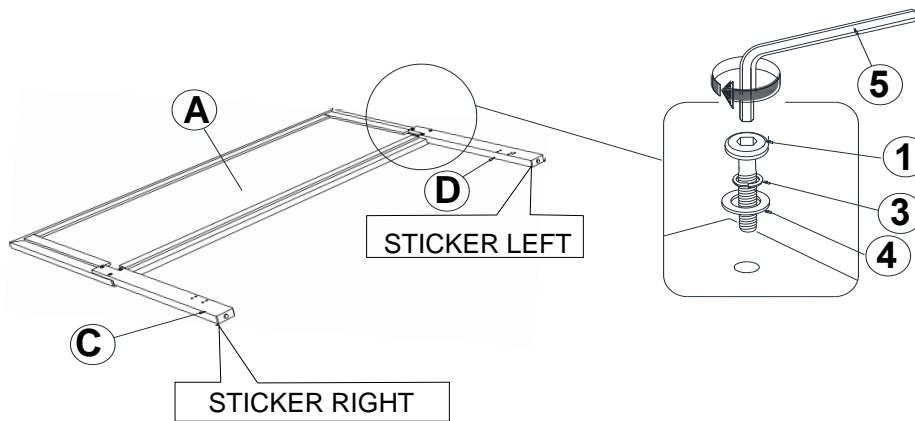

**\* BACK VIEW \***

Note: please take note of marking sticker (L & R) on the headboard legs.

### STEP 2

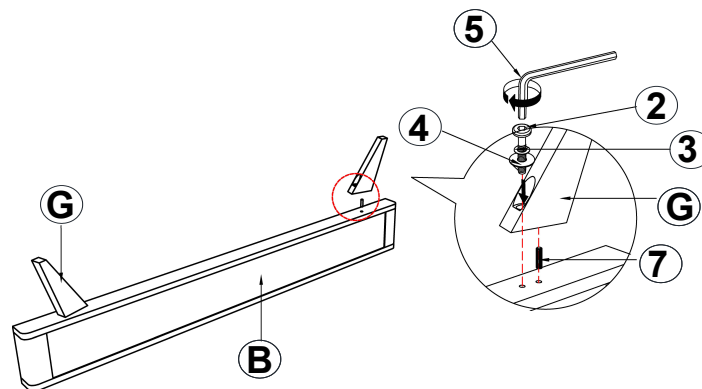

### STEP 3

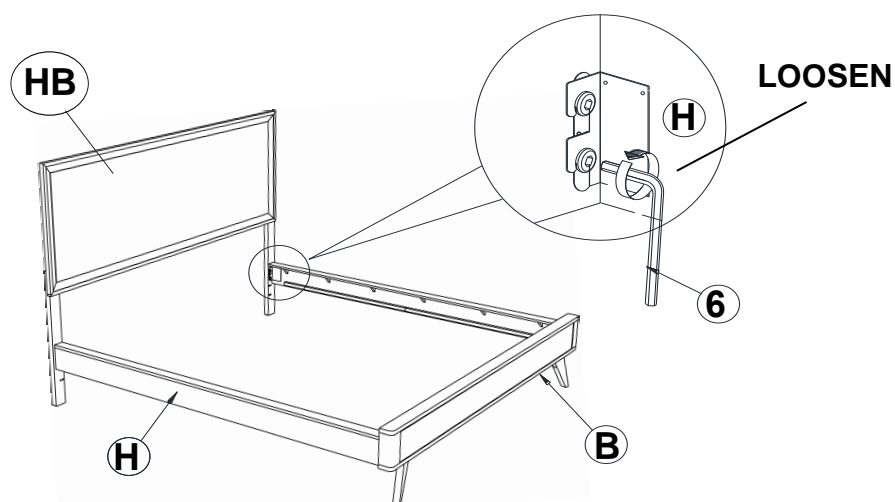

**ASSEMBLY INSTRUCTIONS**

**STEP 4**

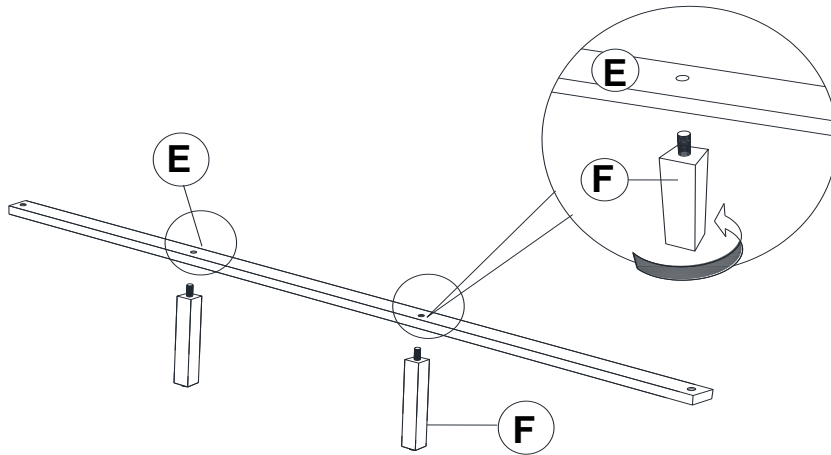

**STEP 5**

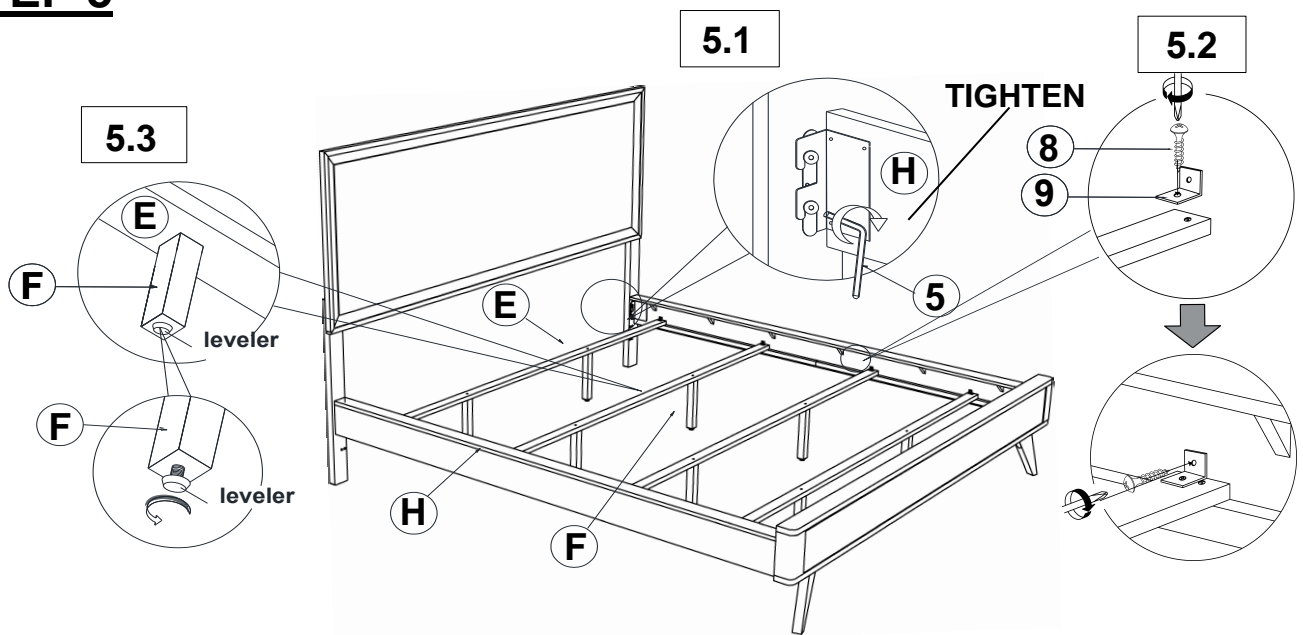

**STEP 6**  
**COMPLETE**

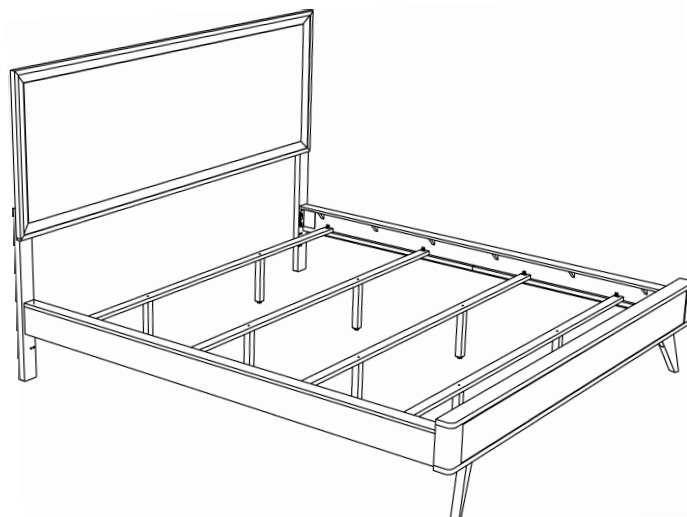

# ITEM: 223651KW (B1&B2)



Inner Size : 73.25"W x 86.00"D

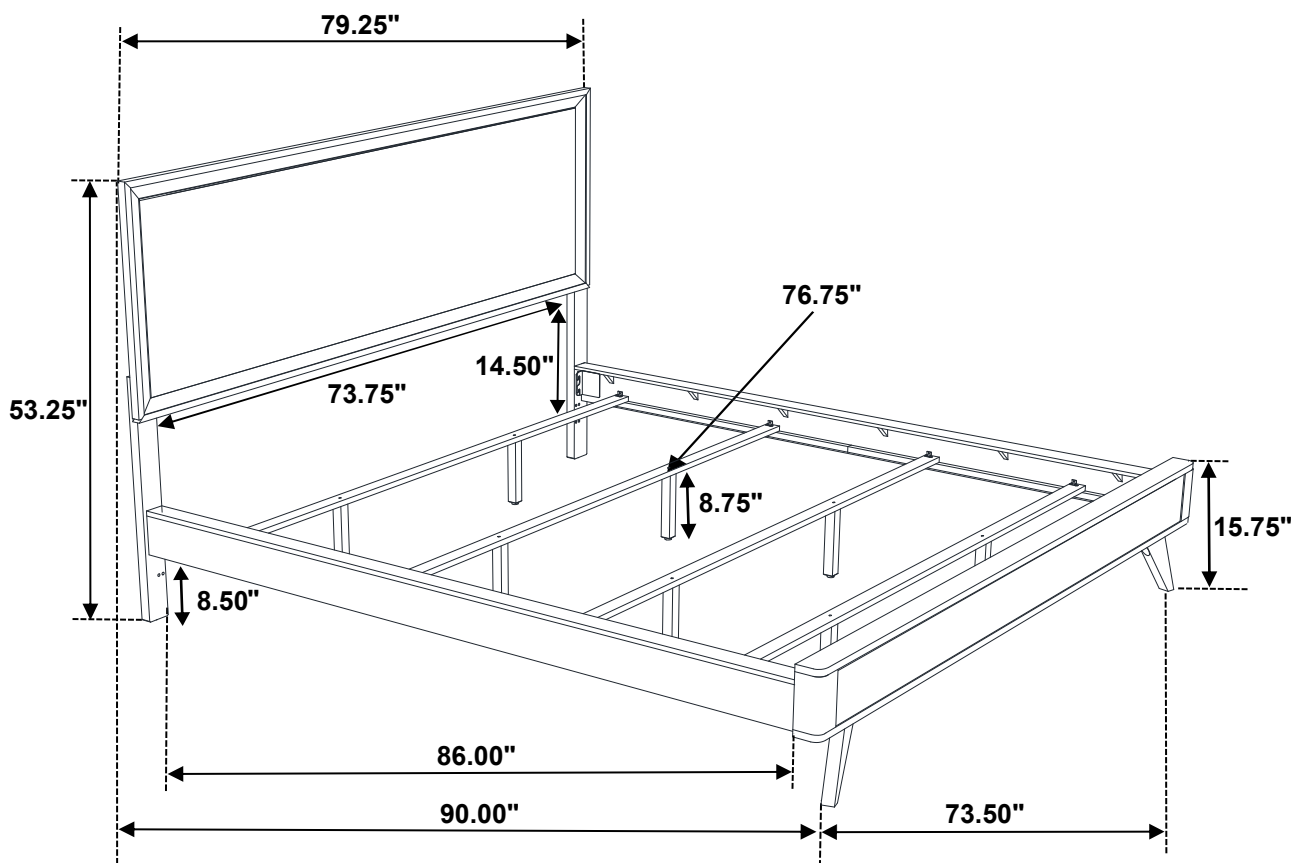

Note : Dimension tolerance  $\pm 5\%$