

Single Ultrawide Monitor Extra Tall Desk Mount

SKU: STAND-V100T

Instruction Manual

Assembly Video & Product Info
www.vivo-us.com/products/stand-v100t



[THIS PAGE HAS BEEN INTENTIONALLY LEFT BLANK]

! CAUTION! !

If you do not understand these directions, or if you have any doubts about the safety of the installation, please contact our product support team at 309-278-5303 or help@vivo-us.com for further assistance. Check carefully to make sure there are no missing or defective parts. Improper installation may cause damage or serious injury. Do not use this product for any purpose that is not explicitly specified in this manual. Do not exceed weight capacity. We cannot be liable for damage or injury caused by improper mounting, incorrect assembly or inappropriate use.



WARNING: CHOKING HAZARD

SMALL PARTS - NOT FOR CHILDREN UNDER 3 YEARS. ADULT SUPERVISION IS REQUIRED.



DO NOT EXCEED WEIGHT CAPACITY

FAILURE TO DO SO MAY RESULT IN SERIOUS INJURY.

We're Here for You

Open **Monday - Friday 7:00am - 7:00pm** CST, our dedicated support team can offer immediate assistance with rapid response times. If any parts are received damaged or defective, please contact us. We are happy to replace parts to ensure you have a fully functioning product.



Give us a Call:
309-278-5303

AVG. RESOLUTION TIME (*within office hrs*): **5M 4S**



Chat Us:
www.vivo-us.com

AVG. RESOLUTION TIME (*within office hrs*): **< 15 M**



Email Us:
help@vivo-us.com

AVG. RESPONSE TIME (*within office hrs*): **1HR 8M**

- 23% within < 15m
- 38% within < 30m
- 61% within < 1hr
- 83% within < 2hr
- 92% within < 3hr

Package Contents



A (x1)
Upper Pole



B (x1)
Lower Pole

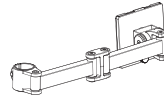

C (x1)
Arm



D (x1)
Clamp



E (x1)
Support Plate



F (x1)
Pole Cable
Clip



G (x1)
Clamp Cable
Clip



H (x2)
Arm Cable
Clip

Included Hardware & Tools



M-A (x4)
M4x12mm
Screw



M-B (x4)
M5x12mm
Screw



M-C (x4)
M5 Washer

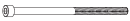

S-A (x1)
Grommet Bolt



T-A (x1)
3mm Allen
Wrench



T-B (x1)
6mm Allen
Wrench

Tools Needed:



**Phillips
Screwdriver**

Weight Capacity:



**44lbs
(20kg)**

ASSEMBLY STEPS

STEP 1

Assembly Option #1: Desk Clamp

Using the 6mm Allen Wrench (**T-B**), loosen the **Screw** located inside the Clamp (**D**), lowering the **Clamp Bracket**, creating a space larger than the thickness of your desktop.

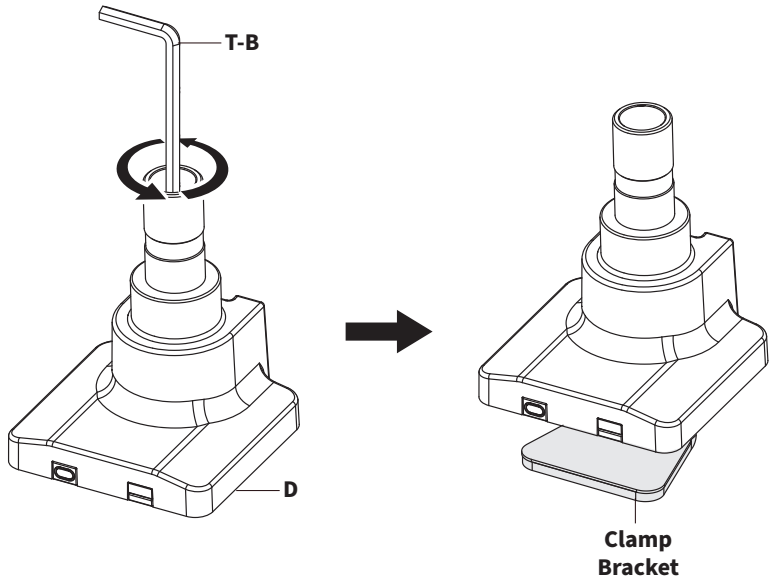

Slide the Clamp (**D**) onto your desktop in your desired position. Secure the Clamp in place using the 6mm Allen Wrench (**T-B**).

Proceed to Step 2

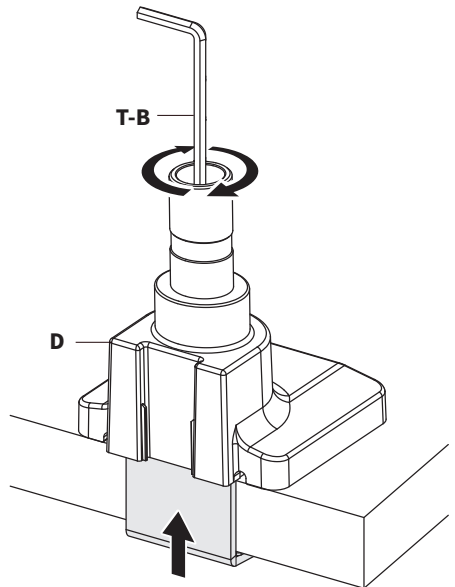

Assembly Option #2: Grommet Installation

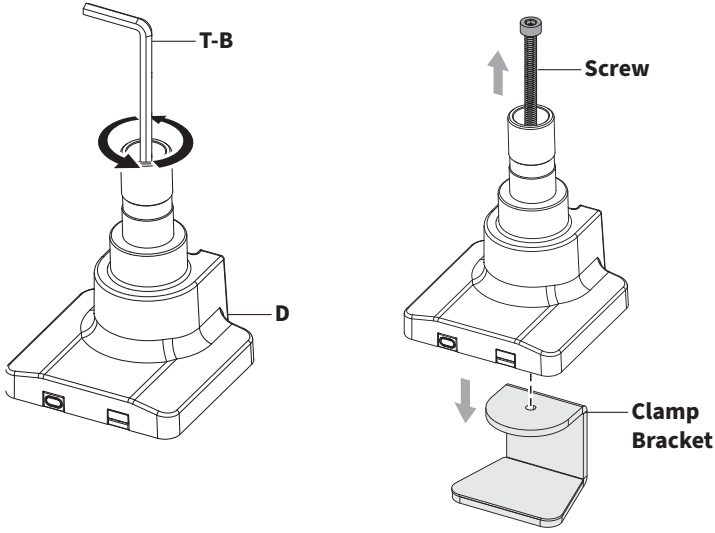

Use 6mm Allen Wrench (**T-B**) to remove the **Screw** and **Clamp Bracket** located inside the Clamp (**D**).

Both pieces can be discarded and will not be used in the remainder of the assembly.

Install Clamp (**D**) to your desktop using the Grommet Bolt (**S-A**), Support Plate (**E**), and 6mm Allen Wrench (**T-B**).

Proceed to Step 2

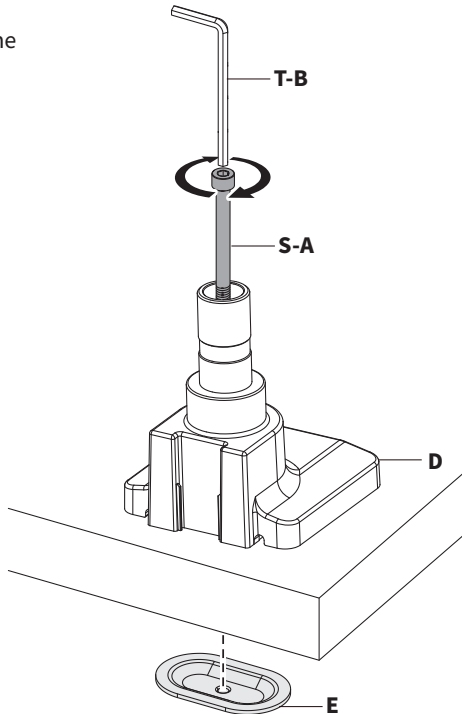

No Grommet Hole?

If you do not have an existing hole for installation, drill a hole through your desktop in your desired mounting location using a 13/32" (10mm) drill bit.

STEP 2

Slide the Lower Pole (**B**) over the **Post** on Clamp (**D**). Tighten the **Set Screw** on the Lower Pole using the 3mm Allen Wrench (**T-A**) to secure.

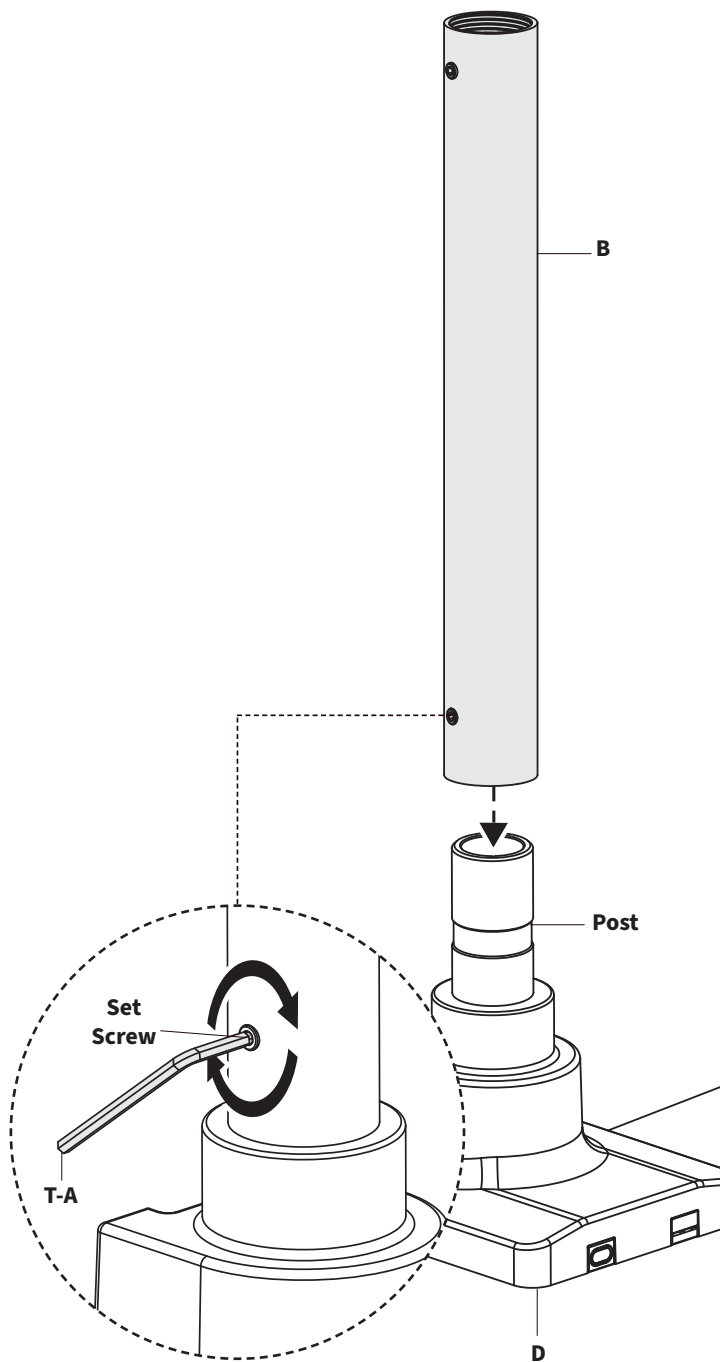

Cont'd

Slide one Pole Cable Clip (**F**) over Lower Pole, and then thread the Upper Pole (**A**) onto the Lower Pole.

Tighten the set screw on Lower Pole using the 3mm Allen Wrench (**T-A**).

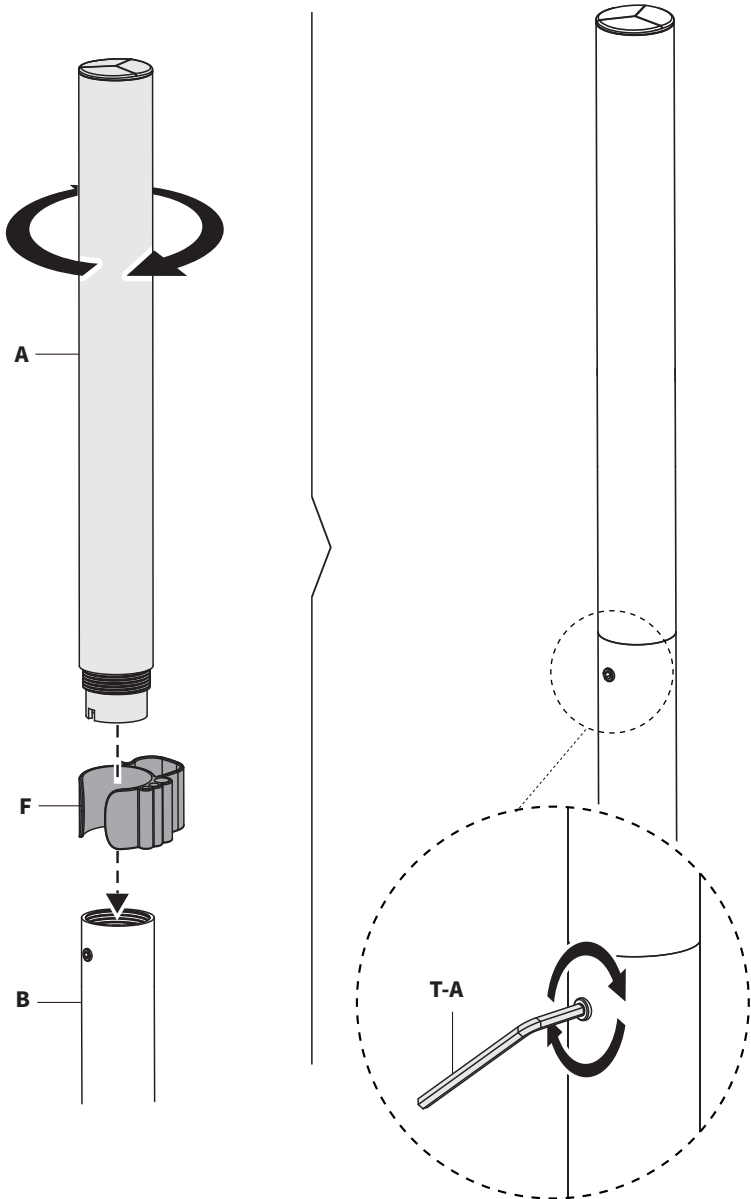

STEP 3

Unfold the Arm (C) straight, as shown below.

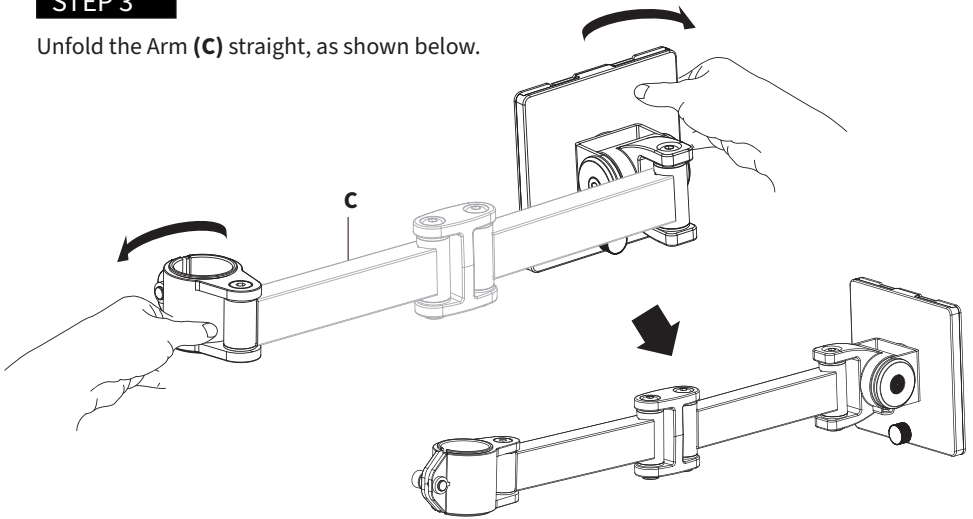

Slide the Arm Cable Clip (H) and Arm (C) onto the Pole (A). Hold Arm at the desired height and secure using the 6mm Allen Wrench (T-B). Snap Arm Cable Clips (H) onto both segments of the Arm.

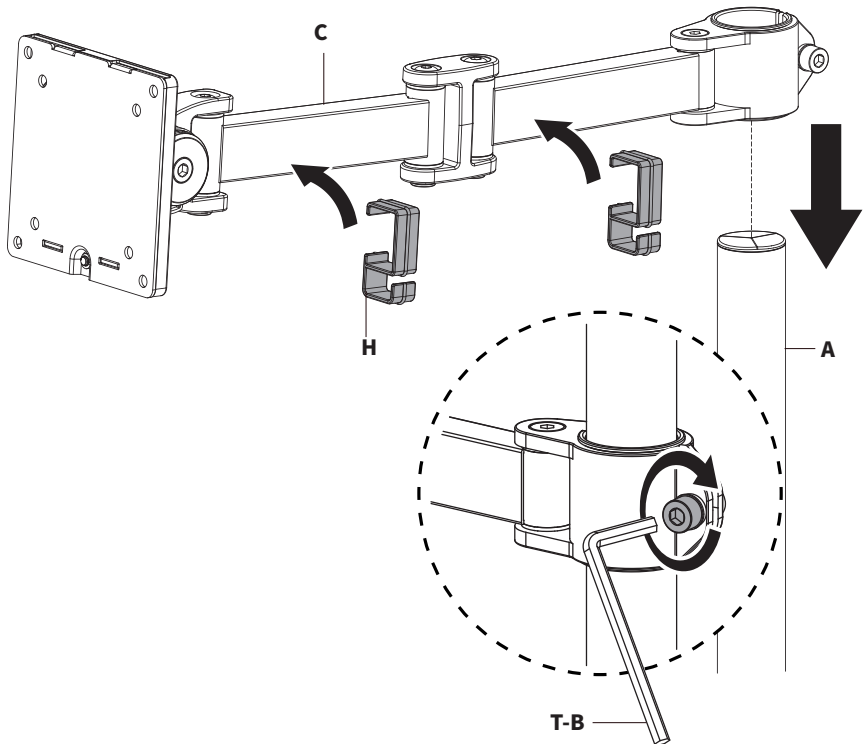

STEP 4

Loosen the Thumbscrew (**C2**) on the back of VESA Bracket (**C1**), then separate and remove VESA Plate (**C3**) by pulling out and sliding upwards.

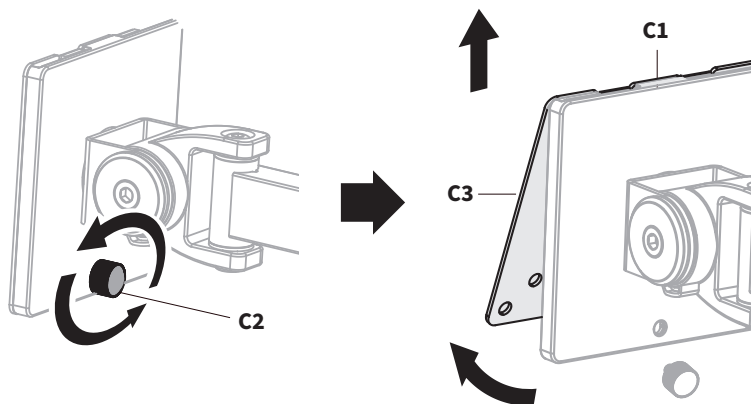

Install the VESA Plate (**C3**) onto the back of your monitor using M4x12mm Screws (**M-A**) or M5x12mm Screws (**M-B**) and M5 Washers (**M-C**), orienting the arrow on the VESA Plate pointing up. Tighten screws using a Phillips screwdriver making sure not to over tighten.

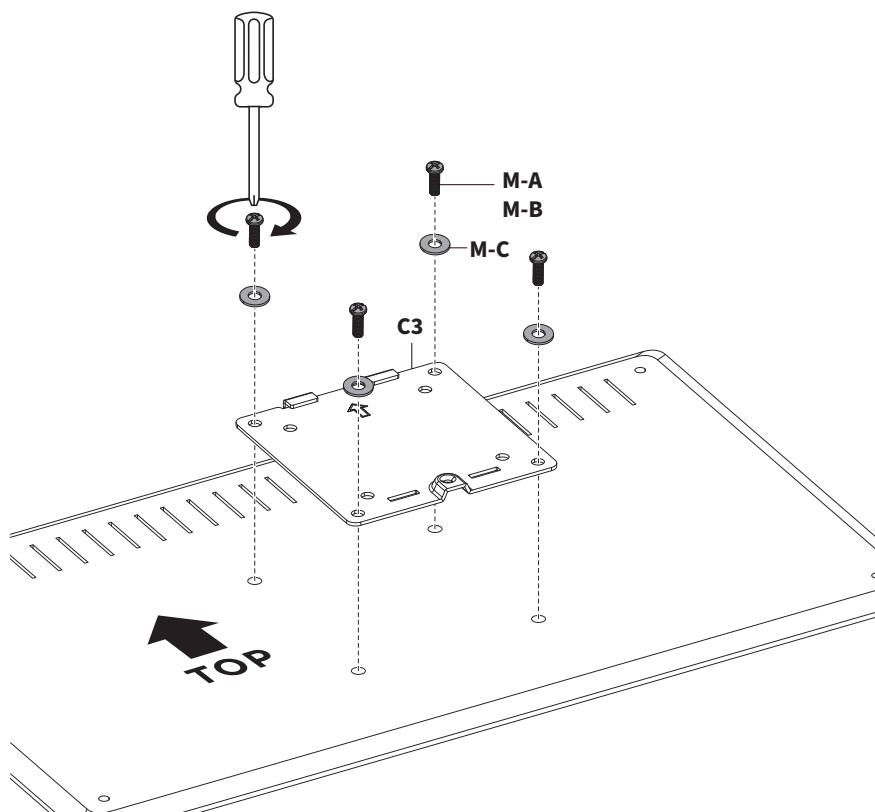

Adjusting the Tilt Joint

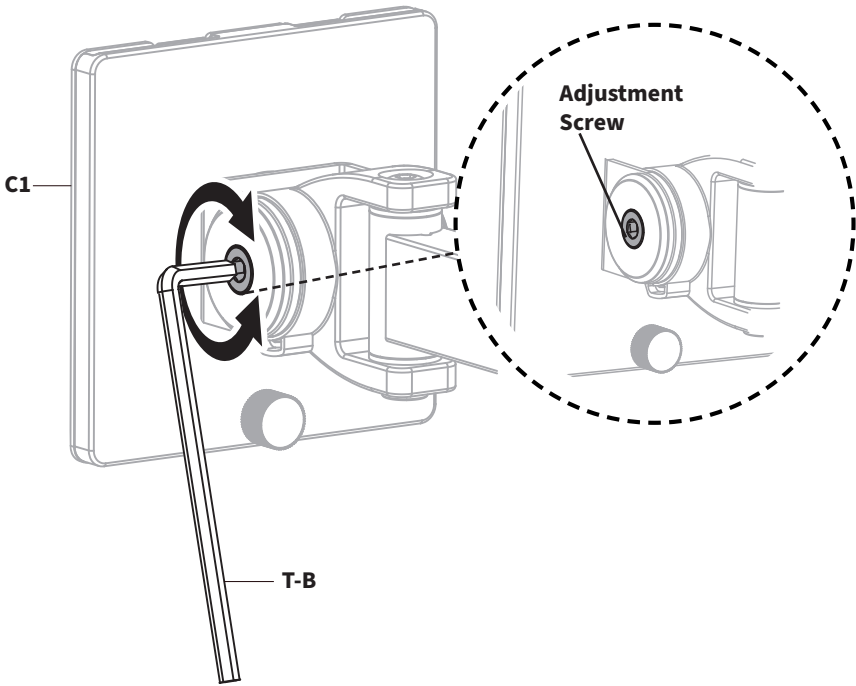

1 Loosen Tilt Joint:

Use 6mm Allen Wrench (**T-B**) to loosen the **Tilt Joint Adjustment Screw**, located on the side of VESA Bracket (**C1**).

2 Set Angle

Firmly grip the VESA Bracket and adjust to your desired viewing angle, and hold in place.

3 Lock Angle

Tighten as much as possible using the 6mm Allen Wrench (**T-B**) to lock the angle.

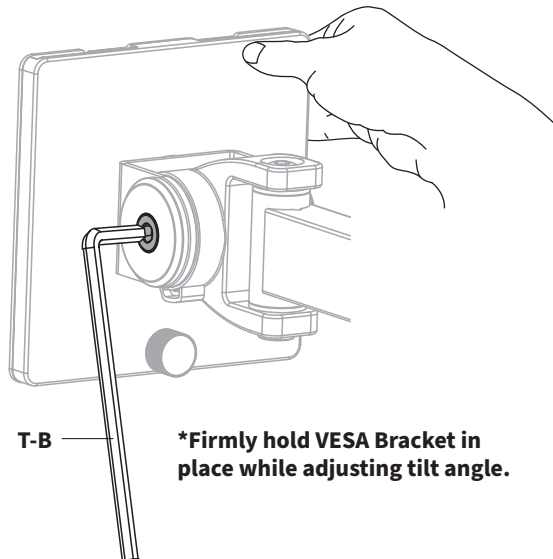

***Firmly hold VESA Bracket in place while adjusting tilt angle.**

STEP 6

With the assistance of a second person, line up the VESA Plate (**C3**) on your monitor with the VESA Bracket and the Plate Hooks into the pockets of the VESA Bracket (**C1**). Monitor & VESA Bracket may need to be angled backwards slightly when sliding on.



2 Person Mounting is Recommended

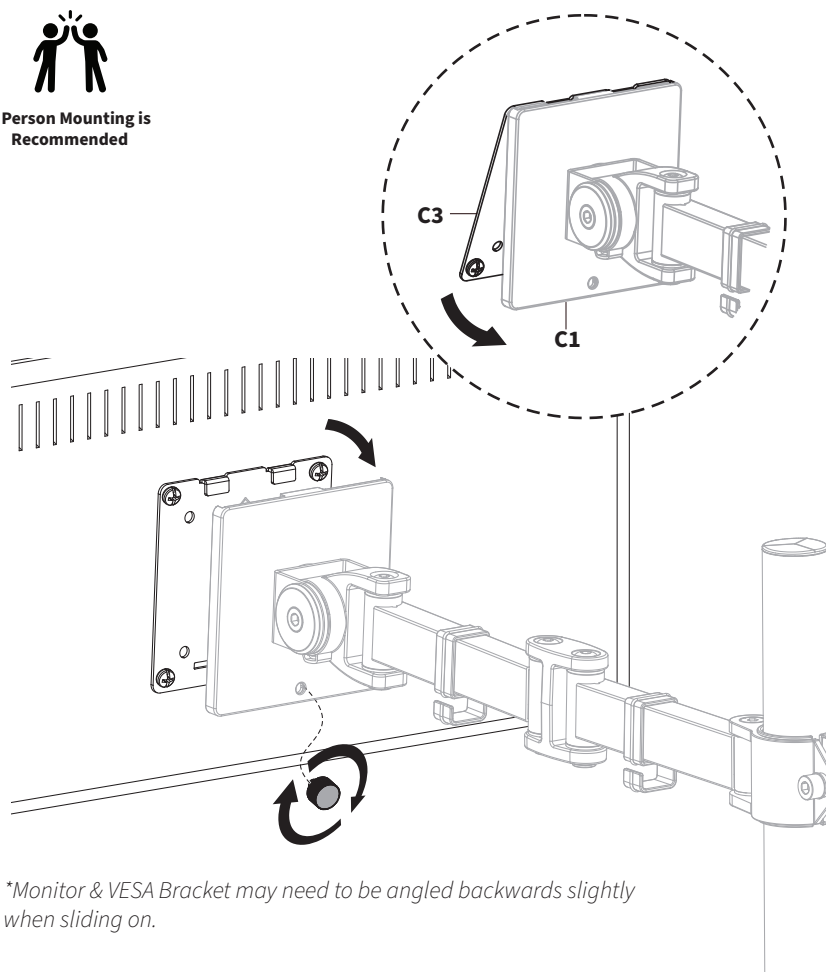

**Monitor & VESA Bracket may need to be angled backwards slightly when sliding on.*



Monitor Tilted Too Far?

**** See Next Step ****

Refer to instructions in next step to adjust. **DO NOT** try to adjust angle freely. Doing so may result in accidental damage to your screen.

Fine Tune Tilt Angle

If the monitor is angled further than intended...



Heavy Weighted/ Ultrawide Monitors

[22lbs - 44lbs]

1 Firmly Hold Monitor

Firmly grasp and hold the monitor in place. Do NOT release monitor until you have completed steps below.

2 Loosen Tilt Joint:

With a hand still on the monitor, use 6mm Allen Wrench (**T-B**) to loosen the tilt joint **Adjustment Screw**, located on the side of VESA Bracket (**C1**).

3 Set & Lock Angle

Adjust screen slightly past your desired viewing angle, then tighten the screw as much as possible using 6mm Allen Wrench (**T-B**).

4 Straighten Angle

Slowly adjust the monitor down until your desired angle is reached. Release monitor and check angle. Repeat process as necessary

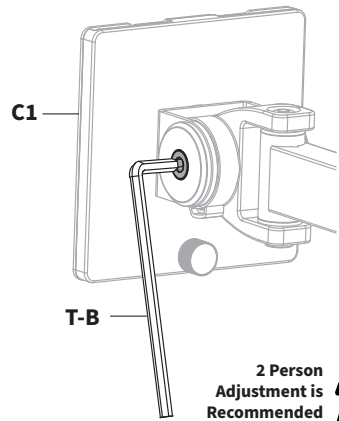
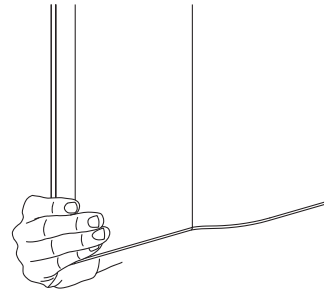

2 Person
Adjustment is
Recommended

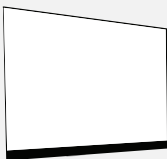

Ultra Thin Monitors



ALWAYS REMOVE MONITOR BEFORE RE-ADJUSTING

To prevent accidental damage to your screen, remove monitor and then follow Tilt Adjustment instructions. Reinstall monitor when desired angle is reached.

STEP 7

Make adjustments as desired on swivel and orientation.

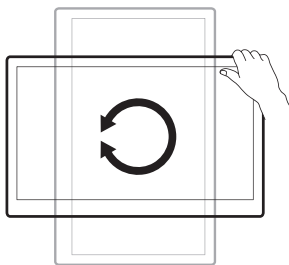
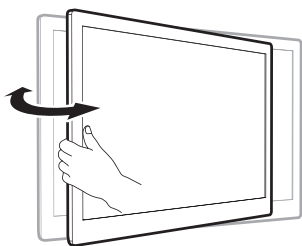

***If you are using the stand with the clamp,** do NOT extend the arm past the back of the clamp to prevent possible damage to your monitor and stand.

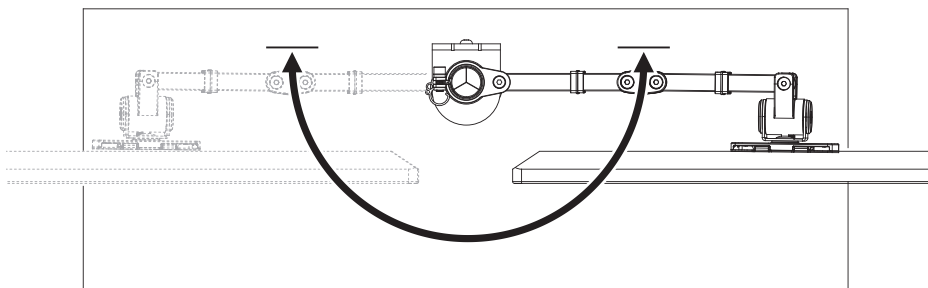

STEP 8

Route cables through the Arm Cable Clips (**H**) and Pole Cable Clip (**F**). Install the Clamp Cable Clip (**G**) onto Clamp (**D**) by placing it inside the top of the channel and sliding down.

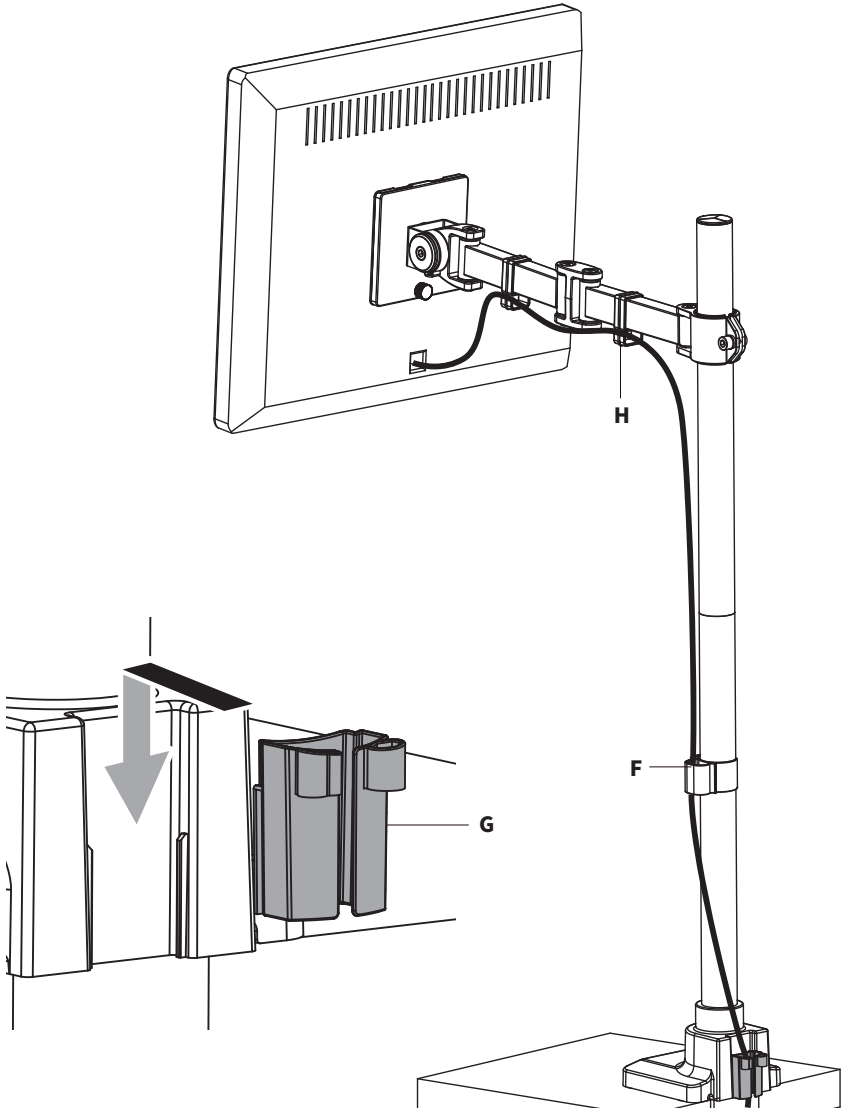



Need Help? Get In Touch

Monday-Friday from 7:00am-7:00pm CST



help@vivo-us.com



www.vivo-us.com

Chat live with an agent!



309-278-5303



VIVO-us @vivo_us