

Assembly Instructions

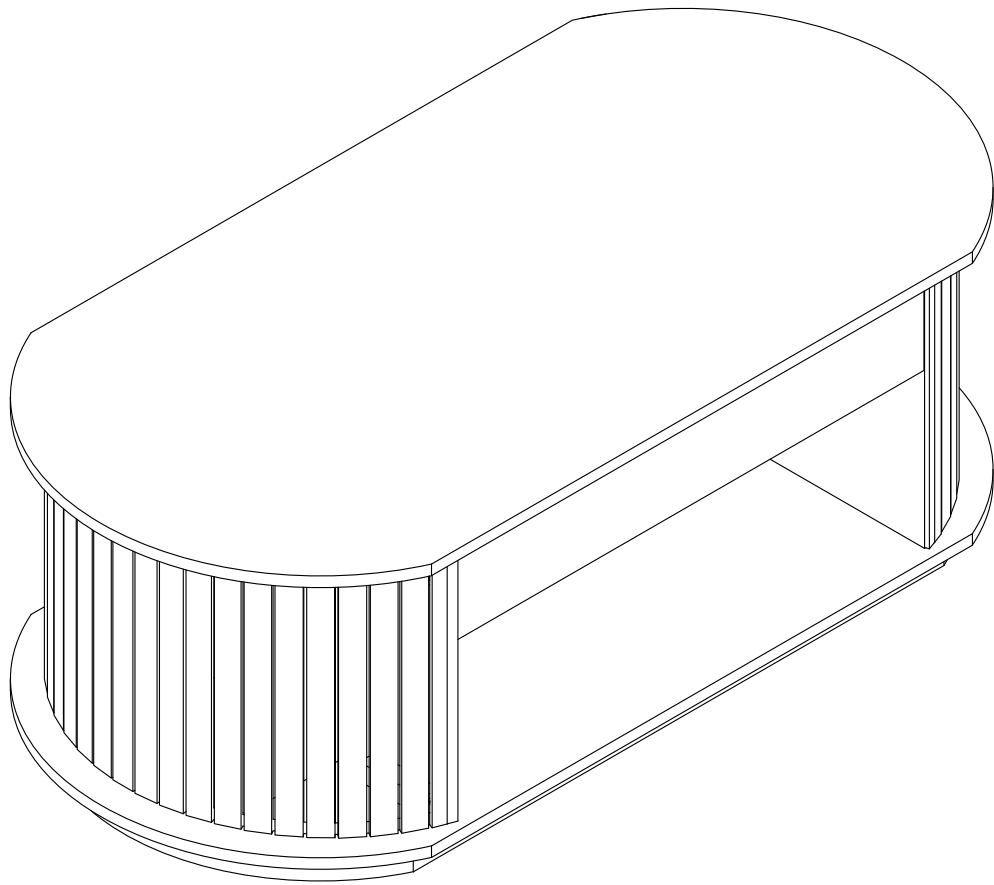

Contact Us

We're here to help you.

Your satisfaction is our top priority. If you encounter any issues with this product, such as missing or damaged parts, we're here to help. Please retain the original packaging and take photos of the packaging and the product, then contact us as soon as possible.

Warm Tips

1. Carefully read these instructions and keep them for future reference.
2. Check the parts list and confirm everything's there before starting assembly.
3. When assembling, put all parts on a soft, smooth surface like a carpet to avoid scratches.
4. Don't fully tighten screws until all parts are confirmed in place to avoid misalignment.

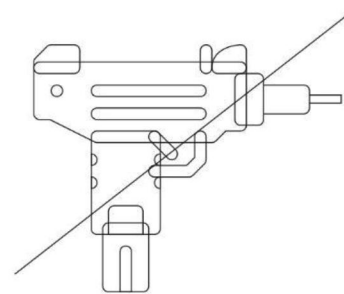
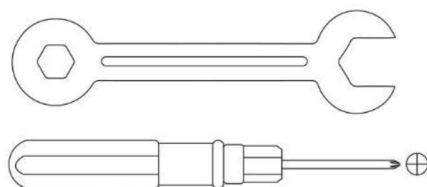
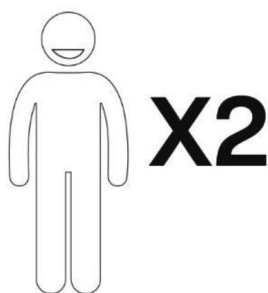

We recommend using hand tools for assembly.



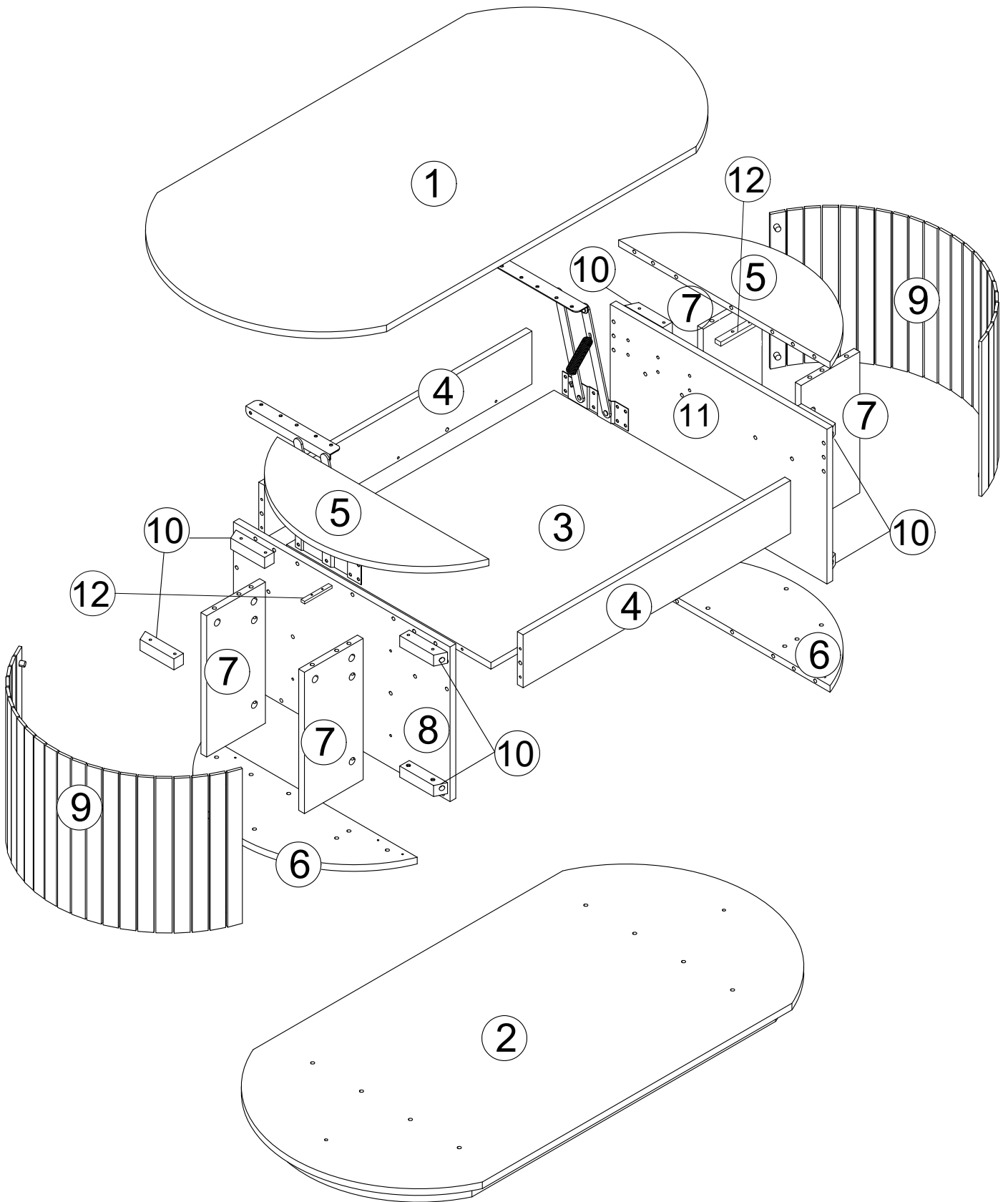



If an electric screwdriver is used, reduce power and torque to avoid damage to the product.



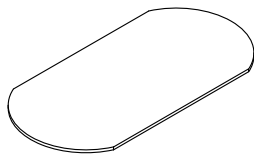
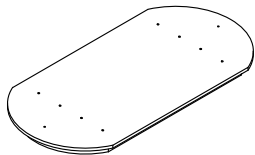
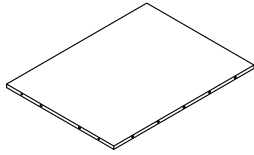
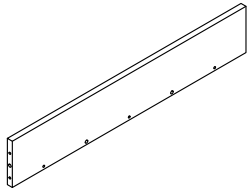
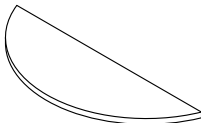
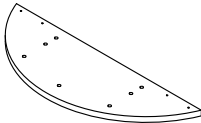

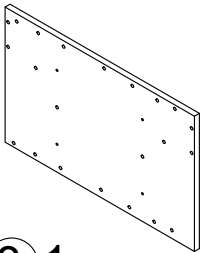
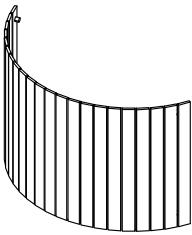

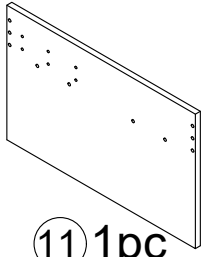

⚠ Caution

Make sure all parts are included. Most board parts are labeled or stamped on the raw edge. Contact us for a free replacement if you encounter any damaged or missing parts.

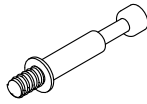
Parts List

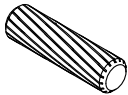
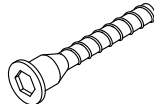
 <p>① 1pc</p>	 <p>② 1pc</p>	 <p>③ 1pc</p>	 <p>④ 2pcs</p>
 <p>⑤ 2pcs</p>	 <p>⑥ 2pcs</p>	 <p>⑦ 4pcs</p>	 <p>⑧ 1pc</p>
 <p>⑨ 2pcs</p>	 <p>⑩ 8pcs</p>	 <p>⑪ 1pc</p>	 <p>⑫ 2pcs</p>

Hardware List

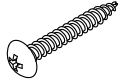
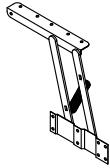
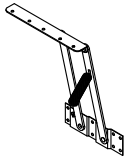
<p>Ax34+2</p>  <p>M6*35mm</p>	<p>Bx34+2</p>  <p>Ø15*12mm</p>	<p>Cx44+2</p>  <p>Ø8*30mm</p>	<p>Dx24+2</p>  <p>Ø7*40mm</p>	<p>Ex1</p> 
<p>Fx34+2</p> 	<p>Gx16</p>  <p>6*12m</p>	<p>Hx2</p>  <p>6*25m</p>	<p>Jx20</p>  <p>4*35mm</p>	<p>Kx1</p> 
<p>Lx1</p> 				

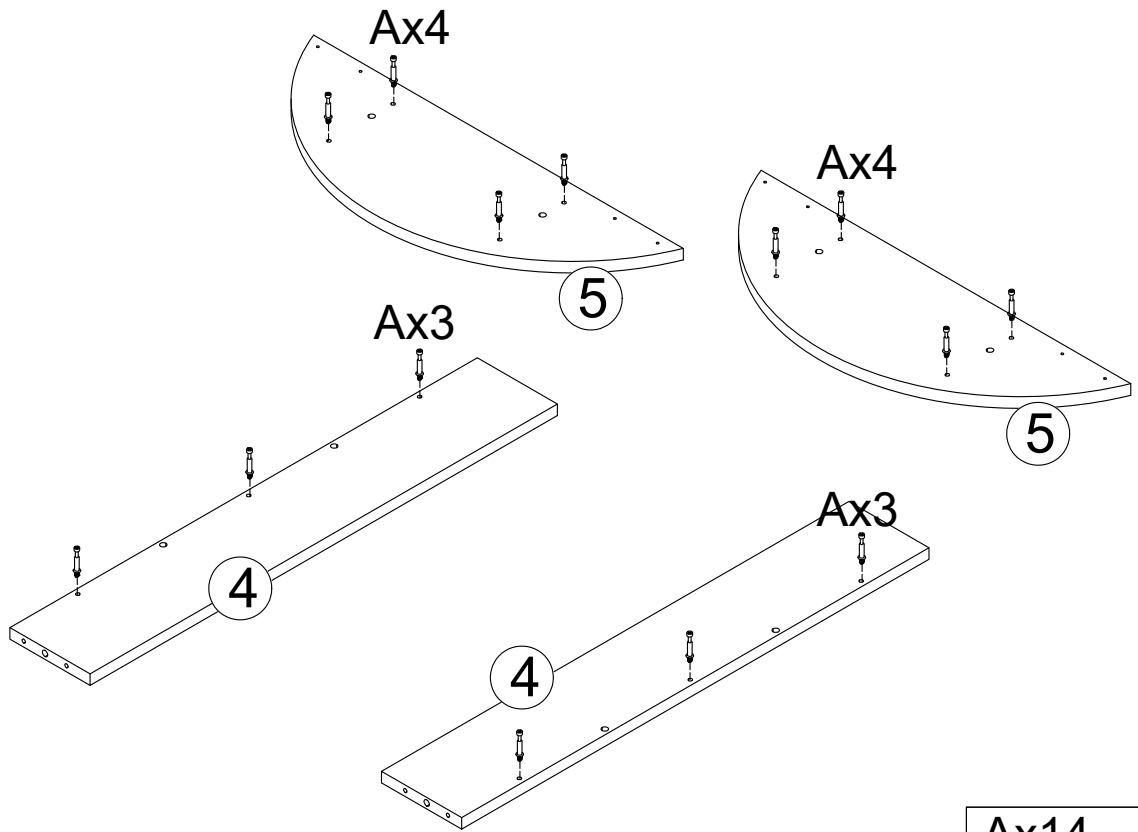

1

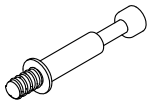

Ax14

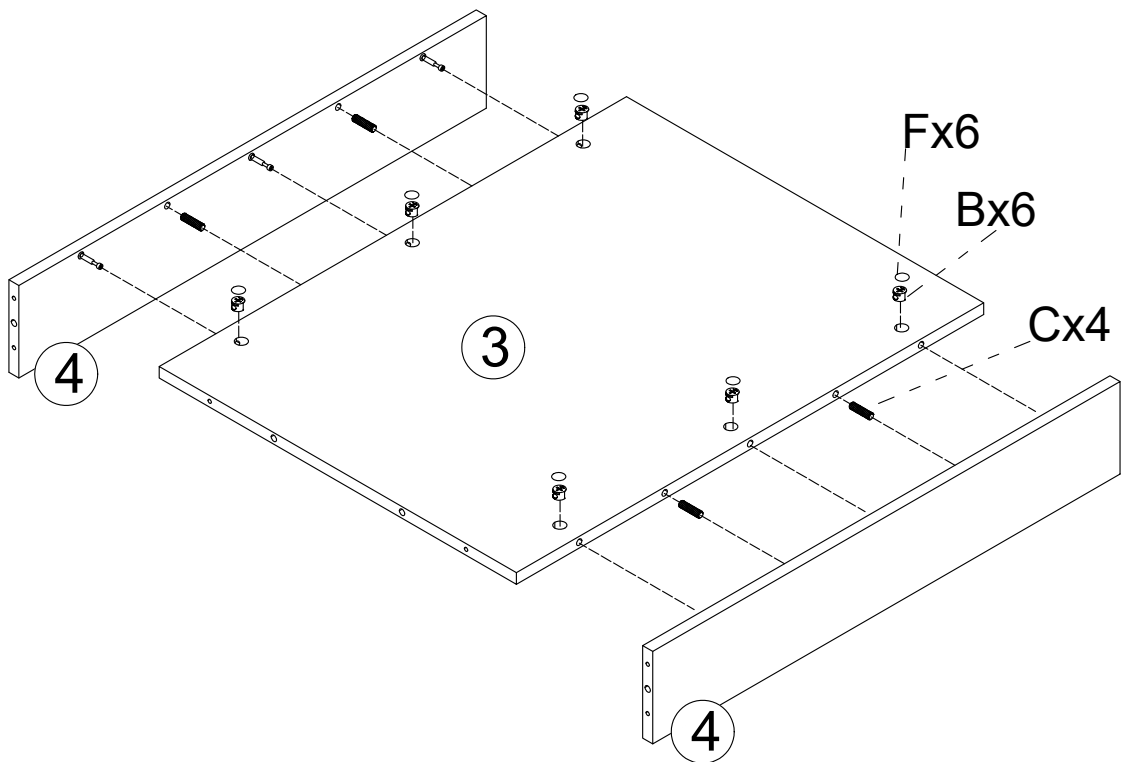
M6*35mm

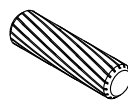

2

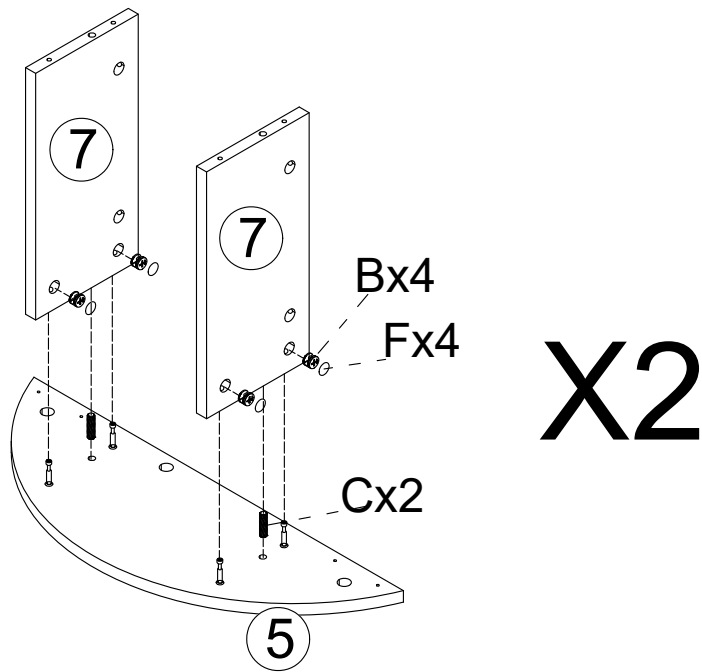

Bx6	Cx4	Fx6
		
Ø15*12mm	Ø8*30mm	



3

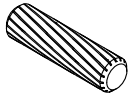

Fx8	Bx8	Cx4
		
	Ø15*12mm	Ø8*30mm

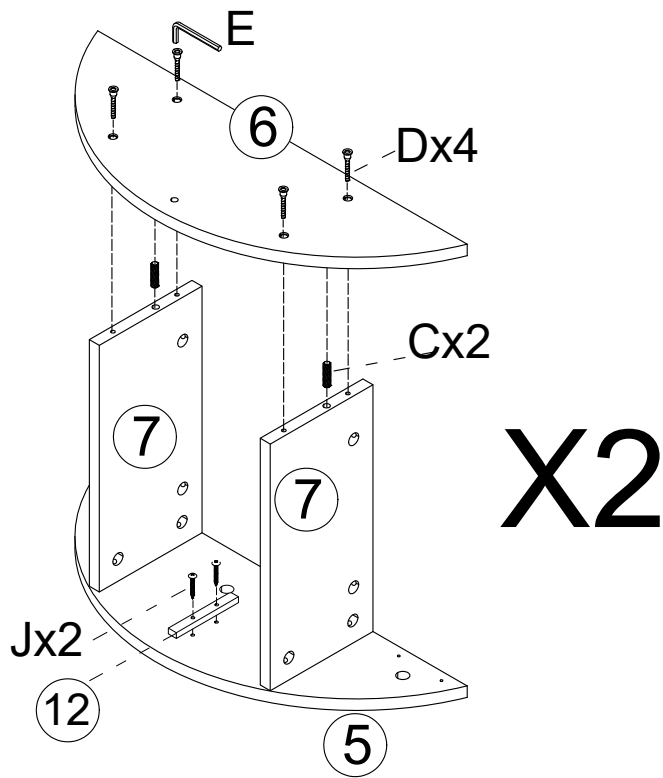
4

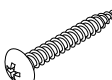
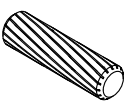
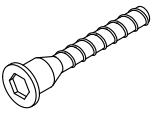

Jx4	Cx4	Dx8	Ex1
			
4*35mm	Ø8*30mm	Ø7*40mm	

5

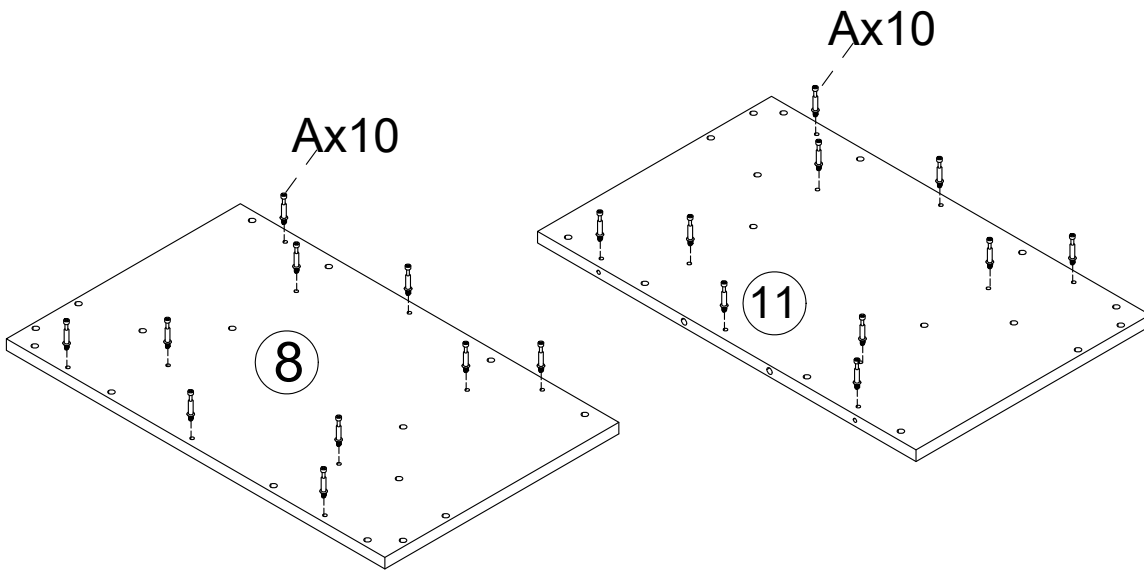

Ax20

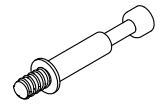

M6*35mm

6

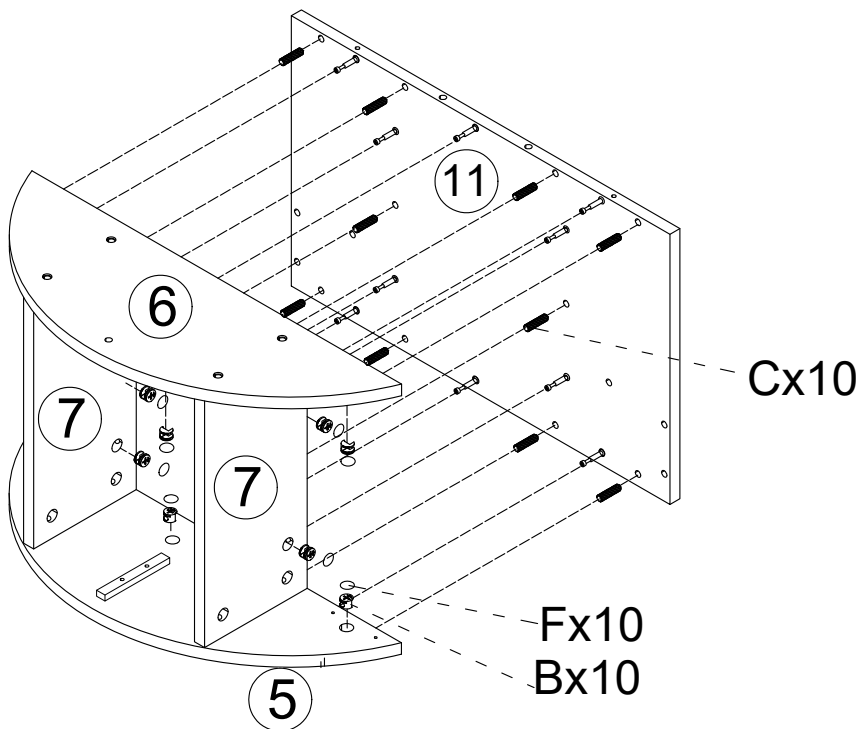

Fx10



Bx10



Ø15*12mm

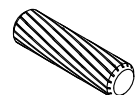

Cx10



Ø8*30mm

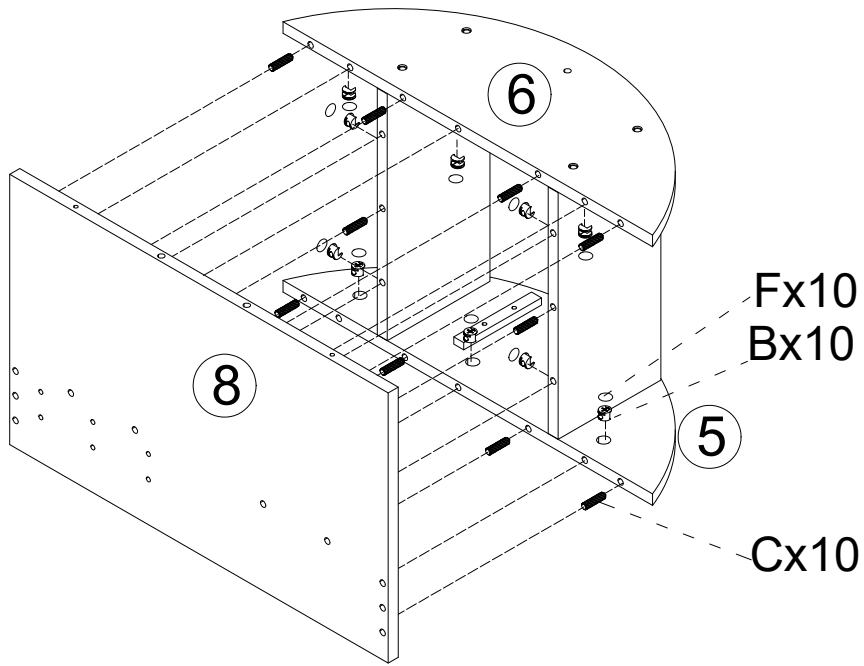

7

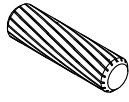

Fx10	Bx10	Cx10
		
	Ø15*12mm	Ø8*30mm

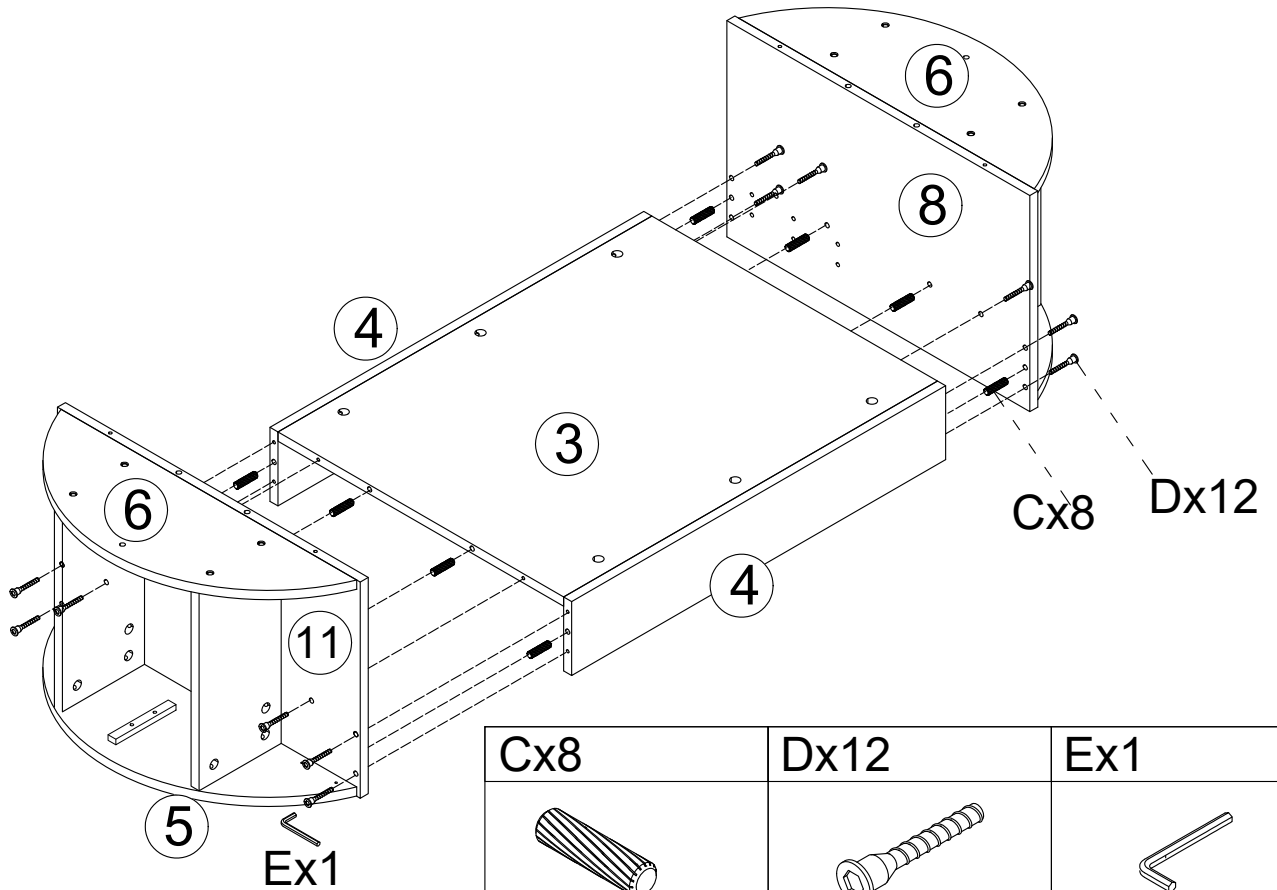
8

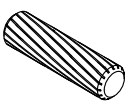
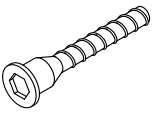

Cx8	Dx12	Ex1
		
Ø8*30mm	Ø7*40mm	

9

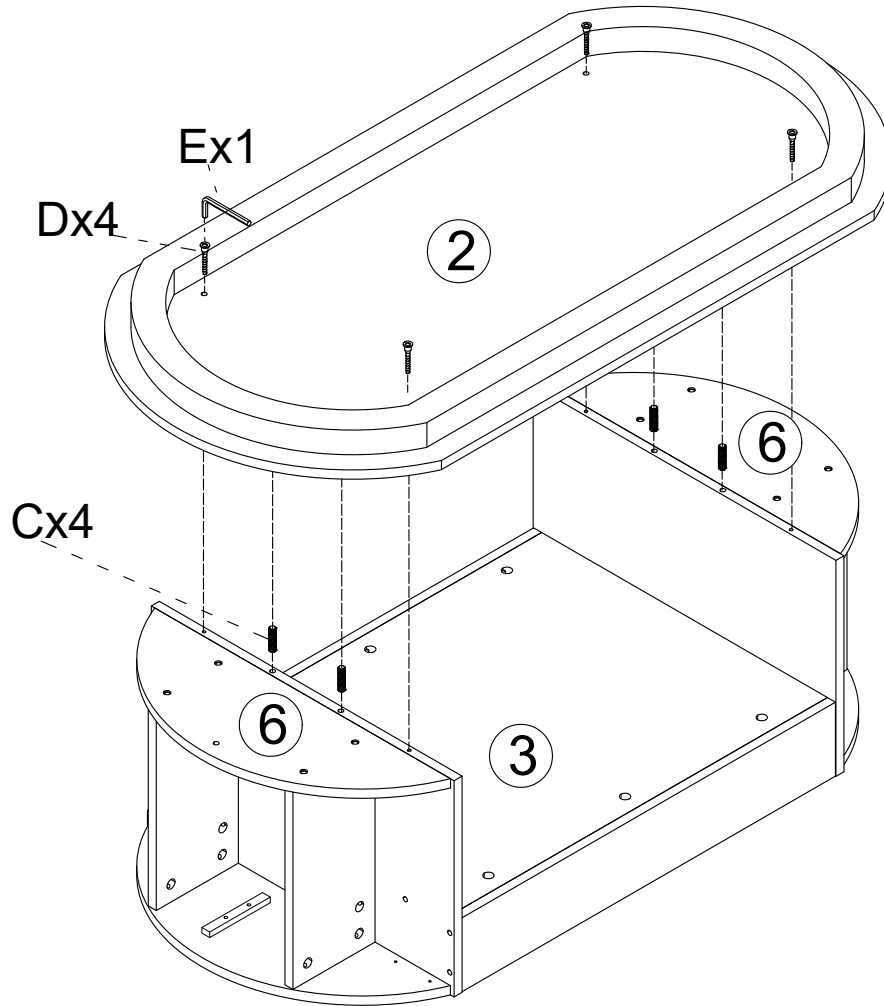

Cx4

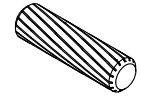

Ø8*30mm

Ex1

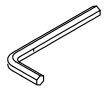

Dx4

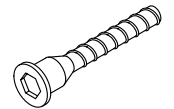

Ø7*40mm

10

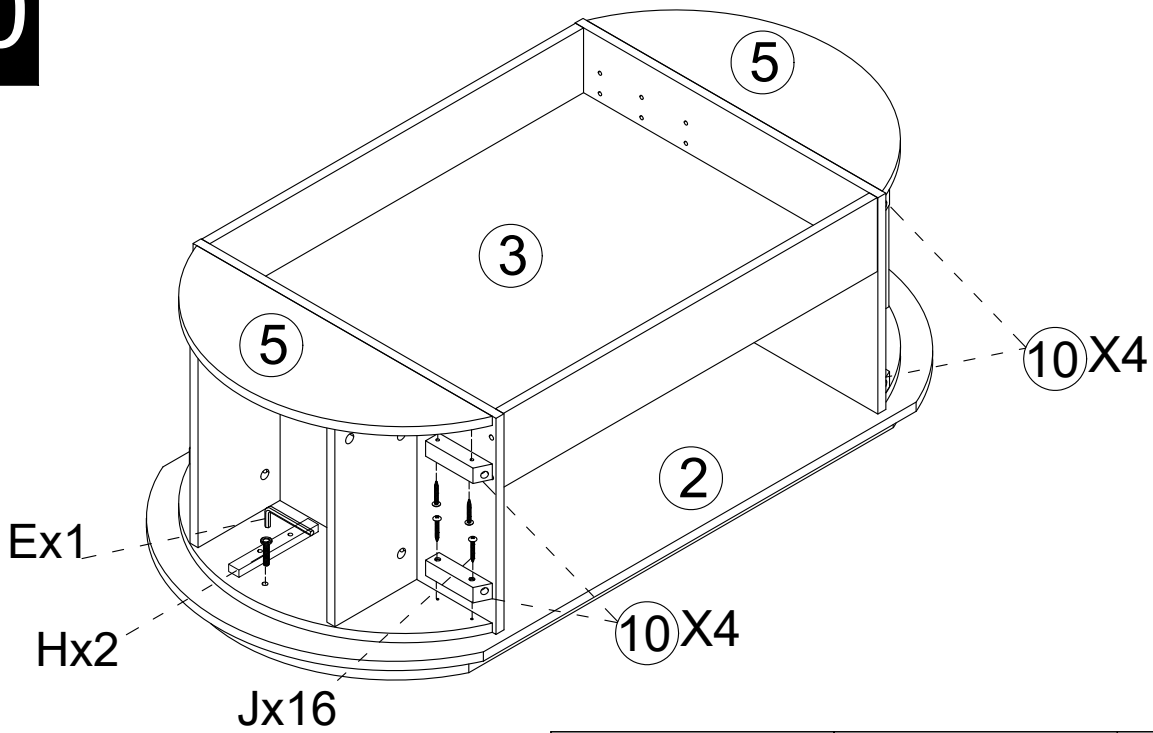

Ex1

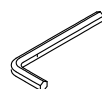

Hx2



6*25m

Jx16

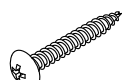

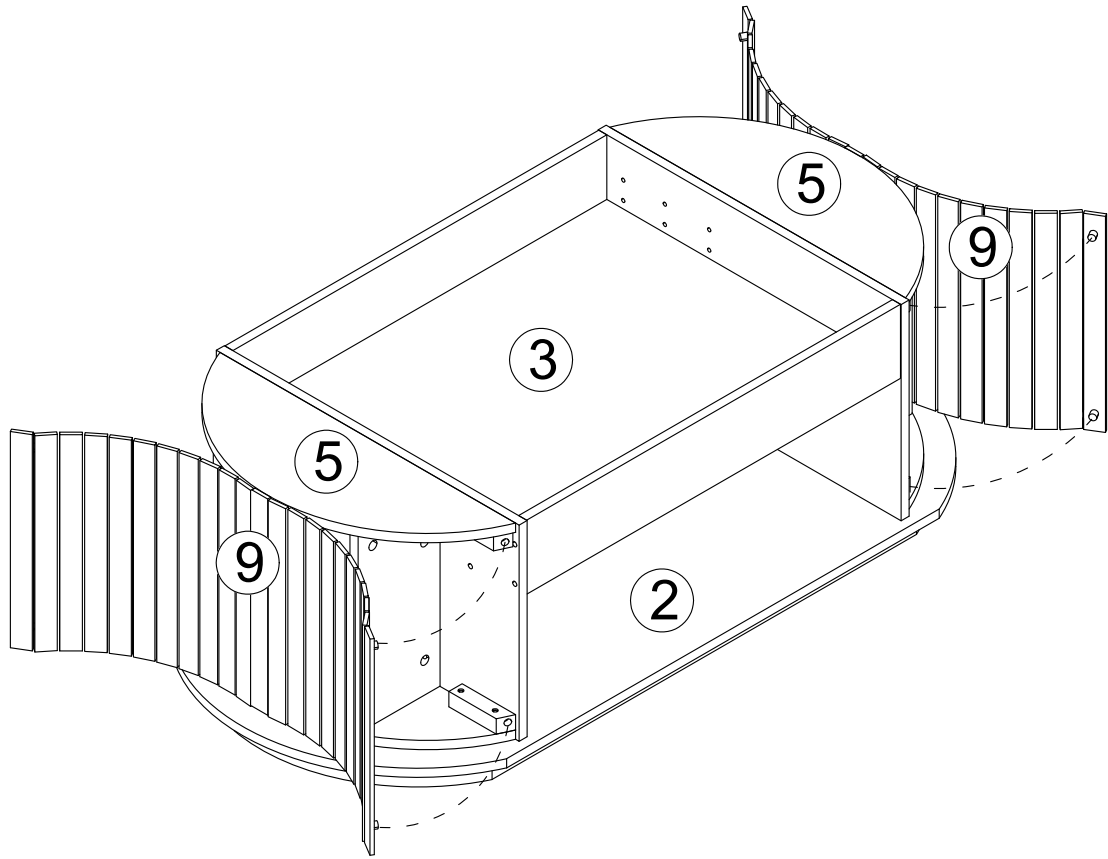

4*35mm

11

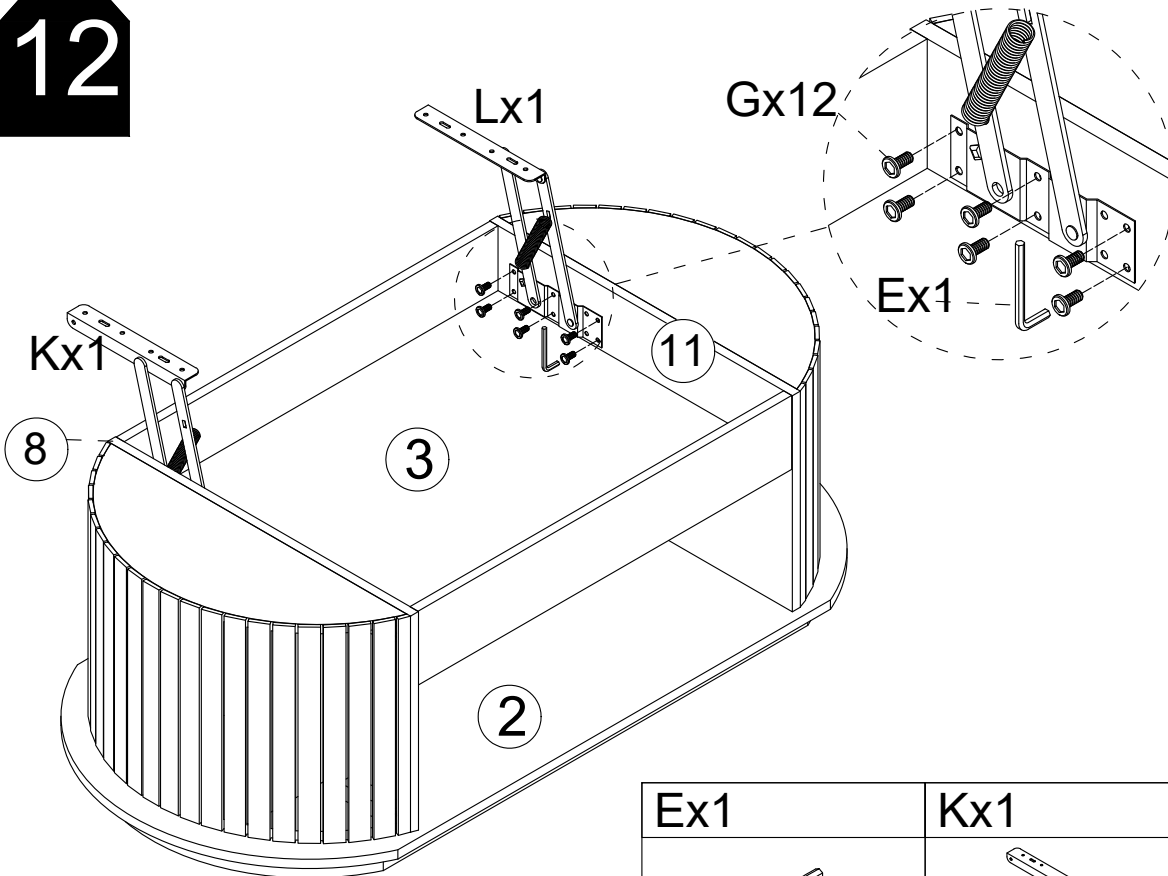

12



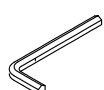
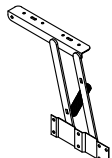
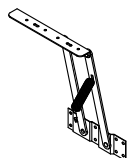

Gx12

6*12m

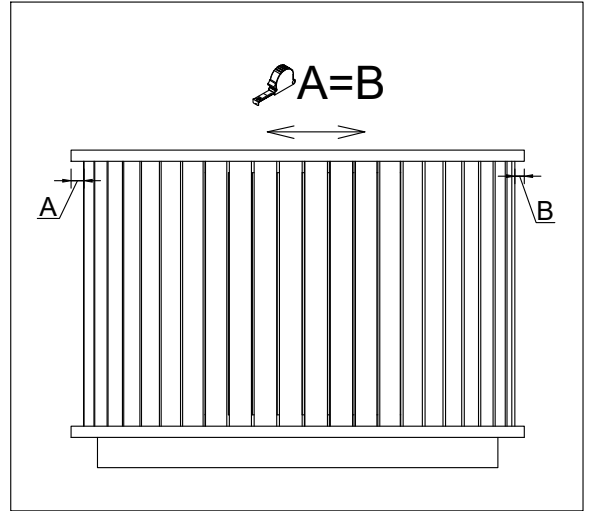
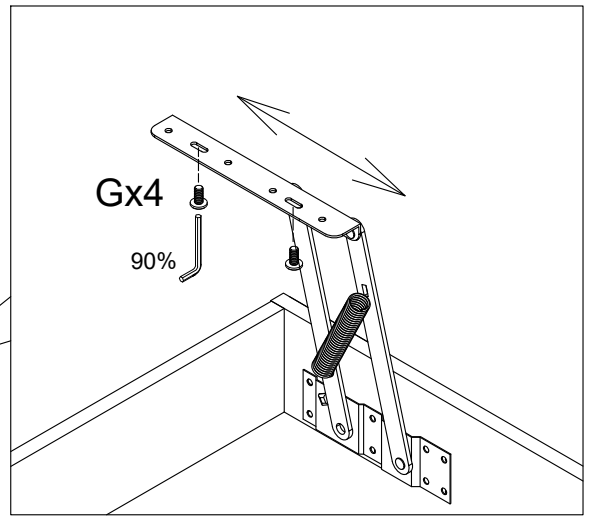
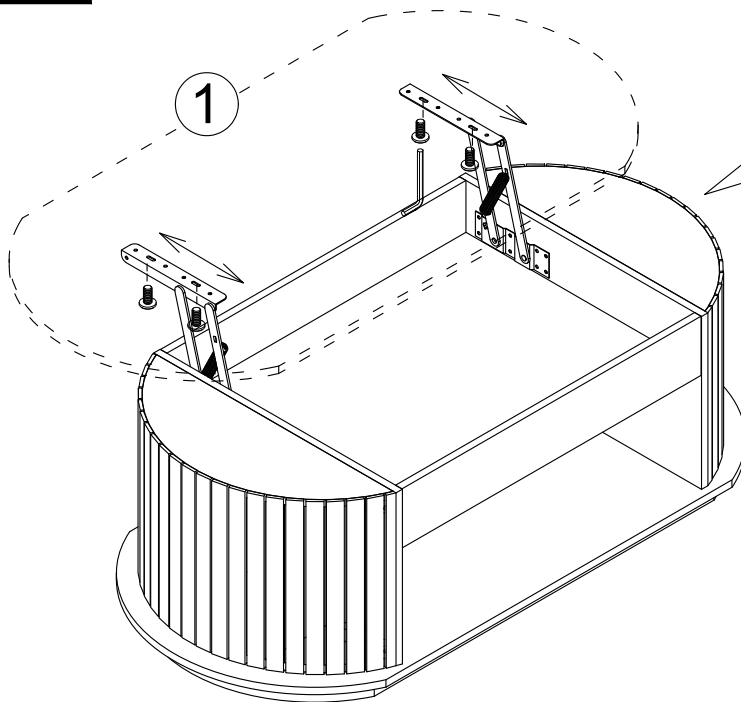
Ex1	Kx1	Lx1
		

13



Gx4	Ex1
	
6*12mm	

14

