

ARMCHAIR

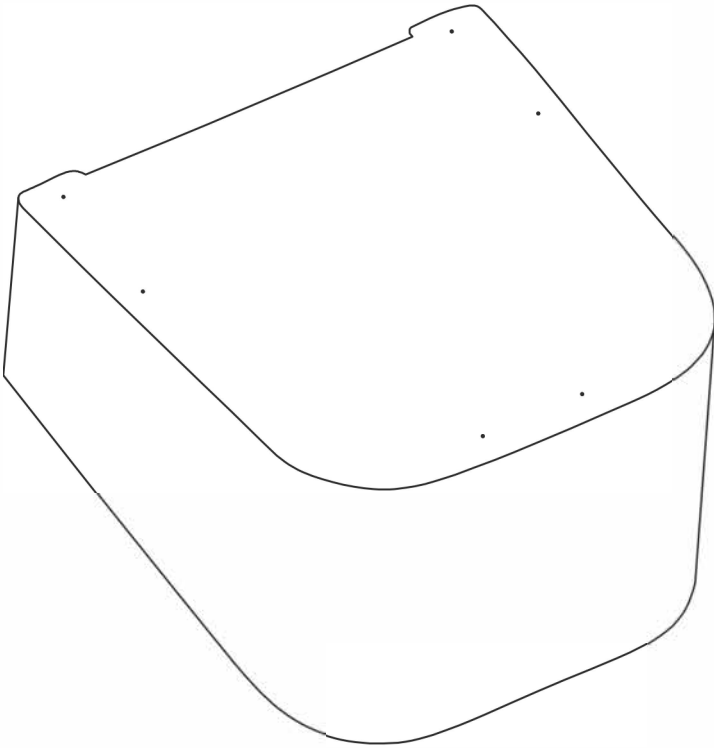

1st process: The armchair removed from the packaging is turned upside down. The feet are aligned with the holes marked under the armchair

LEG ASSEMBLY

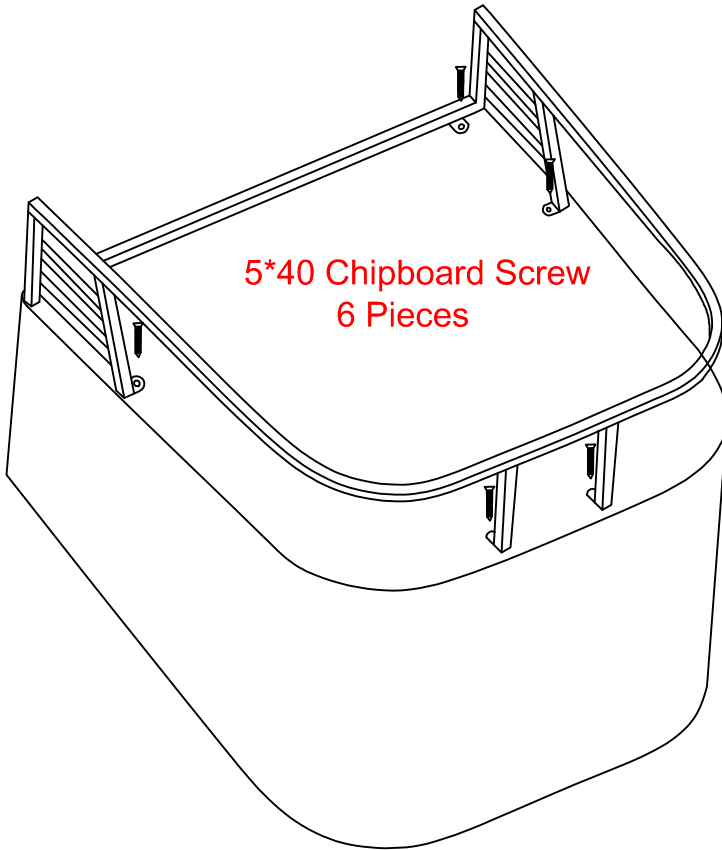

2nd process: The leg mounting holes are aligned in the marked places as seen in the figure. The leg assembly is completed with 6 pieces 5*40 chipboard screws