

ASSEMBLY INSTRUCTION

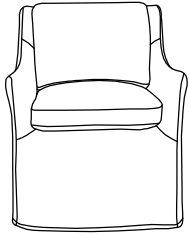

SLIPCOVER DINING CHAIR

Components



A
X1

Hardware

NO.	PICTURE	DESCRIPTION	SPEC.	QTY.
a		Wrench	M14	1
b		Caster	Ø50	4

Assembly steps

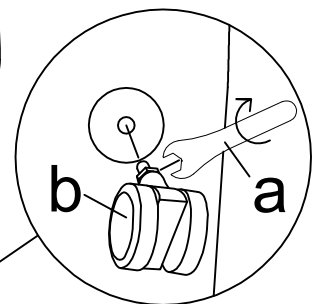
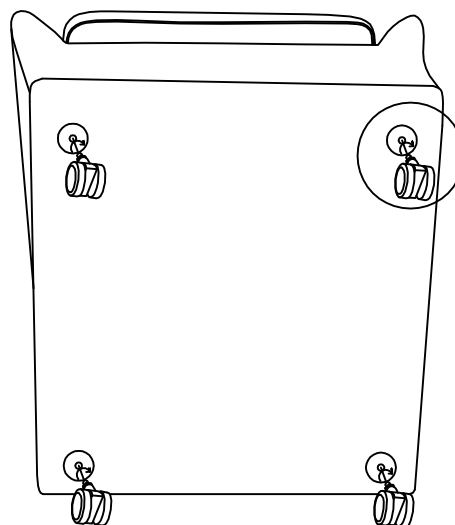
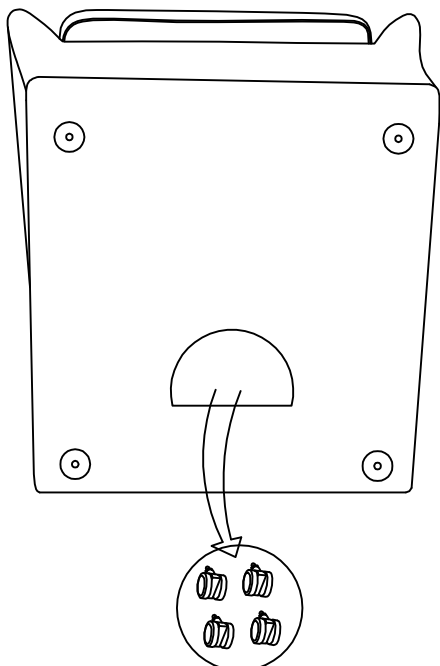
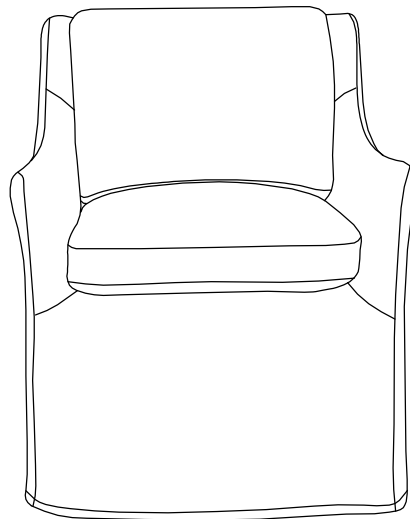

ASSEMBLY INSTRUCTION

SLIPCOVER DINING CHAIR

Components

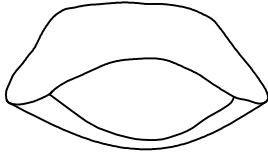

A
X1

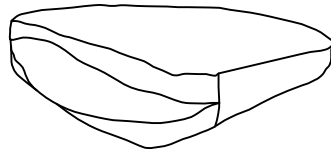

B
X1

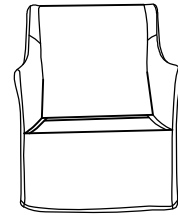

C
X1

Assembly steps

①

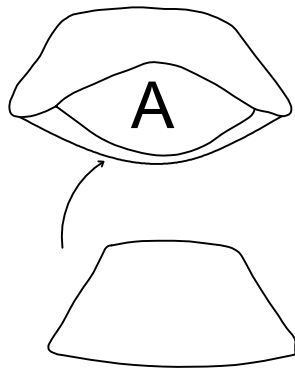

back cushion insert

②

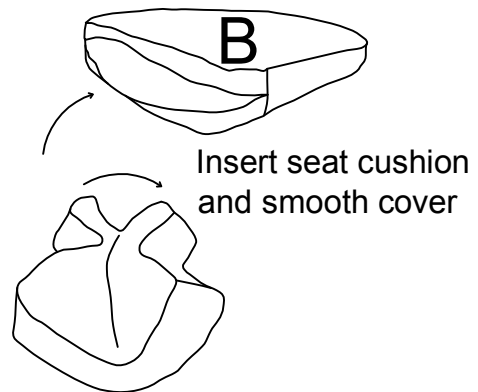

seat cushion insert

③

Remove the protective strips from Velcro for fixing

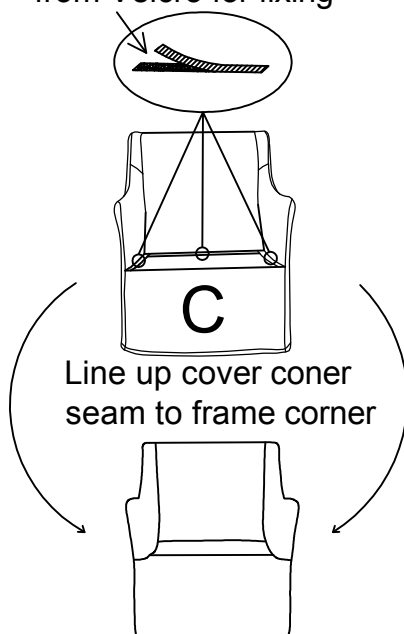

frame w/o cover

④

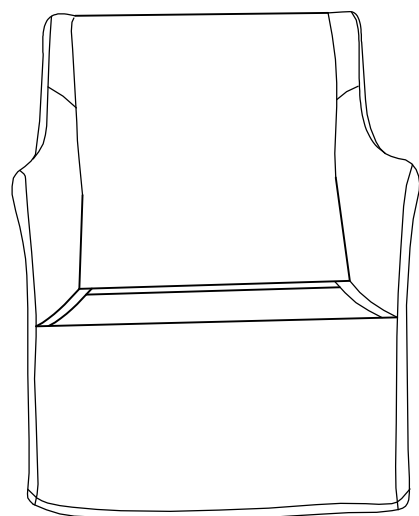

Suggest leaving 0.5" clearance from cover to floor