

Notice:

1. Follow the installation instructions. Please confirm all accessories are preset before installation.
2. Do not fully tighten screws during initial assembly. Gently adjust the board to make them level. Only tighten after all pieces are correctly assembled.
3. If you encounter any problems during installation, refer to two solutions: Follow the installation video tutorial on the Amazon product page or contact our customer service.

Beachten:

1. Befolgen Sie die Installationsanweisungen. Bitte bestätigen Sie vor der Installation, dass alle Zubehörteile voreingestellt sind.
2. Ziehen Sie die Schrauben bei der Erstmontage nicht vollständig an. Stellen Sie das Board vorsichtig so ein, dass es eben ist. Erst festziehen, wenn alle Teile richtig zusammengesetzt sind.
3. Wenn während der Installation Probleme auftreten, finden Sie zwei Lösungen: Befolgen Sie das Installationsvideo-Tutorial auf der Amazon-Produktseite oder wenden Sie sich an unseren Kundendienst.

Remarques:

1. Suivez les instructions d' installation. Assurez-vous que toutes les pièces jointes sont prépositionnées avant l' installation svp.
2. Ne serrez pas complètement les vis lors de l' installation initiale. Ajustez doucement les plaques pour les niveler. Serrez seulement après que tous les composants ont été assemblés correctement.
3. Si vous rencontrez des problèmes lors de l' installation, référez-vous à deux solutions: suivez le didacticiel vidéo d' installation sur la page de produit Amazon ou contactez notre service à la clientèle



Nota:

1. Seguire le istruzioni di installazione. Assicurarsi che tutti gli accessori siano preregolati prima dell' installazione.
2. Non avvitare completamente le viti durante l' assemblaggio iniziale. Regolare delicatamente le assi per livellarle. Avvitare solo quando tutti i pezzi sono assemblati correttamente.
3. Se incontri qualsiasi problema durante l' installazione, fai riferimento a queste due soluzioni: Segui il video tutorial d' installazione sulla pagina Amazon del prodotto o contatta il nostro servizio clienti.

Aviso:

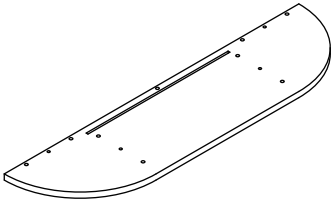
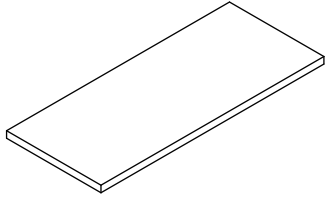
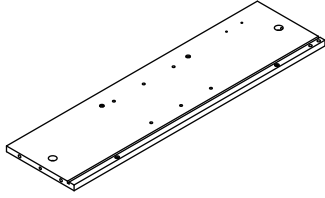
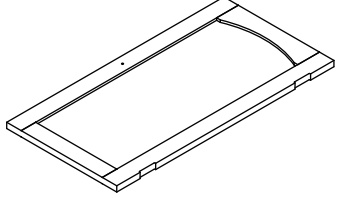
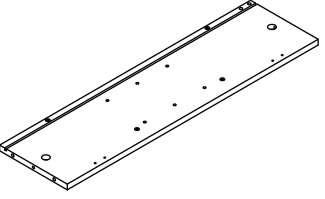
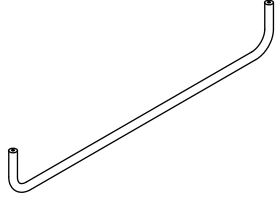
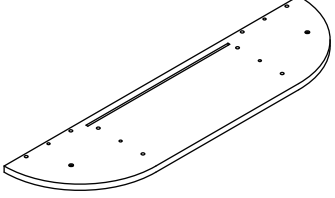
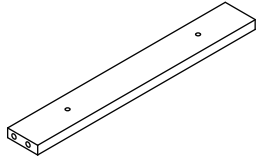
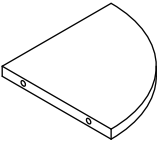
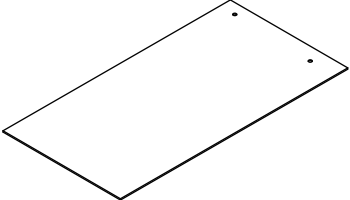
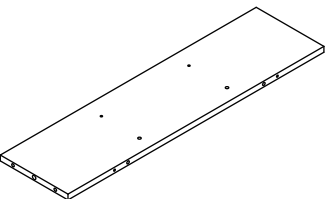
1. Siga las instrucciones de instalación. Revise que todos los accesorios estén en condiciones antes de la instalación.
2. No apriete los tornillos por completo durante la instalación inicial. Ajuste suavemente el tablero para nivelar. Apriete por completo una vez que todas las piezas estén colocadas correctamente.
3. Si encuentra algún problema durante la instalación: siga el video tutorial de instalación en la página del producto en Amazon, o póngase en contacto con nuestro servicio de atención al cliente.

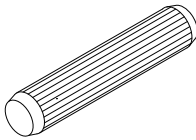
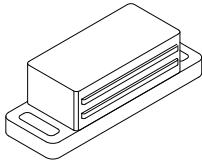
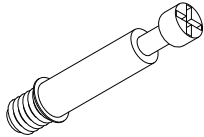
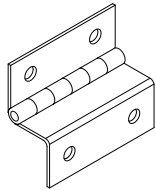
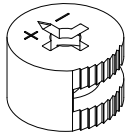
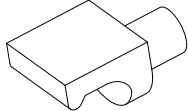
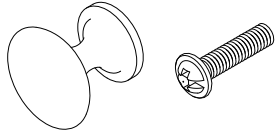
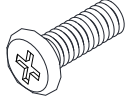
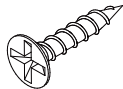
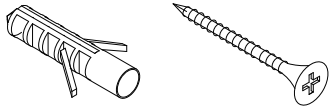
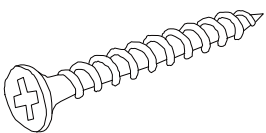
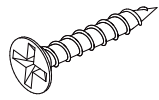
Item no. Nr. N° d' article Articolo n. N° de artículo	Reference image Referenzbild Image de référence Immagine di riferimento Imagen de referencia	Qty. Menge Qté Qtà Cantidad	Item no. Nr. N° d' article Articolo n. N° de artículo	Reference image Referenzbild Image de référence Immagine di riferimento Imagen de referencia	Qty. Menge Qté Qtà Cantidad
①		X1	⑦		X1
②		X1	⑧		X1
③		X1	⑨		X1
④		X1	⑩		X1
⑤		X4	⑪		X1
⑥		X2			

Item no. Nr. N° d' article Articolo n. N° de artículo	Reference image Referenzbild Image de référence Immagine di riferimento Imagen de referencia	Qty. Menge Qté Qtà Cantidad	Item no. Nr. N° d' article Articolo n. N° de artículo	Reference image Referenzbild Image de référence Immagine di riferimento Imagen de referencia	Qty. Menge Qté Qtà Cantidad
(A)	 M6*30	X33+3	(H)	 X1	
(B)	 M6*35	X8	(I)	 M41*15	X2
(C)	 M15*9.5	X8	(J)	 X4	
(D)	 M4*16	X1	(K)	 M6*16	X2
(E)	 M3*12	X10+1	(L)	 M3.5*40	X2
(F)	 M4*30	X12+1	(M)	 M3*14	X2
(G)	 X1	X1	(N)	 X10	

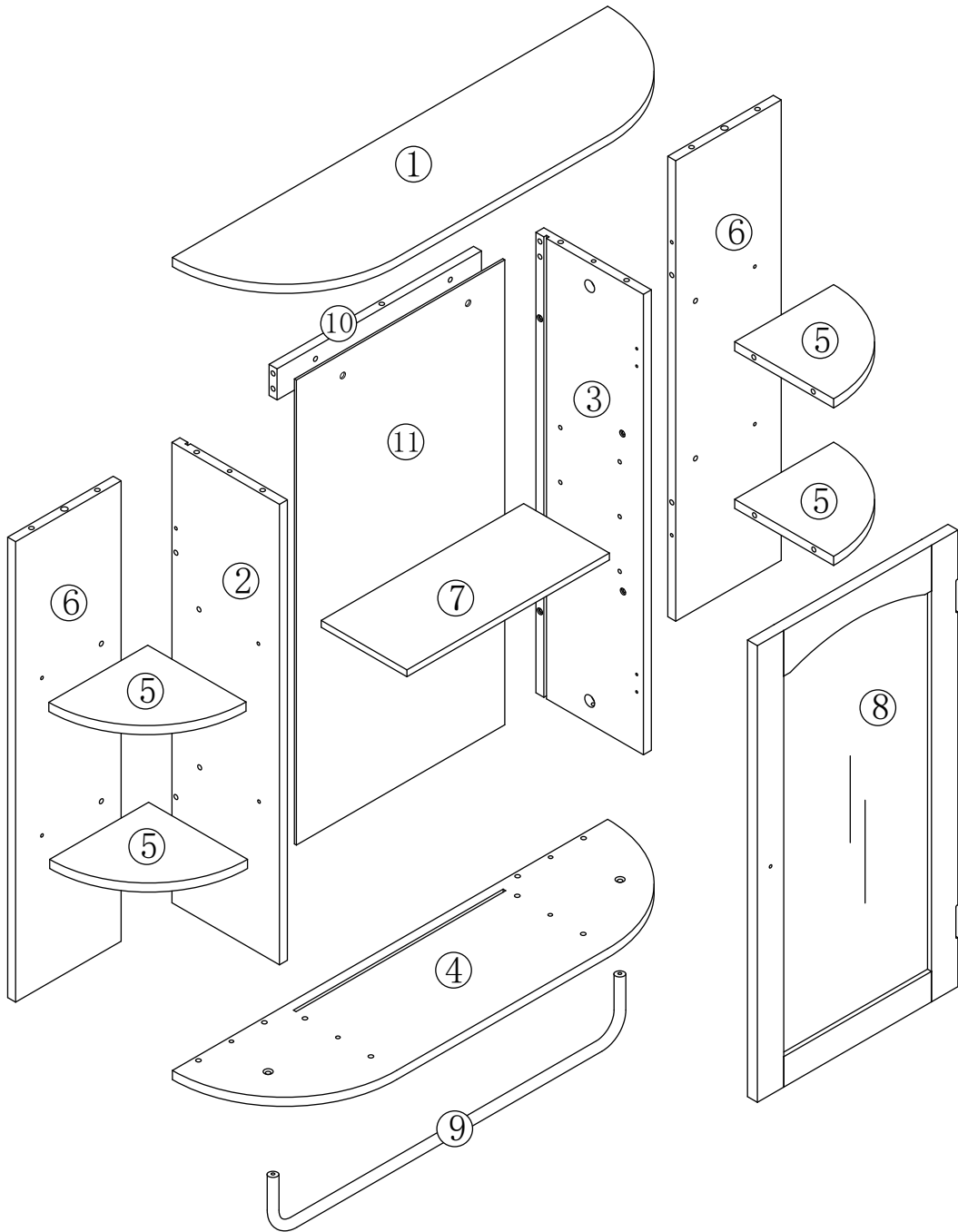

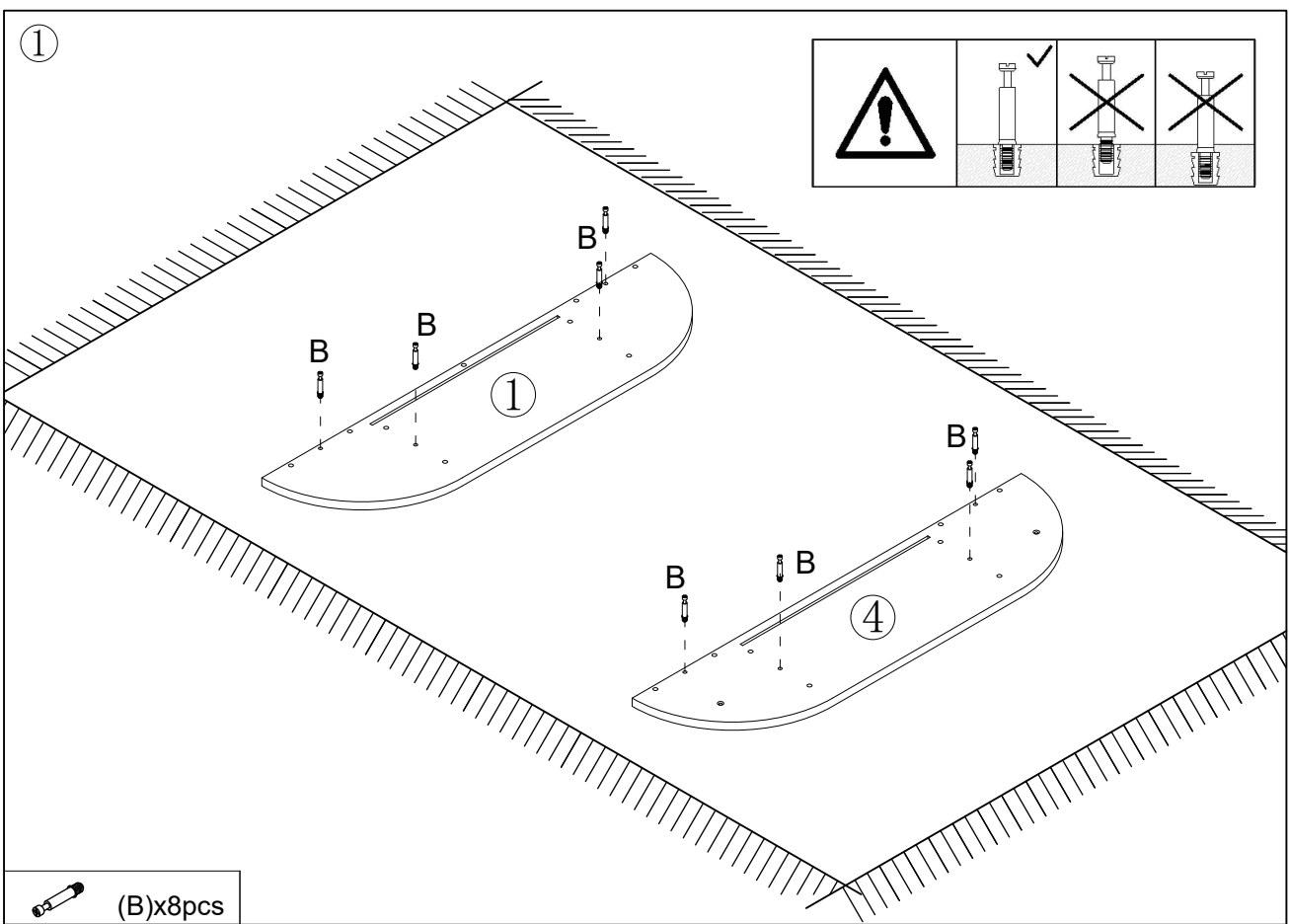

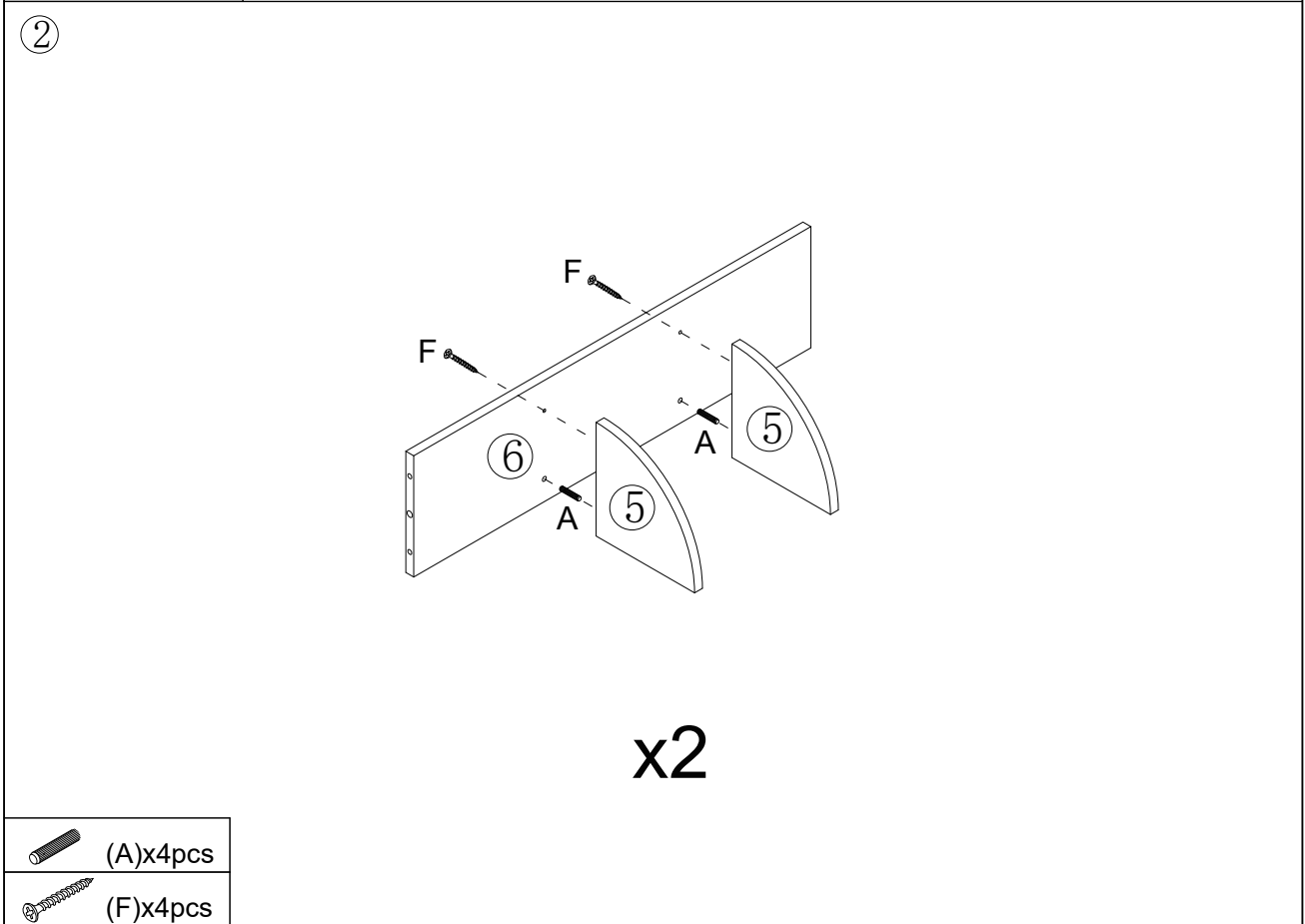

 (B)x8pcs



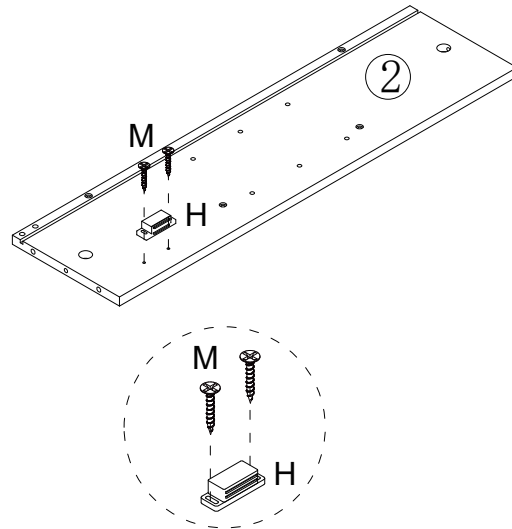

③

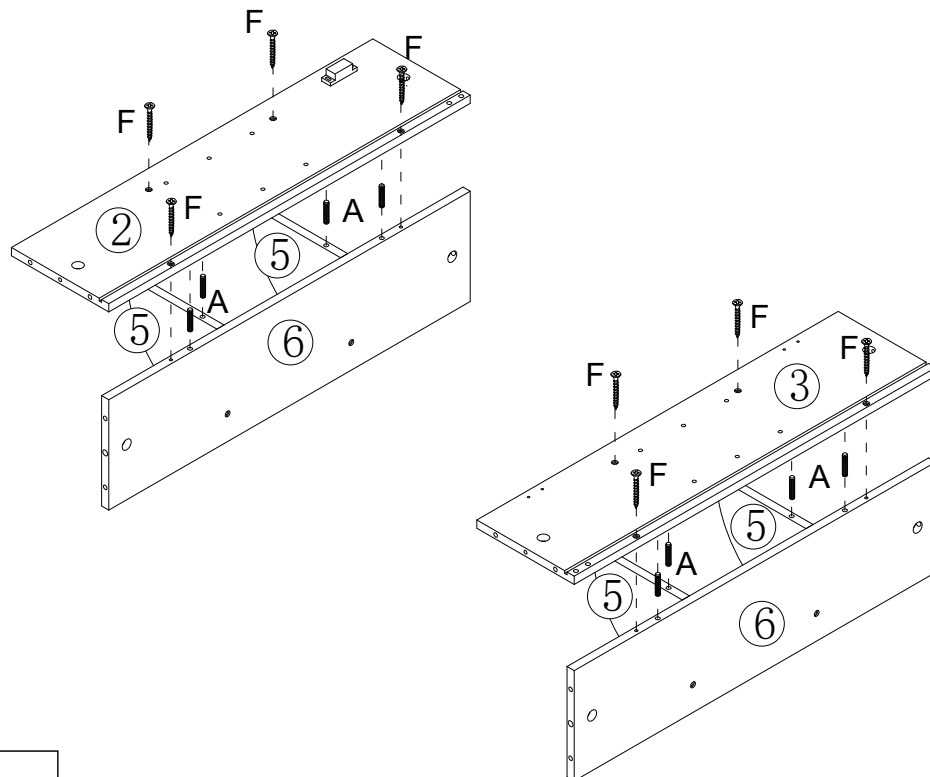

- | | |
|---|----------|
|  | (H)x1pc |
|  | (M)x2pcs |

④



- | | |
|---|----------|
|  | (A)x8pcs |
|  | (F)x8pcs |

⑤

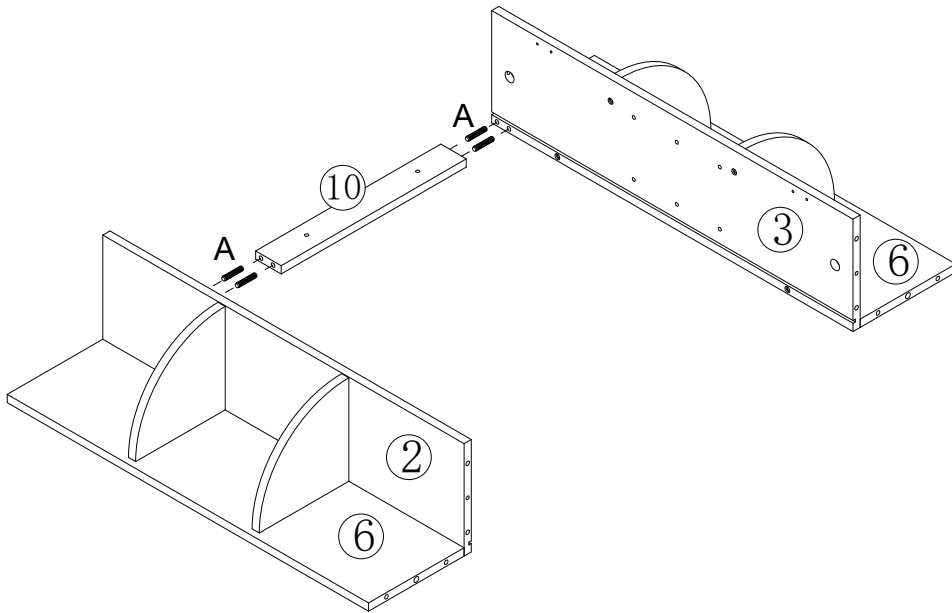

 (A)x4pcs

⑥

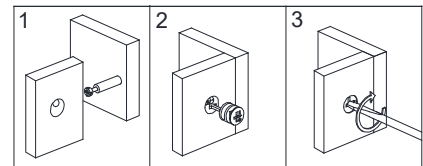
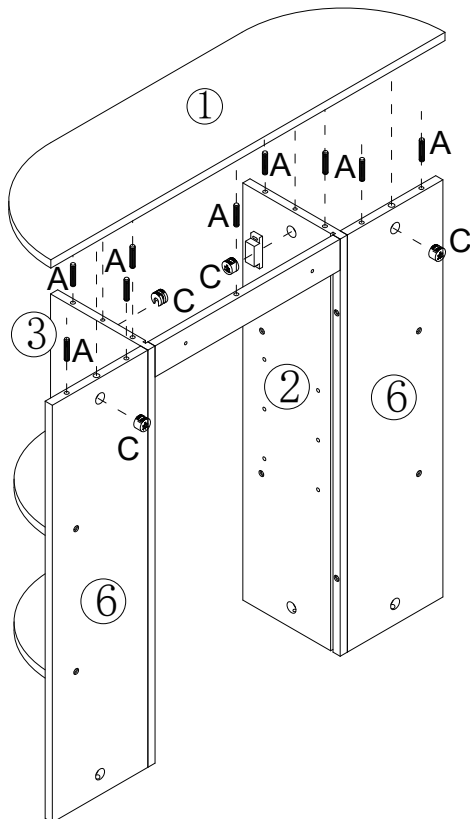

Cam Lock Fastening System

Cam-Lock-Befestigungssystem

Système de fixation à verrouillage par came

Sistema di fissaggio a chiavistello a camma

Sistema de sujeción con bloqueo de leva

 (A)x9pcs

 (C)x4pcs

7

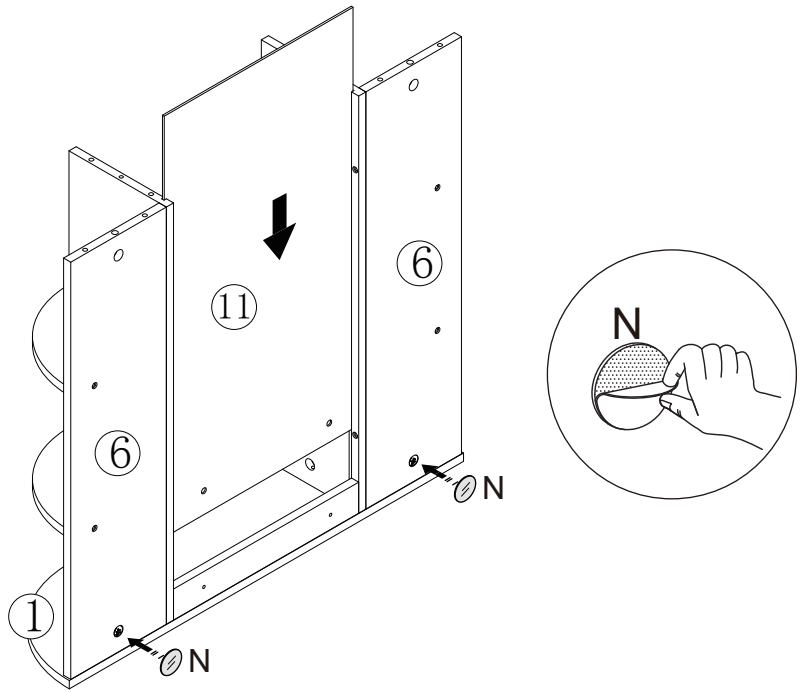

(N)x2pcs

8

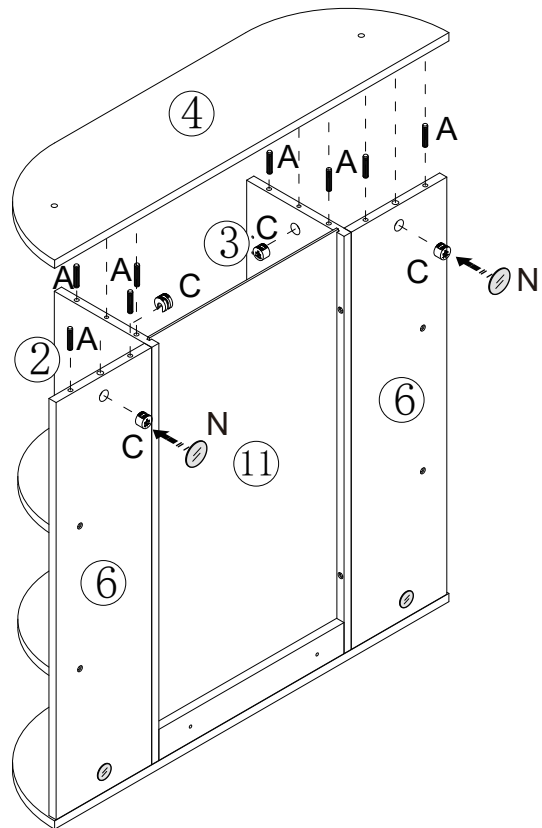





(A)x8pcs

(C)x4pcs

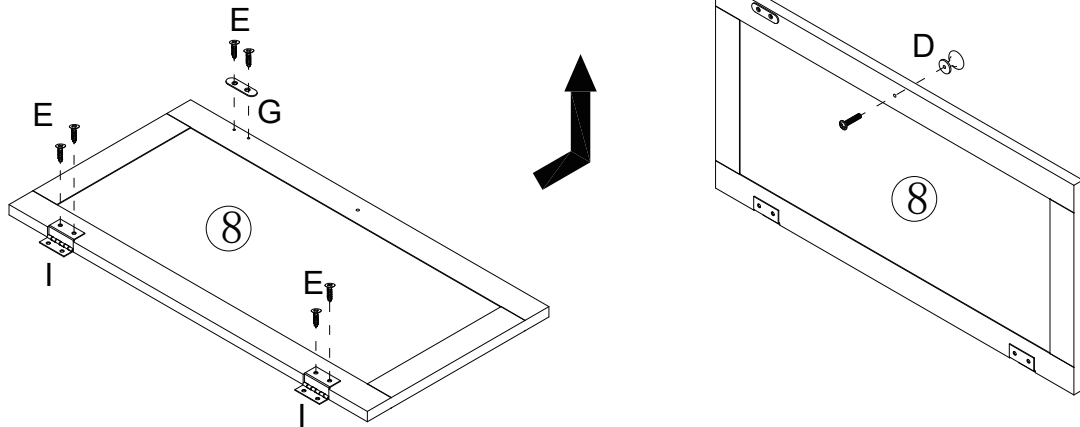
(N)x2pcs

9



-  (D)x1pcs
-  (E)x6pcs
-  (G)x1pc
-  (I)x2pcs

10

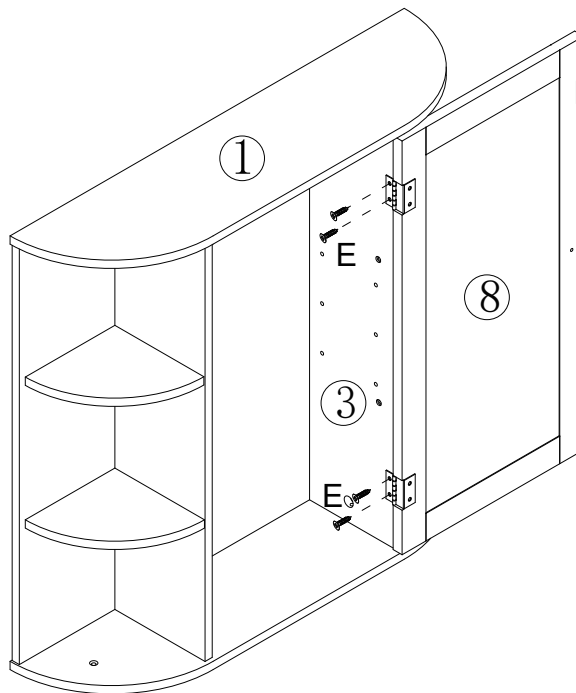

-  (E)x4pcs

11

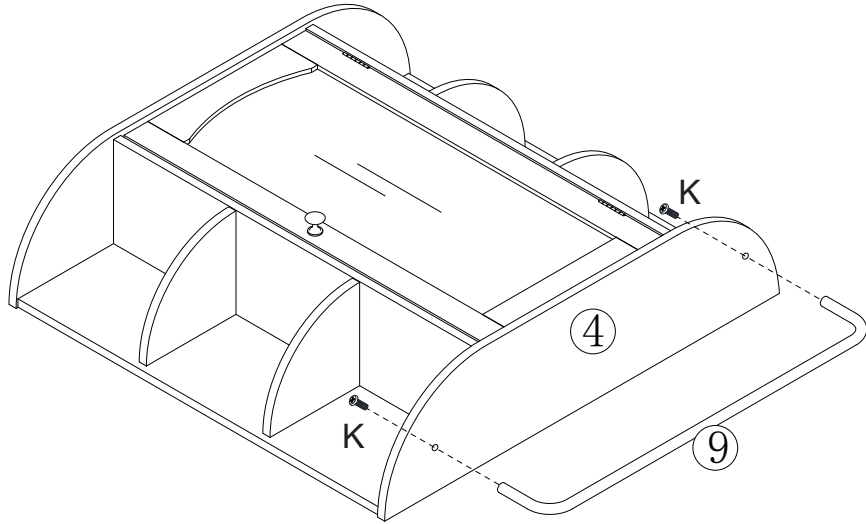

 (K)x2pcs

12

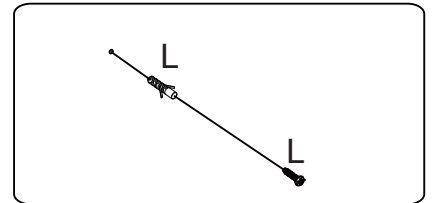
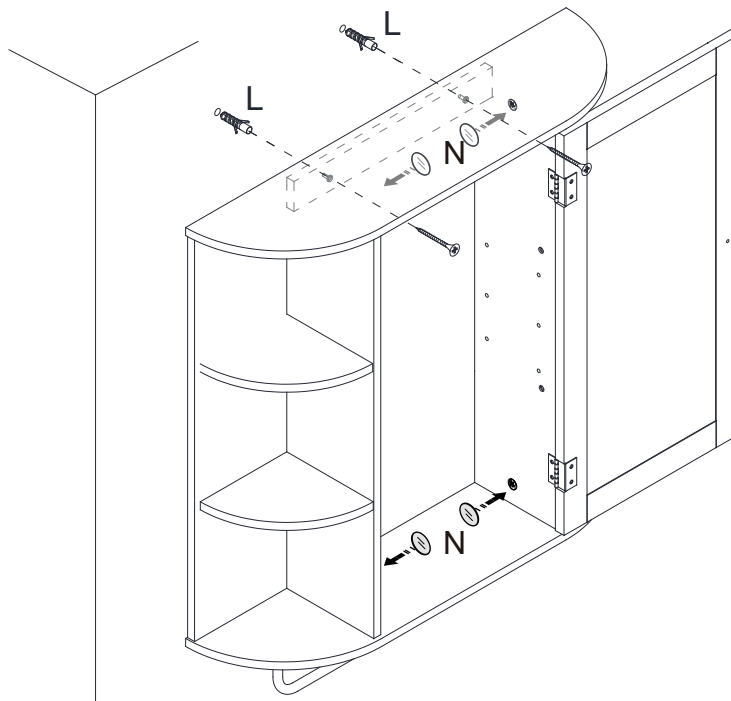
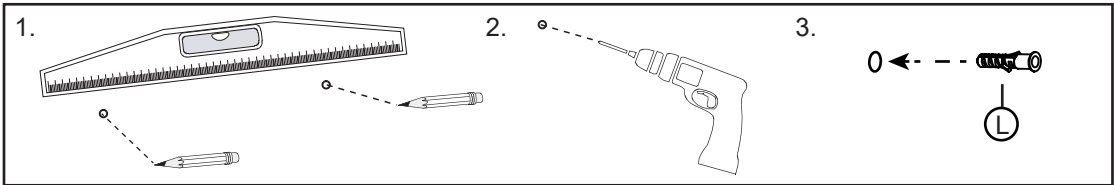

OPTION #1
OPTION #1
OPTION #1
OPTION #1
OPTION #1

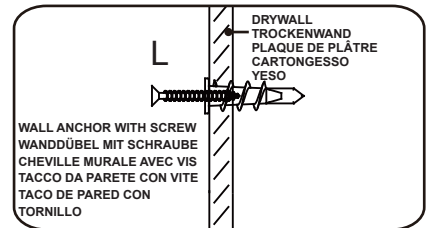

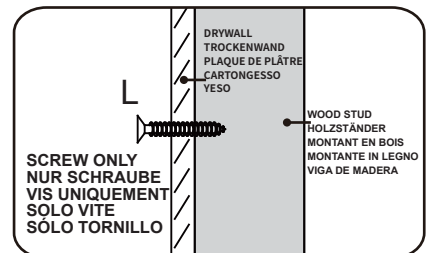

WALL ANCHOR WITH SCREW
WANDDÜBEL MIT SCHRAUBE
CHEVILLE MURALE AVEC VIS
TACCO DA PARETE CON VITE
TACO DE PARED CON
TORNILLO

OPTION #2
OPTION #2
OPTION #2
OPTION #2
OPTION #2



SCREW ONLY
NUR SCHRAUBE
VIS UNIQUEMENT
SOLO VITE
SOLO TORNILLO

 (L)x2pcs

 (N)x4pcs

13

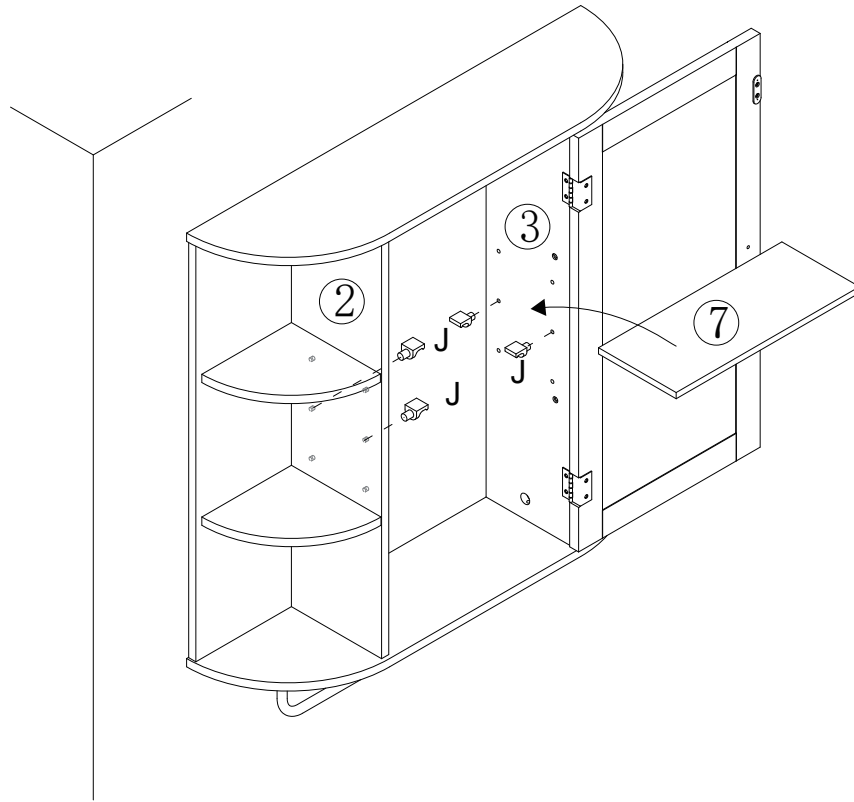

(J)x4pcs

14

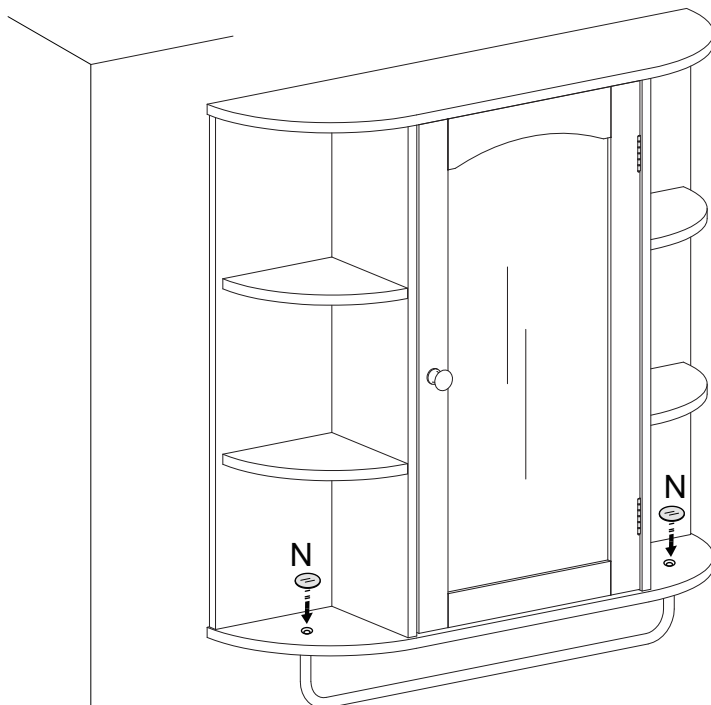

(N)x2pcs

Installation Completed

Installation Abgeschlossen

Installation Complétée

Installazione Completata

Instalación Completada