

Installation Manual



Warning- To reduce the risk of injury, user must read instructions manual carefully.

INSTALLATION NOTES

NOTES:

1. Try to choose hard ground for installation.
2. Prepare installation tools in advance (Rubber hammer and wood).
3. Carefully read this installation manual and confirm the quantity of accessories according to the list.

MODEL AND PARAMETERS











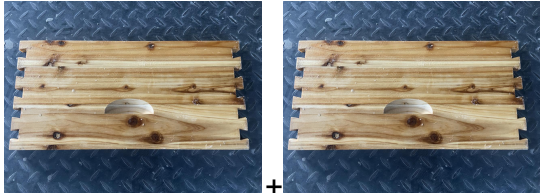

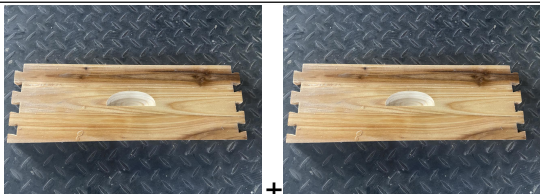
Product size	503mm W x 414mm D x 245mm H
Cabinet material	Cedarwood
Surface treatment	Wax boiling process





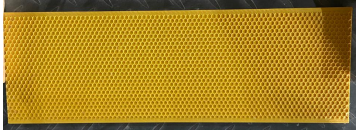

Product size	504mm W x 413mm D x 170mm H
Cabinet material	Cedarwood
Surface treatment	Wax boiling process

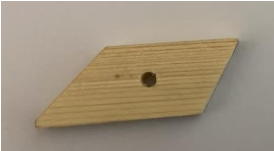
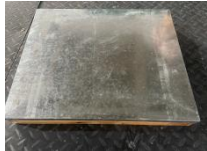
Product size	562mm W x 462mm D x 512mm H
Cabinet material	Cedarwood
Surface treatment	Wax boiling process

Product size	562mm W x 462mm D x 760mm H
Cabinet material	Cedarwood
Surface treatment	Wax boiling process

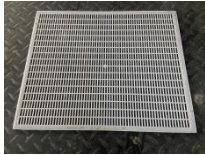
COMPONENTS

 <p>A1 240 Coaming 1(x2)</p>	 <p>B1-1 B1-2 B1 240 Coaming 2(x2)</p>	
 <p>A1 170 Coaming 1(x2)</p>	 <p>B2-1 B2-2 B2 170 Coaming 2(x2)</p>	
 <p>C 170/240 Main frame bar 1(x20)</p>	 <p>D 170/240 Main frame bar 2(x20)</p>	 <p>E1 240 Frame bar (x20)</p>
 <p>E2 170 Frame bar (x20)</p>	 <p>F1 240 Foundation sheet (x20)</p>	 <p>F2 170 Foundation sheet (x10)</p>
 <p>G Handle (x2)</p>	 <p>H Screw M4 x 30 (x2)</p>	 <p>I1 I2 I Window pane (x2)</p>
 <p>J Self-tapping screw M4 x 20 (x4)</p>	 <p>K Small plank (x4)</p>	 <p>L Top Cover (x1)</p>

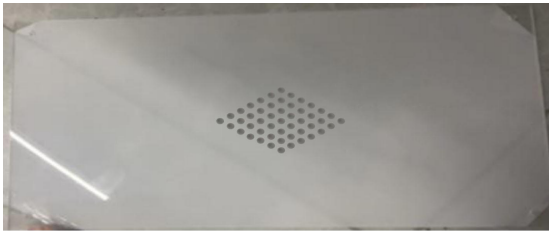
 <p>M Inner Cover (x1)</p>	 <p>N Bottom Board (x1)</p>	 <p>O Queen Excluder (x1)</p>
 <p>P Entrance Reducer (x1)</p>	 <p>Q iron nails (x80)</p>	 <p>R Self-tapping screw M3 12 (x8)</p>
 <p>S Acrylic panel window (x2)</p>		

ASSEMBLY

10 Frame .

1. Installation .

Step 1: Take two pieces of **A1** and two pieces of **B1 (B1-1&B1-2)** respectively, and connect them with a rubber hammer (note that it is not allowed to knock them directly, but put a board or cardboard on them and knock them in evenly).

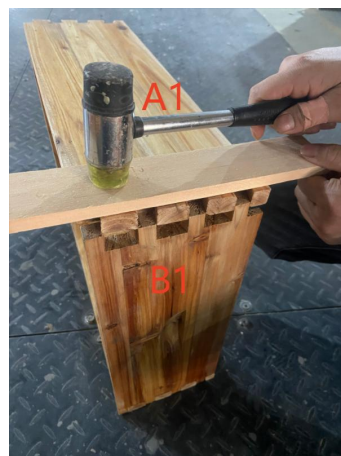
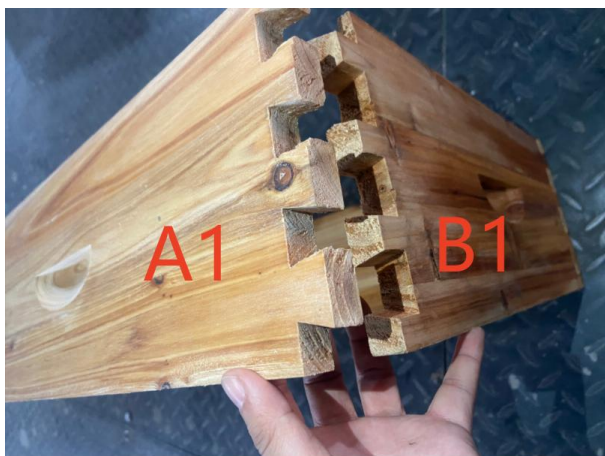

2. Installation

Step 1: Take 2 pieces of **E1** and 1 piece of **C**, insert them into the card slot to connect them, then take 1 piece of **F1** and insert it into the slot, and finally take 1 piece of **D** and insert it into the slot to complete a set.

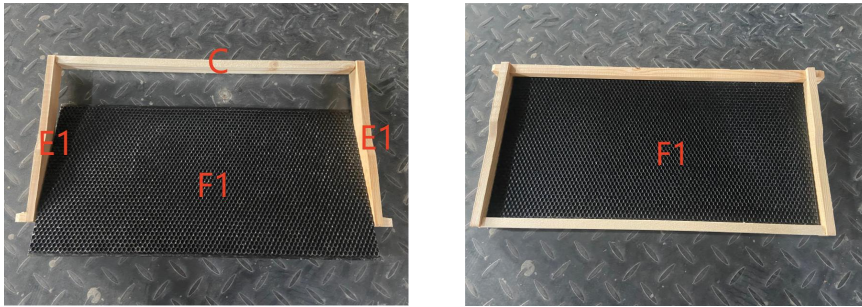

Step 2: Connect with 4 pieces of **Q** at a/b/c/d 4 positions.

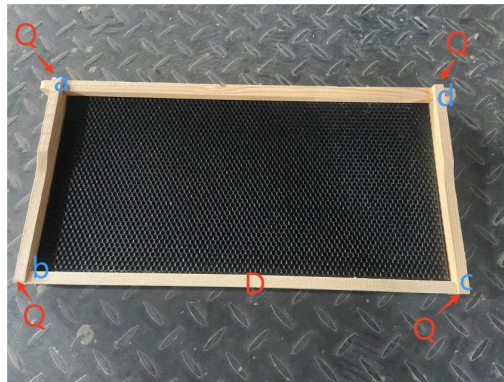

3. Installation of the Window (Window Style) (G-1D-W)

Step 1: Take **G**, **H** and **I-1** to assemble the cover plate.



Step 2: Take **S** and Peel off the film from the corners, then take **S** and **R** to assemble the Coaming.

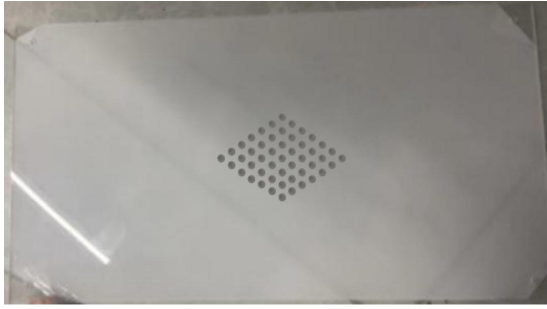

Step 3: Take **J** and **K** to assemble the window pressing plates on both sides and put 10 sets of foundations and frames into the box.



10 Frame

1. Installation

Step 1: Take two pieces of **A2** and two pieces of **B2 (B2-1&B2-2)** respectively, and connect them with a rubber hammer (note that it is not allowed to knock them directly, but put a board or cardboard on them and knock them in evenly).

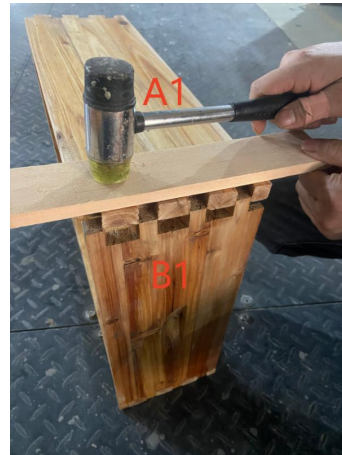
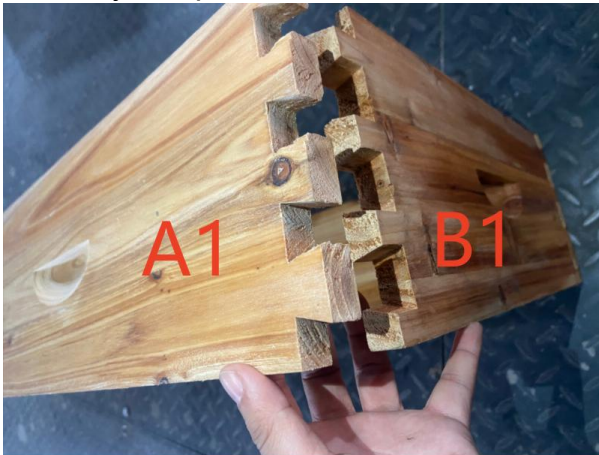

2. Installation

Step 1: Take 2 pieces of **E2** and 1 piece of **C**, insert them into the card slot to connect them, then take 1 piece of **F2** and insert it into the slot, and finally take 1 piece of **D** and insert it into the slot to complete a set.

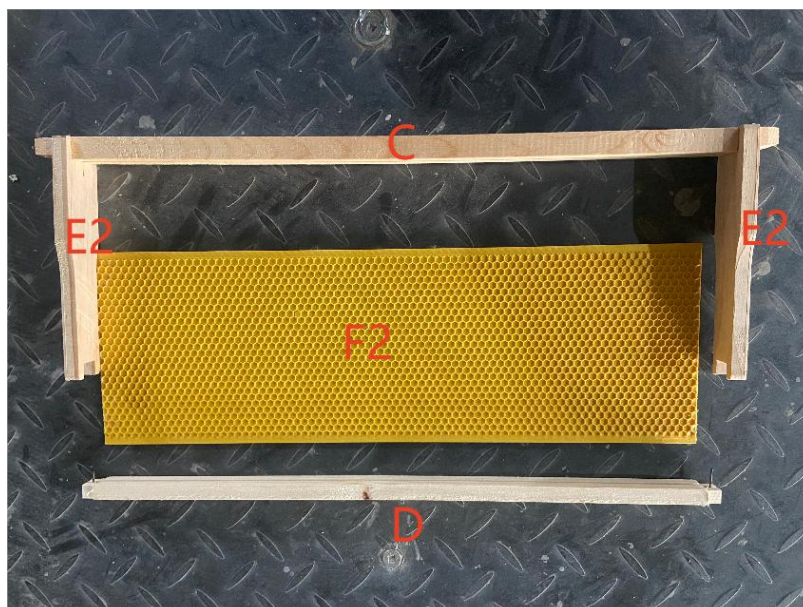

Step 2: Connect with 4 pieces of **Q** at a/b/c/d 4 positions.

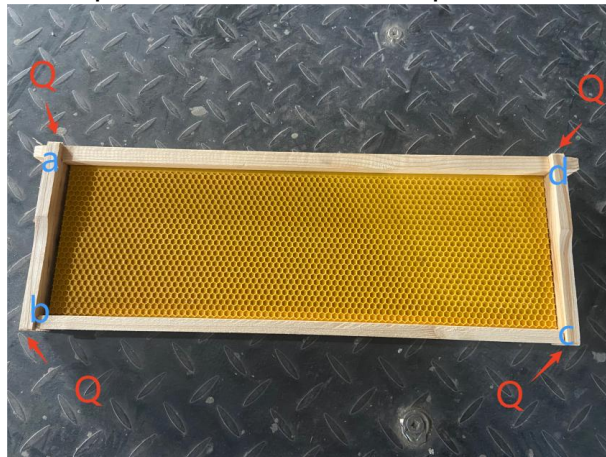

3. Installation of the Window (Window Style) (G-1M-W)

Step 1: Take **G**, **H** and **I-2** to assemble the cover plate.



Step 2: Take **N** and Peel off the film from the corners, then take **N** and **M** to assemble the Coaming.

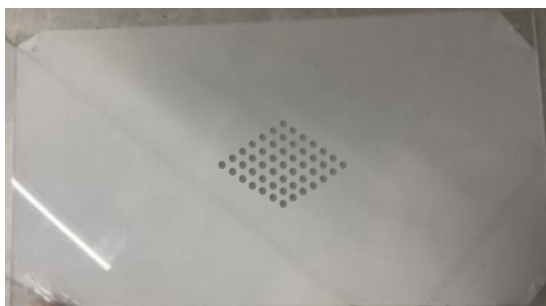

Step 3: Take **J** and **K** to assemble the window pressing plates on both sides and put 10 sets of foundations and frames into the box.



Finally, please assemble according to the following figure:

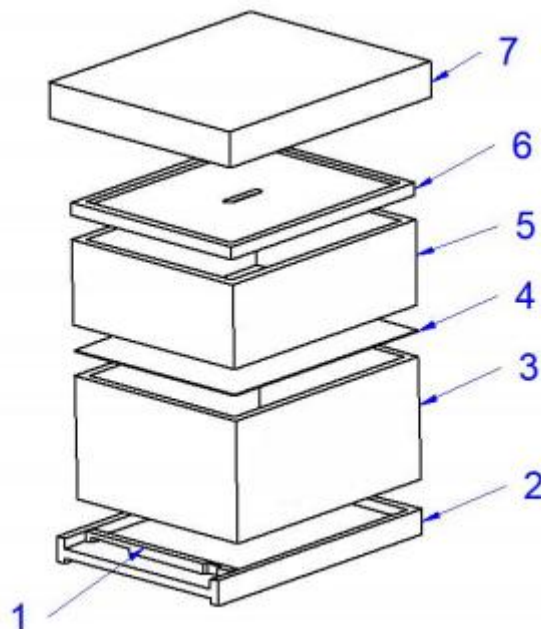

MAINTENANCE

- 1 . Please use bees wax regularly for maintenance.
2. Close the bee window in cold, rainy, and windy weather.