

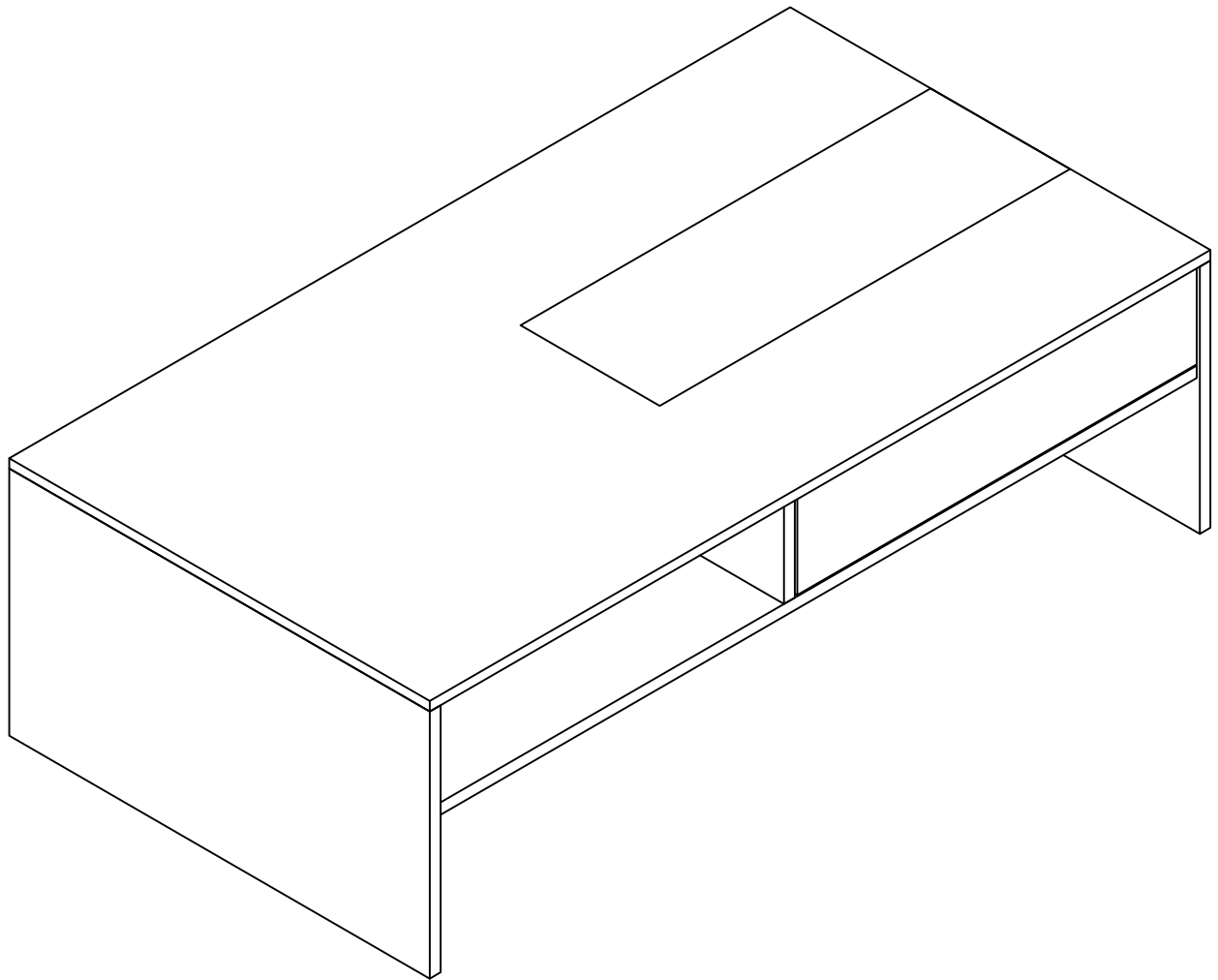

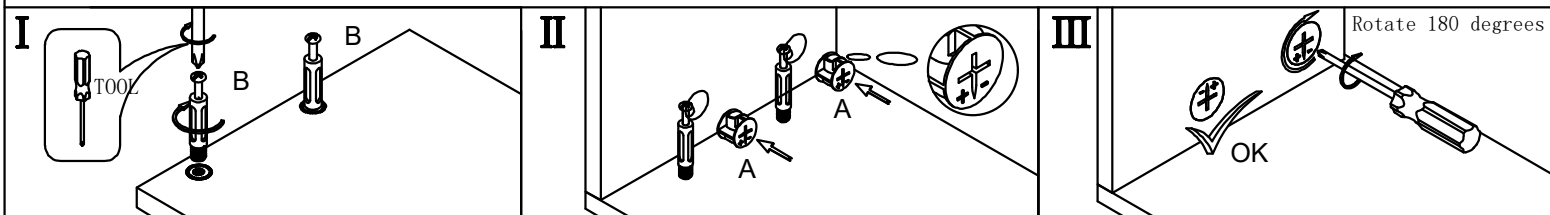







YKLCJ-001 LED Coffee Table

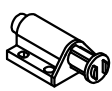
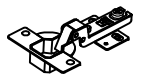

Disassembly and installation of accessories

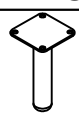

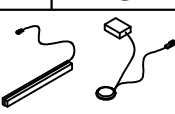
A 44PCS	B 44PCS	C 20PCS	D 28PCS	E 6PCS	F 2PCS	G 4PCS
						
Ø12*10mm	Ø6*28mm	Ø8*30mm	Ø3.5*14mm	Ø3.5*12mm		Ø35/90°
H 4PCS	I 1PCS	J 6PCS	K 1PCS			
						
Ø10*5mm	215*80*80	15*15*1mm	Lighting Kit			

Parts List

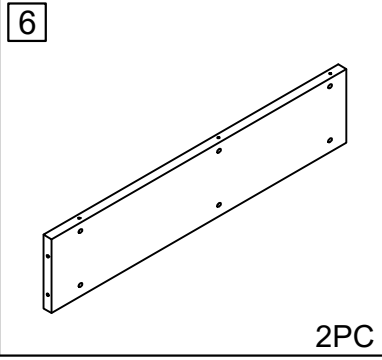
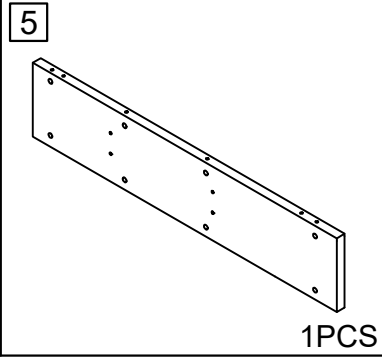
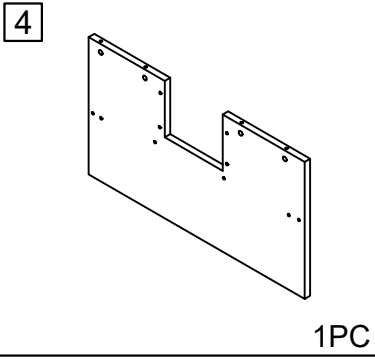
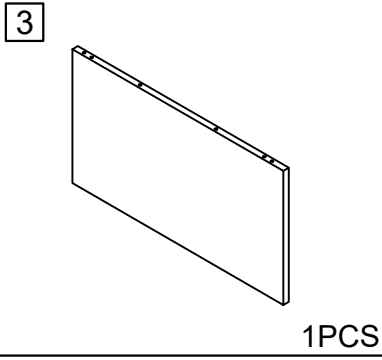
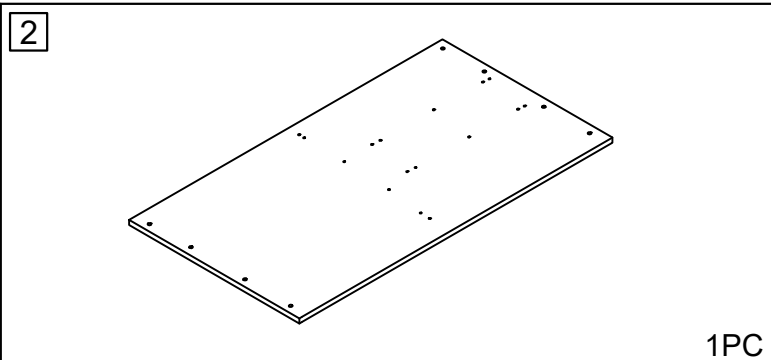
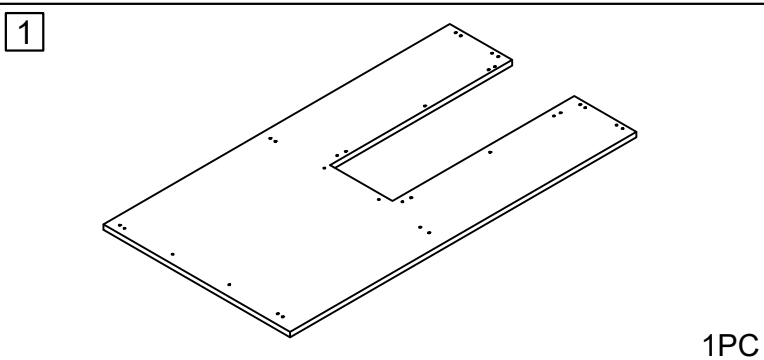
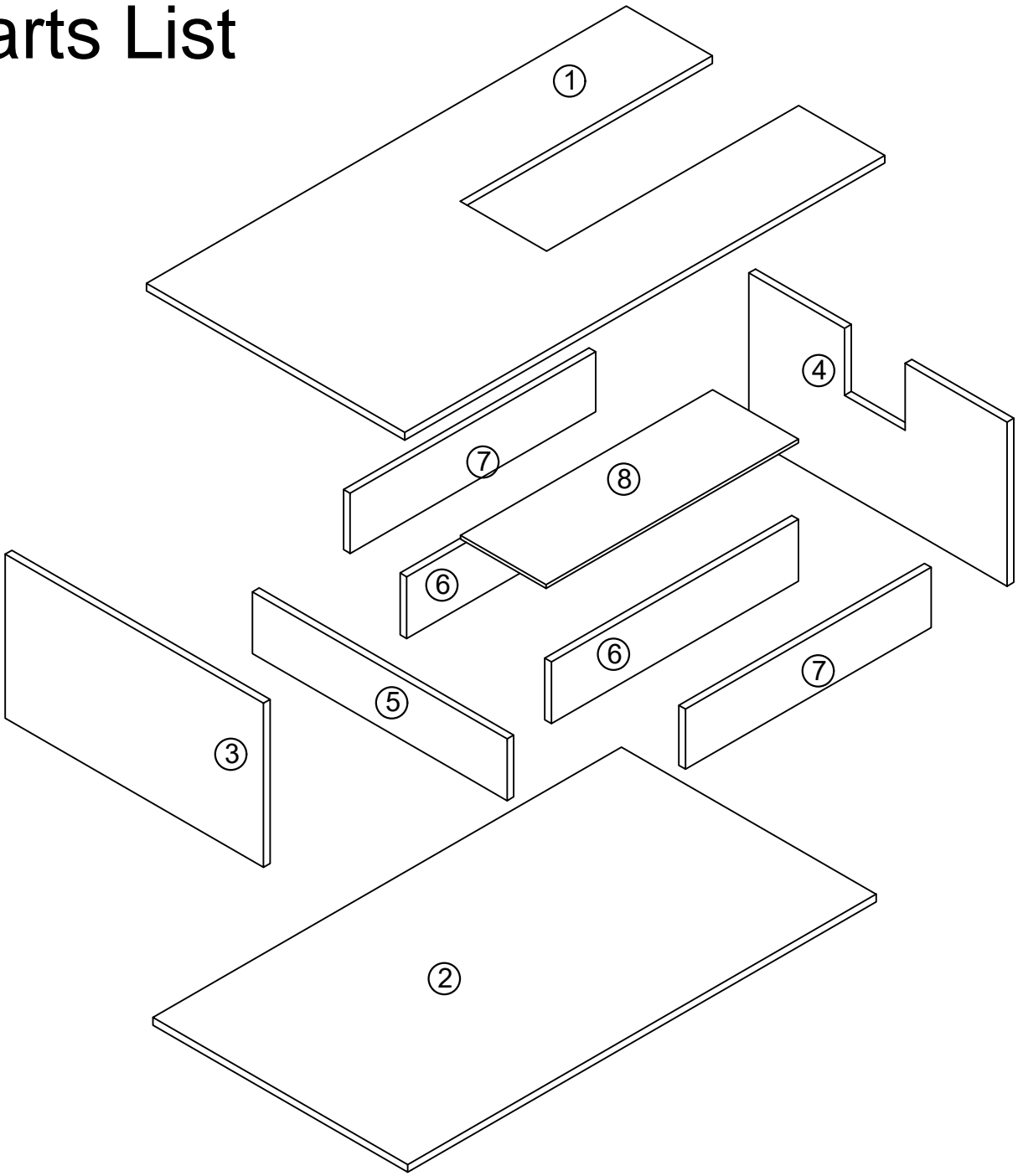

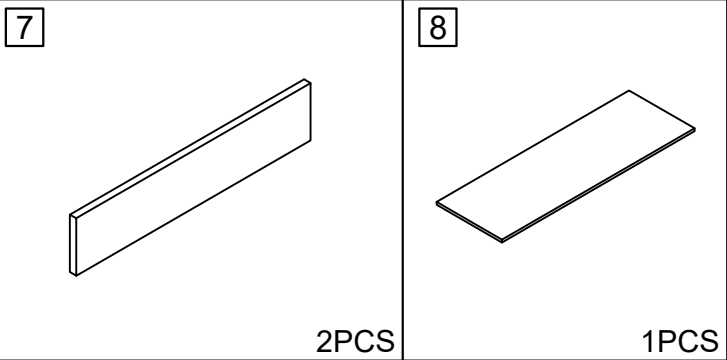

STEP 1

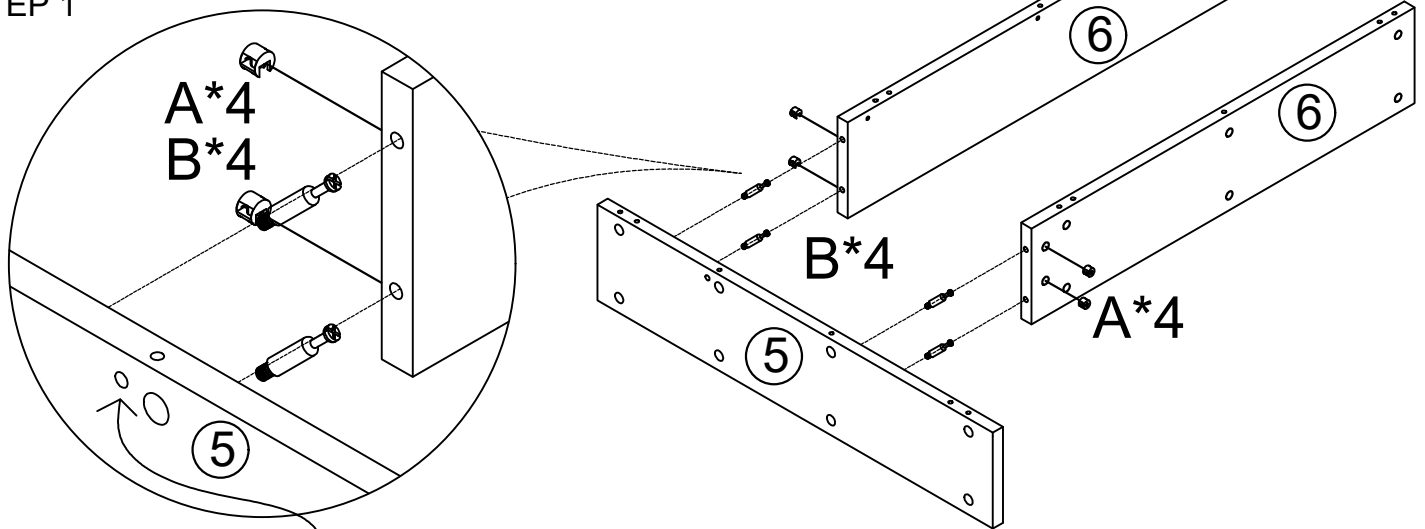

A 4PCS	B 4PCS
Φ12*10mm	Φ6*25mm

Be sure that the holes on the ⑤ board are facing upwards

STEP 2

Be sure that the holes on the ⑤ board are facing upwards

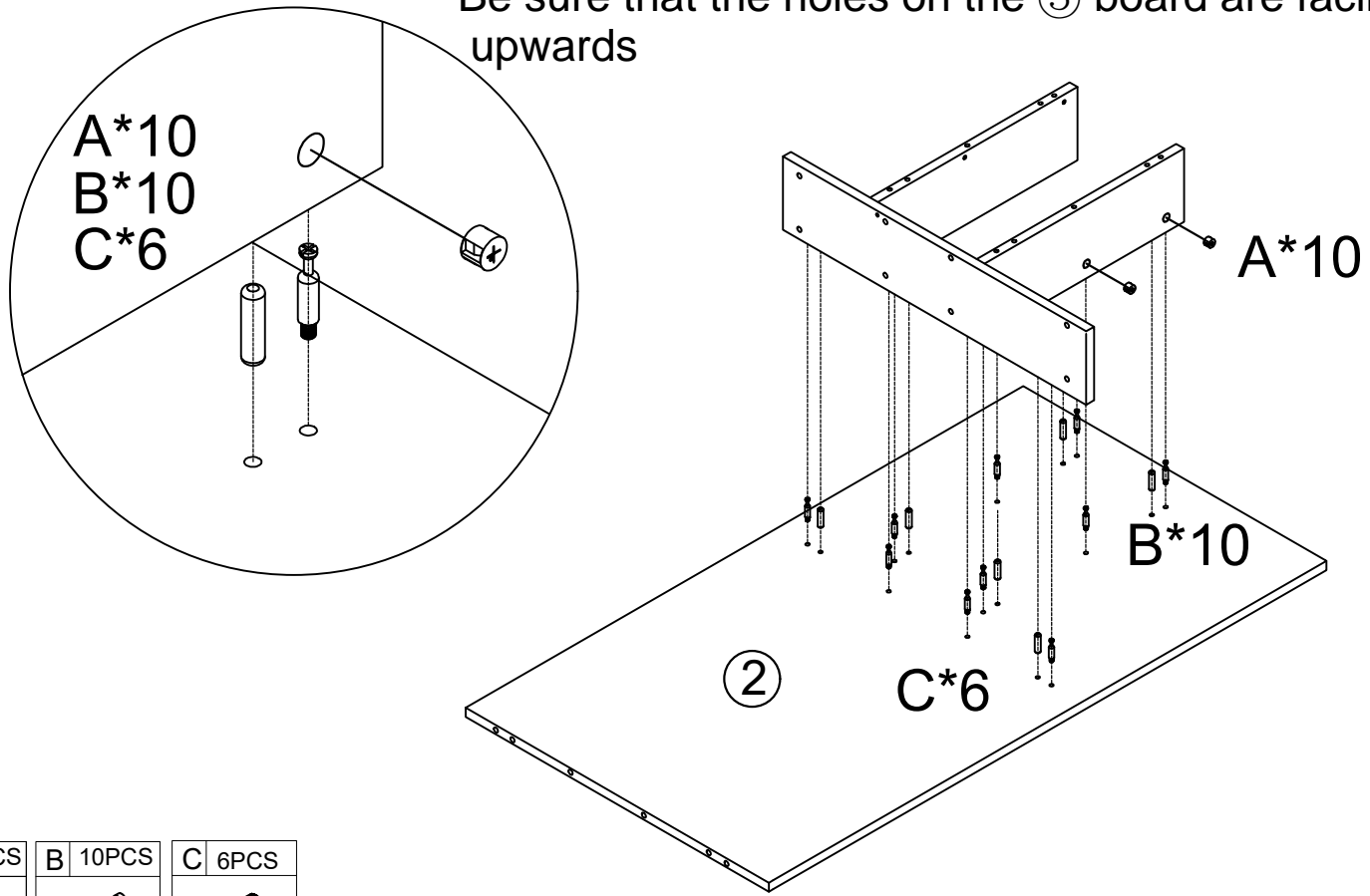

A 10PCS	B 10PCS	C 6PCS
Φ12*10mm	Φ6*25mm	Φ8*30mm

STEP 3

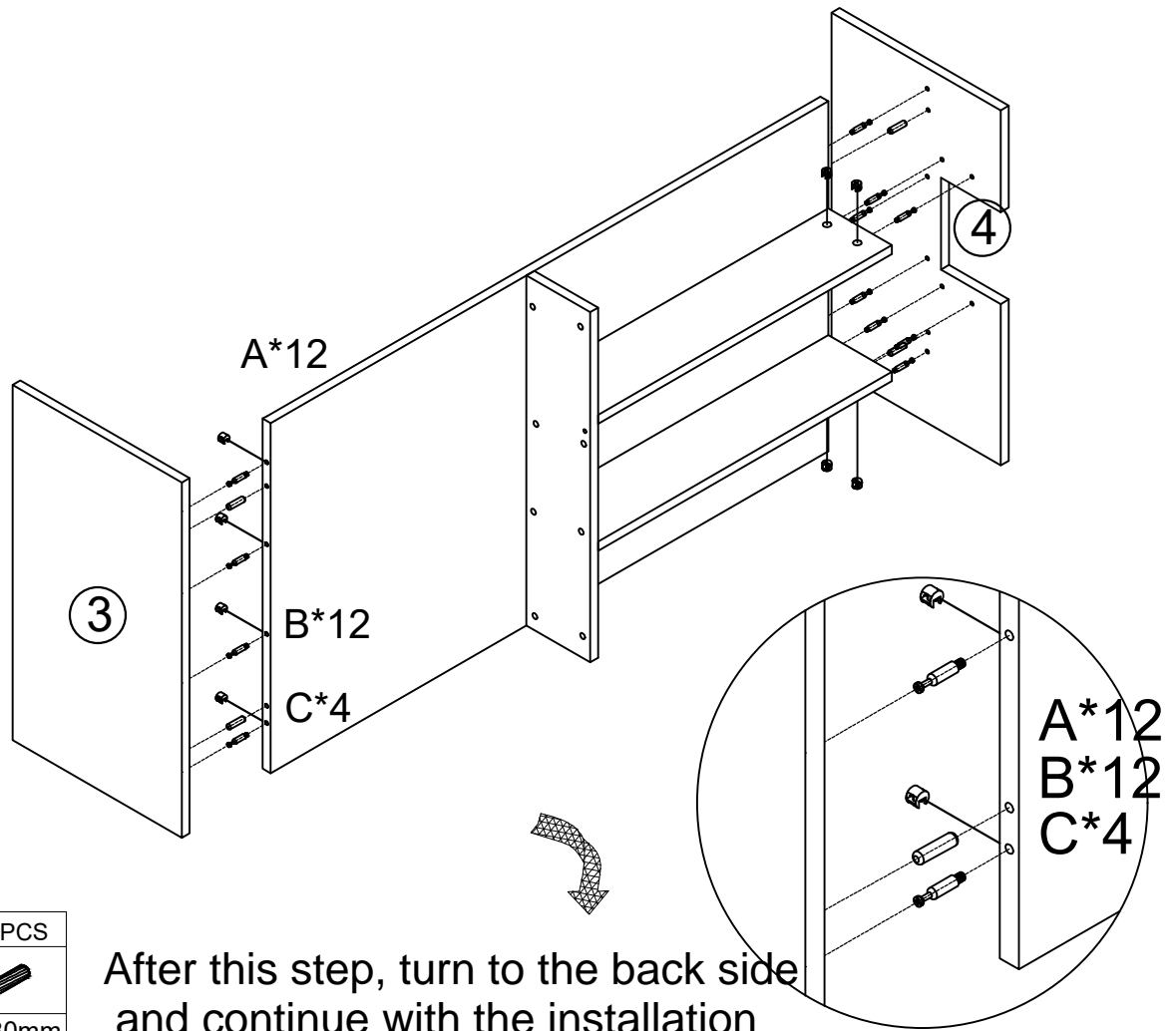

A 12PCS	B 12PCS	C 4PCS
Φ12*10mm	Φ6*25mm	Φ8*30mm

After this step, turn to the back side and continue with the installation

STEP 4

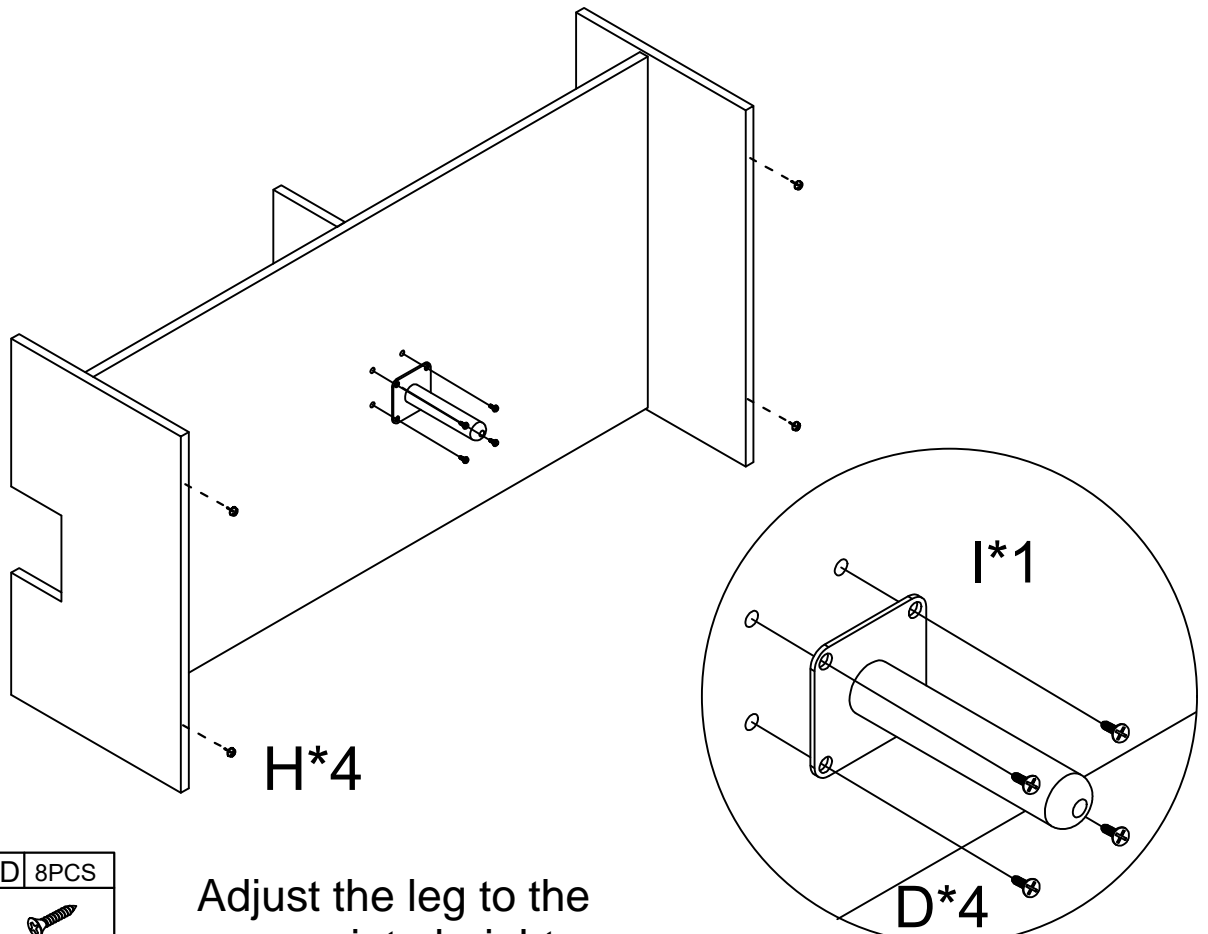

I 1PCS	H 4PCS	D 8PCS
	Φ10*5mm	M3.5x14

Adjust the leg to the appropriate height

STEP 5

Pass the light strip through the hole on the
⑤ board, then use double-sided adhesive to
stick the light strip onto the pasting area

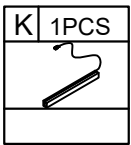
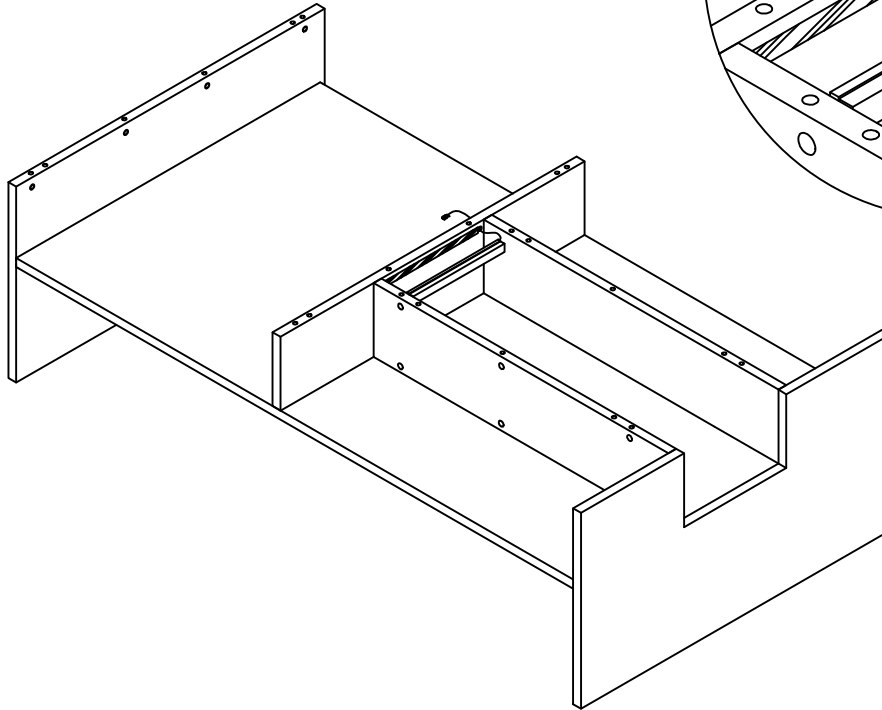

STEP 6

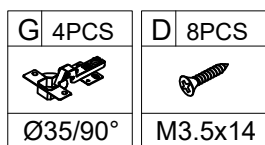
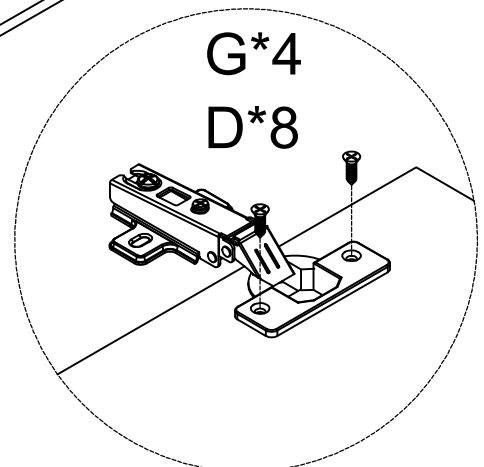
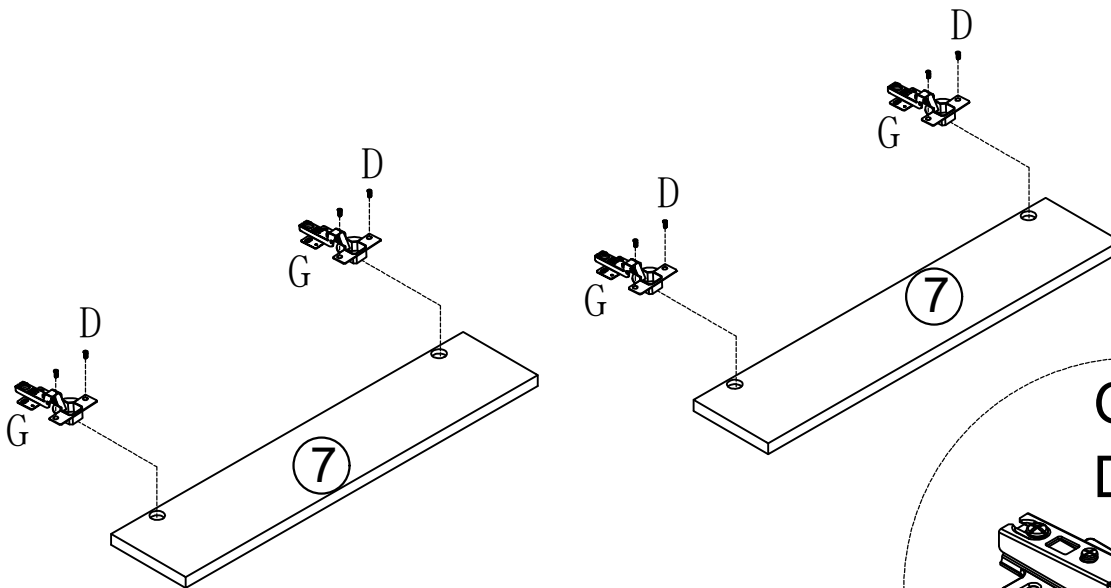

STEP 7

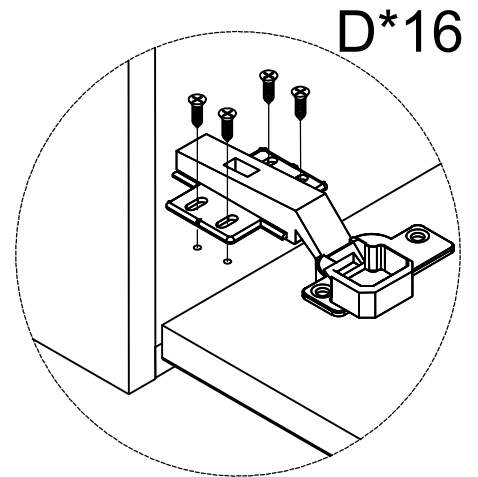
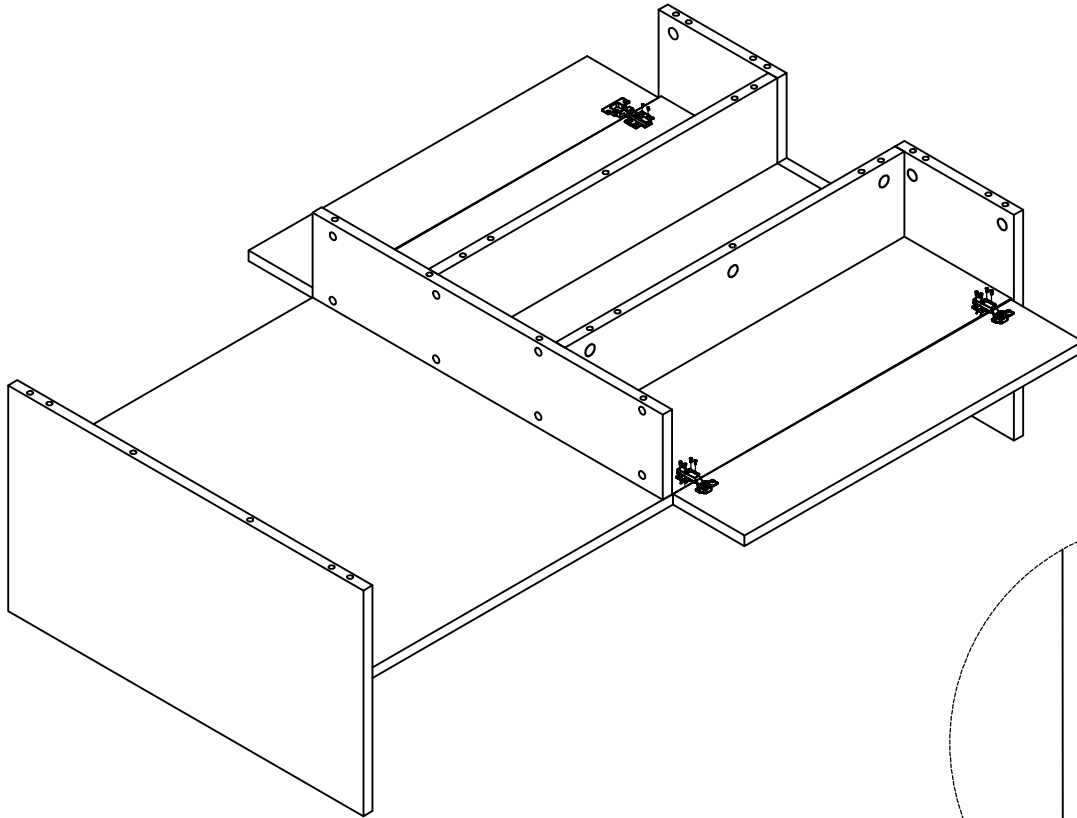



D	16PCS
	
M3.5x14	

STEP 8

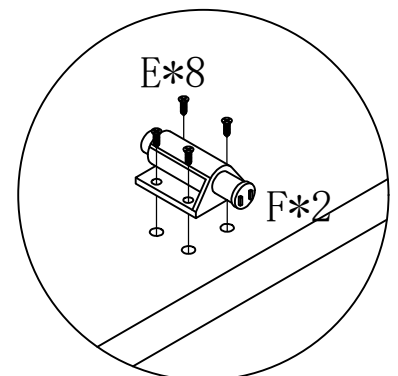
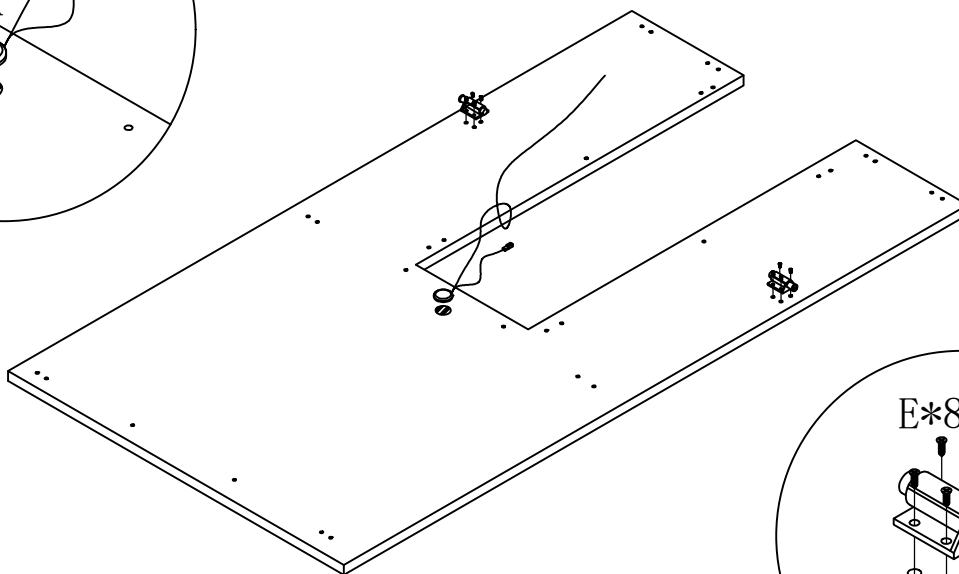
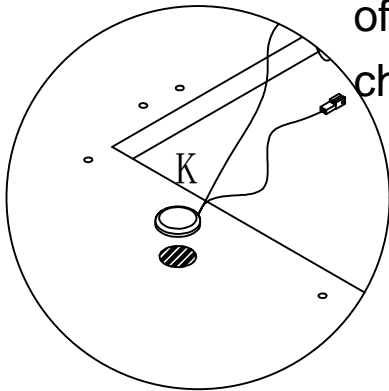
First remove the double-sided adhesive on the back of the [K] and then insert the [K] into the switch attachment area



F	2PCS	E	8PCS	K	1PCS
					
		M3.5x12			

STEP 9

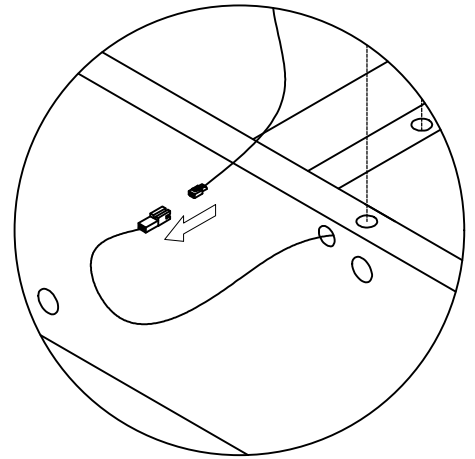
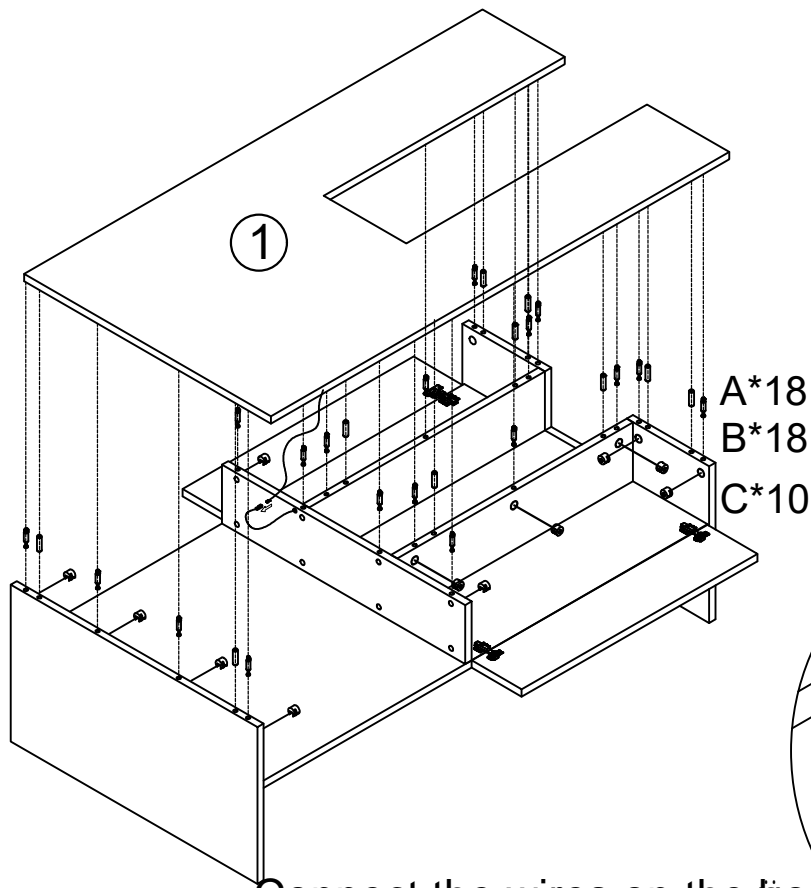

A*18
B*18
C*10

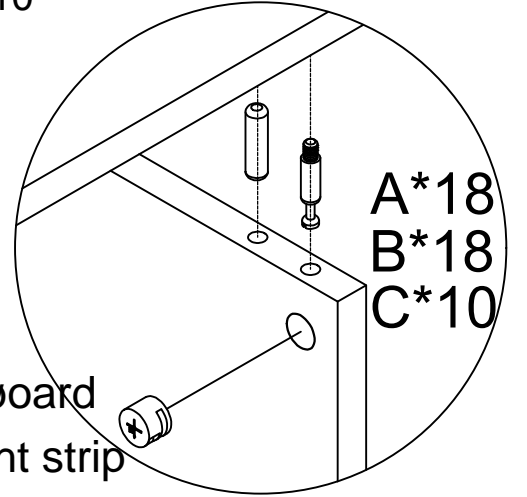

A*18
B*18
C*10

Connect the wires on the board No.1 to the wires of the light strip and then lock the hardware

A 18PCS	B 18PCS	C 10PCS
∅12*10mm	∅6*25mm	∅8*30mm

STEP 10

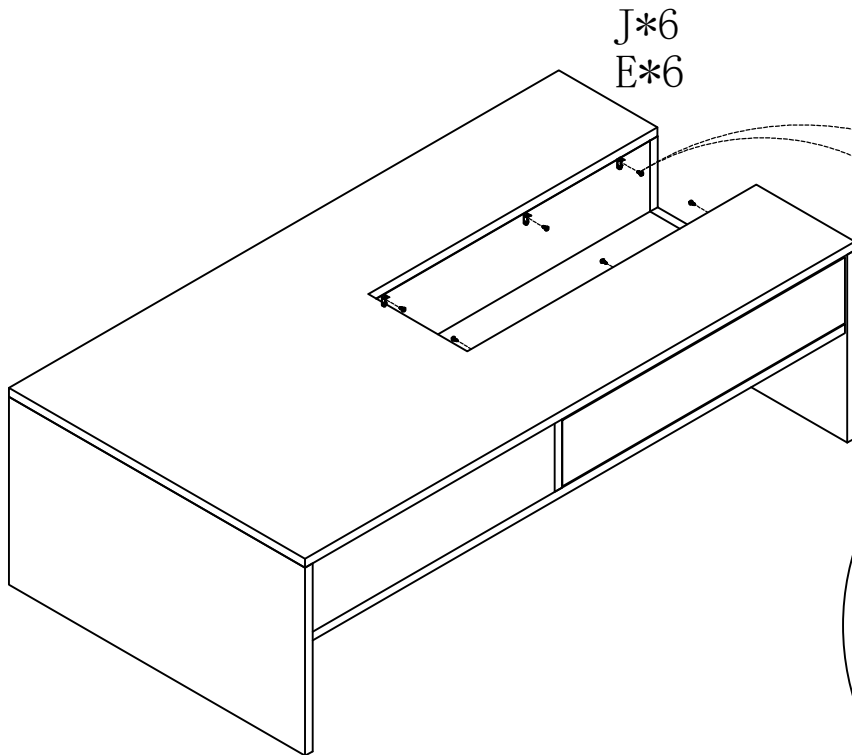

J*6
E*6

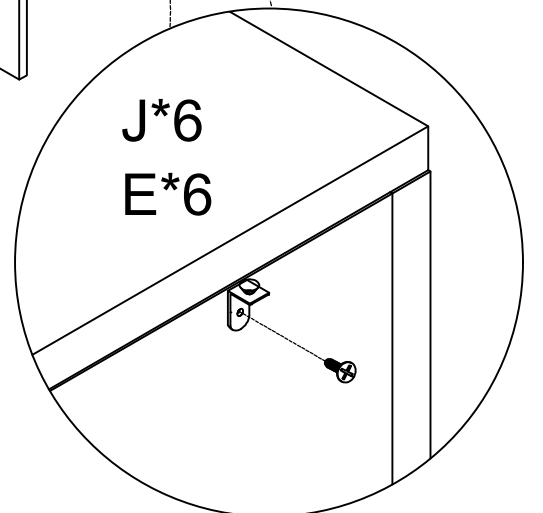

J*6
E*6

J 6PCS	E 6PCS
	M3.5x12

STEP 11

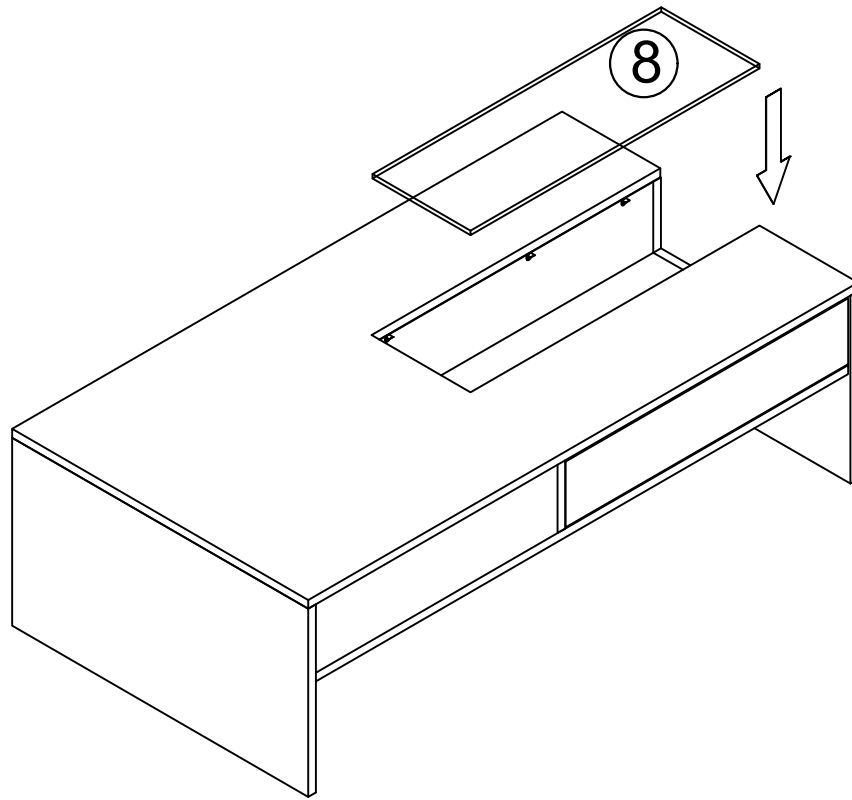

Place the ⑧ acrylic board and complete the installation

STEP 12

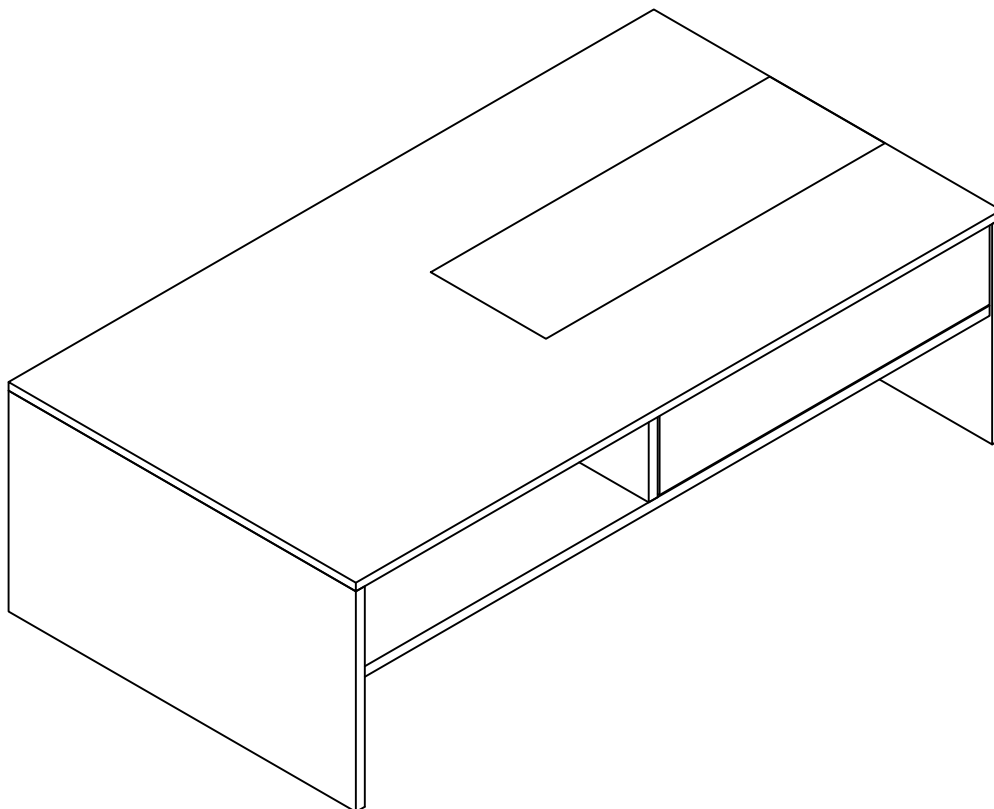

OK