

# INSTRUCTION

# ANWEISUNG

# 取扱説明書

# INSTRUCTION

VESA 610\*400mm

32"- 65"

40KG



1. Do not over tighten the screws, or it will damage the screws and decrease the holding power.
2. Before the installation is finished, do not remove or loosen any screws as it will case the TV to fall down. Using the wrench to tighten all the screws for safety after installation finished.
3. It is highly recommend to install this panel TV mount by professionals.



1. Schrauben Sie bitte die Schraube nicht zu fest, um die kaputt zu vermeiden.
2. Entfernen oder lösen Sie die Schrauben nicht, bevor die Installation abgeschlossen ist. Um der Bildschirm herunterfallen zu vermeiden. Bitte ziehen Sie alle Schrauben mit dem Schraubenschlüssel fest.
3. Es wird empfohlen, Fachmann mit der Montage zu beauftragen.

1. ネジ止めをするときは、ネジを締めすぎないでください。ネジを潰す可能性があります。
2. 組立て完了後すべてのネジをしっかり締めてください。勝手にネジを外したり緩めたりしないでください。落下によるケガや破損の原因となります。
3. 経験ある工事専門業者へ取り付け工事を依頼するようおすすめします。

1. Veuillez ne pas serrer les vis trop fort pour éviter de les casser.
2. Ne pas retirer ou desserrer les vis avant que l'installation a été finie. Sinon la télé aura une possibilité de tomber. Veuillez bien serrer toutes les vis avec la clé à la fin de l'installation pour des raisons de sécurité.
3. Il est recommandé de confier l'installation à un spécialiste.

A \*1

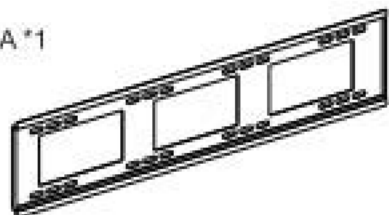

B \*1



C \*2



D \*2



E \*2



F \*2



G \*1



H \*4



M8\*55

J \*4



M8\*65

K \*8



M8\*25

L \*4



M6\*25

M \*16



Φ8\*22\*2

N \*4



O \*4



M8

P \*4



Q \*1

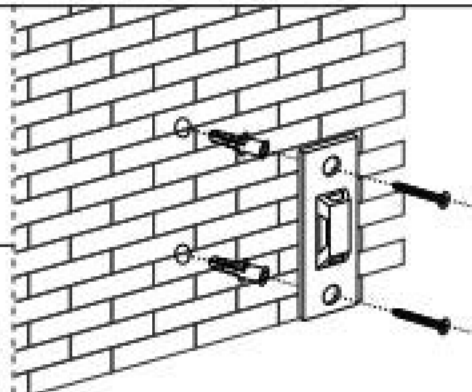
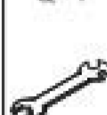

\*After finishing installation, use anti-tip over accessory G to fix the stand to wall.

\*Sie können den TV Ständer mit dem Zubehör G an der Wand befestigen, um ein Umkippen zu verhindern.

\*安全性を高めるため、転倒防止金具Gでテレビスタンドを壁に固定できます。

\*Il est recommandé de fixer le meuble TV au mur avec l'accessoire G pour l'empêcher de basculer.

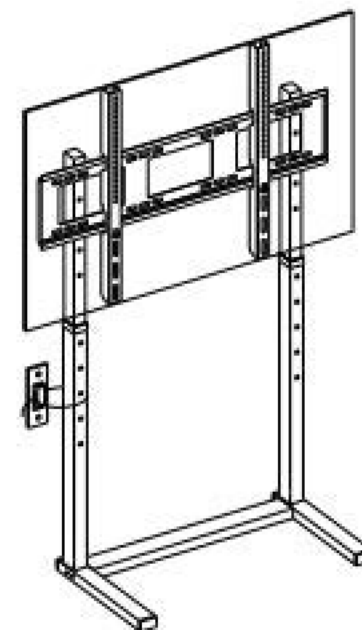

- 1** J x4 M x4

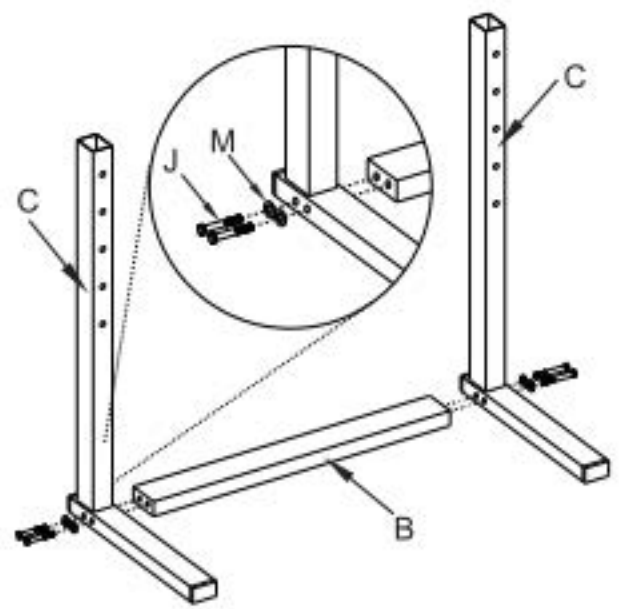

- 2** K x4 M x4

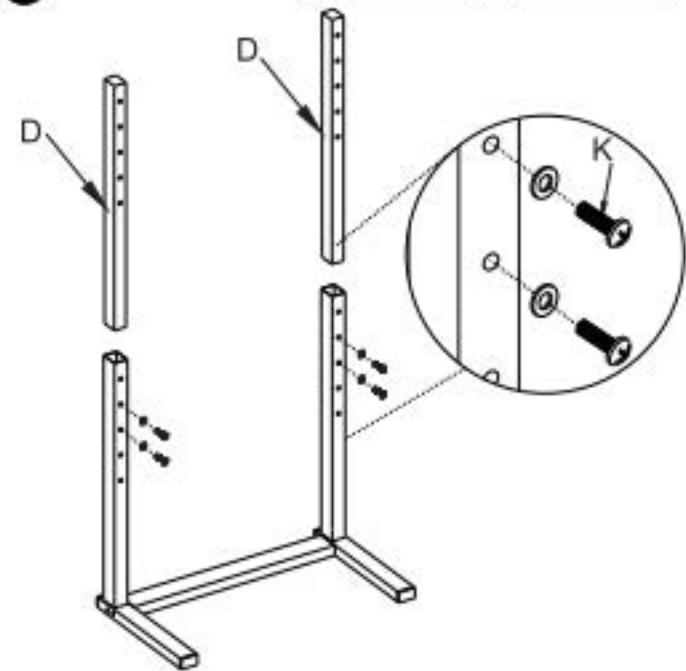

- 3** F

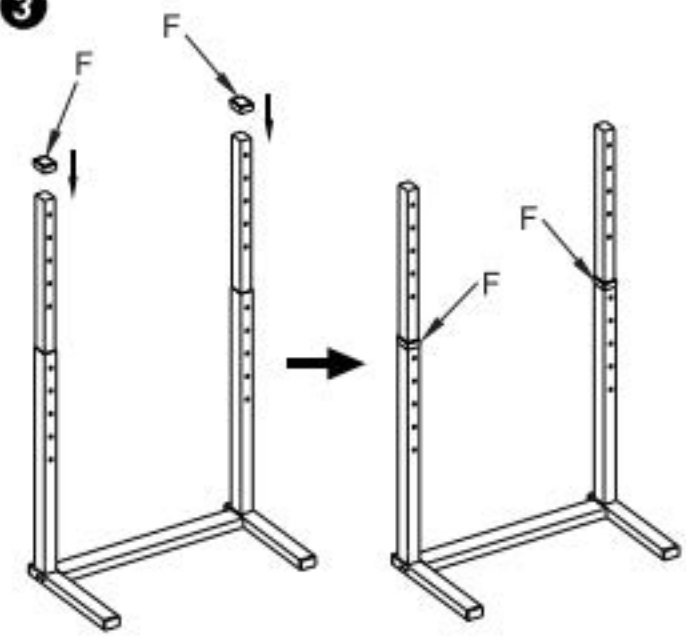

- 4** H x4 M x8 O x4

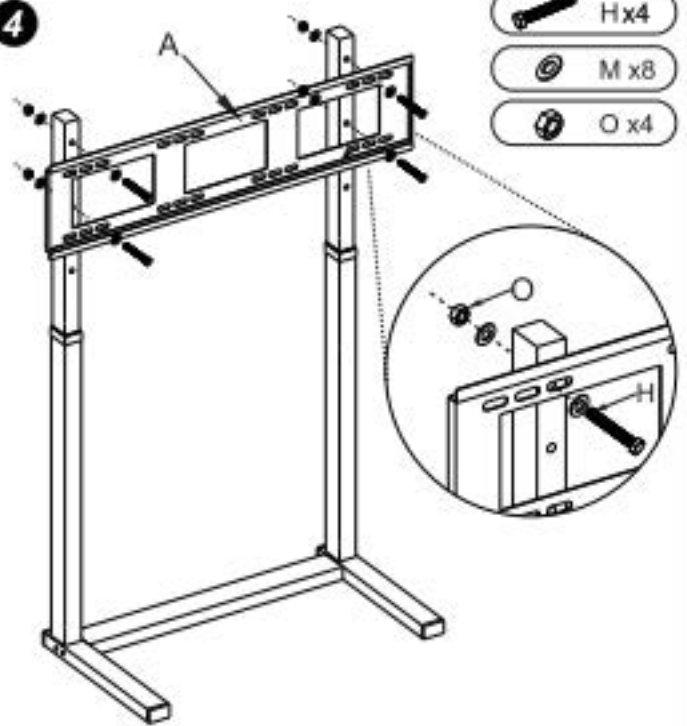

- 5** L x4 N x4 P x4

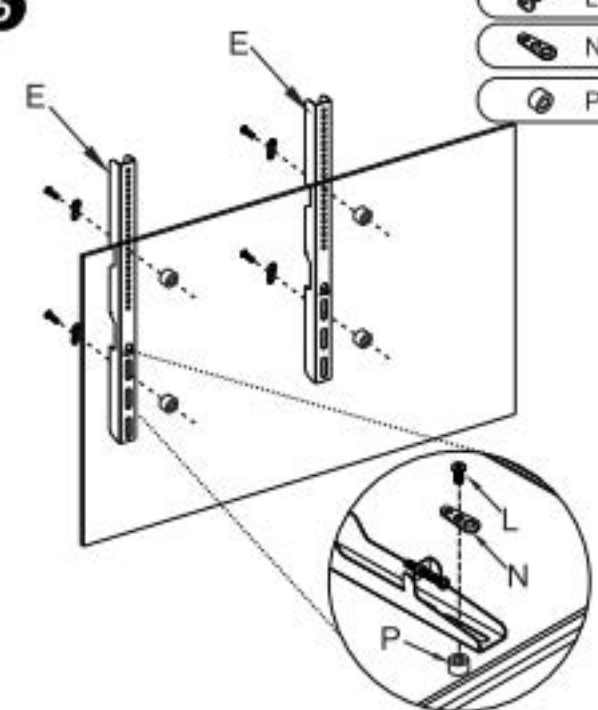

- 6**

