

ASSEMBLY INSTRUCTION

INSTRUCTIONS DE MONTAGE

SKU CODE / CODE UGS: N708P392455/N708P392456/N708P392457/N708P392458



Please refer to the tutorial video to help you with the assembly process.

Thank you!

Veillez vous référer à la vidéo tutorielle pour vous aider dans le processus d'assemblage.

Merci !

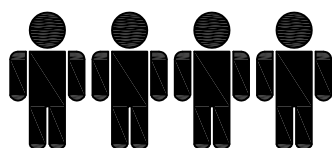
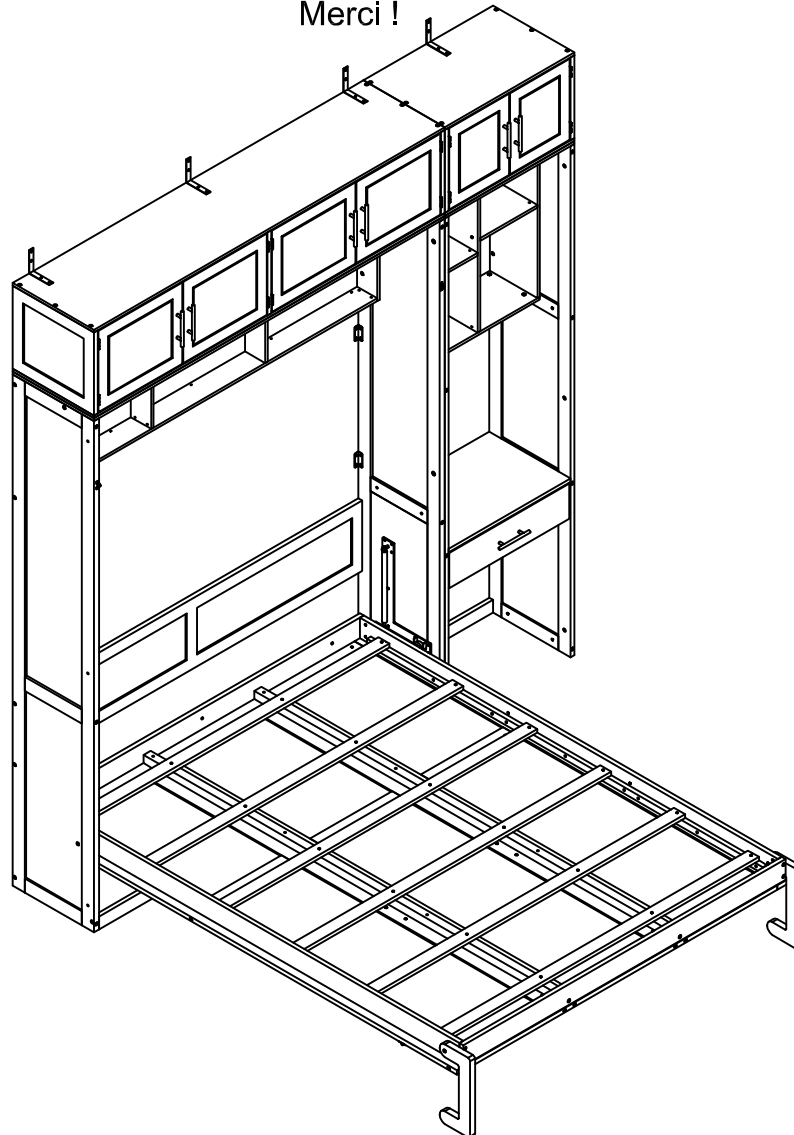

Four people are required to assemble and move this model

Quatre personnes sont nécessaires pour assembler et déplacer ce modèle

Important information to read before starting the assembly.
Keep this information for future reference.

IMPORTANT WARNINGS



Risk of serious injuries if the wall bed tips over.

To prevent wall bed from tipping over, mount it permanently to the wall.

Only a qualified person* must carry out the installation and any possible adjustment of the wall bed (including disassembly). If the wall bed is not firmly mounted (anchored) to the wall, it might tip over and cause serious injuries to the installer, users of the bed as well as the people near the bed.

The choice of wall anchoring depends on the type of wall. Use wall anchors suitable for the wall material.

*Qualified person: it is necessary to have a good understanding of the wall structure where the bed is anchored, including the positioning of the wall studs and structural components in the case of a wood or metal structure. If you do not have the necessary skills, make sure that the installation is done by someone who has the qualifications and required knowledge. When you choose the installer, make sure to comply with all applicable regulations in the province, state or country where the furniture is installed.

Informations importantes à lire avant de commencer l'assemblage.
Conservez ces informations pour référence future.

AVERTISSEMENTS IMPORTANTS



Risque de blessures graves en cas de basculement du lit escamotable.

Pour éviter tout basculement, fixez-le de manière permanente au mur.

Seule une personne qualifiée* doit effectuer l'installation et tout éventuel réglage du lit escamotable (y compris le démontage). Si le lit escamotable n'est pas solidement fixé (ancré) au mur, il risque de basculer et de provoquer de graves blessures à l'installateur, aux utilisateurs du lit ainsi qu'aux personnes à proximité.

Le choix du système de fixation dépend du type de mur. Utilisez des ancrages adaptés au matériau du mur.

*Personne qualifiée : Il est nécessaire d'avoir une bonne compréhension de la structure du mur où le lit est ancré, y compris la position des montants et des éléments structurels dans le cas d'une ossature en bois ou en métal.

Si vous ne possédez pas les compétences requises, assurez-vous que l'installation est réalisée par une personne qualifiée et possédant les connaissances nécessaires. Lors du choix de l'installateur, veillez à respecter toutes les réglementations en vigueur dans la province, l'État ou le pays où le meuble est installé.

IMPORTANT INFORMATION PACKAGE.

THIS INFORMATION PACKAGE CONTAINS WARNING AND PRODUCT SAFETY INFORMATION. DO NOT PROCEED WITHOUT REVIEWING THOROUGHLY.

A. WARNING LABELS.

Your purchased Murphy Bed is delivered to you with **WARNING LABELS** to constantly remind you to take and adopt Safety Measure throughout the entire assembly and mounting points of the Bed to the walls.

DO NOT REMOVE these labels.

These Warning Labels serve as a Reminder Tool for visiting friends and relatives when using the Murphy Bed to ensure Safety Precautions are taken.



WARNING.

IMPORTANT SAFETY REQUIREMENTS - Bed Attachment to Wall. For Your Safety, the Murphy bed MUST BE ATTACHED to the Wall.

Seek Certified Professional Consultant / Contractors for their Services to:

- 1.) DETERMINE the WALL Type in Your Home;
- 2.) PRECISE HARDWARE that suits to the Wall Type in Your Home;
- 3.) INSTALL / ATTACH of the Murphy Bed to the Wall in Your home;
- 4.) VALIDATE the Murphy Bed is appropriately and securely installed/attached.

The choice of wall anchoring hardware depends on the type of wall. This Murphy Bed is delivered with **HARDWARE SCREWS** suited for attachment to **WOOD STUDS** in walls. Any **STUDS** type detected with your Consultant-Contractors to be **NOT WOOD STUDS** - **DISCARD** and **DO NOT USE** these **SCREWS**. Use the hardware suitable for your wall material.

Seek the professional advice of your Consultant-Contractor and procure the appropriate hardware and brackets for the attachment of the Murphy Bed to the Wall.

FAILURE TO ADHERE TO THE ABOVE INSTRUCTIONS MAY RESULT IN SERIOUS and/or SEVERE INJURIES or Death caused by the detachment of the Murphy Bed from the Wall.

SAFETY PRECAUTION :

1.) **MAXIMUM** Mattress Weight suited to your Murphy Bed: 77 lbs (35 kg);
MAXIMUM mattress thickness: 6-8inches (15.2 – 20.3cm);
2.) **ENSURE ADULTS ONLY** throughout the entire assembly and attachment
3.) **KEEP ALL Children, Non-Ambulatory persons and Pets** at bay during the entire assembly and attachment

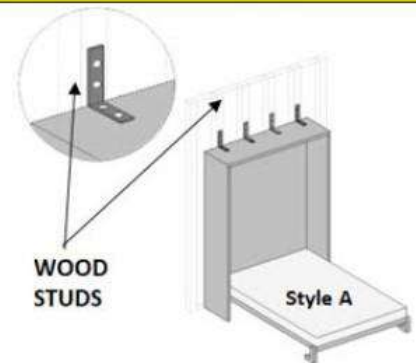

WOOD STUDS

Style A

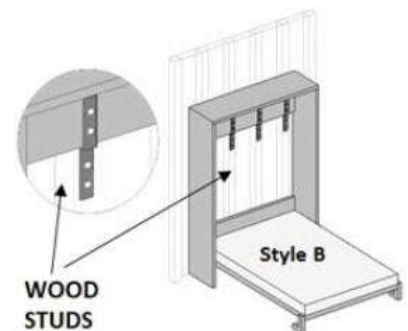

WOOD STUDS

Style B

LINE ART for Reference only and NOT DRAWN TO SCALE.

MATTRESS PLACEMENT.

Only after the Murphy Bed is **FULLY SECURED** to the wall, the 2 adult persons who are holding down the entire Murphy Bed, can now be released for this action. Have 1 to 2 persons - place equal strengths to the handles and gently and securely, **PULL DOWN** the Bed Frame until the Bed Frame is horizontally and level to the ground. Have the other 2 persons - carry and place the Mattress (**within the recommended weight and thickness**) and gently place the Mattress on to the Bed Frame.

CAUTION : Homes are renovated differently. There are CONCRETE walls and "hollow walls". Hollow walls are reinforced with STUDS of Wooden or Steel Materials. Seek advice from professionals.

Style A - VERTICAL Murphy Bed with SEALED/CLOSED Back board.

Style B - VERTICAL Murphy Bed with OPEN STYLE Back board.

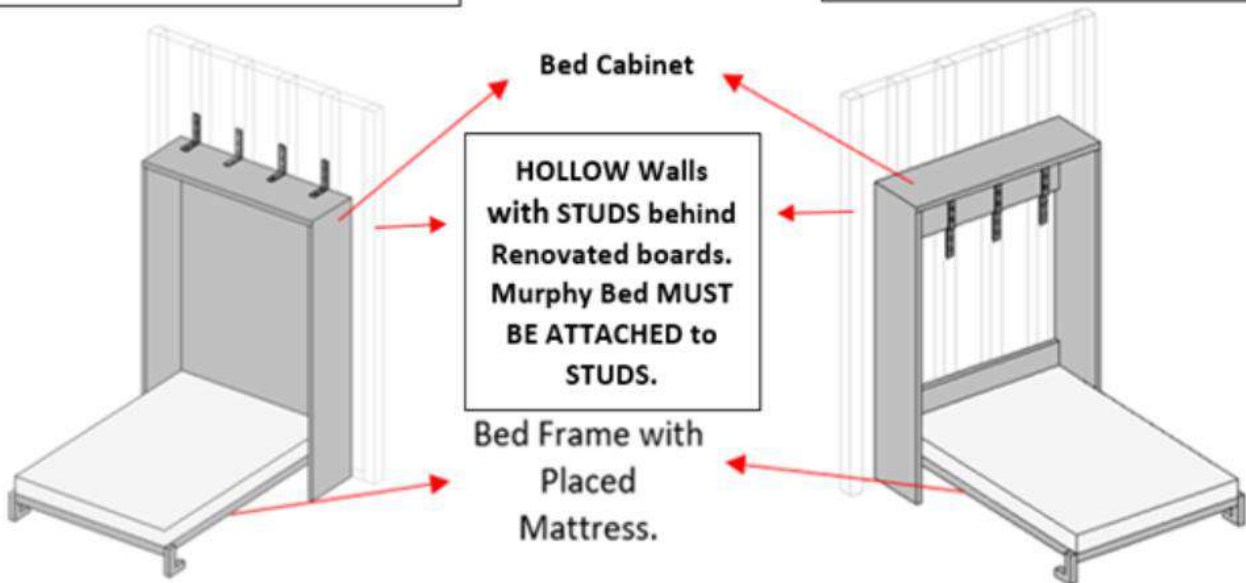

B.) SAFETY REMINDERS.

MARKINGS in WALL – WHERE TO ATTACH the MURPHY BED.

Irrespective of the wall type, whether **Solid Concrete Walls OR Decorative Walls with WOODEN Studs OR Decorative Walls with Metal Studs**, ensure that

-) you choose a professional installer who has a good understanding of the wall structure where the Murphy Bed is anchored, including the position of the wall studs and structural components in the case of a wood or metal structure.**
-) precise markings of the positions of the anchor points are to be made on the wall for easy identification during the Murphy Bed attachment to the wall.**
-) the relevant and appropriate Hardware with Metal Brackets are READY for this attachment and are within easy access for prompt and efficient attachment.**

This product requires Professional Consultation and Installation*.

* When you choose the professional installer, make sure to comply with all applicable laws, regulations and rules in the city, state or country where the Murphy Bed is installed.

To have your Murphy Bed fully assembled and to achieve its intended functionality – you **MUST READ** through this entire Assembly Instructions Manual before you start the assembly of the bed

- 1.) **There are numerous Safety Issues and Safety Precautionary Actions that you MUST KNOW before you start the Assembly.**
- 2.) **CAUTION - Failure to FOLLOW / ADHERE to the GUIDE, WARNING AND REMINDERS here, may result in serious / severe injuries or death.**
- 3.) **PRECAUTION : For the assembly, Adult Partners only, to assist in the entire assembly. Ensure 4 (four) to 6 (six) ABLE BODIED PERSONS ONLY in the entire assembly and attachment of this Murphy Bed to the walls of your home.**
- 4.) **CAUTION : During the entire assembly process and attachment of the Murphy Bed to the walls of your home, Keep ALL Children, Non-Ambulatory Persons and Pets completely at bay.**
- 5.) **SAFETY REMINDER on / to : Personal, Family Members and Pets.** The Murphy Bed may be shipped to you in 3 to 5 packages and are **HEAVY**. Each carton holds many parts and components. Some of these components eg., bolts and screws are relatively small* in size.

* . During the assembly process, ensure that any misplaced bolts and nuts are picked up so that Children and or Pets do not play or ingest these.
- 6.) **This Murphy Bed is intended for ADULT USE ONLY.**
- 7.) This Murphy Bed is delivered to you pre-packed with Hardware - **suitable for wood-framed walls renovated with WOOD STUDS ONLY.**
- 8.) **Your Home's Wall Type** - Every home is renovated differently with different wall(s) type / finishes. Before you proceed to assemble your Murphy Bed :
 - a.) **SEEK and CONSULT Professional Services** to ascertain the wall type in the designated location where you intend to attach the Murphy Bed;
 - b.) **ENSURE** the Consultant-Contractor specifically **INFORMS** you of the **WALL TYPE** in the designated spot where you intend to attach the Murphy Bed.
 - c.) **ENSURE** the Consultant **INFORMS** you specifically on the matching and relevant Hardware / Brackets to secure and attach the Murphy Bed to the wall.
- 9.) **WARNING – YOU MUST HEED THE INSTRUCTIONS** given by your appointed Consultant-Contractor on the :
 - a.) Mounting Hardware Type that suits the wall(s) type - where / when it is NOT WOOD STUDS, the **pre-packed Screws for Wood Stud Walls would not match/ not fit.**
 - b.) Number of Mounting Points for the Murphy Bed to the Wall.

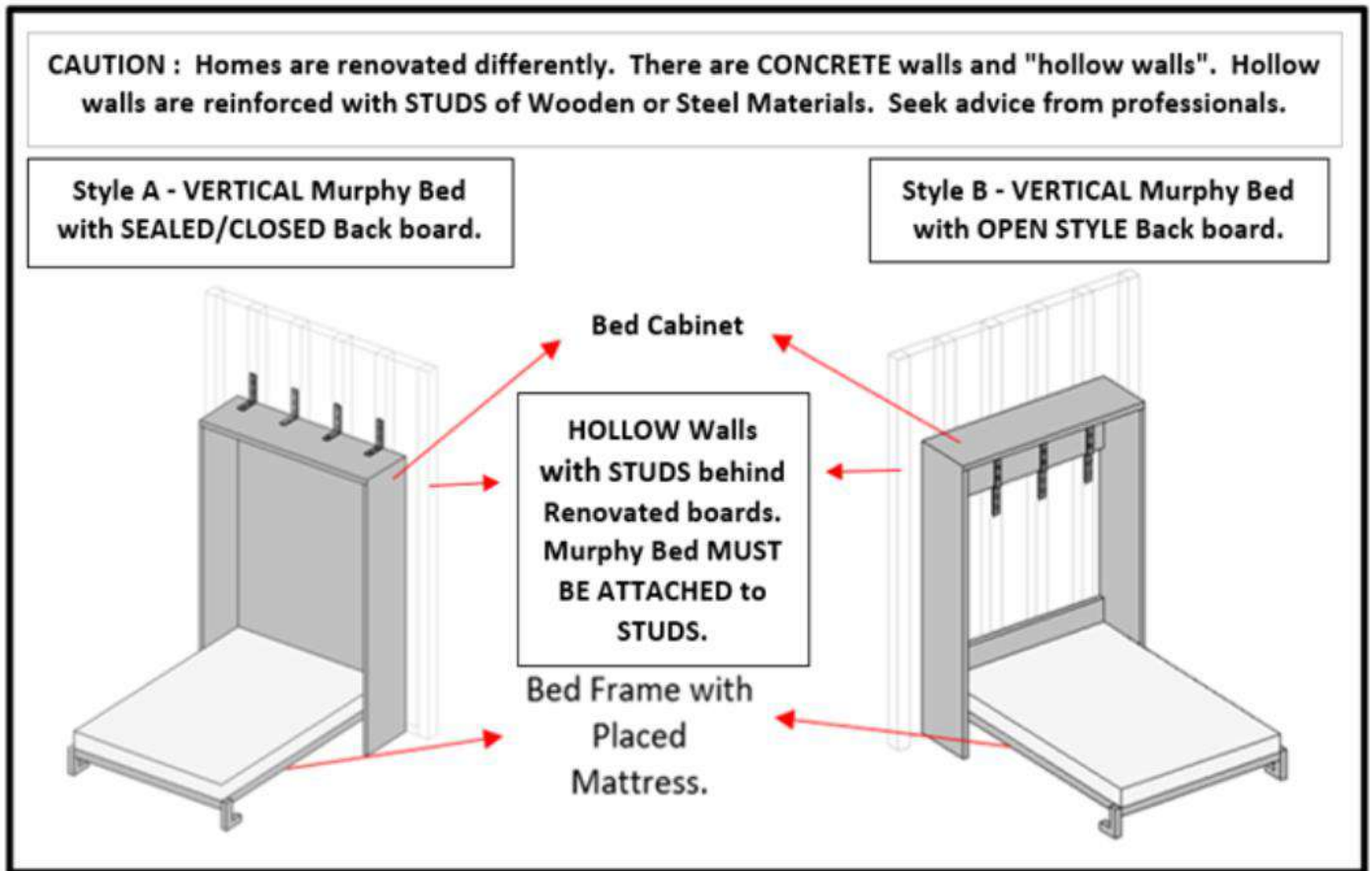

10.) This Murphy Bed is designed for home use and not intended for commercial use.

11.) This Murphy Bed is not intended to be moved, modified, uninstalled or disassembled once professionally installed.

C.) MOUNTING INFO & HARDWARE.

1.) **REMINDERS :**

- a.) In the event, that this pre-packed Screws Set does not match to the walls in your home – **DO NOT USE / DISCARD these hardware.**
- b.) **ADHERE to the Professional Consultant-Contractor** instructions and information on the **RELEVANT** mounting hardware that suits your wall.
- c.) Procurement of these **RELEVANT** hardware is an arrangement made between your Consultant-Contractor and you.

2.) A step ladder (not provided) is needed to attach the L-Brackets to the wall, at the Top of the Murphy Bed. **DO NOT** lean against the Top of the Murphy Bed, it may cause sagging.

Murphy Bed Style A

L-Bracket Fixture to Wood Studs

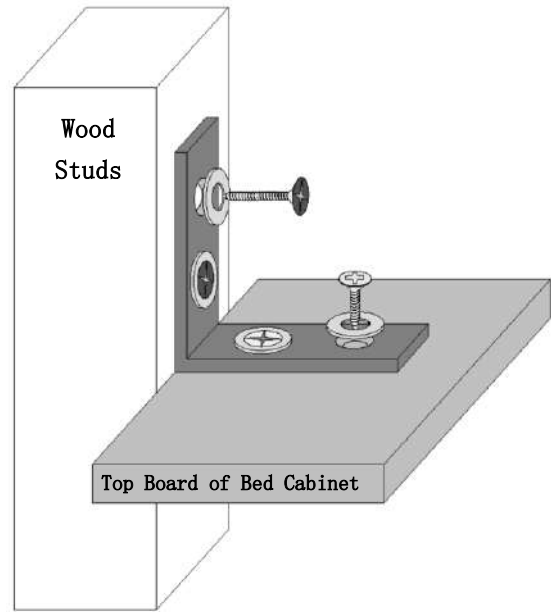
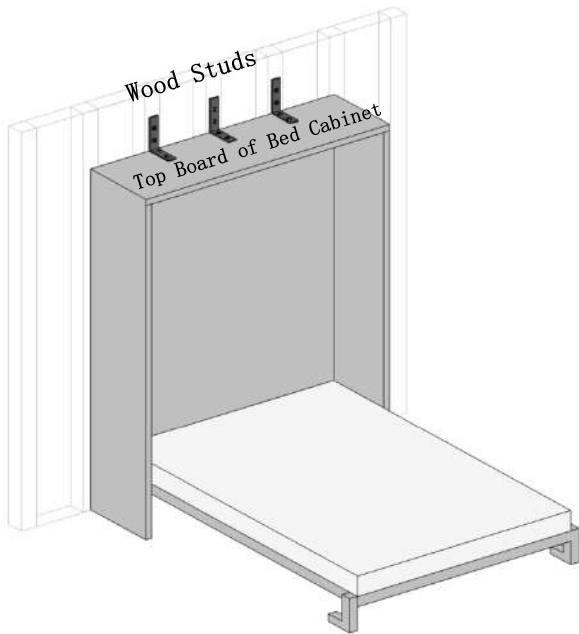

Z-Bracket Fixture to Wood Studs

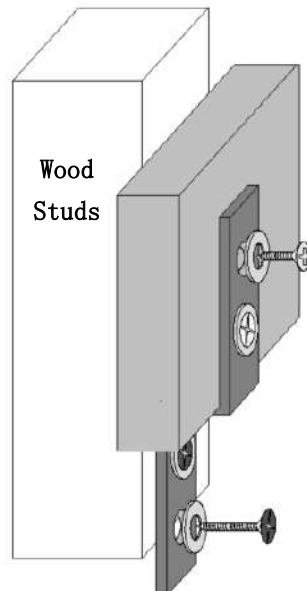
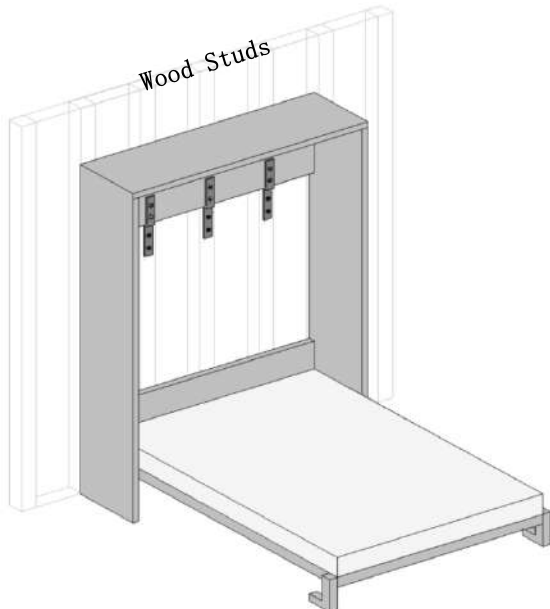

D.) IDENTIFICATION of TOOLS and ATTACHMENT SKILL.

The parts and components to assemble the Bed Frame are stated in the Assembly Instructions. Follow the instructions with attention.

For an efficient assembly, after opening the cartons shipped to you :

- a.) open and layout all parts and components in sequence;
- b.) account for every part, hardware and component;
- c.) then lay out the parts close to each other;

Assemble and tighten each bolt / nut / screw up to 80% to allow for the Bed Frame and Bed Cabinet to be HELD together.

Upon FINAL assembly where all the parts and components are FITTED precisely, in a sequential manner – proceed to tighten each bolt & nut & screw gradually.

CAUTION :

- 1.) **The METAL PLATES to the sides of the Side Rails – MUST BE FULLY and SECURELY TIED to the SIDE RAILS.**
- 2.) **The Piston L-Brackets that are attached to the INNER WALL of the Bed Cabinet – MUST BE FULLY and SECURELY TIED to these Inner Walls.**
- 3.) **These Metal Plates and the L-Brackets – are the components that are holding the Pistons that allow your Bed to “travel” to an OPEN or CLOSED position.**
- 4.) **Frequent Inspections of these Metal Plates / Brackets and Pistons Bolts, up to Once a Month – to ascertain these DO NOT BECOME LOOSE. For if these bolts to the Bed Frame and or Bed Cabinet or Pistons are loose, may cause the BED FRAME to become DISLODGED and cause injuries.**

REMINDER : NEVER FULLY TIGHTEN any screw / nut or bolt in one session. If you DO TIGHTEN the hardware all the way into the core of the wood, this cause the parts to become skewed that would impact other parts of the item not being able to be aligned to its mounting points for assembly.

E. ALL ASSEMBLY WORKS REQUIRES A TEAM OF NO LESS THAN 4 ADULTS.

Reminder : Per above info, the cartons and products are heavy – therefore exercise CAUTION at all times and ENSURE YOUR TEAM OF 4 for the entire ASSEMBLY.

F.) ASSEMBLY of BED FRAME.

Identify all parts and components for the Bed Frame.
Assemble the Bed Frame according to the Assembly Instructions.

Upon completion of assembly of the Bed Frame, make a final inspection that all joints and parts are fully and securely attached.

Then, place the fully assembled Bed Frame flat on the ground, approximately 10 feet away from the Bed Cabinet installation area, to allow enough space for assembling the Bed Cabinet.

G.) ASSEMBLY OF BED CABINET.

Identify all parts and components for the Bed Cabinet.
Assemble the Bed Cabinet according to the Assembly Instructions.

Upon the completion assembly of the Bed Cabinet, make a final inspection that all joints and parts are fully and securely attached.

CLEAR all debris in the area where your Murphy Bed is going to be attached to the wall.

Move this FULLY ASSEMBLED BED CABINET and position this BED CABINET some 2 feet to 3 feet away from the designated Wall, where you have previously made markings.

SAFETY REMINDER – The Cabinet is NOT ATTACHED TO THE WALL, YET. From here on - YOU MUST HAVE 2 ADULT to HOLD and STABILISE this BED CABINET, to prevent the Bed Cabinet from TIPPING OVER.

H. ATTACHMENT OF BED FRAME TO BED CABINET.

Safety Reminder : DO ENSURE the 2 adult persons holding the Bed Cabinet is IN POSITION ALL THE TIME.

The other 2 adults shall lift and carry the Bed Frame and attach to the L-Bracket – at the inner walls of the Bed Cabinet.

Thereafter, gently LIFT THE Bed Frame to a CLOSED POSITION.

I.) ATTACHMENT OF PISTONS TO HOLD & SUPPORT BED CABINET TO BED FRAME.

The Murphy Bed, is now still placed at 2feet to 3feet, from the wall.

The 2 adults, upon attachment the Bed Frame to the Bed Cabinet, shall get the Pistons, and move to the back of the Murphy Bed. Both persons shall - then attach the Pistons to the Bed Frame and Bed Cabinet.

You may need to – LIGHTLY slide forward-backward to adjust and create gap space so as to enable the Pistons to be hooked to both ends of the hanging bolts in the Inner Wall of the L-BRACKET

Fully Secure and Tighten these Bolts at each end of the Pistons.

J.) Attachment of Safety Latches.

Upon completion of Step I above, ensure the entire structure of Bed Frame to Cabinet is fully and securely attached as ONE UNIT – affix the Safety Latches.

These Latches are to be reachable by Adults Only. Thus, the minimum height shall be no less than 5feet (1.5m) from ground.

K.) POSITIONING THE MURPHY BED INTO ITS FINAL POSITION.

At this juncture, the Murphy Bed is ASSEMBLED BUT NOT AS A FULL & COMPLETE piece of furniture AND NOT FUNCTIONAL AS A BED YET, as it is NOT SECURED TO THE WALL.

DO NOT ATTEMPT TO OPEN THE MURPHY BED AND OR TEST SLEEP AND OR LIE-INTO the Murphy Bed.

ALL 4 (four) adults shall now move the entire Murphy Bed to the FINAL DESIGNATED Position, matching to the previously marked “SCREW-IN” positions in the walls.

L) ATTACHMENT OF MURPHY BED TO WALL.

With the Murphy Bed now in its final designated spot, 2 adult persons shall continue to hold down the entire Murphy Bed.

REMINDER : FOLLOW the INSTRUCTIONS from your Professional Consultant / Contractor.

Position the Ladder (where necessary) and FULLY & SECURELY turn in the BOLTS or SCREWS into the CONCRETE WALL or WOODEN STUDS or STEEL STUDS.

SEQ	Bed Description	Bed Size	Details.
1	Single/Twin(XL)	~38*75/80~ inches	Attach at least 2 pieces of L or Z Hardware onto the Wall or Studs;
2	Full	54*75inches	Install at least 3 pieces of L or Z Hardware onto the Wall or Studs;
3	Queen	60*80inches	Install at least 3 pieces of L or Z Hardware onto the Wall or Studs;
4	King	76*80inches	Install at least 4 pieces of L or Z Hardware onto the Wall or Studs;
5	Other Bed Size		Other Bed Sizes - seek advice from your Contractor

Recommended Mattress weight 77 lb or 35 kg / Recommended Mattress thickness 6 - 8 inches or 15.2 – 20.3 cm - Your Murphy Bed is made having taken into consideration the Bed Frame Weight and Mattress weight to pair with the Pistons Newton Force.

Therefore, load your bed with the RECOMMENDED MATTRESS Weights, Size and Thickness as stated here in the assembly instructions.

DO NOT LOAD any heavier and or LARGER and or LIGHTER Mattress than what is recommended here.

M.) MATTRESS PLACEMENT .

Only after the Murphy Bed is FULLY SECURED to the wall, the 2 adult persons who are holding down the entire Murphy Bed, can now be released for this action.

Have 1 to 2 persons – place equal strengths to the handles and gently and securely, PULL DOWN the Bed Frame until the Bed Frame is horizontally and level to the ground.

Have the other 2 persons – carry and place the Mattress (**within the recommended weight and thickness**) and gently place the Mattress on to the Bed Frame.

N) PISTON NEWTON-LOAD STRENGTH.

You are hereby reminded that when the BED FRAME is EMPTY OF MATTRESS, the Bed Frame may NEED a STRONGER force to be pulled down before you can place the Mattress.

This RESISTANCE to be PULLED DOWN is a normal characteristics of the Pistons Newton-Load force is “in action”.

O) BED STRAP – GUIDE STRAP

Your Murphy Bed may or may not come equipped with a Bed Strap.

This Bed Strap serves as a GUIDE STRAP to help you lift the Bed Frame some 6 inches or so off its resting position. Then use both hands to FULLY LIFT HOIST the Bed Frame to its closing position.

SAFETY REMINDER :

1.) **DO NOT USE THE BED STRAP** to PULL DOWN TO OPEN the BED FRAME from its CLOSED POSITION.
2.) **DO NOT USE THE BED STRAP** to PULL-LIFT-HOIST the BED FRAME from the OPENED-HORIZONTAL position, to the CLOSED POSITION.

Both the above may cause injury and or unnecessary strain to your arm(s).

P.) USING YOUR MURPHY BED.

For EVERY USE – exercising Safety Precautionary Measures to ensure the safety of your family members and pets **are IMPORTANT.**

Therefore, PRIOR TO OPENING / PRIOR TO CLOSING OF YOUR MURPHY BED - Make sure all Children / Non Ambulatory Persons and Pets are at bay.

KEEP CHILDREN and NON-AMBULATORY persons from Unlatching the Safety Latches.

Q.) CAUTION : DO NOT BE DISTRACTED During EVERY OPENING and CLOSING of your Murphy Bed.

Every time you Pull to **OPEN** the Murphy Bed from its closed position OR **Lift-Pull to CLOSE** the Murphy Bed to stow it into the Bed Cabinet -

- give these actions your focused and dedicated attention.
- **DURING EVERY OPENING and CLOSING of your Murphy Bed** - always ensure you have an Adult Partner close by for added assistance, where necessary.
- **DO NOT OVER EXERT ADDED FORCE to OPEN the Bed or to CLOSE the Bedframe.** For if you do, the resistance of the Piston will only make it harder for you to complete the task.
- **TO CLOSE the Murphy Bed** : depending on your height – stand some 6 inches to 10 inches away from the FootBoard edge. Use both your hands and place both hands at about equal distance from the middle of the Bed Frame, spaced at 2 to 3 feet between your hands - GENTLY LIFT-PULL to Close your Murphy Bed.
- **TO OPEN the Murphy Bed** : using equal force – place your hands to the installed grab handle and GENTLY PULL towards you to Open. As you pull Open the Murphy Bed – proceed to move backwards, slowly and steadily, so as to give way to the Murphy Bed's OPEN Position.

- During **EVERY OPENING or CLOSING** of the Murphy Bed - at about your hip level - you may find that you need to rotate your hand / wrist - take caution here to prevent injury.
- During EVERY OPENING and CLOSING, keep Children and Pets and Non Ambulatory Persons at bay.
- **NEVER** allow your children to treat this Murphy Bed as a Hide and Seek place of fun or jump on the bed.
- **Care & Maintenance** - Depending on the frequency of use of your Murphy Bed, it is recommended that you take precautionary Care and Maintenance. It is advisable to conduct NO LESS THAN 2 to 3 checks annually on these mounting points & pistons to ensure that these are securely bolted. Where necessary, use a vacuum cleaner to clear all dust and then wipe down with a damp cloth, then proceed with your maintenance work.

Safety Latches - Your Murphy Bed comes with two (2) Safety Latches. These are to be attached at, both the TOP LEFT and TOP RIGHT hand upper portion, **minimum of 5 feet (1.5m) from ground**, of the Bed Frame / Bed Cabinet. Monitor and Inspect these frequently.

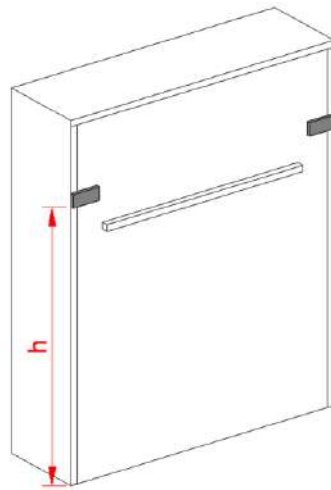

- Whenever NOT in use and after the Murphy Bed has been LIFTED and stowed in its **CLOSED POSITION - ALWAYS LATCH UP.**

Frequently Asked Questions.

Malfunctioned Pistons.

How do you know when the Murphy Bed's Piston has malfunctioned?

It would be quite evident in that :

- a.) the Bed Frame may become **LOPSIDED** and
- b.) the Lift-PULL force to **CLOSE** may be "heavier" than before.

IMMEDIATELY - STOP USING YOUR MURPHY BED.

SEEK and CONSULT professional maintenance service to ascertain the problem and repair and or have the pistons changed.

DOSSIER D'INFORMATIONS IMPORTANTES

**CE DOSSIER CONTIENT DES AVERTISSEMENTS ET DES
INFORMATIONS SUR LA SÉCURITÉ DU PRODUIT.**

NE POURSUIVEZ PAS SANS L'AVOIR LU ATTENTIVEMENT.

A. ÉTIQUETTES D'AVERTISSEMENT.

Votre lit escamotable acheté vous est livré avec des **ÉTIQUETTES D'AVERTISSEMENT** afin de vous rappeler constamment de prendre et d'adopter des mesures de sécurité tout au long de l'assemblage et aux points de fixation du lit au mur.

NE RETIREZ PAS ces étiquettes.

Ces étiquettes d'avertissement servent d'outil de rappel pour les amis et les proches en visite lorsqu'ils utilisent le lit escamotable, afin de garantir que les précautions de sécurité sont respectées.



WARNING.

IMPORTANT SAFETY REQUIREMENTS - Bed Attachment to Wall. For Your Safety, the Murphy bed MUST BE ATTACHED to the Wall.

Seek Certified Professional Consultant / Contractors for their Services to:

- 1.) DETERMINE the WALL Type in Your Home;
- 2.) PRECISE HARDWARE that suits to the Wall Type in Your Home;
- 3.) INSTALL / ATTACH of the Murphy Bed to the Wall in Your home;
- 4.) VALIDATE the Murphy Bed is appropriately and securely installed/attached.

The choice of wall anchoring hardware depends on the type of wall. This Murphy Bed is delivered with **HARDWARE SCREWS** suited for attachment to **WOOD STUDS** in walls. Any **STUDS** type detected with your Consultant-Contractors to be **NOT WOOD STUDS** - **DISCARD** and **DO NOT USE** these **SCREWS**. Use the hardware suitable for your wall material.

Seek the professional advice of your Consultant-Contractor and procure the appropriate hardware and brackets for the attachment of the Murphy Bed to the Wall.

FAILURE TO ADHERE TO THE ABOVE INSTRUCTIONS MAY RESULT IN SERIOUS and/or SEVERE INJURIES or Death caused by the detachment of the Murphy Bed from the Wall.

SAFETY PRECAUTION :

1.) MAXIMUM Mattress Weight suited to your Murphy Bed: 77 lbs (35 kg);
MAXIMUM mattress thickness: 6-8inches (15.2 – 20.3cm);
2.) ENSURE ADULTS ONLY throughout the entire assembly and attachment
3.) KEEP ALL Children, Non-Ambulatory persons and Pets at bay during the entire assembly and attachment

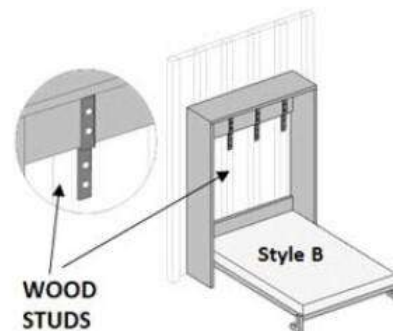
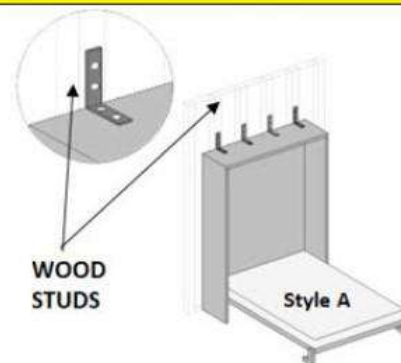

LINE ART for Reference only and
NOT DRAWN TO SCALE.

ATTENTION : Les maisons sont rénovées de manière différente. Il existe des murs en **BÉTON** et des **murs creux**. Les murs creux sont renforcés avec des **montants** en matériaux en bois ou en acier. Consultez des professionnels.

Style A - Lit Murphy VERTICAL avec panneau arrière SCELLÉ/FERMÉ

Style B - Lit Murphy VERTICAL avec panneau arrière de STYLE OUVERT

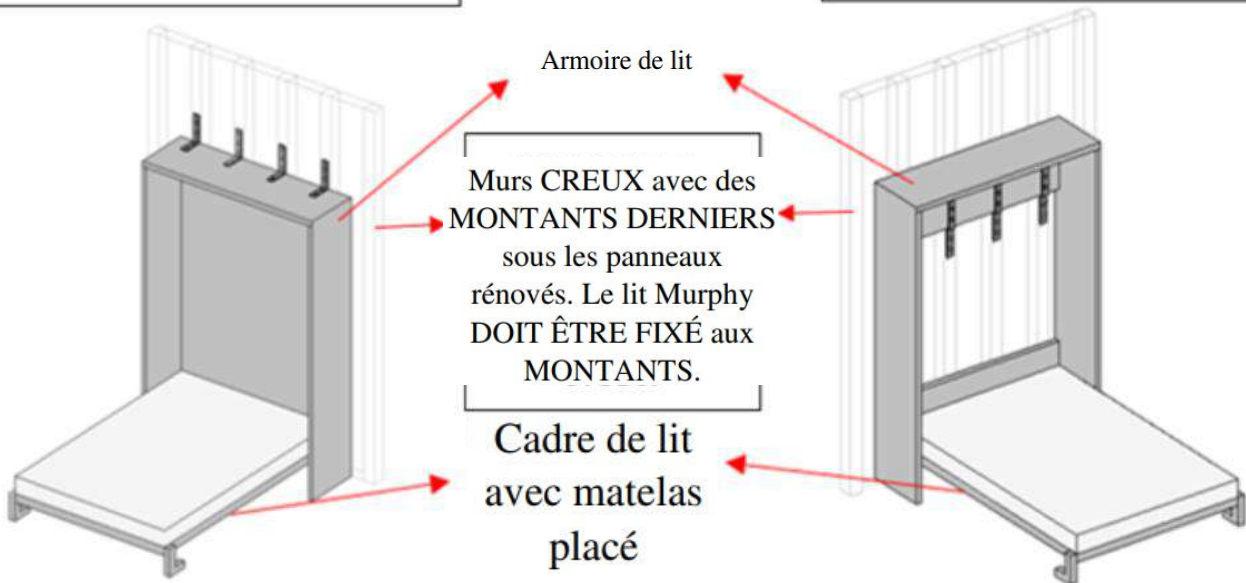

B.) RAPPELS DE SÉCURITÉ. **REPÈRES SUR LE MUR – OÙ FIXER LE LIT** **ESCAMOTABLE.**

Peu importe le type de mur, qu'il s'agisse de murs en béton plein OU de murs décoratifs avec montants en BOIS OU de murs décoratifs avec montants en MÉTAL, assurez-vous que :

- a.) vous choisissez un installateur professionnel ayant une bonne compréhension de la structure du mur sur lequel le lit escamotable est fixé, y compris la position des montants et des éléments structurels dans le cas d'une structure en bois ou en métal.**
- b.) des repères précis des points d'ancrage soient faits sur le mur pour une identification facile lors de la fixation du lit escamotable.**
- c.) la quincaillerie appropriée ainsi que les supports métalliques soient PRÊTS pour cette fixation et facilement accessibles pour permettre une fixation rapide et efficace.**

Ce produit nécessite une consultation et une installation professionnelles*.

* Lorsque vous choisissez un installateur professionnel, assurez-vous de respecter toutes les lois, réglementations et règles en vigueur dans la ville, l'État ou le pays où le lit escamotable est installé.

Pour assembler entièrement votre lit escamotable et en garantir le bon fonctionnement, vous **DEVEZ LIRE** entièrement ce manuel d'instructions de montage avant de commencer l'assemblage du lit.

1.) **Il existe de nombreux problèmes de sécurité et mesures de précaution que vous DEVEZ CONNAÎTRE avant de commencer l'assemblage.**

2.) **ATTENTION – Le non-RESPECT / le non-SUIVI du GUIDE, des AVERTISSEMENTS et des RAPPELS mentionnés ici peut entraîner des blessures graves / sévères, voire la mort.**

3.) **PRÉCAUTION : Pour l'assemblage, seuls des partenaires adultes doivent participer à l'ensemble de l'assemblage. Assurez-vous que SEULEMENT 4 (quatre) à 6 (six) PERSONNES EN BONNE CONDITION PHYSIQUE participent à l'assemblage complet et à la fixation de ce lit escamotable aux murs de votre domicile.**

4.) **ATTENTION : Pendant tout le processus d'assemblage et la fixation du lit escamotable aux murs de votre domicile, TENEZ TOUS les enfants, les personnes non autonomes et les animaux de compagnie STRICTEMENT À L'ÉCART.**

5.) **RAPPEL DE SÉCURITÉ concernant / à : Vous-même, les membres de la famille et les animaux de compagnie. Le lit escamotable peut vous être livré en 3 à 5 colis et ils sont LOURDS. Chaque carton contient de nombreuses pièces et composants. Certains de ces composants, par exemple les boulons et les vis, sont de taille relativement petite*.**

* Pendant le processus d'assemblage, veillez à ramasser tous les boulons et écrous égarés afin que les enfants et/ou les animaux de compagnie ne jouent pas avec ou ne les avalent pas.

6.) Ce lit escamotable est destiné **UNIQUEMENT** à une **UTILISATION PAR DES ADULTES**.

7.) Ce lit escamotable vous est livré préemballé avec la quincaillerie – adaptée **UNIQUEMENT** aux murs à ossature en bois rénovés avec des **MONTANTS EN BOIS**.

8.) **Type de mur de votre domicile** – Chaque maison est rénovée différemment, avec des types et des finitions de murs variés. Avant de procéder à l'assemblage de votre lit escamotable:

- a.) **SOLLICITEZ et CONSULTEZ des services professionnels pour** déterminer le type de mur à l'endroit prévu pour la fixation du lit escamotable ;
- b.) **ASSUREZ-VOUS** que le consultant ou l'entrepreneur vous **INFORME PRÉCISÉMENT** du **TYPE DE MUR** à l'endroit prévu pour la fixation du lit escamotable.
- c.) **ASSUREZ-VOUS** que le consultant vous **INFORME PRÉCISÉMENT** sur la quincaillerie et les supports **ADAPTÉS et APPROPRIÉS** pour fixer et sécuriser le lit escamotable au mur.

9.) **AVERTISSEMENT – VOUS DEVEZ SUIVRE LES INSTRUCTIONS** fournies par le consultant ou l'entrepreneur que vous avez désigné concernant :

- a.) Type de quincaillerie de fixation adapté au(x) type(s) de mur – si le mur **N'EST PAS** composé de **MONTANTS EN BOIS**, les vis fournies pour les murs à montants en bois ne conviendront **PAS / ne seront PAS** adaptées.
- b.) Nombre de points de fixation du lit escamotable au mur.

ATTENTION : Les maisons sont rénovées de manière différente. Il existe des murs en **BÉTON** et des **murs creux**. Les murs creux sont renforcés avec des **montants** en matériaux en bois ou en acier. Consultez des professionnels.

Style A - Lit Murphy VERTICAL avec panneau arrière **SCELLÉ/FERMÉ**

Style B - Lit Murphy VERTICAL avec panneau arrière de **STYLE OUVERT**

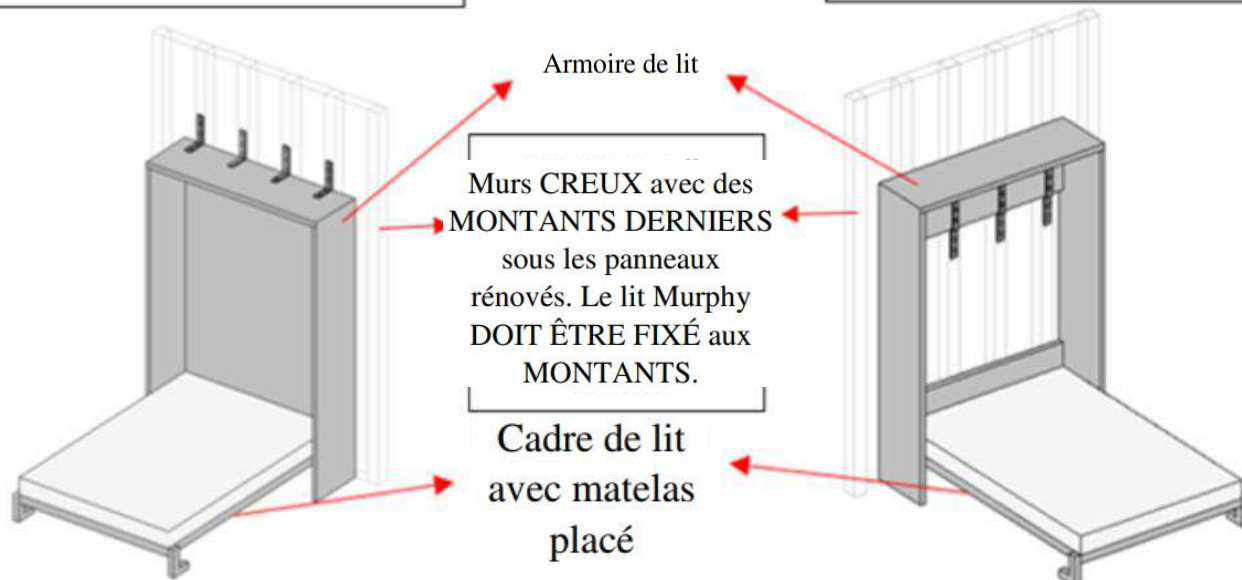

10.) Ce lit escamotable est conçu pour une utilisation domestique et n'est pas destiné à un usage commercial.

11.) Ce lit escamotable n'est pas destiné à être déplacé, modifié, désinstallé ou démonté une fois installé par un professionnel.

C.) INFORMATIONS DE MONTAGE & QUINCAILLERIE.

1.) **RAPPELS :**

- a.) Dans le cas où ce jeu de vis préemballé ne conviendrait pas aux murs de votre domicile – **NE LES UTILISEZ PAS / JETEZ cette quincaillerie.**
- b.) **RESPECTEZ les instructions et les informations fournies par le consultant ou l'entrepreneur professionnel concernant la quincaillerie de fixation APPROPRIÉE à votre mur.**
- c.) L'approvisionnement de cette quincaillerie APPROPRIÉE relève d'un accord entre vous et votre consultant ou entrepreneur.

2.) Un escabeau (non fourni) est nécessaire pour fixer les équerres en L au mur, en haut du lit escamotable. **NE VOUS APPUYEZ PAS** sur le haut du lit escamotable, cela pourrait provoquer un affaissement.

Lit escamotable Style A

Fixation des équerres en L sur des montants en bois

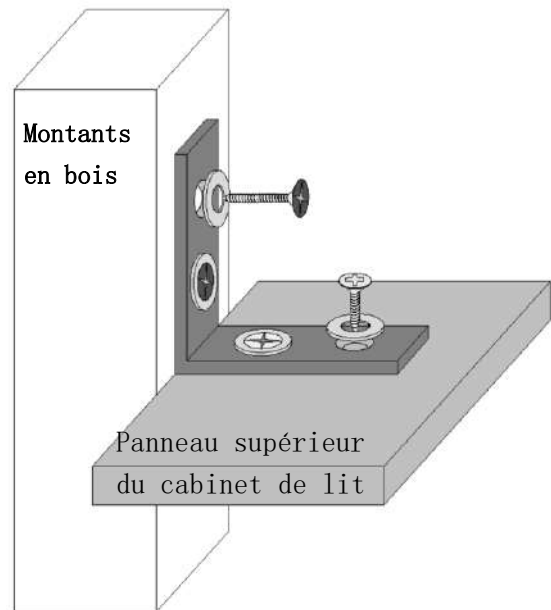
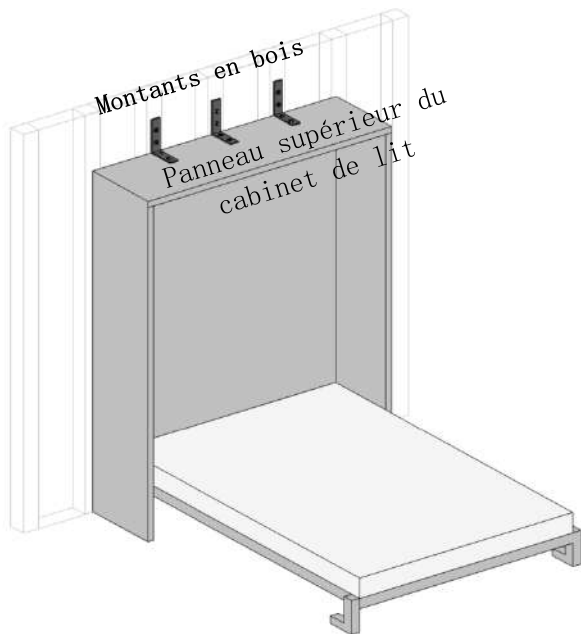

Z- Fixation des supports sur des montants en bois

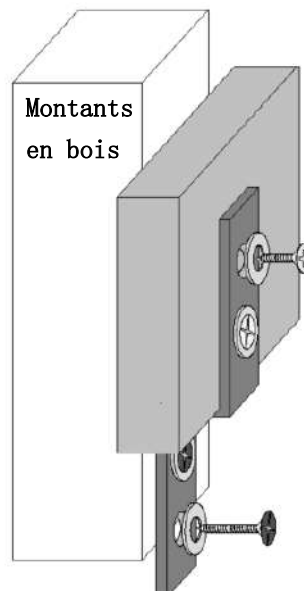
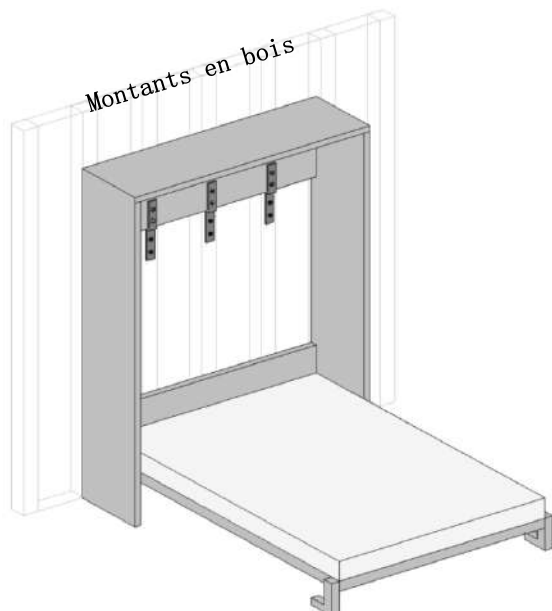

D.) IDENTIFICATION des OUTILS et **COMPÉTENCES de FIXATION.**

Les pièces et composants nécessaires sont indiqués dans les instructions de montage. Suivez-les attentivement.

Pour un assemblage efficace, après avoir ouvert les cartons :

- a.) Disposez toutes les pièces et composants dans l'ordre ;
- b.) Vérifiez que chaque pièce, élément de quincaillerie et composant est présent ;
- c.) Placez les pièces à proximité les unes des autres.

Assemblez et serrez chaque boulon, écrou et vis à environ 80 % pour maintenir ensemble le cadre du lit et l'armoire.

Lors de l'assemblage final, lorsque tout est ajusté correctement et dans le bon ordre, serrez progressivement chaque boulon, écrou et vis.

ATTENTION :

- 1.) **LES PLAQUES MÉTALLIQUES sur les côtés des longerons – DOIVENT ÊTRE COMPLÈTEMENT et SOLIDEMENT FIXÉES aux LONGERONS.**
- 2.) **Les ÉQUERRES EN L des pistons fixées à la PAROI INTÉRIEURE de l'armoire du lit – DOIVENT ÊTRE COMPLÈTEMENT et SOLIDEMENT FIXÉES à ces PAROIS INTÉRIEURES.**
- 3.) **Ces PLAQUES MÉTALLIQUES et ÉQUERRES EN L – sont les composants qui maintiennent les pistons permettant au lit de se “déplacer” en position OUVERTE ou FERMÉE.**
- 4.) **INSPECTIONS FRÉQUENTES de ces PLAQUES MÉTALLIQUES / ÉQUERRES et des BOULONS des pistons, jusqu'à une fois par mois – afin de s'assurer qu'ils NE SE DESSERRENT PAS. Car si ces boulons du cadre du lit et/ou de l'armoire du lit ou des pistons sont desserrés, cela peut entraîner le DÉSENGAGEMENT du CADRE DU LIT et causer des blessures.**

RAPPEL : NE JAMAIS SERRER COMPLÈTEMENT une vis / un écrou ou un boulon en une seule fois. Si vous SERRER complètement la quincaillerie jusqu'au cœur du bois, cela peut entraîner un DÉALIGNEMENT des pièces, ce qui empêchera les autres éléments de s'ajuster correctement à leurs points de fixation lors de l'assemblage.

E. TOUS LES TRAVAUX D'ASSEMBLAGE **NÉCESSITENT UNE ÉQUIPE D'AU MOINS 4** **ADULTES.**

Reminder : Comme indiqué ci-dessus, les cartons et les produits sont lourds – par conséquent, faites preuve de prudence en tout temps et ASSUREZ-VOUS D'AVOIR VOTRE ÉQUIPE DE 4 personnes pour l'ENSEMBLE DE L'ASSEMBLAGE.

F.) ASSEMBLAGE DU CADRE DE LIT.

Identifiez toutes les pièces et composants du cadre de lit.

Assemblez le cadre de lit conformément aux instructions de montage.

Une fois l'assemblage du cadre de lit terminé, effectuez une inspection finale pour vous assurer que toutes les jonctions et pièces sont complètement et solidement fixées.

Ensuite, placez le cadre de lit entièrement assemblé à plat sur le sol, à environ 3 mètres de la zone d'installation de l'armoire du lit, afin de laisser suffisamment d'espace pour l'assemblage de celle-ci.

G.) ASSEMBLAGE DE L'ARMOIRE DU LIT.

Identifiez toutes les pièces et composants de l'armoire du lit.

Assemblez l'armoire du lit conformément aux instructions de montage.

Une fois l'assemblage de l'armoire du lit terminé, effectuez une inspection finale pour vous assurer que toutes les jonctions et pièces sont complètement et solidement fixées.

NETTOYEZ tous les débris dans la zone où le lit escamotable sera fixé au mur.

Déplacez cette ARMOIRE DE LIT ENTIÈREMENT ASSEMBLÉE et positionnez-la à environ 60 à 90 cm du mur désigné, là où vous avez précédemment effectué les marquages.

SAFETY REMINDER – L'armoire n'est PAS ENCORE FIXÉE AU MUR. À partir de ce moment-là – VOUS DEVEZ AVOIR 2 ADULTES pour MAINTENIR et STABILISER cette ARMOIRE DE LIT afin d'éviter qu'elle ne BASCULE..

H. FIXATION DU CADRE DE LIT À L'ARMOIRE DE LI.

Safety Reminder : VEILLENZ À CE QUE les 2 adultes tenant l'armoire du lit RESTENT EN POSITION EN TOUT TEMPS.

Les 2 autres adultes devront soulever et porter le cadre de lit pour le fixer aux équerres en L – à l'intérieur de l'armoire du lit.

Ensuite, relevez doucement le cadre de lit en POSITION FERMÉE.

I.) FIXATION DES PISTONS POUR MAINTENIR ET SOUTENIR L'ARMOIRE DE LIT AU CADRE DE LIT.

Le lit escamotable est encore placé à une distance de 60 à 90 cm du mur.

Les 2 adultes, après avoir fixé le cadre de lit à l'armoire du lit, devront prendre les pistons et se déplacer à l'arrière du lit escamotable. Les deux personnes devront ensuite fixer les pistons au cadre de lit et à l'armoire de lit.

Il peut être nécessaire de faire glisser LÉGÈREMENT l'ensemble d'avant en arrière afin d'ajuster et de créer un espace permettant d'accrocher les pistons aux deux extrémités des boulons suspendus dans la paroi intérieure de l'ÉQUERRE EN L.

Fixez et serrez complètement ces boulons à chaque extrémité des pistons.

J.) Fixation des loquets de sécurité.

Une fois l'étape I ci-dessus terminée, assurez-vous que toute la structure du cadre de lit et de l'armoire soit complètement et solidement fixée en UNE SEULE UNITÉ – installez les loquets de sécurité.

Ces loquets doivent être accessibles uniquement par des adultes. Par conséquent, la hauteur minimale doit être d'au moins 1,5 mètre (5 pieds) à partir du sol.

K.) PLACEMENT DU LIT ESCAMOTABLE DANS SA POSITION FINALE.

À ce stade, le lit escamotable est ASSEMBLÉ MAIS PAS ENCORE UNE PIÈCE DE MOBILIER COMPLÈTE ET FONCTIONNELLE EN TANT QUE LIT, car il N'EST PAS ENCORE FIXÉ AU MUR.

NE TENTEZ PAS D'OUVRIR LE LIT ESCAMOTABLE NI D'Y DORMIR OU DE VOUS Y ALLONGER.

LES 4 adultes doivent maintenant déplacer l'ensemble du lit escamotable vers la POSITION FINALE DÉSIGNÉE, en l'alignant avec les emplacements de vissage marqués précédemment sur le mur.

L) FIXATION DU LIT ESCAMOTABLE AU MUR.

Maintenant que le lit escamotable est à son emplacement final désigné, 2 adultes devront continuer à maintenir fermement l'ensemble du lit escamotable.

RAPPEL : SUIVEZ les INSTRUCTIONS de votre consultant / entrepreneur professionnel.

Positionnez l'échelle (si nécessaire) et VISSER COMPLÈTEMENT ET SÉCURISÉMENT les BOULONS ou VIS dans le MUR EN BÉTON, les MONTANTS EN BOIS ou les MONTANTS EN ACIER.

SEQ	Descriptions du lit	Taille du lit	Détails
1	Single/Twin(XL)	~38*75/80~ inches	fixez au moins 2 pièces de matériel en L ou en Z sur le mur ou les montants :
2	Full	54*75inches	fixez au moins 3 pièces de matériel en L ou en Z sur le mur ou les montants :
3	Queen	60*80inches	fixez au moins 3 pièces de matériel en L ou en Z sur le mur ou les montants :
4	King	76*80inches	fixez au moins 4 pièces de matériel en L ou en Z sur le mur ou les montants :
5	Autres tailles de lit		Autres tailles de lit - demandez conseil à votre entrepreneur.

Poids recommandé du matelas : 35 kg (77 lb) / Épaisseur recommandée du matelas : 15,2 à 20,3 cm (6 à 8 pouces) – Votre lit escamotable a été conçu en tenant compte du poids du cadre de lit et du matelas, afin de correspondre à la force en Newton des pistons.

Par conséquent, utilisez un matelas avec le POIDS, la TAILLE et l'ÉPAISSEUR RECOMMANDÉS comme indiqué dans les instructions de montage.

NE CHARGEZ PAS de matelas plus lourd, plus grand ou plus léger que ceux recommandés ici.

M.) PLACEMENT DU MATELAS.

Ce n'est qu'une fois le lit escamotable COMPLÈTEMENT FIXÉ au mur que les 2 adultes qui le maintenaient peuvent être libérés pour cette étape.

Faites en sorte que 1 à 2 personnes tirent doucement et fermement sur les poignées pour abaisser le cadre de lit jusqu'à ce qu'il soit horizontal et de niveau avec le sol.

Les 2 autres personnes devront soulever et placer le matelas (**respectant le poids et l'épaisseur recommandés**) et le déposer délicatement sur le cadre du lit.

N) FORCE DE CHARGE EN NEWTON DES PISTONS.

Il vous est rappelé que lorsque le CADRE DE LIT EST SANS MATELAS, il peut FALLOIR UNE FORCE PLUS FORTE pour l'abaisser avant de pouvoir y placer le matelas.

Cette RÉSISTANCE lors de la DESCENTE est une caractéristique normale du fonctionnement de la force de charge en Newton des pistons.

O) SANGLE DE LIT – SANGLE DE GUIDAGE

Votre lit escamotable peut être ou non équipé d'une sangle de lit.

Cette sangle de lit sert de SANGLE DE GUIDAGE pour vous aider à soulever le cadre de lit d'environ 15 cm depuis sa position de repos. Ensuite, utilisez les deux mains pour SOULEVER COMPLÈTEMENT le cadre de lit jusqu'à sa position fermée.

RAPPEL DE SÉCURITÉ:

1.) **NE PAS UTILISER LA SANGLE DE LIT pour TIRER VERS LE BAS afin d'OUVRIER LE CADRE DE LIT depuis sa POSITION FERMÉE.**
2.) **NE PAS UTILISER LA SANGLE DE LIT pour TIRER-SOULVER-HISSER LE CADRE DE LIT depuis la POSITION OUVERTE-HORIZONTALE vers la POSITION FERMÉE.**

Les deux actions ci-dessus peuvent provoquer des blessures et/ou une tension inutile au niveau de vos bras.

P.) UTILISATION DE VOTRE LIT ESCAMOTABLE.

À CHAQUE UTILISATION – il est IMPORTANT de prendre des mesures de précaution pour garantir la sécurité de vos proches et de vos animaux domestiques.

Par conséquent, AVANT D'OUVRIER / AVANT DE FERMER VOTRE LIT ESCAMOTABLE – assurez-vous que tous les enfants, les personnes à mobilité réduite et les animaux sont tenus à l'écart.

EMPÊCHEZ LES ENFANTS et les personnes à mobilité réduite de DÉVERROUILLER les loquets de sécurité.

Q.) ATTENTION : NE VOUS LAISSEZ PAS DISTRAIRE lors de CHAQUE OUVERTURE et FERMETURE de votre lit escamotable.

Chaque fois que vous tirez pour OUVRIER le lit escamotable depuis sa position fermée ou que vous le SOULEVEZ-TIREZ pour le FERMER dans son armoire :

- Faites ces gestes avec **toute votre attention et concentration.**
- LORS DE CHAQUE OUVERTURE ET FERMETURE du lit escamotable, assurez-vous **qu'un autre adulte** soit présent à proximité pour vous assister si besoin.
- **NE FORCEZ JAMAIS EXCESSIVEMENT** pour ouvrir ou fermer le lit. Une trop grande force exercée contre la résistance des vérins à gaz rendra l'action plus difficile et risquera d'endommager le système.
- POUR FERMER le lit escamotable : selon votre taille, tenez-vous à environ **15 à 25 cm** du bord du pied du lit. Utilisez **vos deux mains**, placées à **égale distance du centre du cadre**, espacées d'environ **60 à 90 cm** – et **SOULEVEZ-TIREZ DOUCEMENT** pour le fermer.

- POUR OUVRIR le lit escamotable : appliquez une force équilibrée avec les deux mains sur la poignée prévue à cet effet et **TIREZ DOUCEMENT vers vous**. Pendant que le lit s'abaisse, **reculer lentement et progressivement** pour accompagner le mouvement.
- À hauteur de hanche, lors de chaque ouverture ou fermeture, vous pourriez avoir à **faire pivoter votre main / poignet** : faites attention pour **éviter toute blessure**.
- **Gardez toujours les enfants, les animaux domestiques et les personnes à mobilité réduite éloignés** pendant l'ouverture et la fermeture.
- **NE LAISSEZ JAMAIS vos enfants jouer à cache-cache dans le lit** ou sauter dessus.

Entretien & Maintenance

Selon la fréquence d'utilisation, il est recommandé de procéder à **2 à 3 contrôles par an** des points de fixation et des vérins pour vérifier qu'ils sont bien serrés. Nettoyez les zones concernées avec un aspirateur puis un chiffon humide avant d'effectuer l'entretien.

Loquets de sécurité : votre lit escamotable est équipé de **deux (2) loquets de sécurité**, à installer en haut à gauche et en haut à droite du lit ou de l'armoire, à **au moins 1,5 m du sol**. Surveillez et inspectez ces loquets régulièrement.

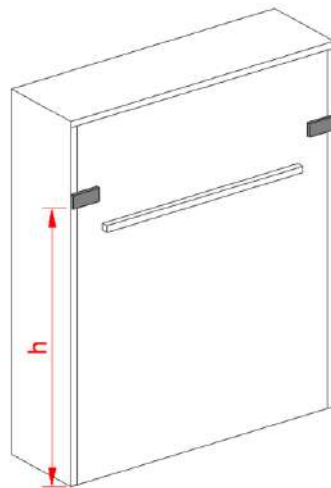

- **Lorsque le lit escamotable n'est pas utilisé et qu'il a été relevé et rangé en position fermée – VEILLEZ TOUJOURS À VERROUILLER LES LOQUETS.**

Questions Fréquemment Posées Vérins Défectueux.

Comment savoir si le vérin du lit escamotable est défectueux ?

Cela sera assez évident si :

- a.) Le cadre du lit devient **incliné** ;
- b.) La force nécessaire pour **soulever/fermer** le lit devient **plus lourde** qu'auparavant.

ARRÊTEZ IMMÉDIATEMENT d'utiliser le lit escamotable.

CONSULTEZ un service de maintenance professionnel pour diagnostiquer le problème et effectuer les réparations nécessaires ou remplacer les vérins.

ASSEMBLY INSTRUCTION

INSTRUCTIONS DE MONTAGE

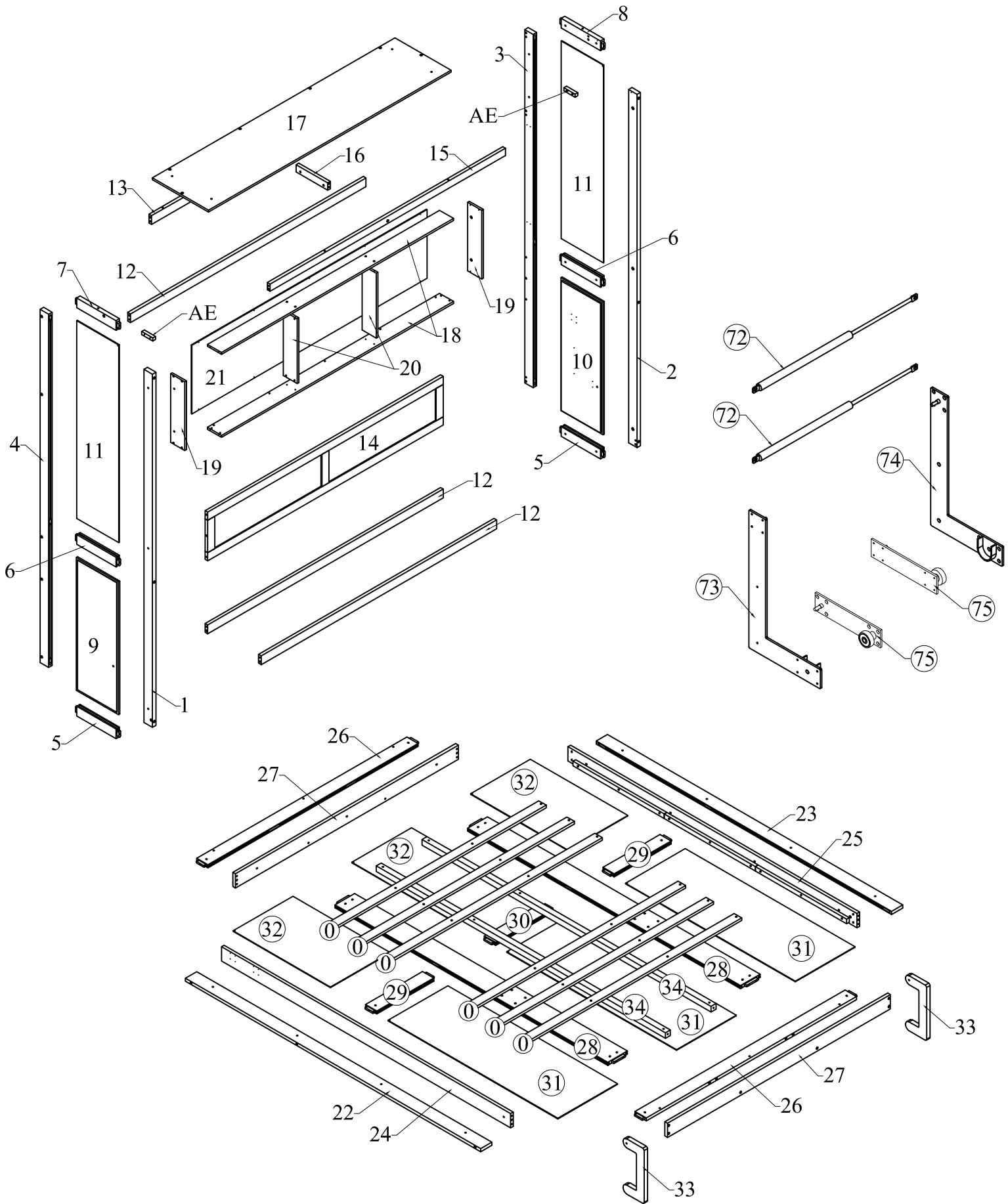





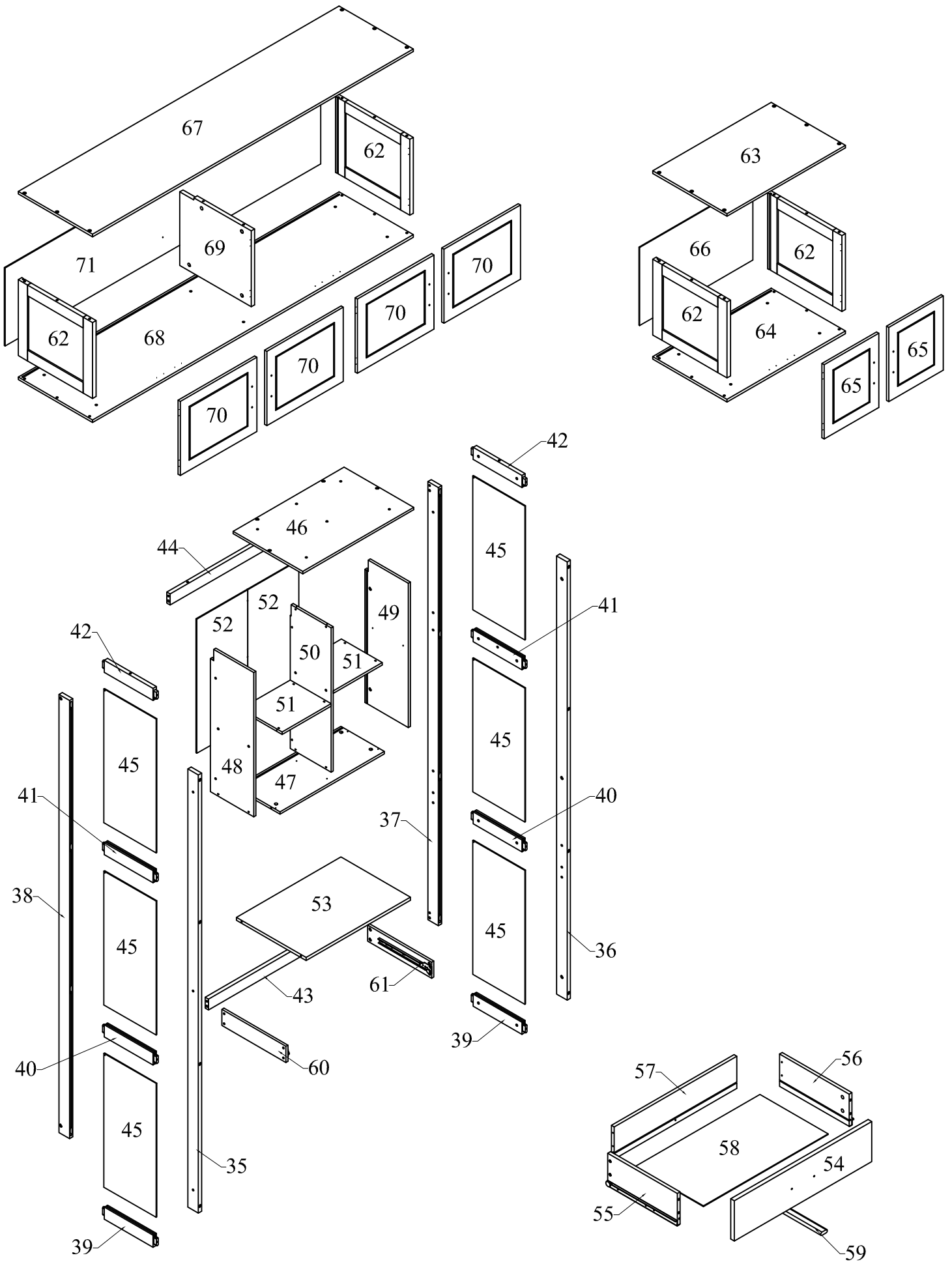

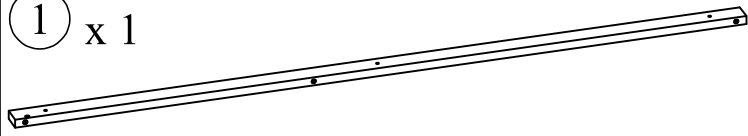
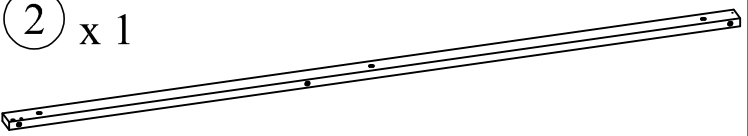

ASSEMBLY INSTRUCTION

INSTRUCTIONS DE MONTAGE

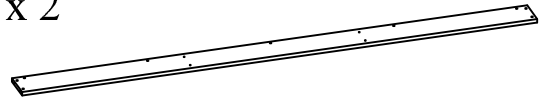

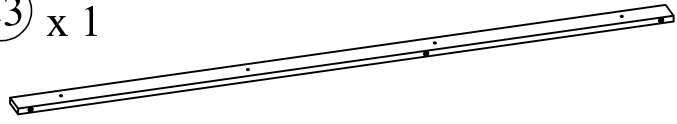
Part List (Box 1 - N708P392455)

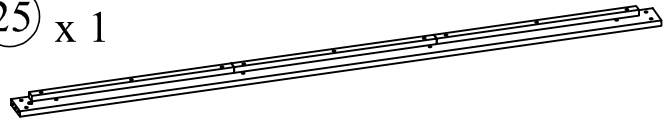
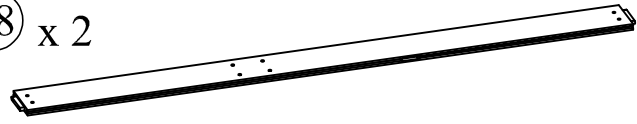
Liste des pièces (boîte 1- N708P392455)

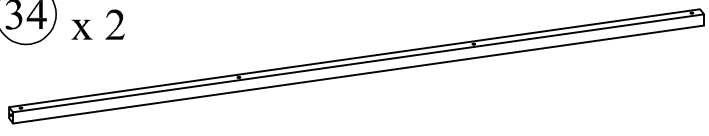
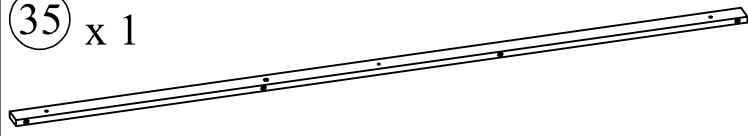
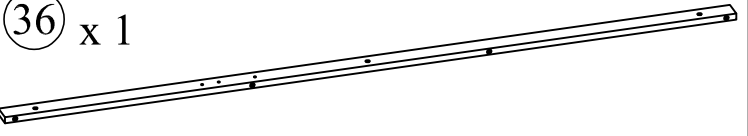
<p>① x 1</p>  <p>Front leg (left) Jambe avant (gauche)</p>	<p>② x 1</p>  <p>Front leg (right) Jambe avant (droite)</p>
<p>③ x 1</p>  <p>Back leg (right) Jambe arrière (droite)</p>	<p>④ x 1</p>  <p>Back leg (left) Jambe arrière (gauche)</p>
<p>⑱ x 2</p>  <p>Bookshelf bottom -top Bibliothèque bas-haut</p>	<p>⑲ x 2</p>  <p>Bookshelf side Côté bibliothèque</p>
<p>⑳ x 1</p>  <p>Front vertical rail Rail vertical avant</p>	<p>㉓ x 1</p>  <p>Front vertical rail Rail vertical avant</p>
<p>㉔ x 1</p>  <p>Side rail (left) Rail latéral (gauche)</p>	<p>㉕ x 1</p>  <p>Side rail (right) Rail latéral (droit)</p>
<p>㉘ x 2</p>  <p>Middle rail Rail intermédiaire</p>	<p>㉙ x 2</p>  <p>Crossbar Barre transversale</p>
<p>㉚ x 1</p>  <p>Crossbar Barre transversale</p>	<p>㉜ x 2</p>  <p>Support Soutien</p>
<p>㉝ x 1</p>  <p>Front leg (left) Jambe avant (gauche)</p>	<p>㉞ x 1</p>  <p>Front leg (right) Jambe avant (droite)</p>

Part List (Box 1 - N708P392455)

Liste des pièces (boîte 1- N708P392455)

37 x 1



Back leg (right)
Jambe arrière (droite)









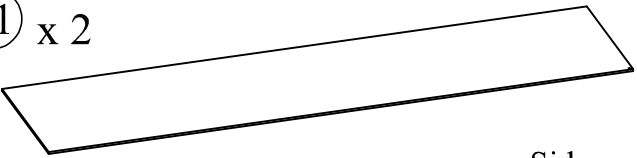

38 x 1

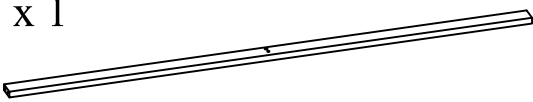
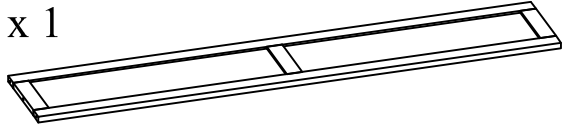
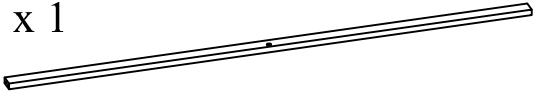
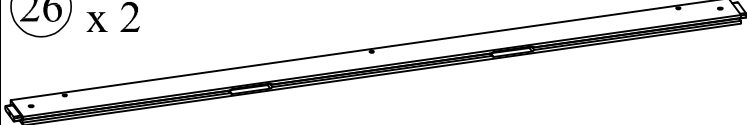
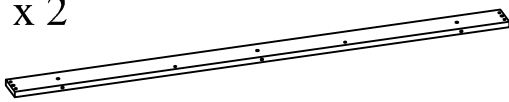

Back leg (left)
Jambe arrière (gauche)

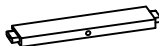
Part List (Box 2 - N708P392456)

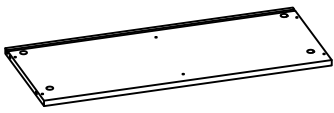
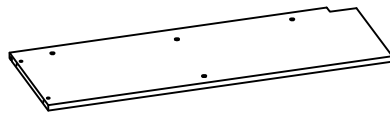
Liste des pièces (boîte 2- N708P392456)

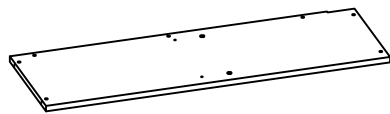
<p>⑪ x 2</p>  <p>Side panel Panneau latéral</p>	<p>⑫ x 3</p>  <p>Crossbar Barre transversale</p>
<p>⑬ x 1</p>  <p>Crossbar Barre transversale</p>	<p>⑭ x 1</p>  <p>Back frame Cadre arrière</p>
<p>⑮ x 1</p>  <p>Crossbar Barre transversale</p>	<p>⑯ x 2</p>  <p>Horizontal rail (front) Rail horizontal (avant)</p>
<p>⑰ x 2</p>  <p>Horizontal rail (front) Rail horizontal (avant)</p>	<p>⑳ x 2</p>  <p>Horizontal rail (bottom) Rail horizontal (bas)</p>
<p>㉑ x 2</p>  <p>Horizontal rail (middle) Rail horizontal (milieu)</p>	<p>㉒ x 2</p>  <p>Horizontal rail (middle) Rail horizontal (milieu)</p>
<p>㉓ x 2</p>  <p>Horizontal rail (top) Rail horizontal (haut)</p>	<p>㉔ x 6</p>  <p>Side panel Panneau latéral</p>
<p>㉕ x 1</p>  <p>Bookshelf bottom Fond de bibliothèque</p>	<p>㉖ x 1</p>  <p>Bookshelf side Côté bibliothèque</p>
<p>㉗ x 1</p>  <p>Bookshelf side Côté bibliothèque</p>	<p>㉘ x 1</p>  <p>Middle shelf Etagère du milieu</p>

Part List (Box 2 - N708P392456)

Liste des pièces (boîte 2- N708P392456)

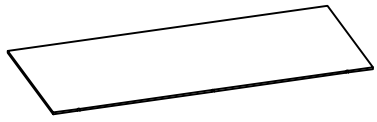
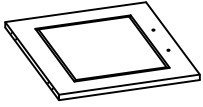
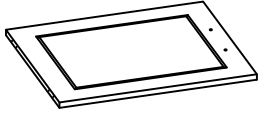
<p>51 x 2</p>  <p>Middle shelf Étagère du milieu</p>	<p>52 x 2</p>  <p>Bookshelf back Bibliothèque retour</p>
<p>65 x 2</p>  <p>Cabinet door Porte d'armoire</p>	<p>70 x 4</p>  <p>Cabinet door Porte d'armoire</p>





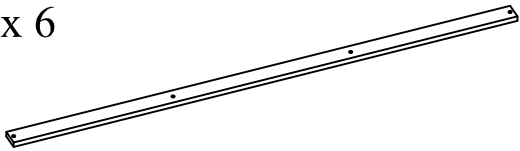
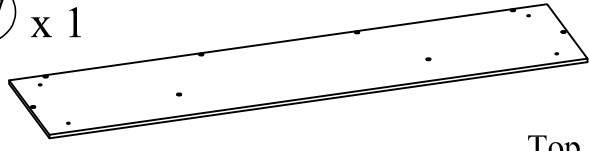
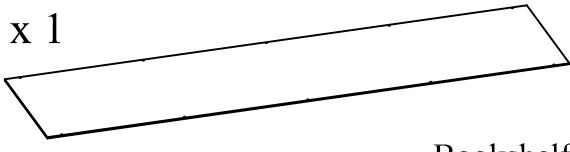
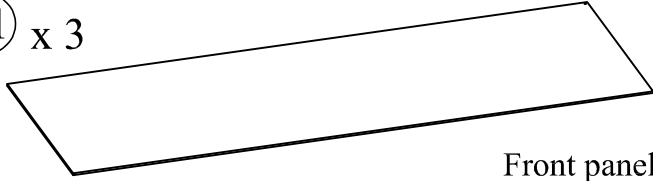
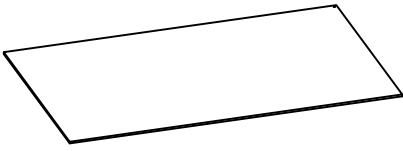
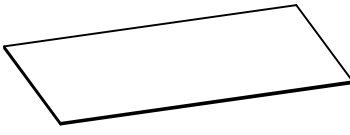
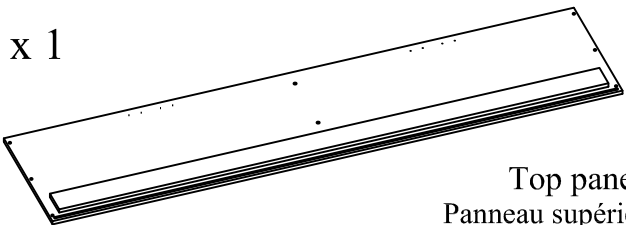
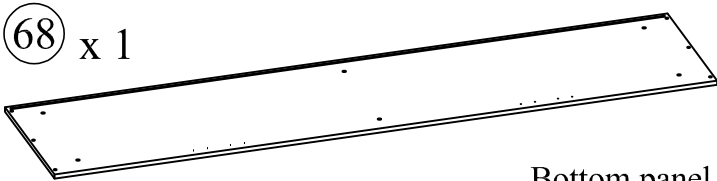
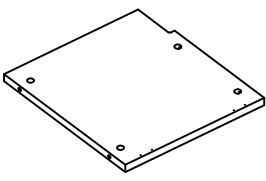
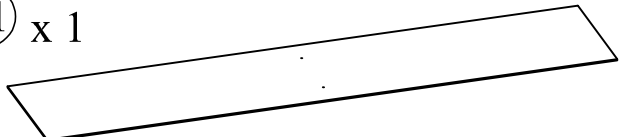





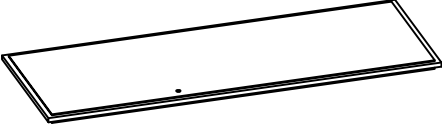
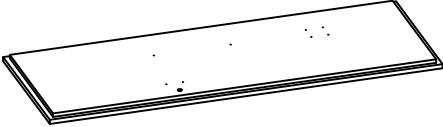

Part List (Box 3 - N708P392457)

Liste des pièces (boîte 3- N708P392457)

<p>① x 6</p>  <p>Slats lattes</p>	<p>①7 x 1</p>  <p>Top Panel Panneau supérieur</p>
<p>②1 x 1</p>  <p>Bookshelf back Bibliothèque retour</p>	<p>③1 x 3</p>  <p>Front panel Panneau avant</p>
<p>③2 x 3</p>  <p>Front panel Panneau avant</p>	<p>⑥6 x 1</p>  <p>Back panel Panneau arrière</p>
<p>⑥7 x 1</p>  <p>Top panel Panneau supérieur</p>	<p>⑥8 x 1</p>  <p>Bottom panel Panneau inférieur</p>
<p>⑥9 x 1</p>  <p>Divider panel Panneau de séparation</p>	<p>⑦1 x 1</p>  <p>Back panel Panneau arrière</p>



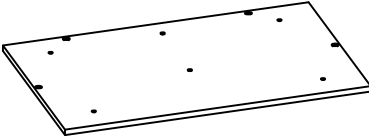
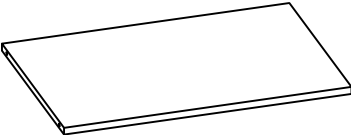
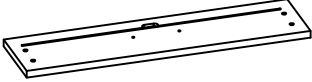



Part List & Hardware List (Box 4 - N708P392458)

Liste des pièces & Liste du matériel (boîte 4- N708P392458)

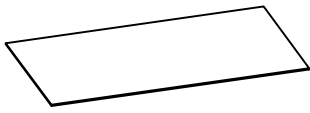
<p>⑤ x 2</p>  <p>Horizontal rail (bottom) Rail horizontal (en bas)</p>	<p>⑥ x 2</p>  <p>Horizontal rail (middle) Rail horizontal (milieu)</p>
<p>⑦ x 1</p>  <p>Horizontal rail (top) Rail horizontal (haut)</p>	<p>⑧ x 1</p>  <p>Horizontal rail (top) Rail horizontal (haut)</p>
<p>⑨ x 1</p>  <p>Left panel (bottom) Panneau gauche (en bas)</p>	<p>⑩ x 1</p>  <p>Right panel (bottom) Panneau droit (en bas)</p>
<p>⑯ x 1</p>  <p>Horizontal rail (top) Rail horizontal (haut)</p>	<p>⑳ x 2</p>  <p>Middle shelf Étagère du milieu</p>
<p>③③ x 2</p>  <p>Extra leg Jambe supplémentaire</p>	<p>④③ x 1</p>  <p>Horizontal rail (bottom) Rail horizontal (en bas)</p>
<p>④④ x 1</p>  <p>Horizontal rail (top) Rail horizontal (haut)</p>	<p>④⑥ x 1</p>  <p>Top Panel Panneau supérieur</p>
<p>⑤③ x 1</p>  <p>Shelf panel Panneau d'étagère</p>	<p>⑤④ x 1</p>  <p>Drawer Front Façade du tiroir</p>
<p>⑤⑤ x 1</p>  <p>Drawer Side Côté du tiroir</p>	<p>⑤⑥ x 1</p>  <p>Drawer Side Côté du tiroir</p>



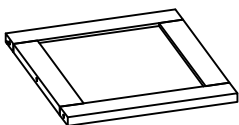
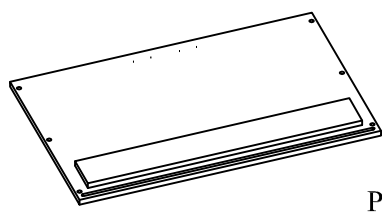

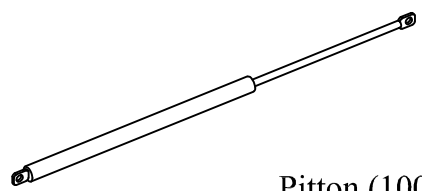
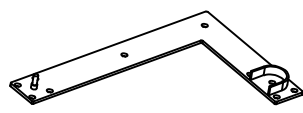
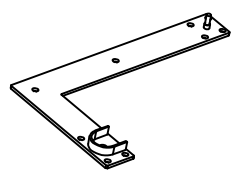
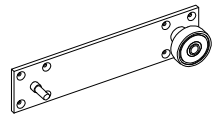





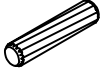



Part List & Hardware List (Box 4 - N708P392458)

Liste des pièces & Liste du matériel (boîte 4- N708P392458)

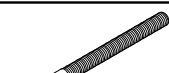
<p>⑤⑦ x 1</p>  <p>Drawer back Tiroir arrière</p>	<p>⑤⑧ x 1</p>  <p>Drawer Bottom Fond de tiroir</p>
<p>⑤⑨ x 1</p>  <p>Drawer Bottom Support Rail Rail de support inférieur du tiroir</p>	<p>⑥① x 1</p>  <p>Crossbar Barre transversale</p>
<p>⑥② x 1</p>  <p>Crossbar Barre transversale</p>	<p>⑥③ x 4</p>  <p>Shelf panel Panneau d'étagère</p>
<p>⑥④ x 1</p>  <p>Top panel Panneau supérieur</p>	<p>⑥⑤ x 1</p>  <p>Bottom panel Panneau inférieur</p>
<p>⑦② x 2</p>  <p>Pitton (1000N) - 2pcs Pitton (1000N)</p>	<p>⑦③ x 1</p>  <p>Bracket L (left) Support L (gauche)</p>
<p>⑦④ x 1</p>  <p>Bracket L (right) Support L (droit)</p>	<p>⑦⑤ x 2</p>  <p>Bracket Support</p>

Hardware List (Box 4 - N708P392458)

Liste du matériel (Box 4 - N708P392458)











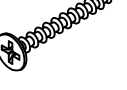
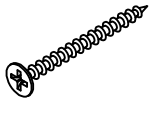
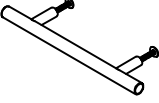

No.	OUTLOOK	DESC	QTY
(A)		Dowel Ø10*40mm Cheville	22
(B)		Bolts 1/4"*20mm Boulons	08
(C)		Bolts 1/4"*25mm Boulons	52
(D)		Bolts 1/4"*35mm Boulons	02
(E)		Bolts 5/16"*40mm Boulons	02
(F)		Bolts 1/4"*60mm Boulons	18
(G)		Bolts 1/4"*70mm Boulons	14
(H)		Bolts 1/4"*80mm Boulons	14
(I)		Bolts 1/4"*100mm Boulons	28
(J)		Bolts 1/4"*120mm Boulons	14
(K)		Cross dowel 1/4"*13mm Cheville croisée	88
(L)		Hex bolts 1/4"*15mm Boulons hexagonaux	13
(M)		Round head screw #7*15mm Vis à tête ronde	12
(N)		Round head screw #7*25mm Vis à tête ronde	15
(O)		Screws #6*12mm Des vis	14

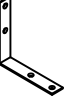
ASSEMBLY TOOLS REQUIRED (NOT INCLUDED)/OUTILS D'ASSEMBLAGE REQUIS (NON INCLUS)



Hardware List (Box 4 - N708P392458)

Liste du matériel (Box 4 - N708P392458)

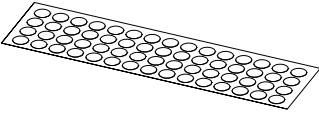

No.	OUTLOOK	DESC	QTY
(P)		Screws #6*15mm Des vis	60
(Q)		Screws #8*20mm Des vis	52
(R)		Screws #8*30mm Des vis	65
(S)		Screws #8*40mm Des vis	04
(T)		Handle Poignée	11
(U)		Door closer Ferme-porte	06
(V)		Patt L Tapoter	04
(W)		Base L Drawer Socle L	01
(X)		Door Hinge Charnière de porte	12
(Y)		Connecting Bolt Boulon de connexion	16
(Z)		Plastic stopper Bouchon en plastique	16
(AA)		Insert nut Insérer l'écrou	04
(AB)		Wrench key (K13) Clé à molette	01
(AC)		Allen key 60*22*4mm clé Allen	02
(AD)		Cover Sticker Autocollant de couverture	70

ASSEMBLY TOOLS REQUIRED (NOT INCLUDED)/OUTILS D'ASSEMBLAGE REQUIS (NON INCLUS)



Hardware List (Box 4 - N708P392458)

Liste du matériel (Box 4 - N708P392458)

No.	OUTLOOK	DESC	QTY
AE		Wood support Support en bois	02
AF		Bolts 1/4"*30mm Boulons	03
AG		Patt L Tapoter	04
AH		Door latch Loquet de porte	02
AI		Screws #8*50mm Des vis	16

ASSEMBLY TOOLS REQUIRED (NOT INCLUDED)/OUTILS D'ASSEMBLAGE REQUIS (NON INCLUS)

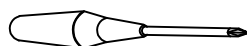

STEP 1

Étape
SCAN ME
SCANEZ-MOI



Assembly Video
Vidéo d'assemblage

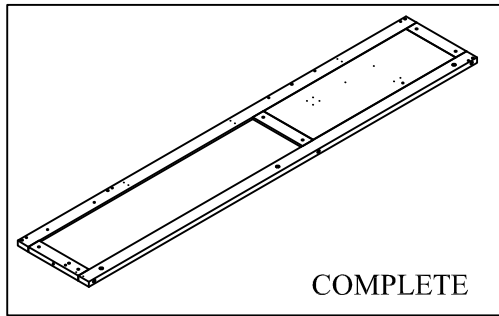

(I)		06
(K)		06

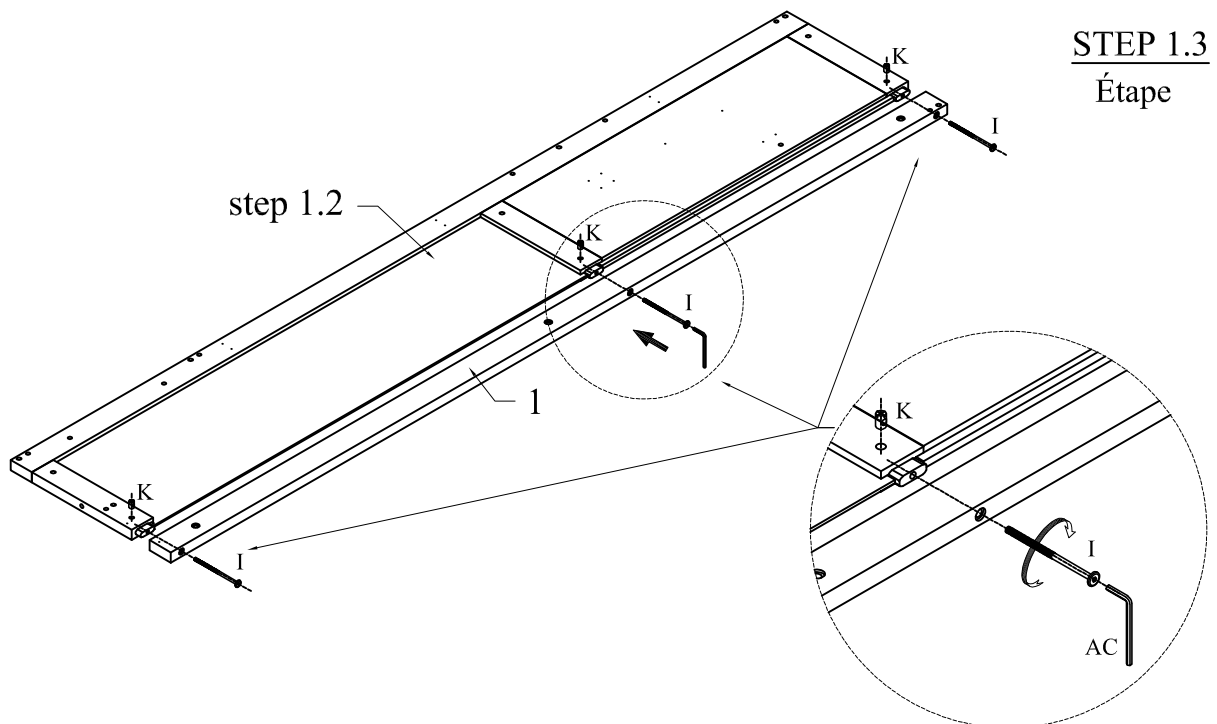
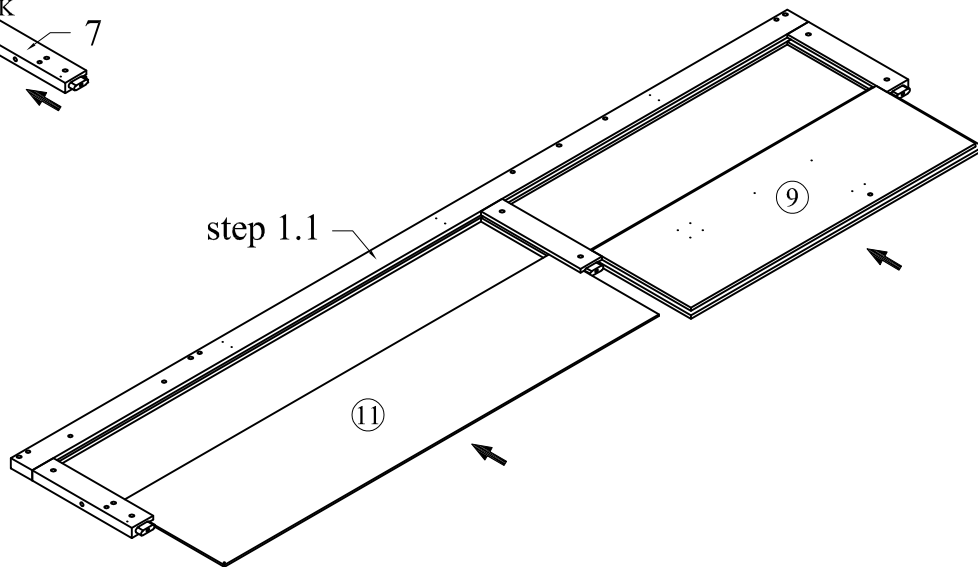
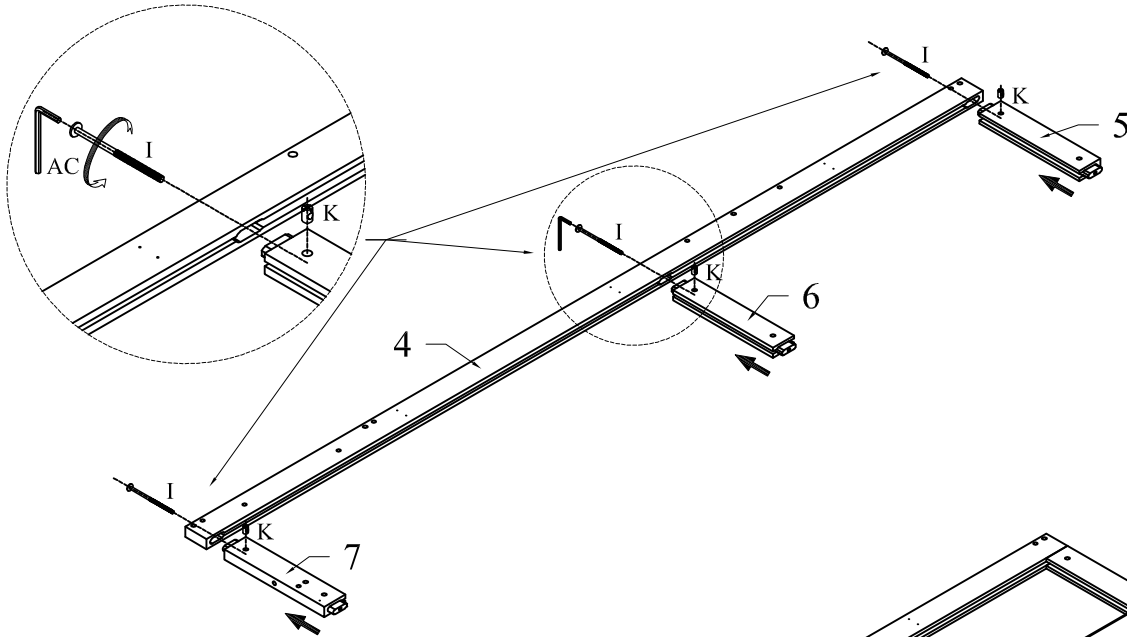

STEP 2

Étape
SCAN ME
SCANEZ-MOI



Assembly Video
Vidéo d'assemblage

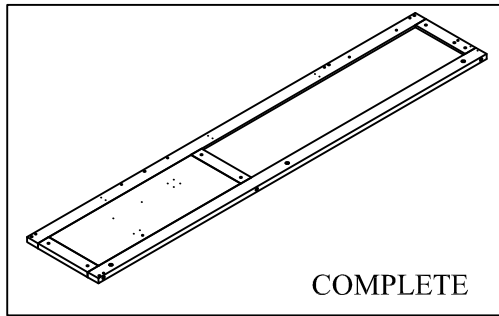

(I)		06
(K)		06

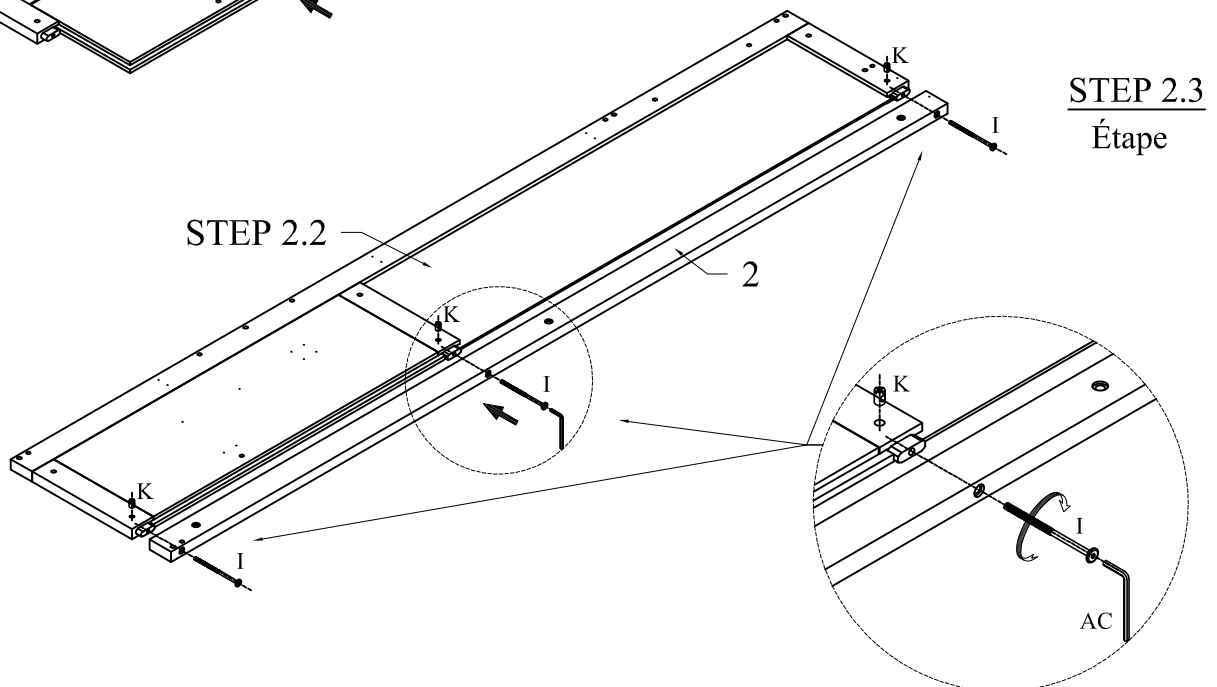
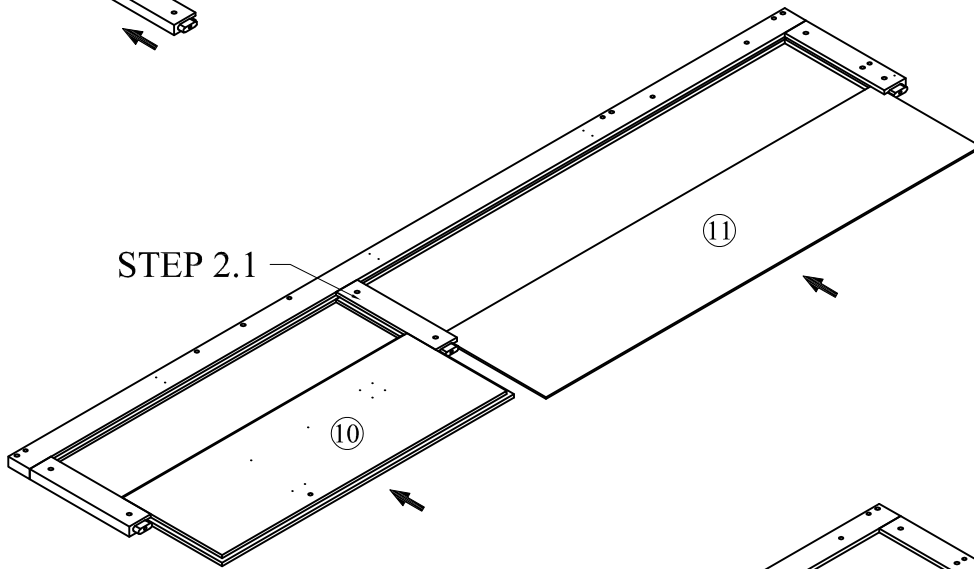
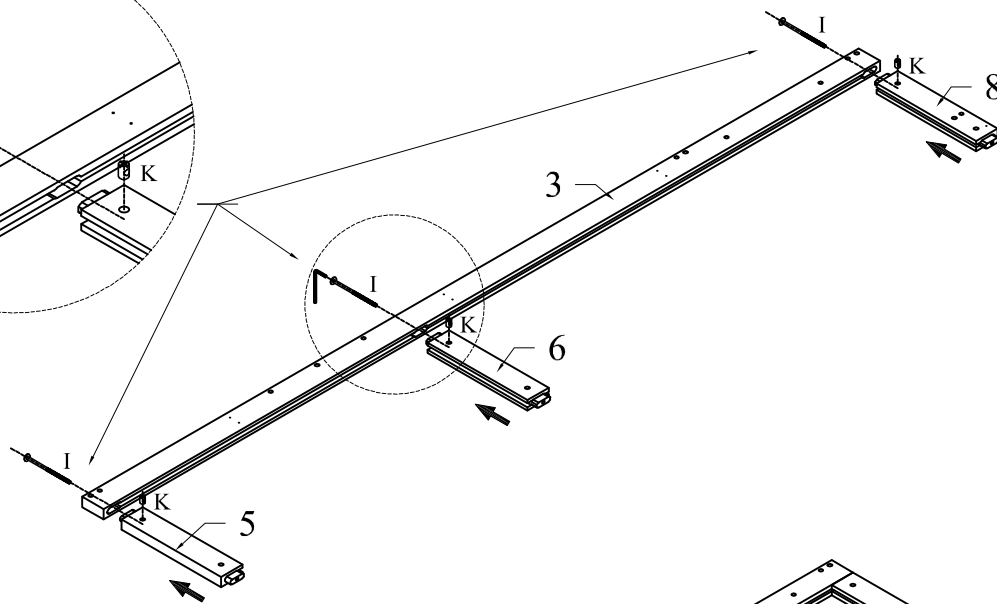
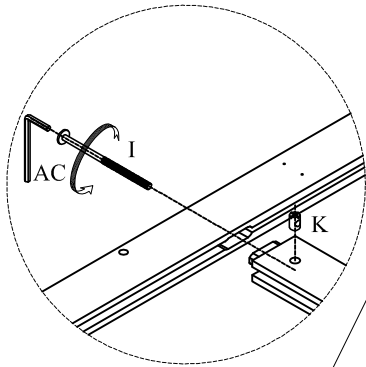

STEP 3

Étape
SCAN ME
SCANEZ-MOI



Assembly Video
Vidéo d'assemblage

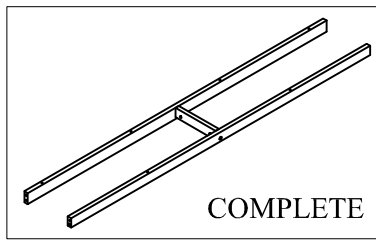

(A)		02
(F)		02
(K)		02

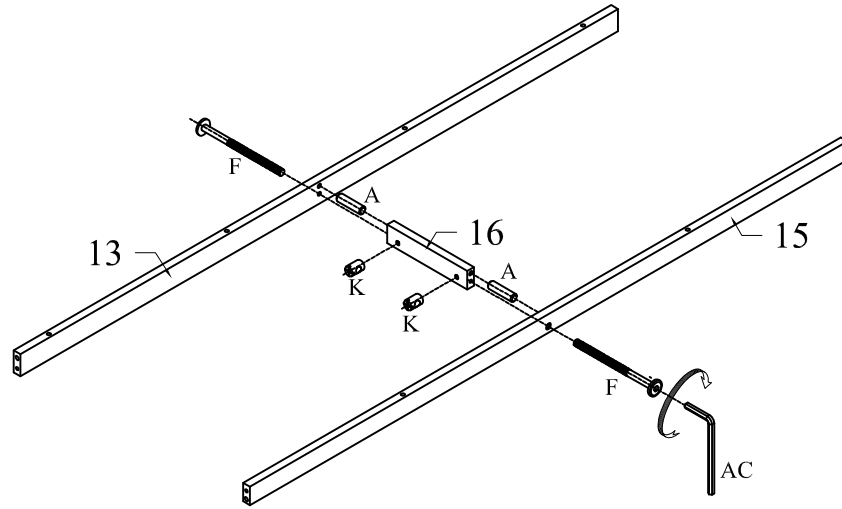

STEP 4

Étape
SCAN ME
SCANEZ-MOI



Assembly Video
Vidéo d'assemblage

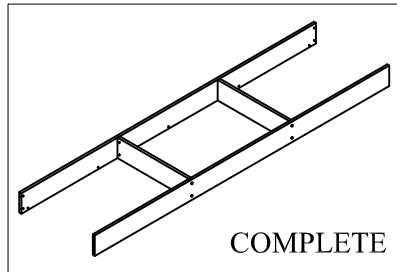

(R)		08
-----	--	----

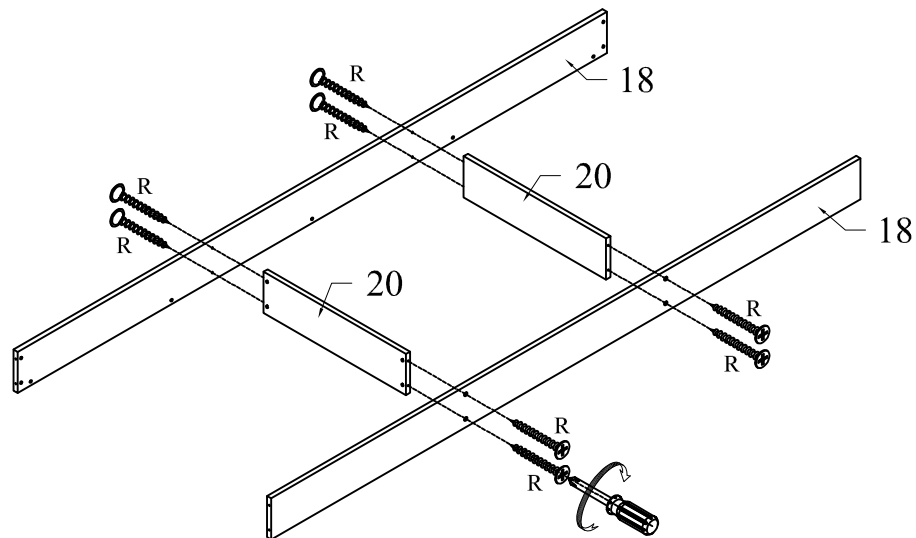

STEP 5

Étape
SCAN ME
SCANEZ-MOI



Assembly Video
Vidéo d'assemblage

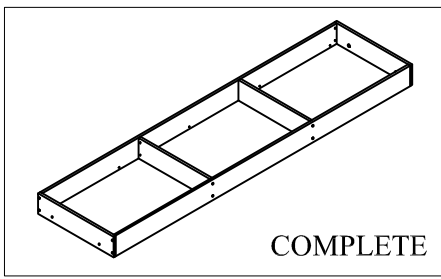

(R)		08
-----	--	----

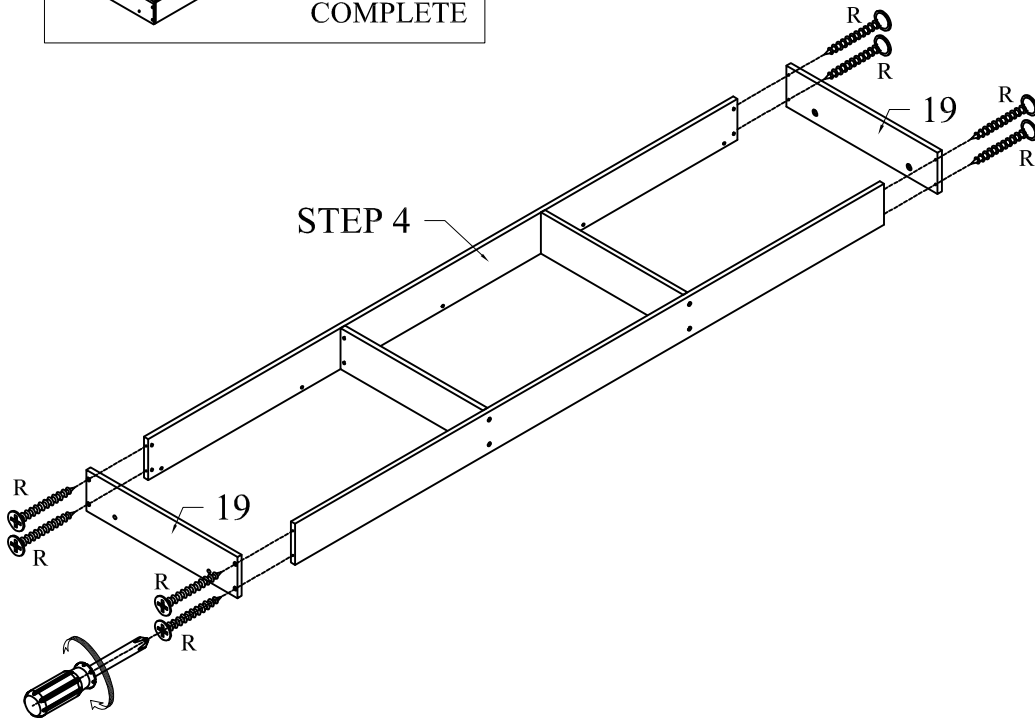

STEP 6

Étape
SCAN ME
SCANEZ-MOI



Assembly Video
Vidéo d'assemblage

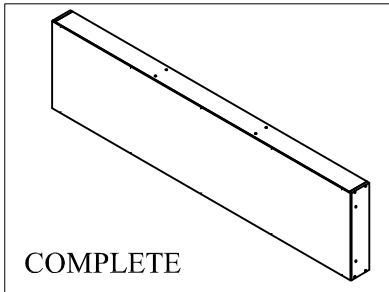

(N)		10
-----	--	----

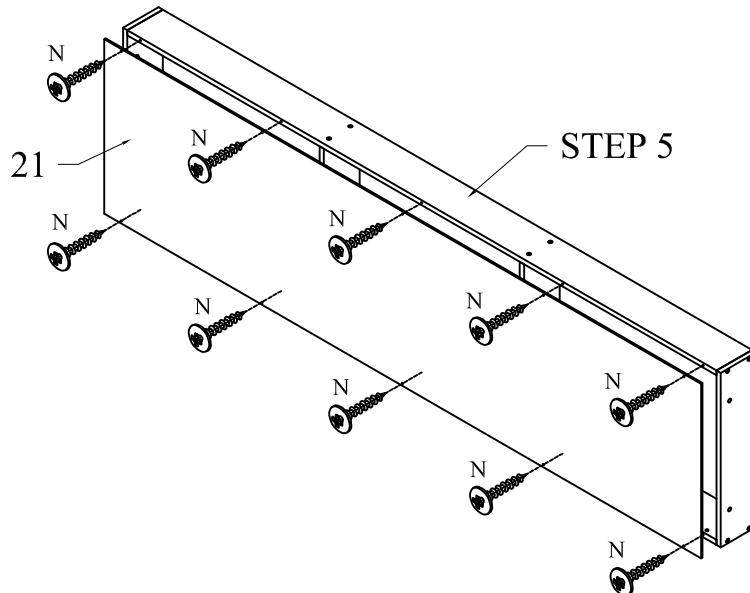

STEP 8

Étape

SCAN ME
SCANEZ-MOI



Assembly Video
Vidéo d'assemblage

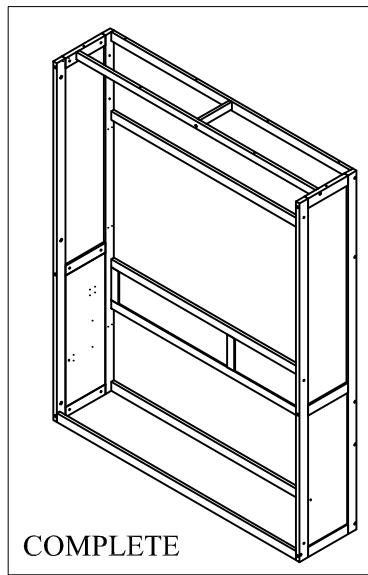

(A)		06
(G)		07
(K)		07

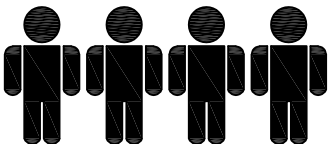
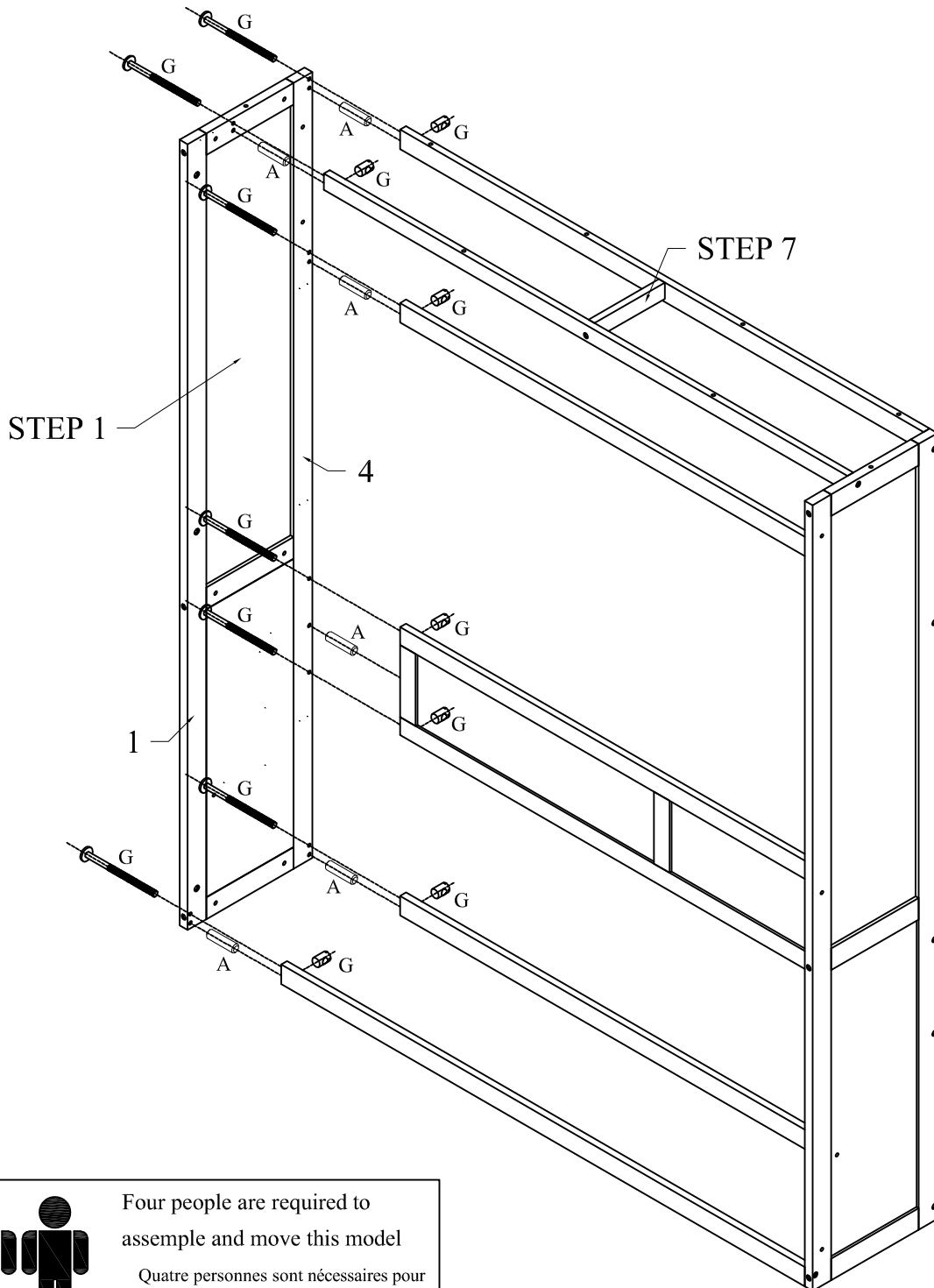

Four people are required to
assemble and move this model

Quatre personnes sont nécessaires pour
assembler et déplacer ce modèle

STEP 9

Étape

SCAN ME
SCANEZ-MOI



Assembly Video
Vidéo d'assemblage

©		04
---	--	----

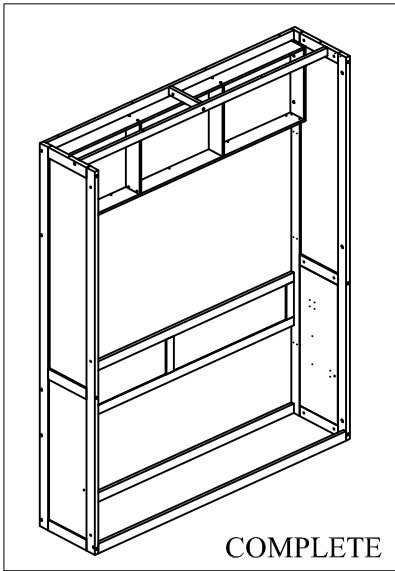

STEP 8

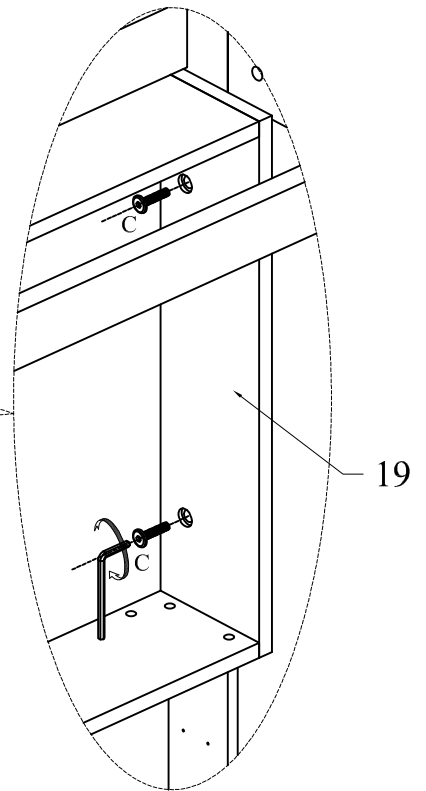
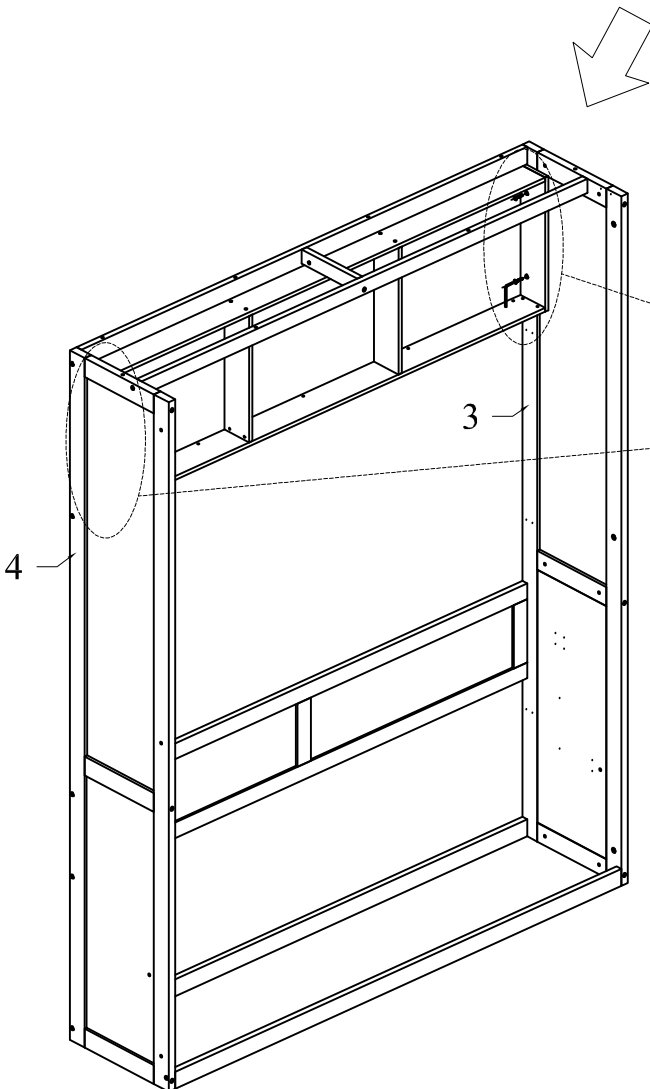
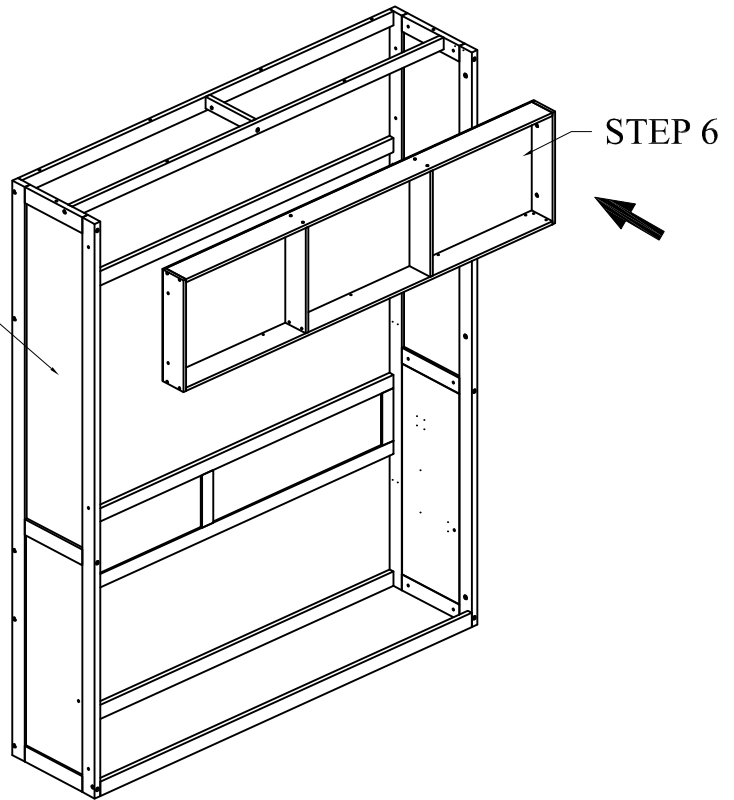

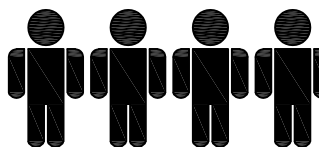
	<p>Four people are required to assemble and move this model</p> <p>Quatre personnes sont nécessaires pour assembler et déplacer ce modèle</p>
--	---

STEP 10

Étape

SCAN ME
SCANEZ-MOI



Assembly Video
Vidéo d'assemblage

©		08
---	--	----

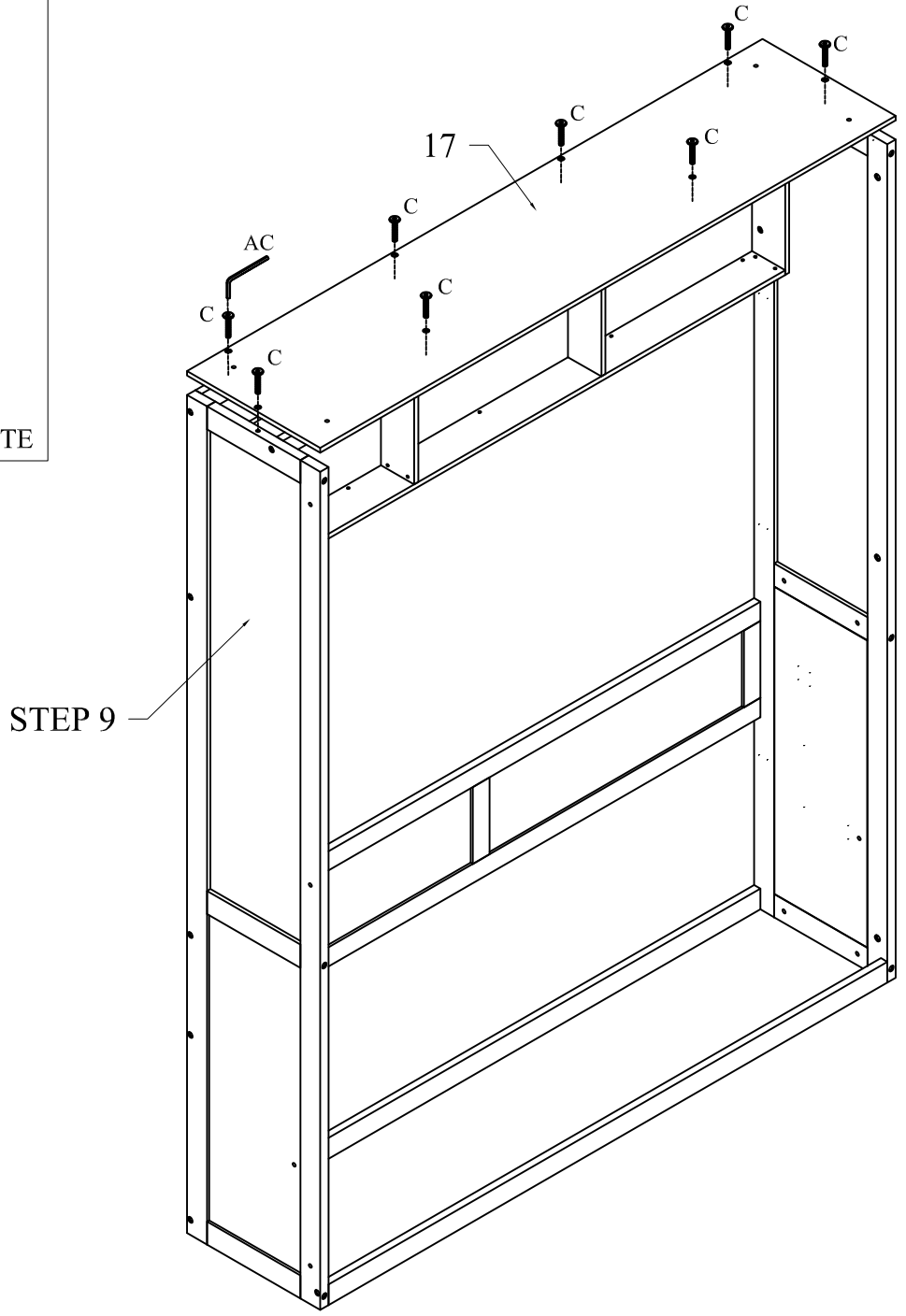
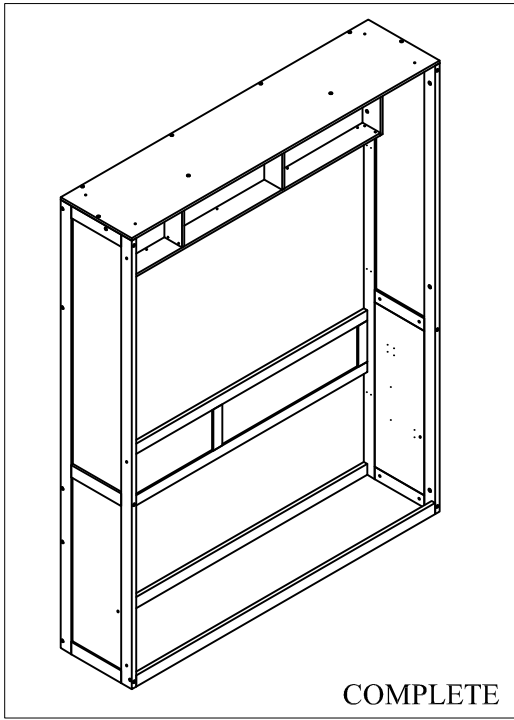

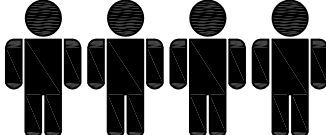
	<p>Four people are required to assemble and move this model</p> <p>Quatre personnes sont nécessaires pour assembler et déplacer ce modèle</p>
---	---

STEP 11

Étape

SCAN ME
SCANEZ-MOI



Assembly Video
Vidéo d'assemblage



10

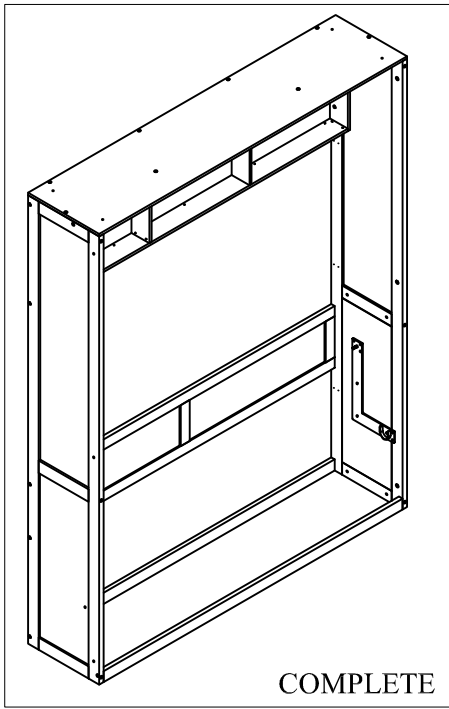

COMPLETE

STEP 10

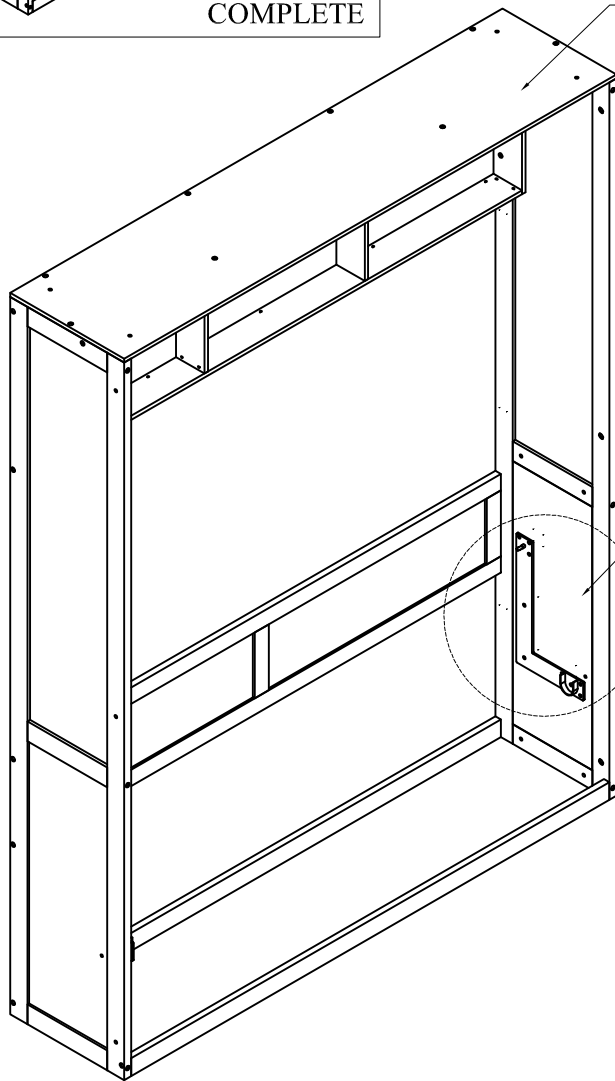

10

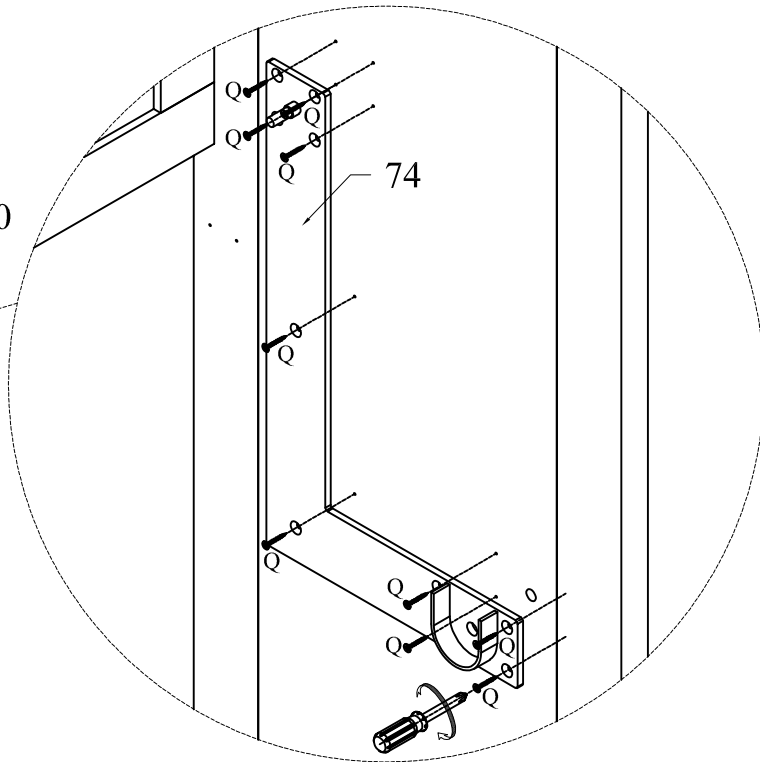

74

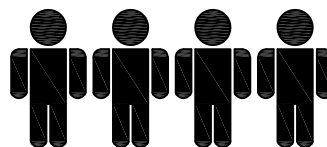

Four people are required to
assemble and move this model

Quatre personnes sont nécessaires pour
assembler et déplacer ce modèle

STEP 12

Étape

SCAN ME
SCANEZ-MOI



Assembly Video
Vidéo d'assemblage



10

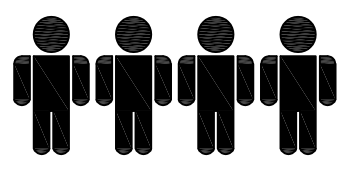
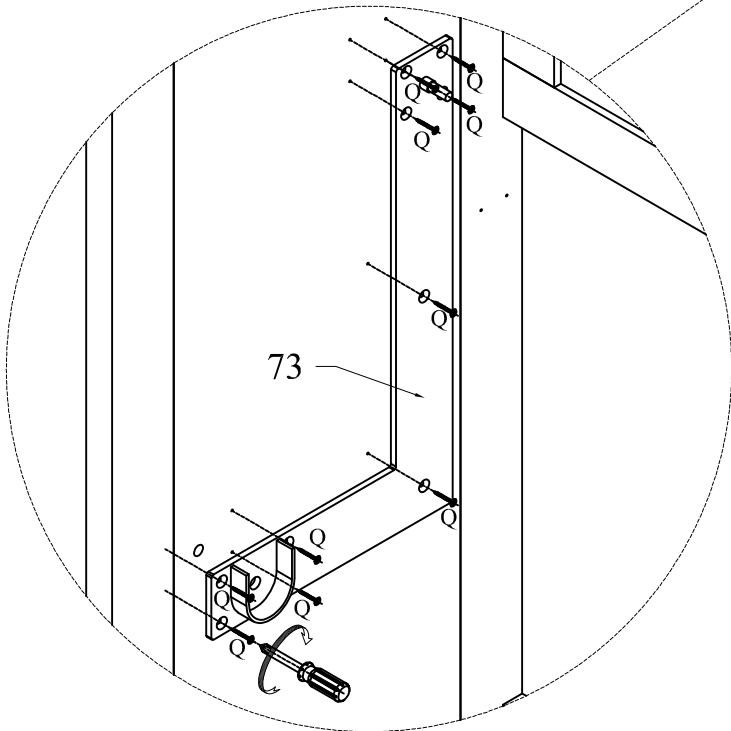
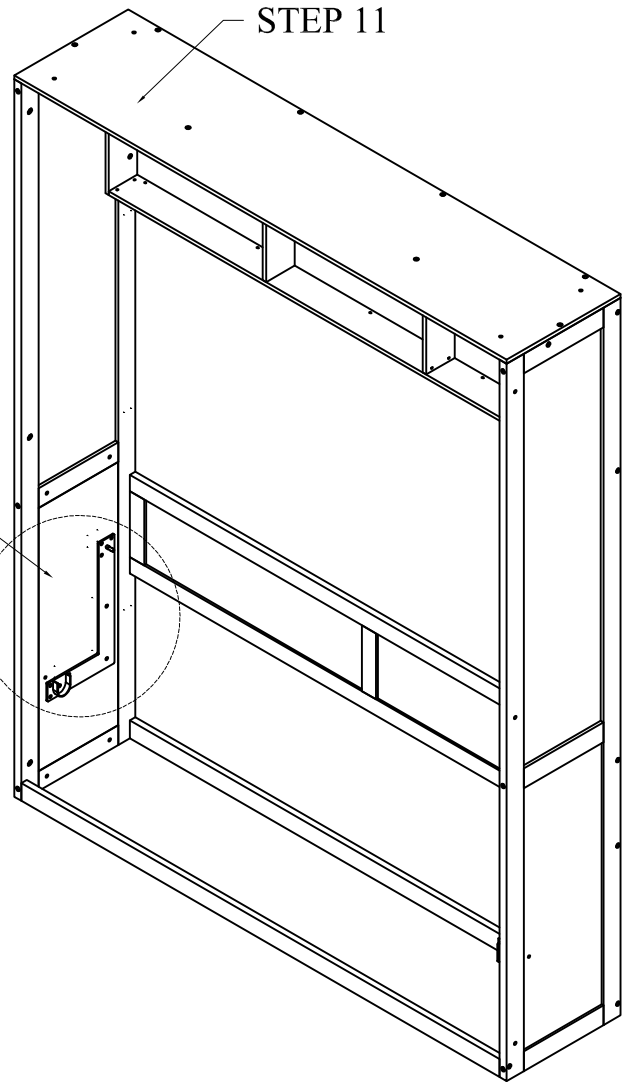
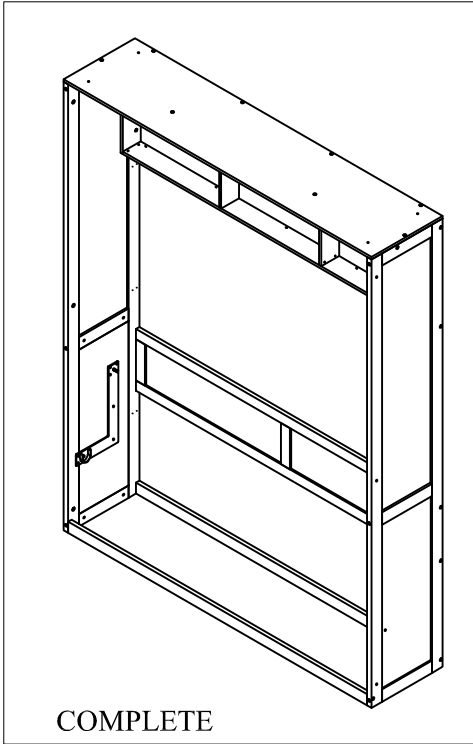

Four people are required to assemble and move this model

Quatre personnes sont nécessaires pour assembler et déplacer ce modèle



STEP 13

Étape

SCAN ME
SCANEZ-MOI



Assembly Video
Vidéo d'assemblage

(A)		04
(F)		08
(K)		08

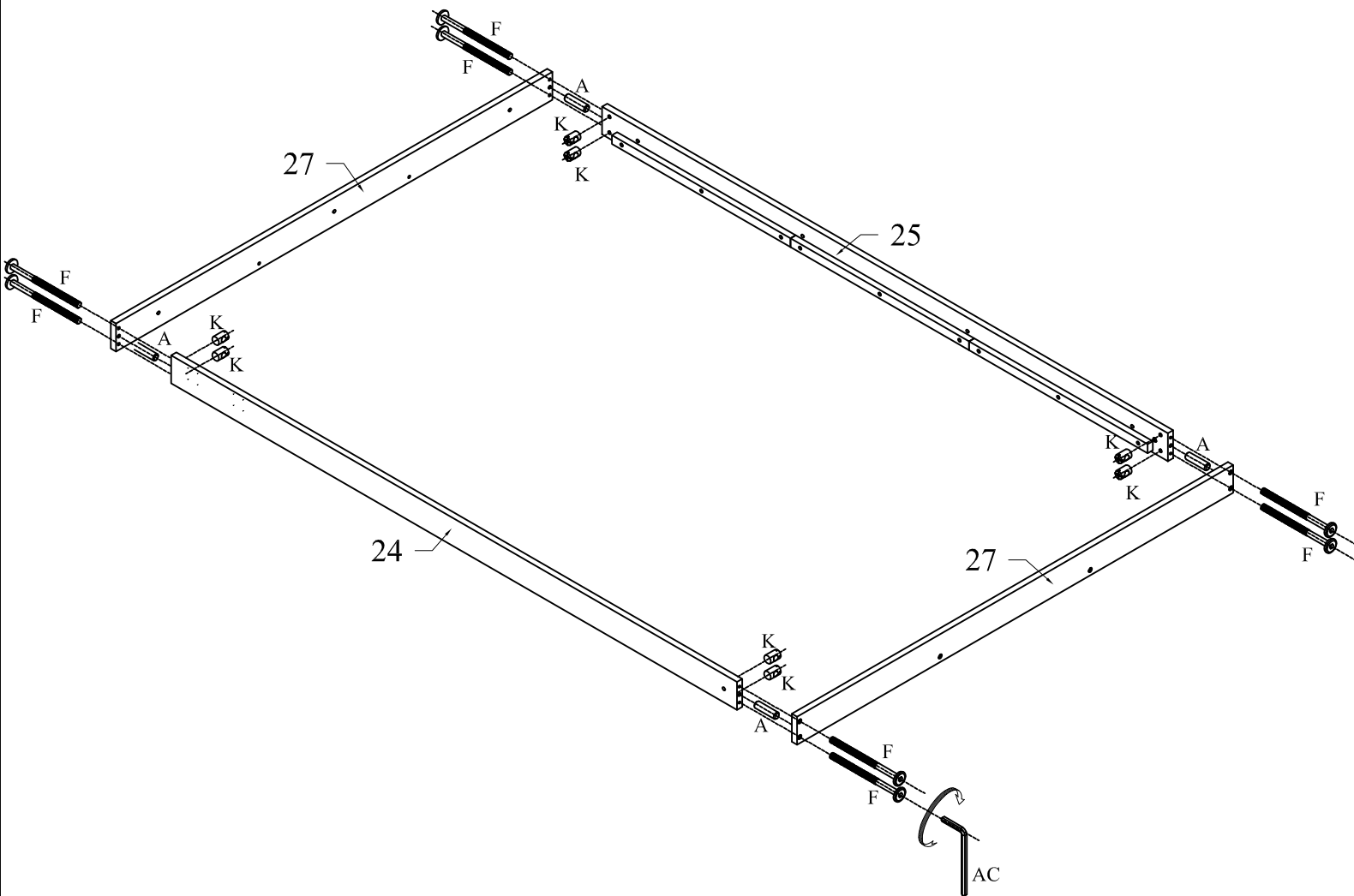
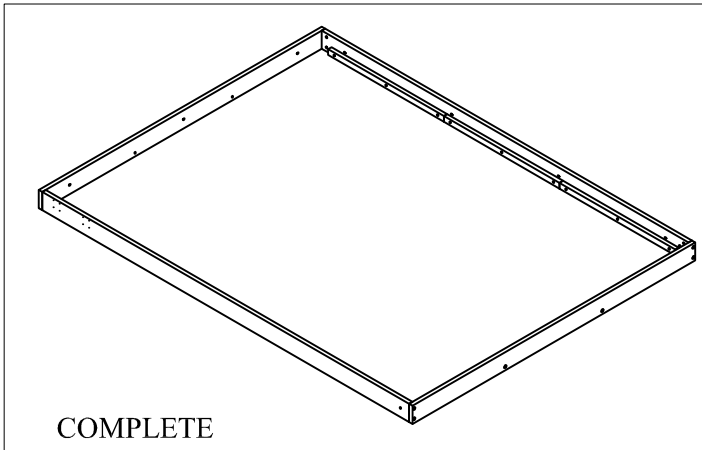

STEP 14

Étape

SCAN ME
SCANEZ-MOI



Assembly Video
Vidéo d'assemblage

(J)		08
(K)		08

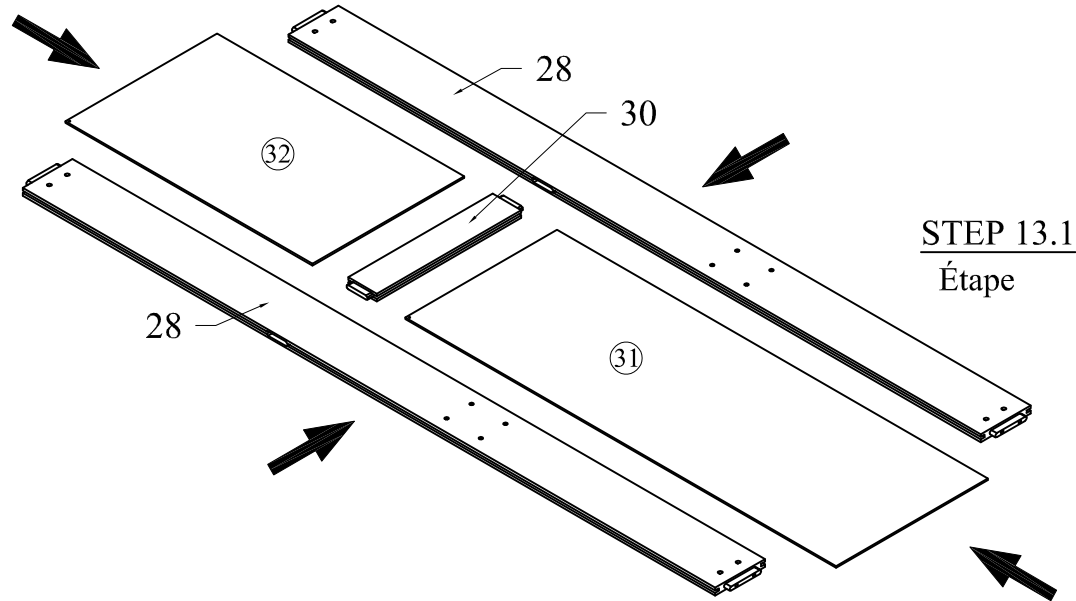
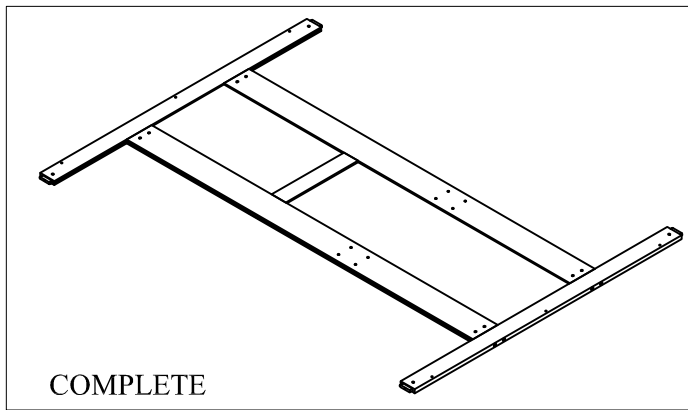

STEP 13.1
Étape

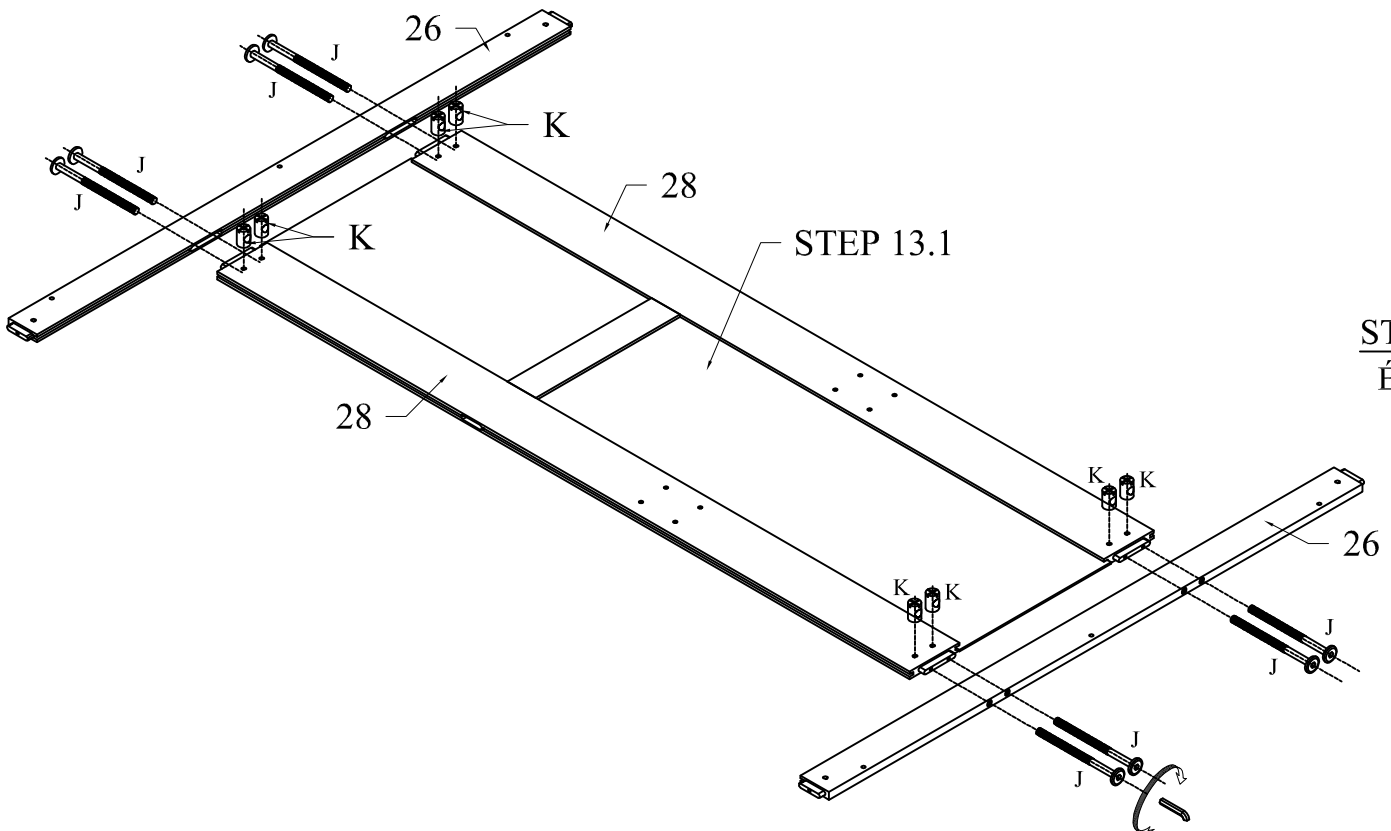

STEP 13.2
Étape



STEP 15

Étape

SCAN ME
SCANEZ-MOI

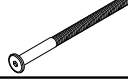

Assembly Video
Vidéo d'assemblage

(J)		06
(K)		06

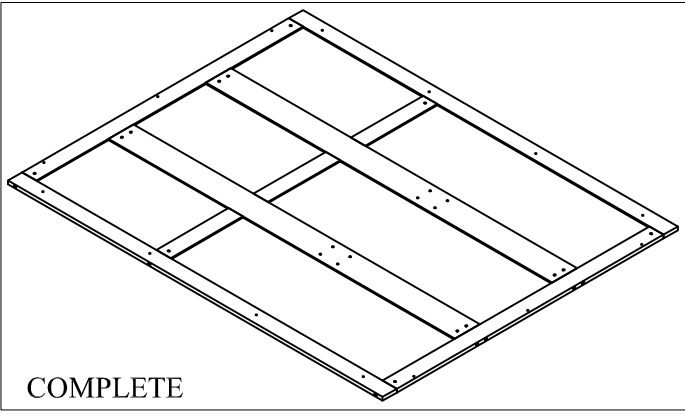

COMPLETE

The part has a warning label on the underside

La pièce comporte une étiquette d'avertissement sur le dessous.

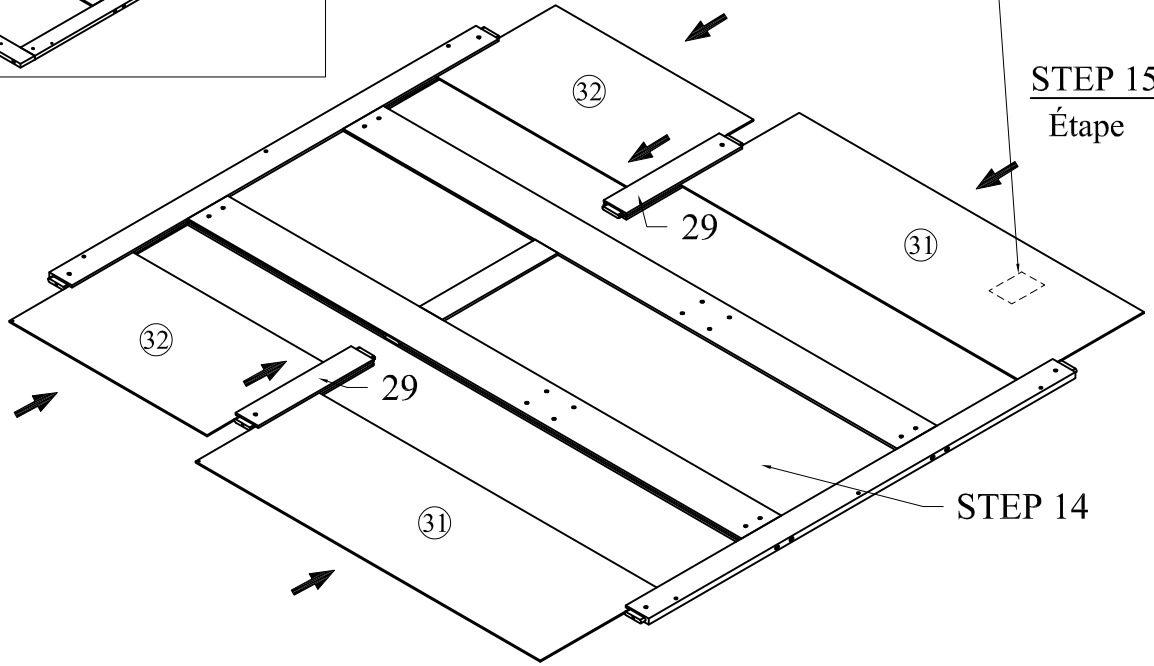

STEP 15.1

Étape

STEP 14



STEP 15.2

Étape

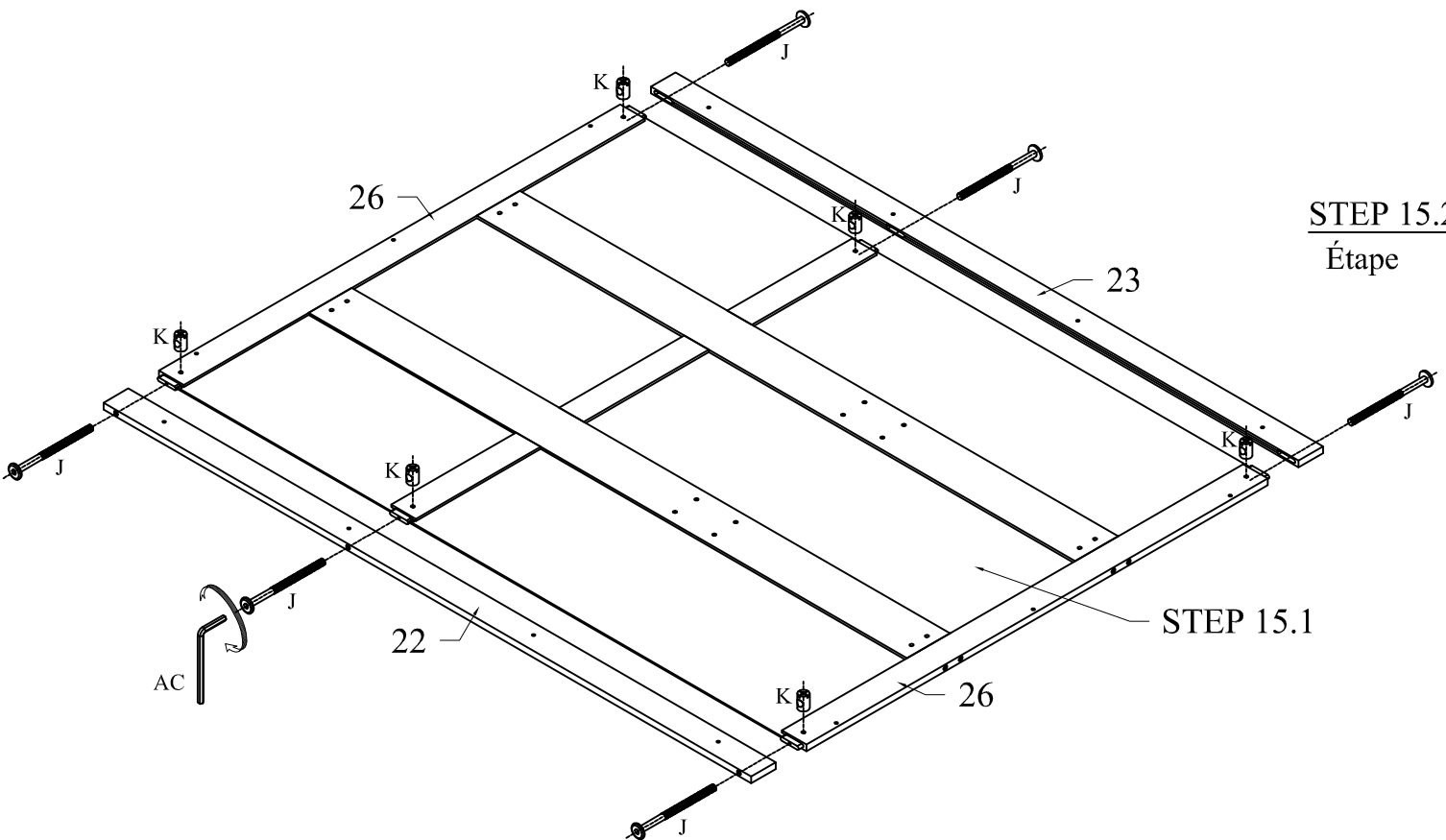

STEP 15.1



STEP 16

Étape

SCAN ME
SCANEZ-MOI



Assembly Video
Vidéo d'assemblage

(H)		14
(K)		14

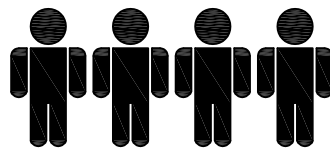
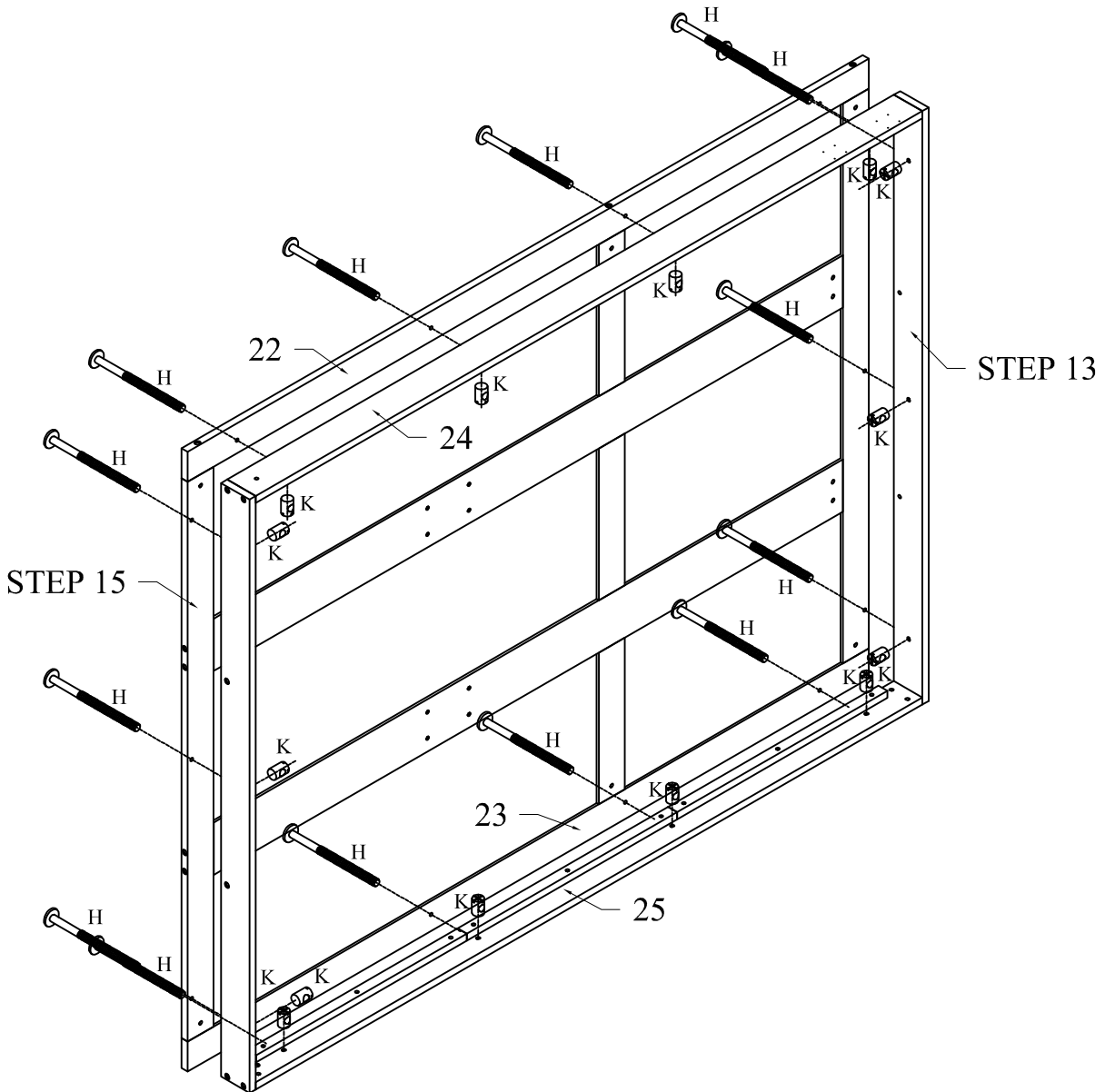
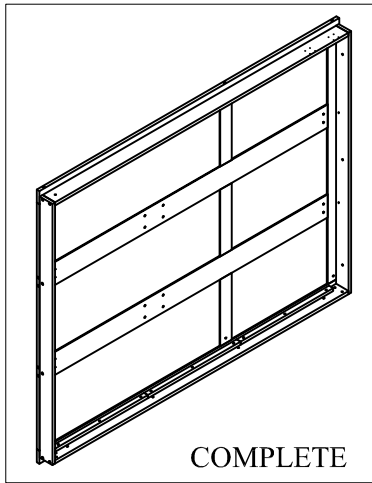

Four people are required to
assemble and move this model

Quatre personnes sont nécessaires pour
assembler et déplacer ce modèle

STEP 17

Étape

SCAN ME
SCANEZ-MOI



Assembly Video
Vidéo d'assemblage

(F)		04
(K)		04
(S)		04

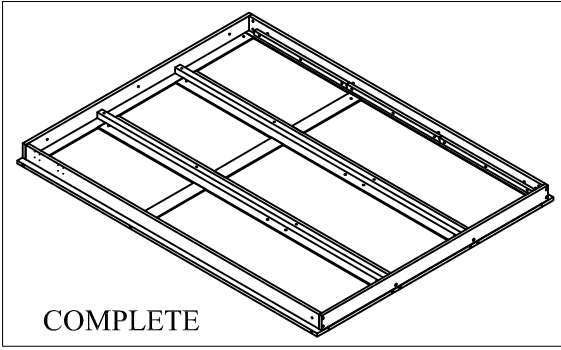

COMPLETE

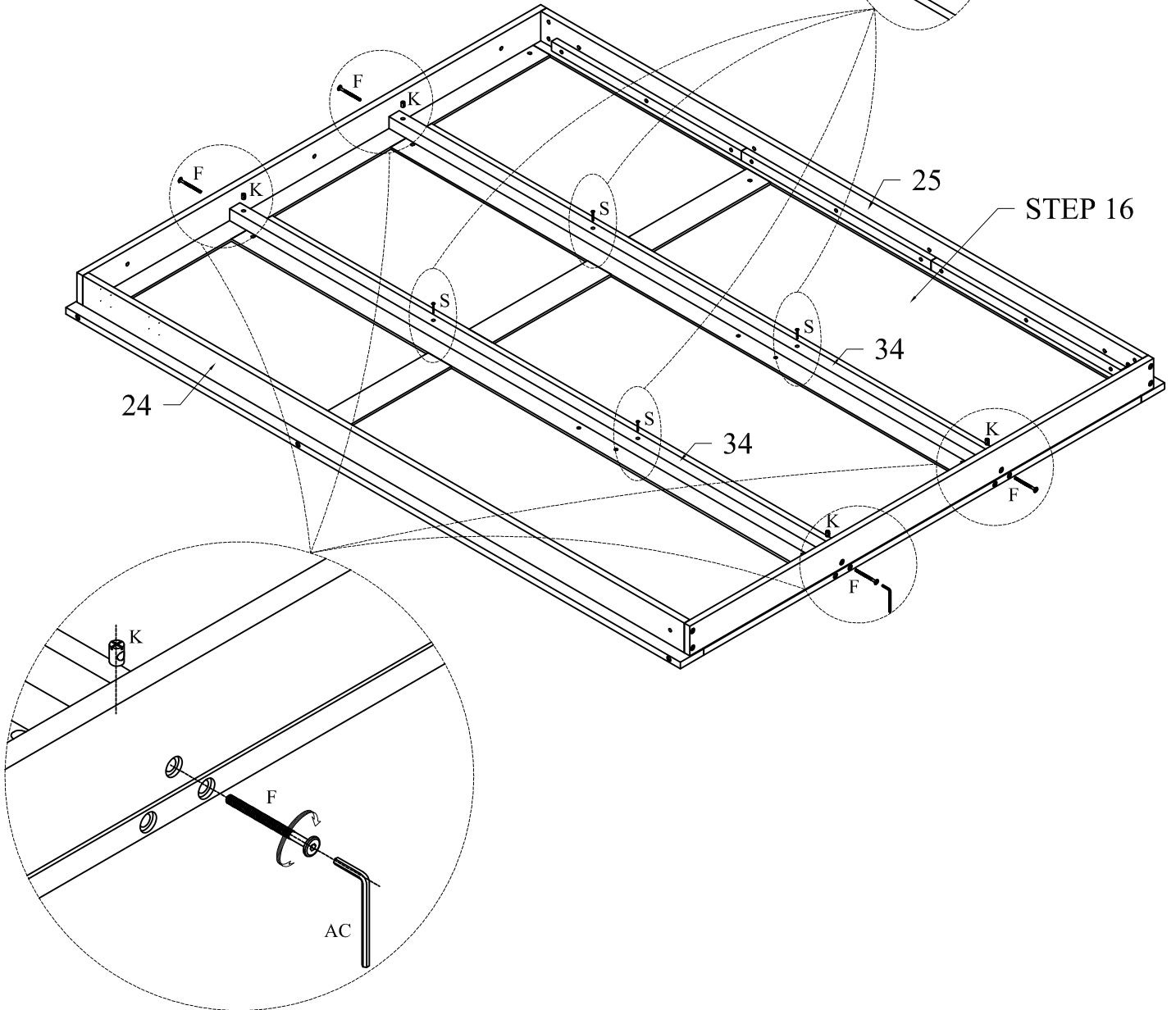
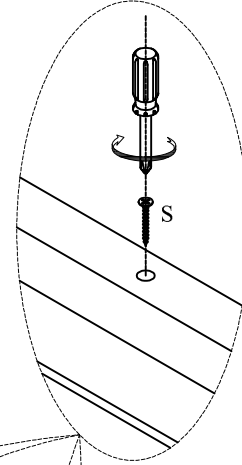

STEP 18

Étape

SCAN ME
SCANEZ-MOI



Assembly Video
Vidéo d'assemblage

Q		16
---	--	----

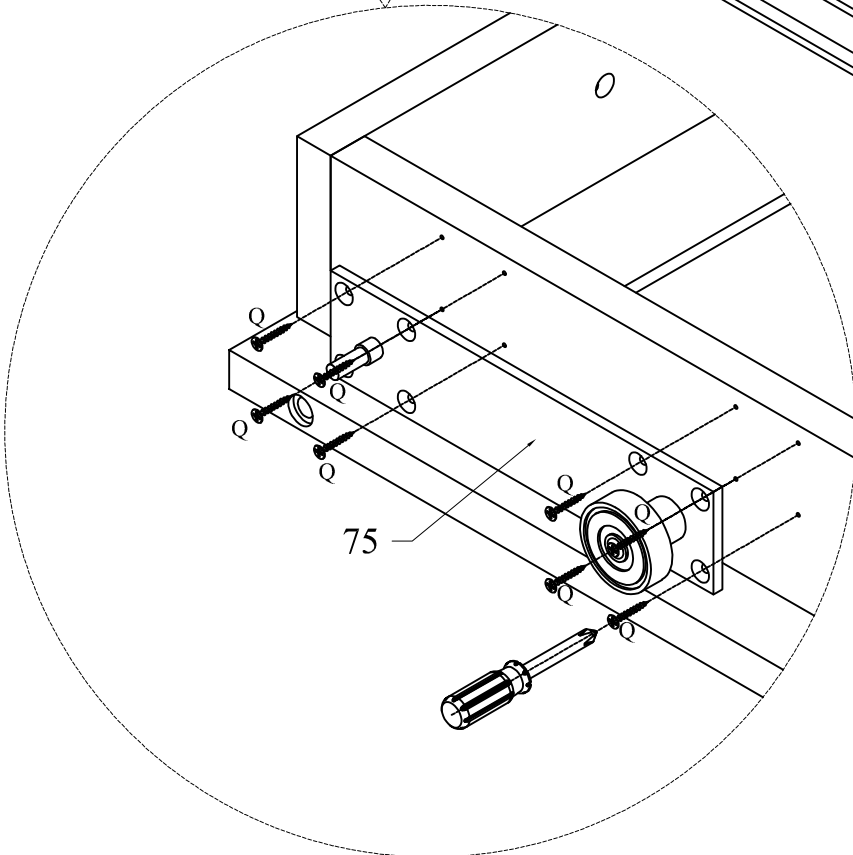
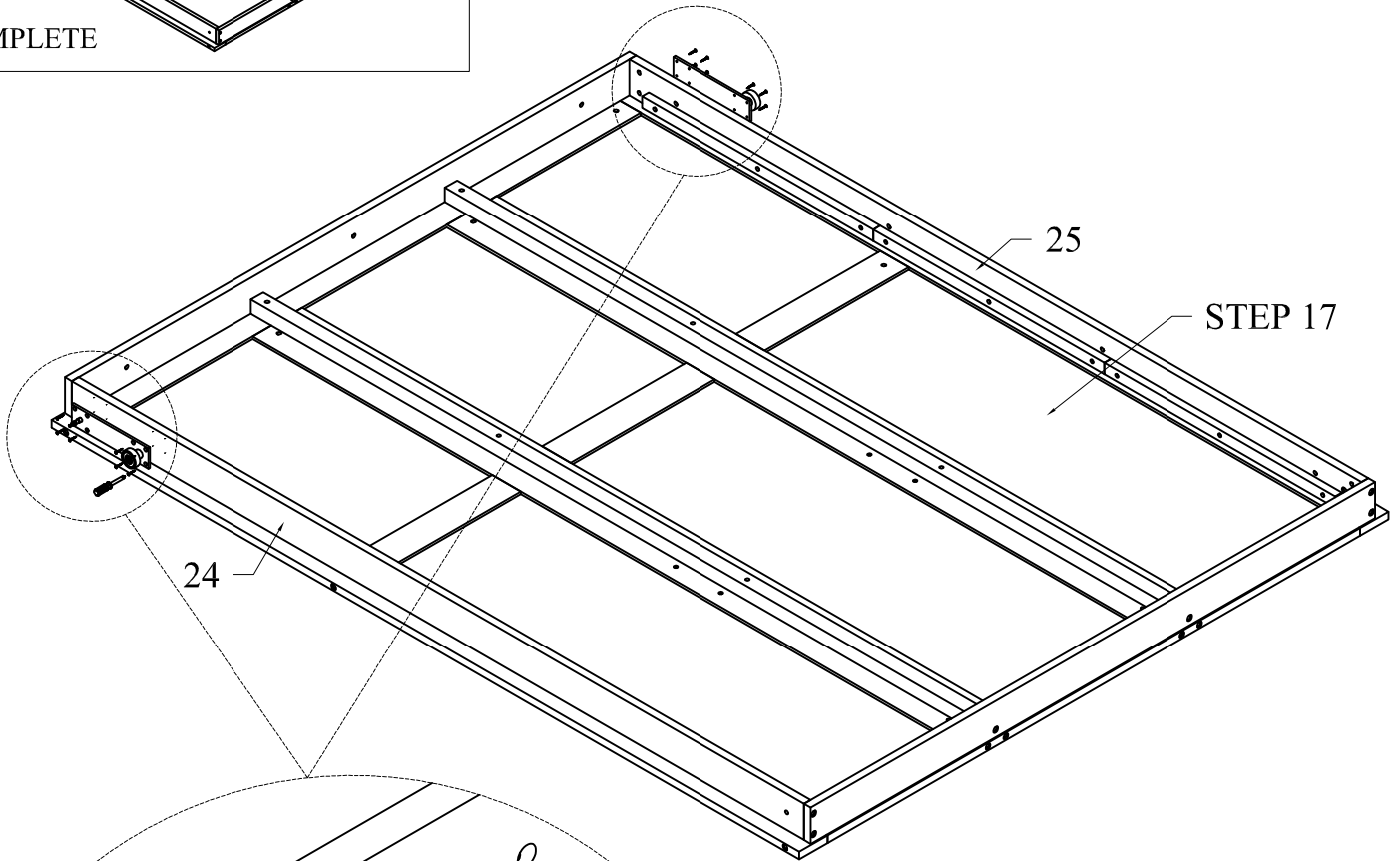
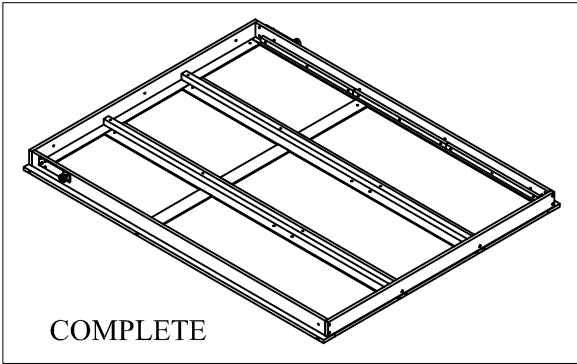



STEP 19

Étape

SCAN ME
SCANEZ-MOI



Assembly Video
Vidéo d'assemblage

AA		02
AB		01

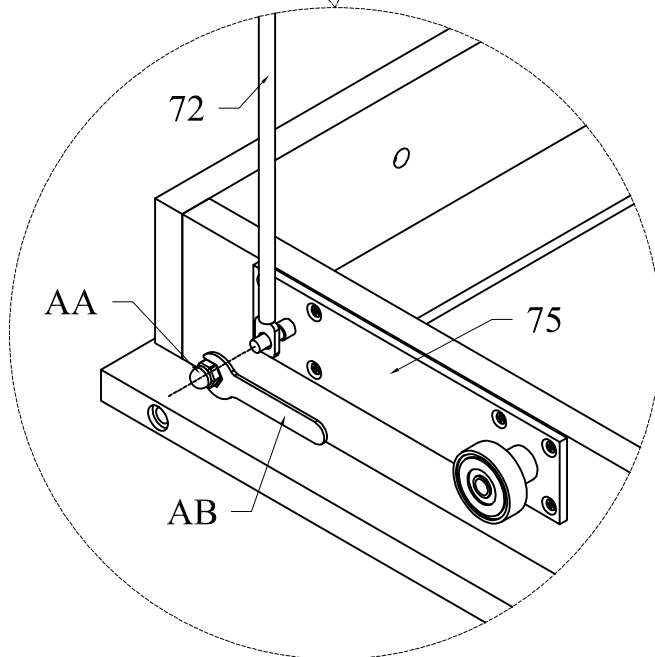
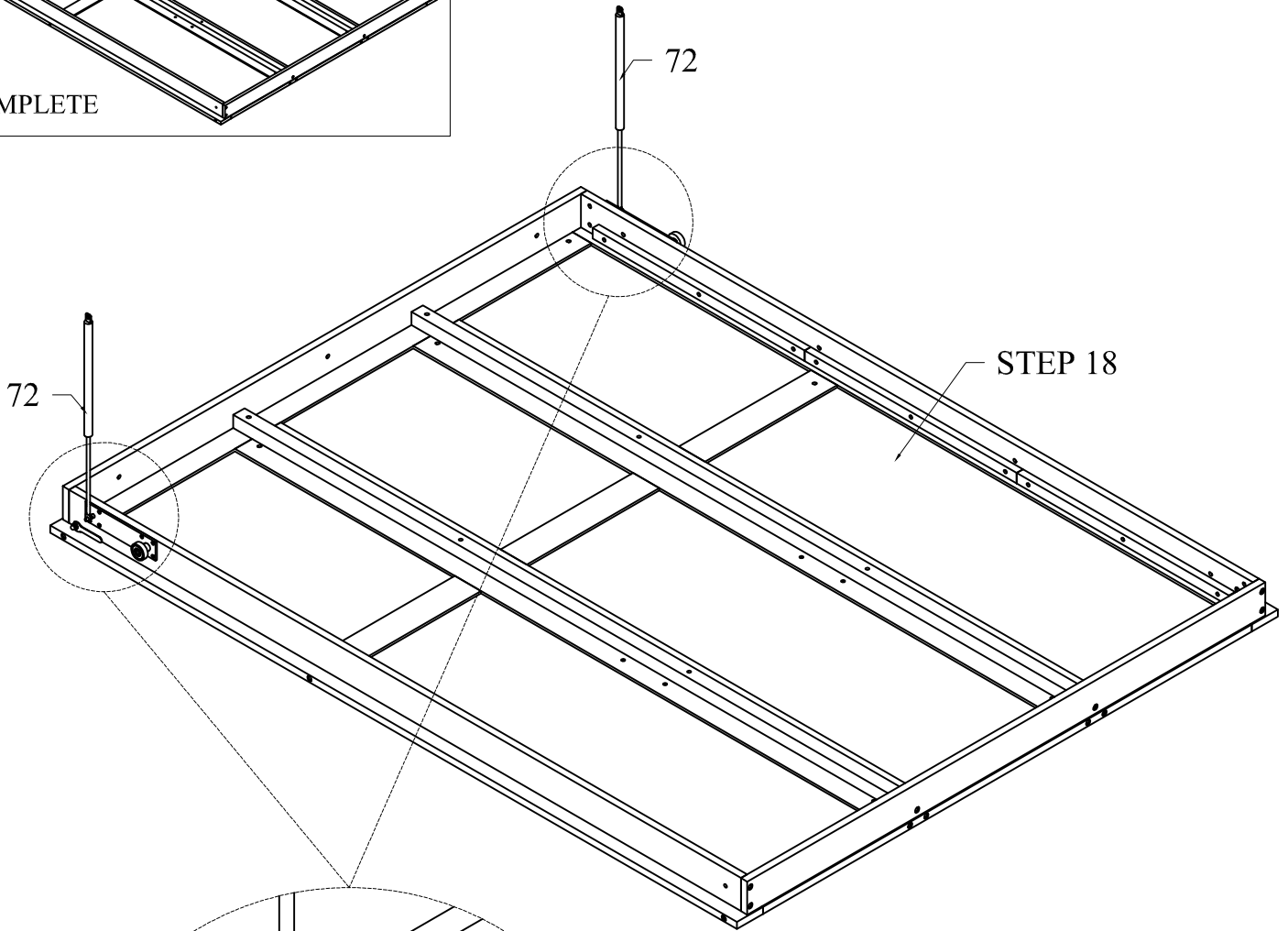
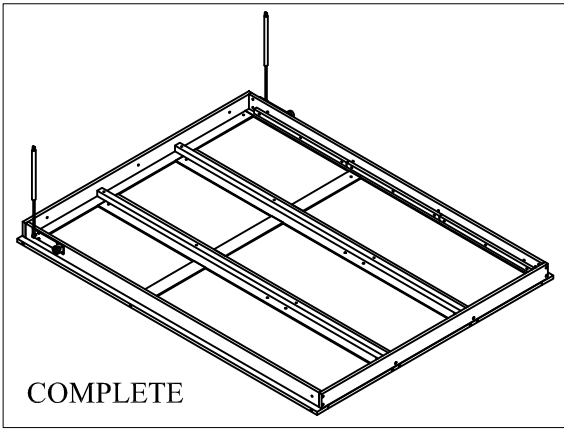

STEP 20

Étape

SCAN ME
SCANEZ-MOI



Assembly Video
Vidéo d'assemblage

E		02
---	--	----

*Transfer the completed components from step 19 to the support section on parts 73 and 74, which were assembled in step 12.

*Transférez les composants terminés de l'étape 19 vers la section de support sur les pièces 73 et 74, qui ont été assemblées à l'étape 12.

*Use hardware E to attach from the outside, securing the two parts firmly together. Make sure the gap between the bearing (part 75) and the inner sides of the bearing supports (parts 73–74) is evenly maintained at 4 mm on each side. Note that this step is very important to ensure the two parts remain securely connected during use.

*Utilisez la quincaillerie E pour fixer depuis l'extérieur et solidariser fermement les deux pièces. Assurez-vous que l'espace entre le palier (pièce 75) et les faces internes des supports de palier (pièces 73–74) soit maintenu uniformément à 4 mm de chaque côté. Notez que cette étape est très importante pour garantir que les deux pièces restent solidement reliées pendant l'utilisation.

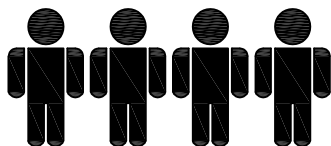
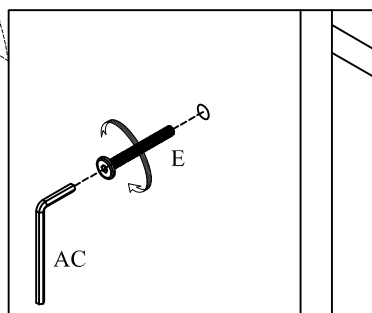
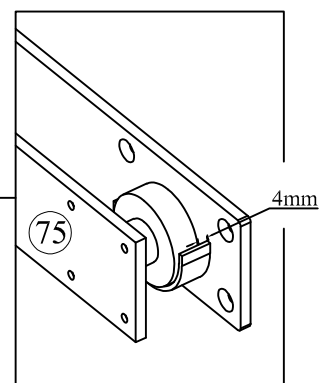
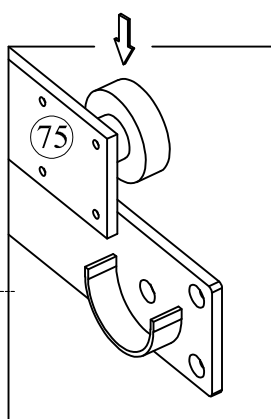
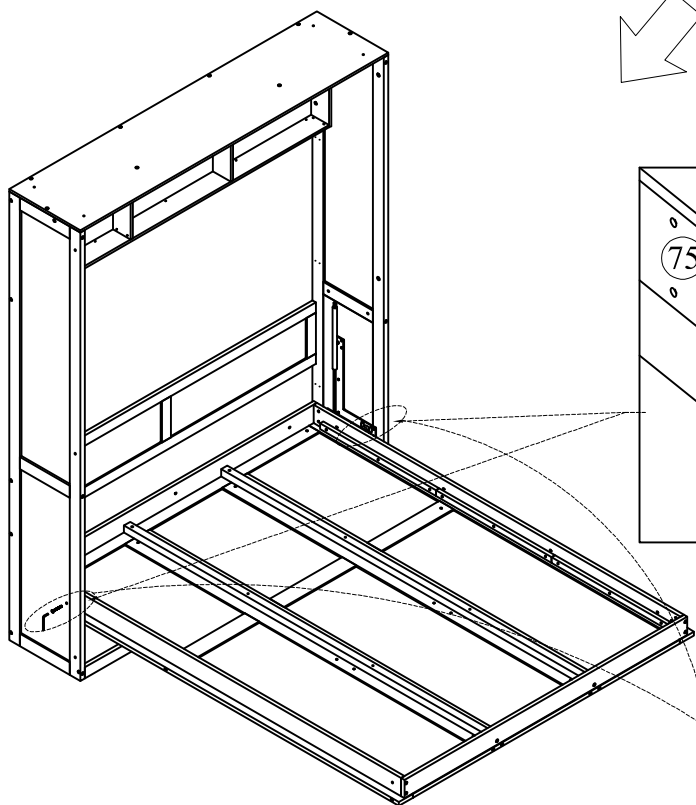
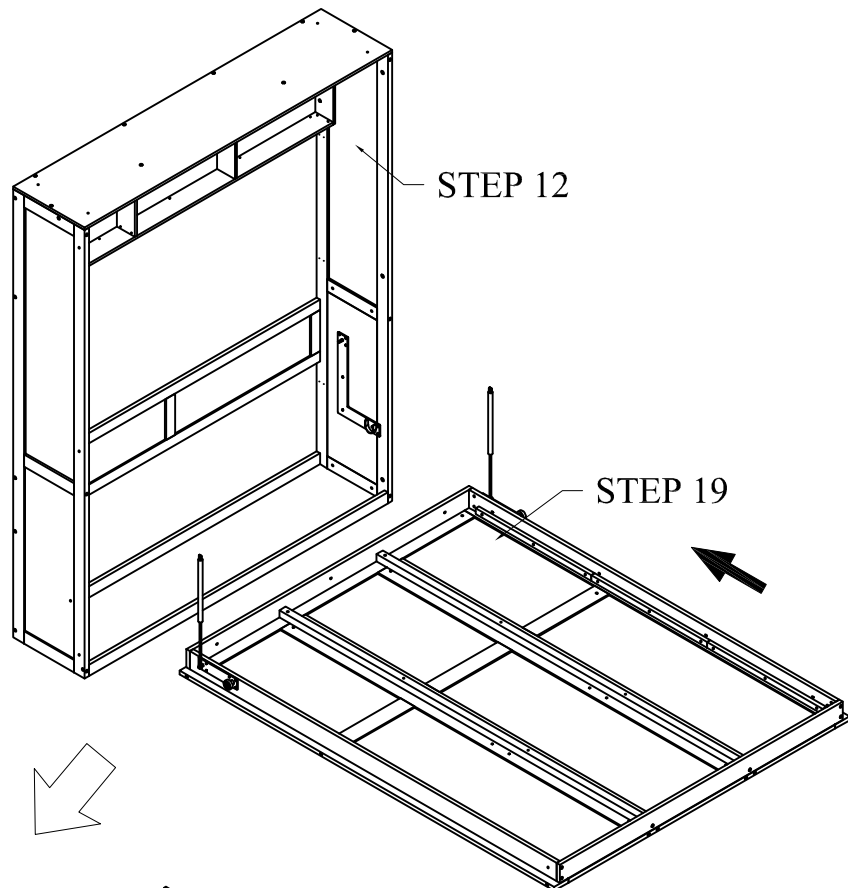

Four people are required to assemble and move this model

Quatre personnes sont nécessaires pour assembler et déplacer ce modèle



STEP 21

Étape

SCAN ME
SCANEZ-MOI



Assembly Video
Vidéo d'assemblage

AA		02
AB		01

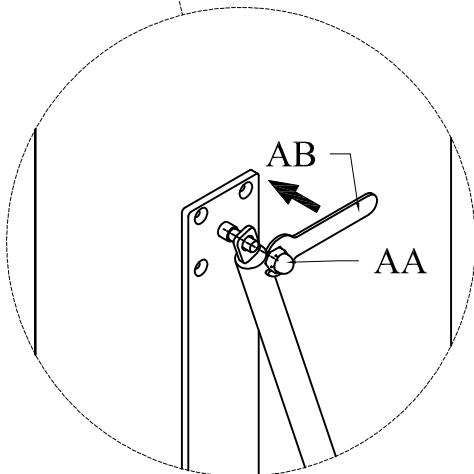
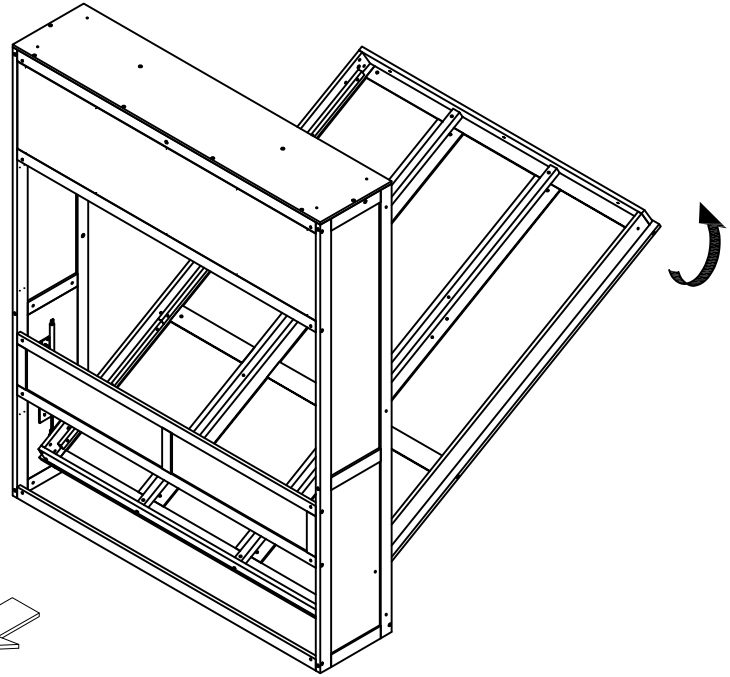
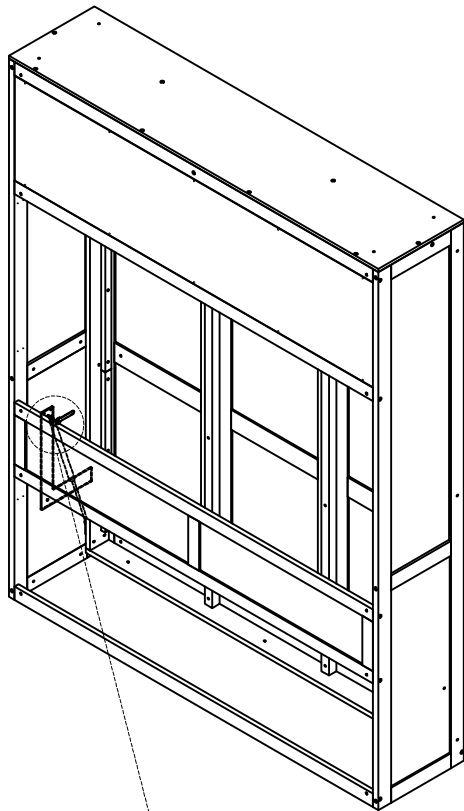

*-Attach the remaining end of the piston to the position on parts (73) and (74).

*-Fixez l'extrémité restante du piston à la position sur les pièces (73) et (74).

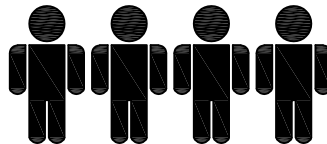

Four people are required to assemble and move this model

Quatre personnes sont nécessaires pour assembler et déplacer ce modèle



STEP 22

Étape

SCAN ME
SCANEZ-MOI



Assembly Video
Vidéo d'assemblage

AG		04
Q		08

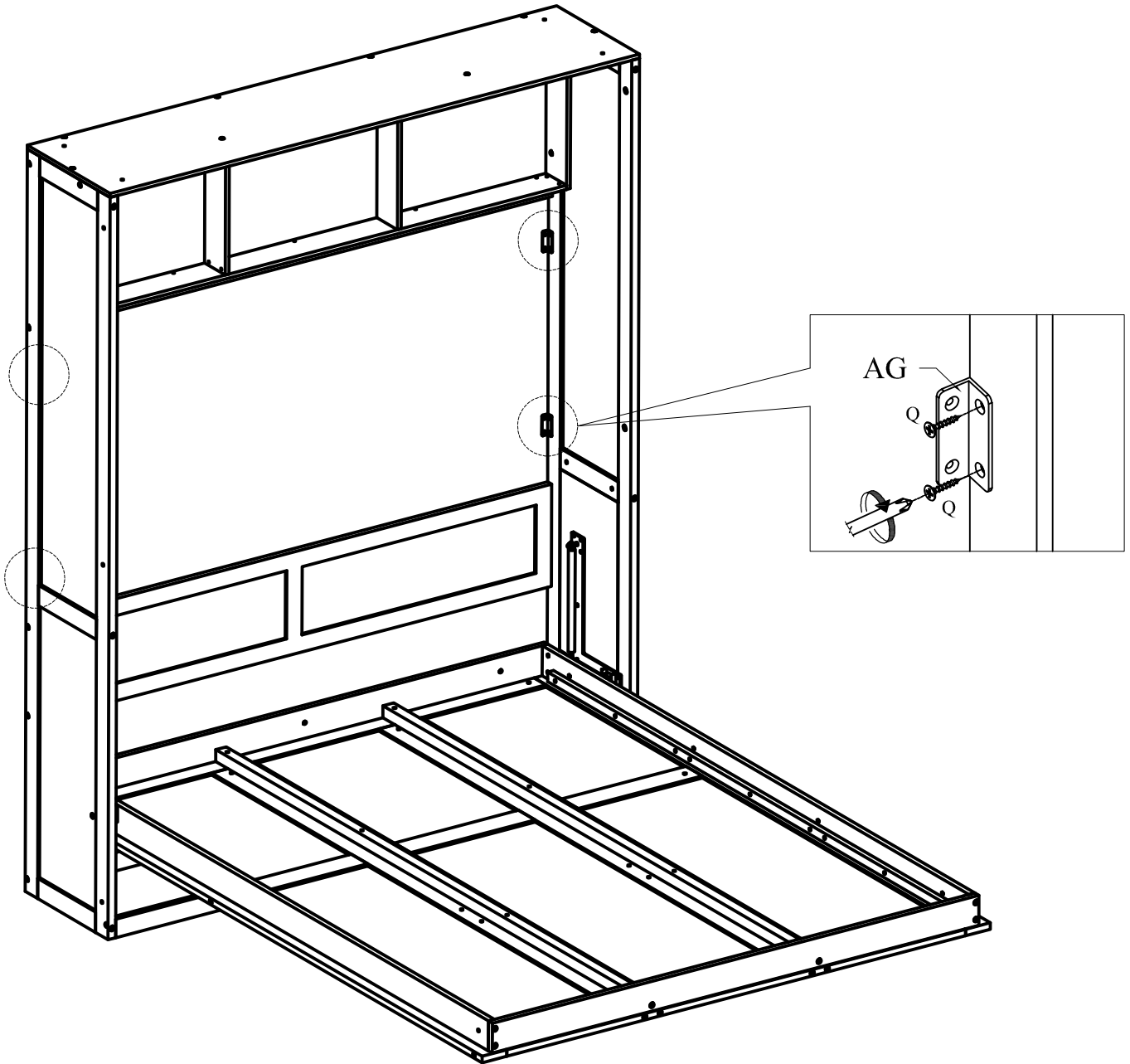

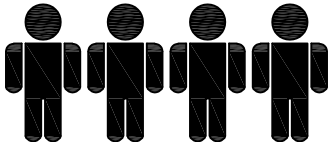
	Four people are required to assemble and move this model Quatre personnes sont nécessaires pour assembler et déplacer ce modèle
---	--

WALL ANCHORING INSTRUCTIONS

INSTRUCTIONS D'ANCRAGE MURAL

- 1** Determine the position of the bed in the room
Déterminez la position du lit dans la pièce.

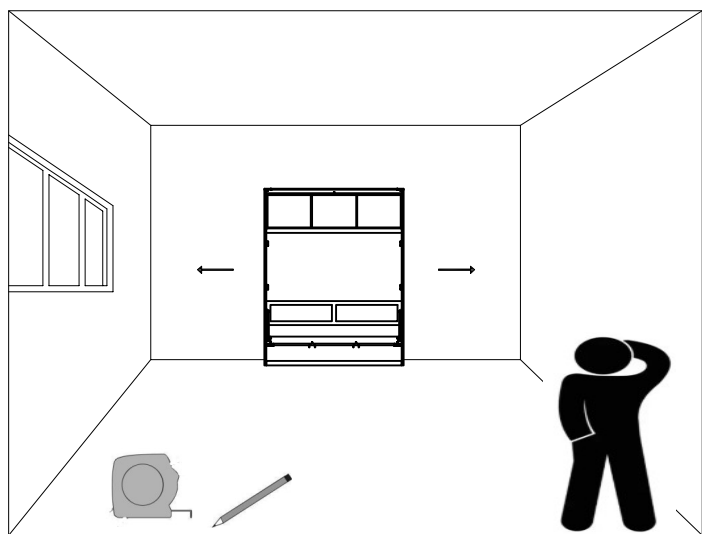

- 2** Put the bed back in its place. Please keep it vertical and horizontal
Remettez le lit à sa place. Veuillez le maintenir vertical et horizontal.

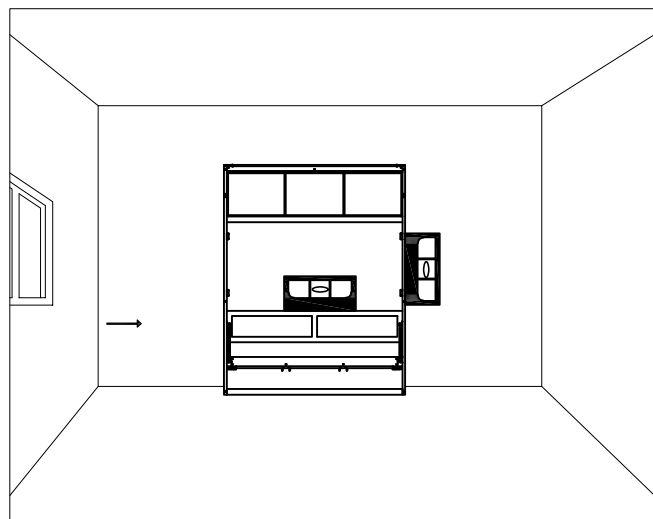

- 3** Mark 8 drilling hole positions on the wall corresponding to the pattern (AG).
Marquez les 8 positions des trous de perçage sur le mur en suivant le gabarit (AG).

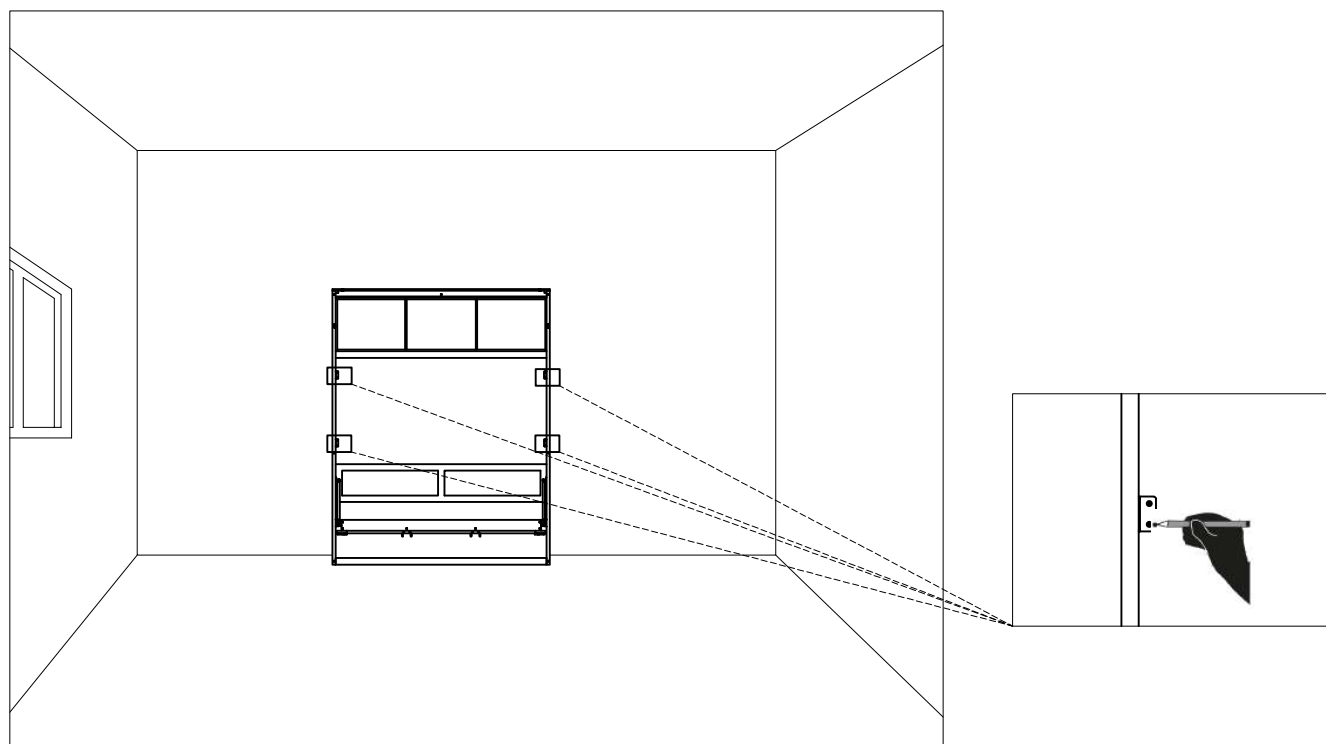

- 4** Move the bed again, then use a wall drill with an 8mm drill bit to drill into the marked positions, ensuring the hole depth exceeds 50mm.

Déplacez de nouveau le lit, puis utilisez une perceuse murale avec un foret de 8 mm pour percer aux emplacements marqués, en veillant à ce que la profondeur des trous dépasse 50 mm.

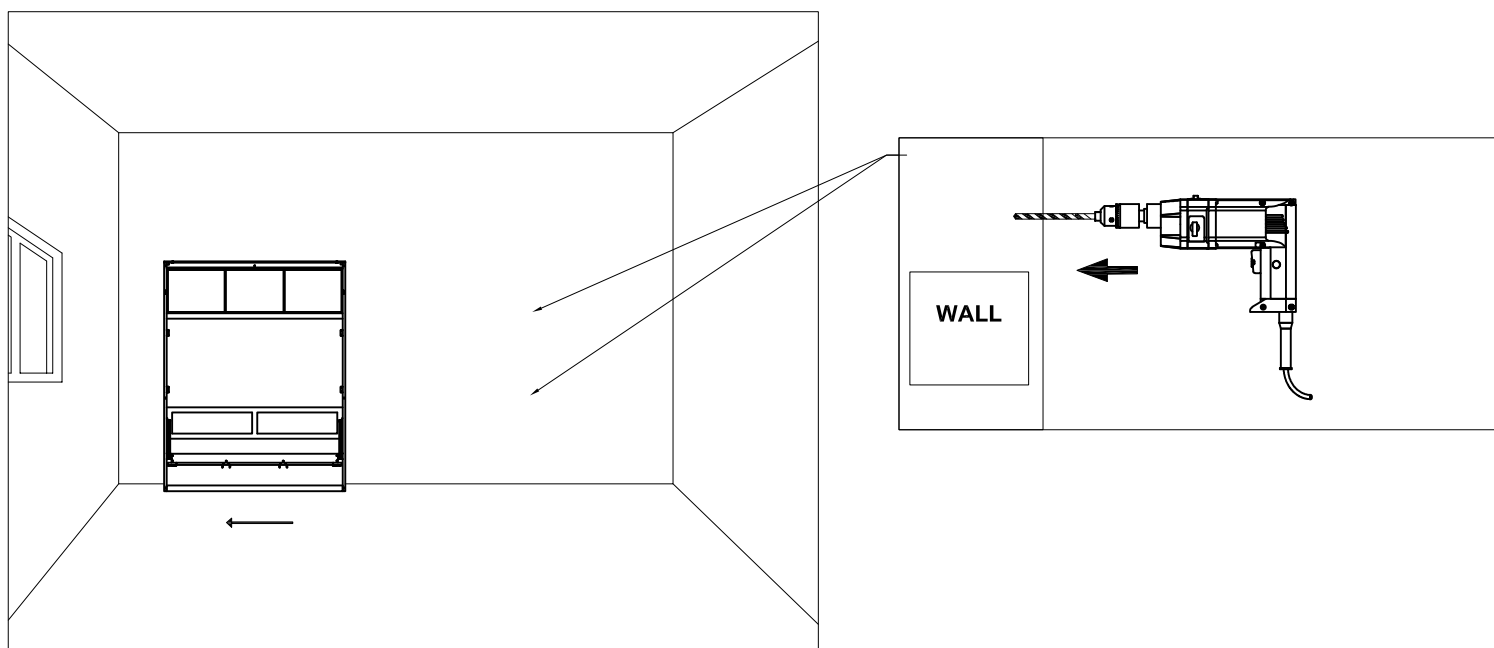

- 5** Insert plastic stopper (Z) into the drilled holes on the wall.

Insérez les chevilles en plastique (Z) dans les trous percés dans le mur.

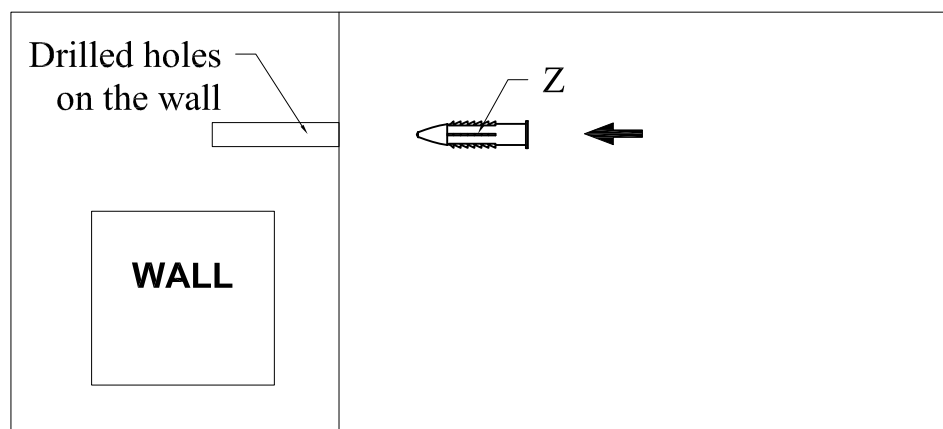

- 6** Put the bed back in its place. Use screws to securely attach the bed to the wall.

Remettez le lit à sa place. Utilisez des vis pour fixer fermement le lit au mur.

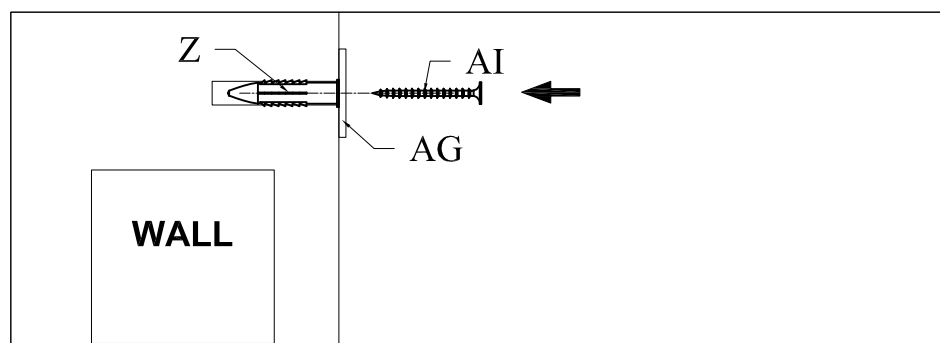

STEP 23

Étape

SCAN ME



Assembly Video



08

*-Position on the wall to align the plastic stopper (Z) with the hole positions on the patt (AG) at the bed's location

Positionnez sur le mur pour aligner les chevilles en plastique (Z) avec les positions des trous du gabarit (AG) à l'emplacement du lit.

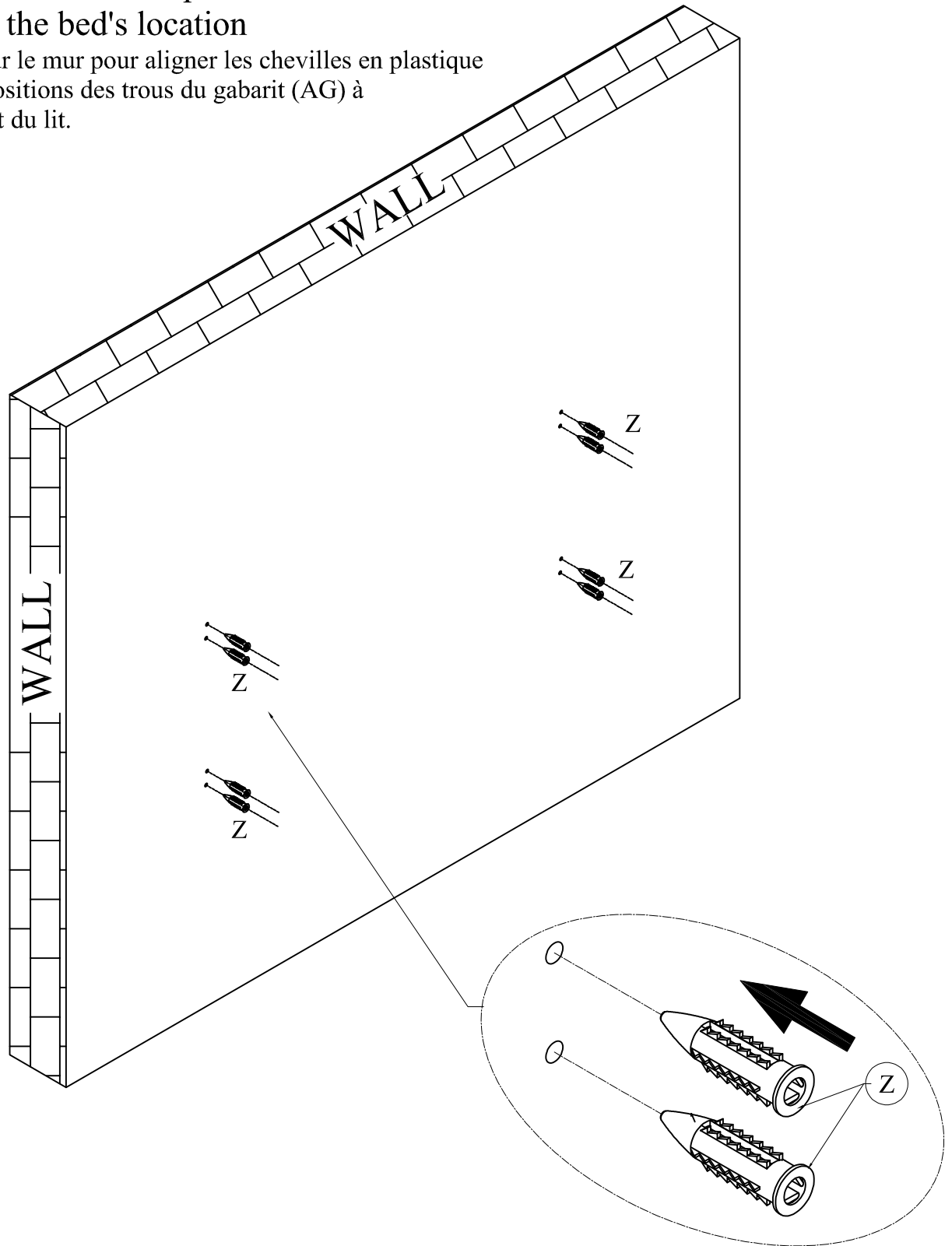

STEP 24

Étape

SCAN ME
SCANEZ-MOI



Assembly Video
Vidéo d'assemblage

AI

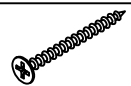

08

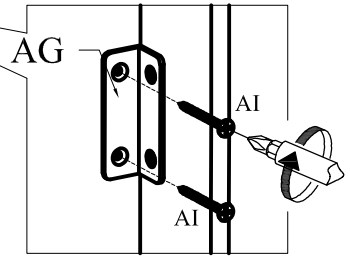
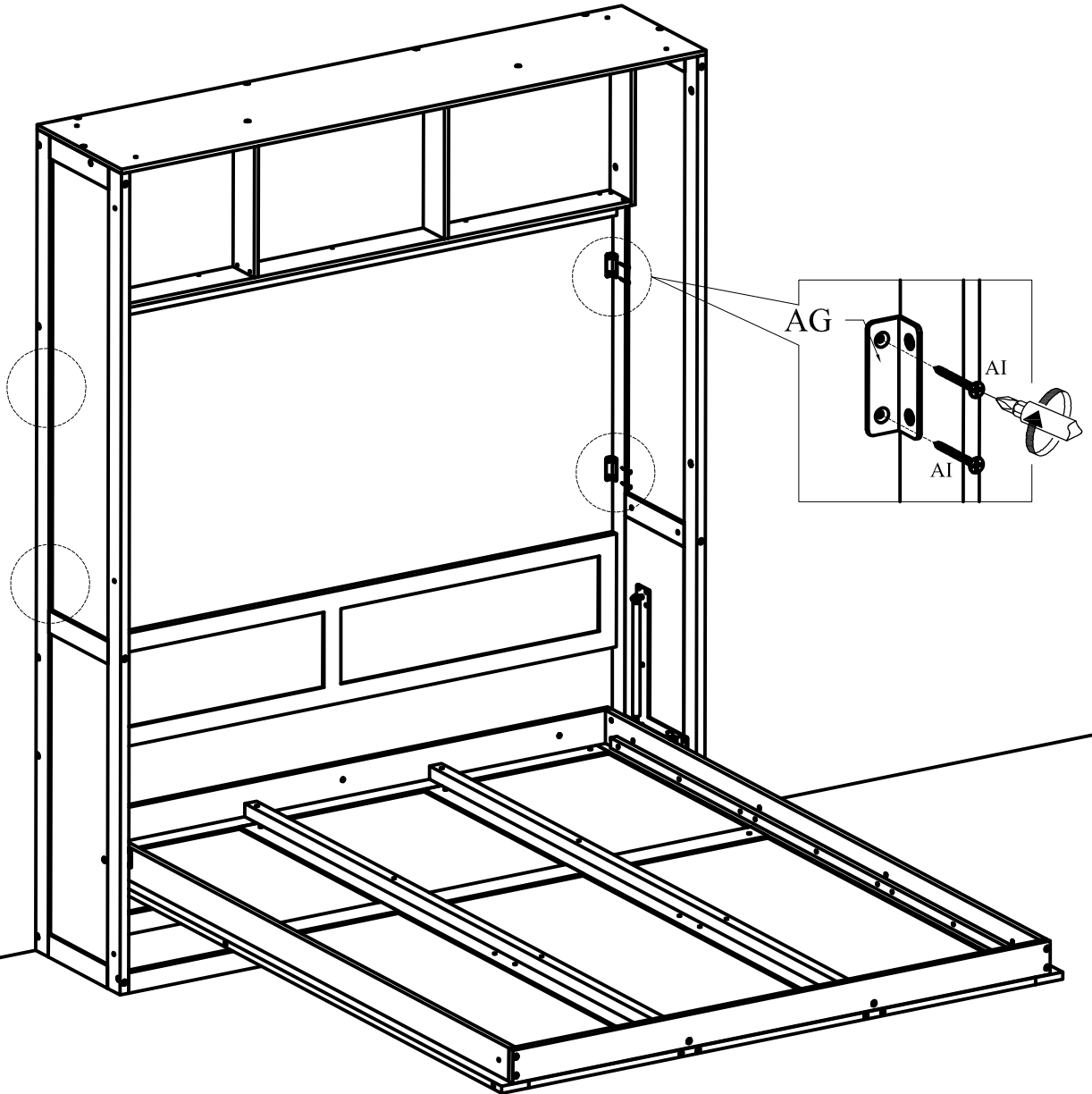

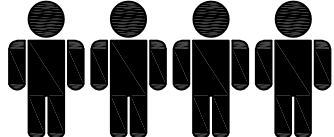
 Four people are required to assemble and move this model
Quatre personnes sont nécessaires pour assembler et déplacer ce modèle



STEP 25

Étape

SCAN ME
SCANEZ-MOI



Assembly Video
Vidéo d'assemblage

(D)		02
(L)		02

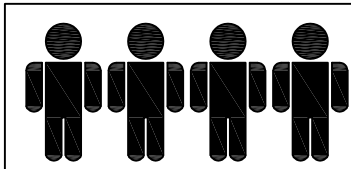
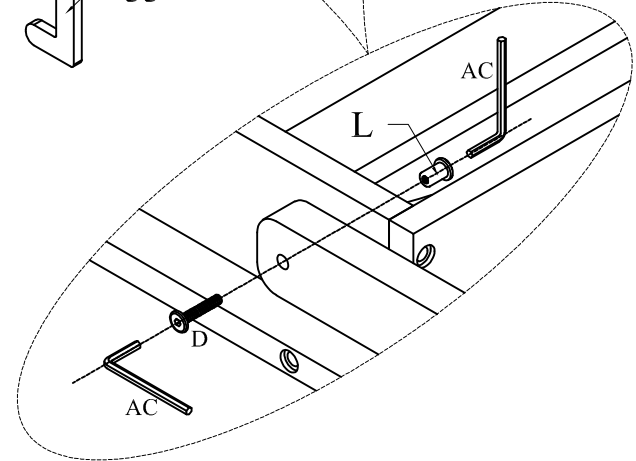
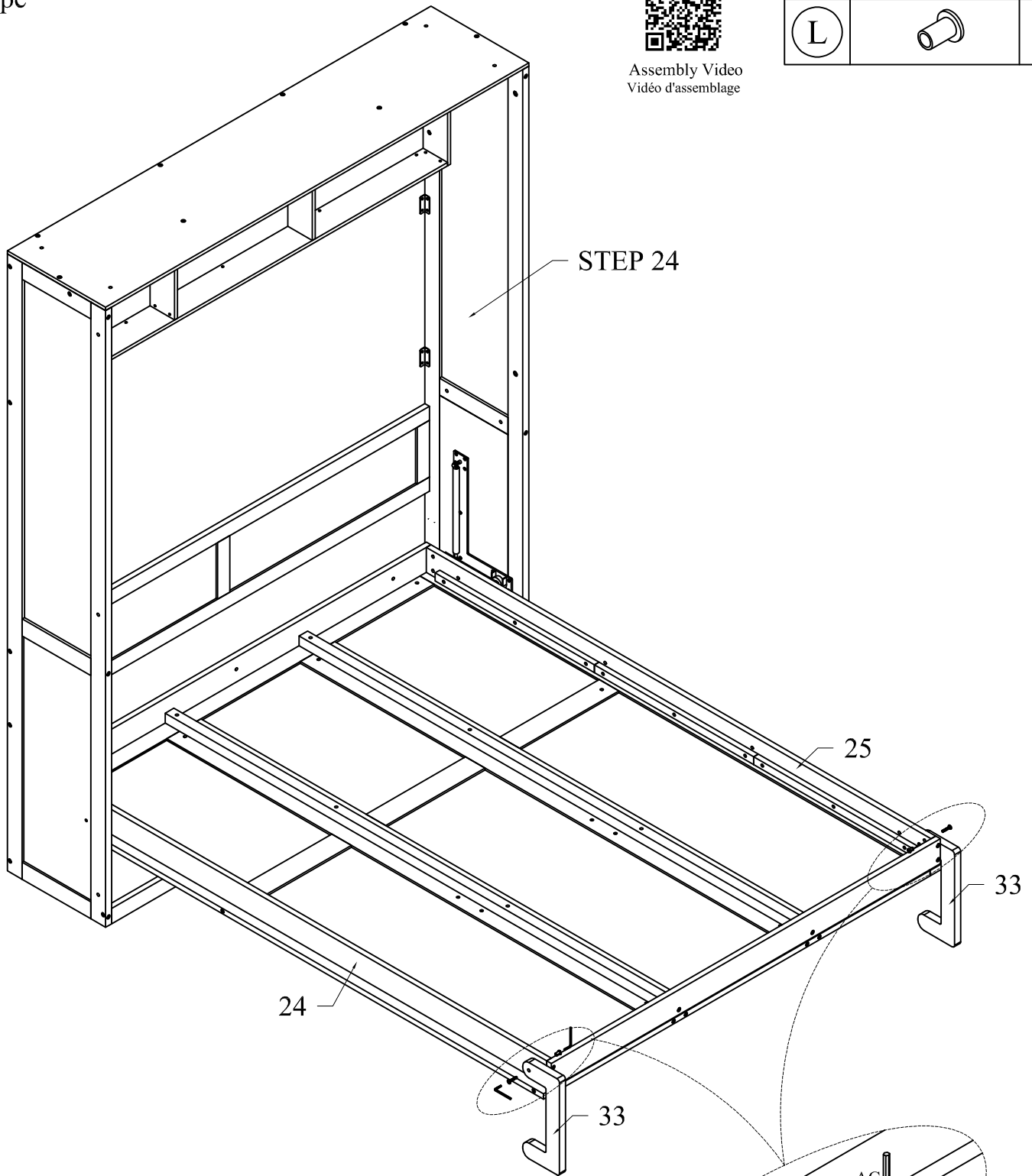

Four people are required to assemble and move this model
Quatre personnes sont nécessaires pour assembler et déplacer ce modèle

STEP 26

Étape

SCAN ME
SCANEZ-MOI



Assembly Video
Vidéo d'assemblage

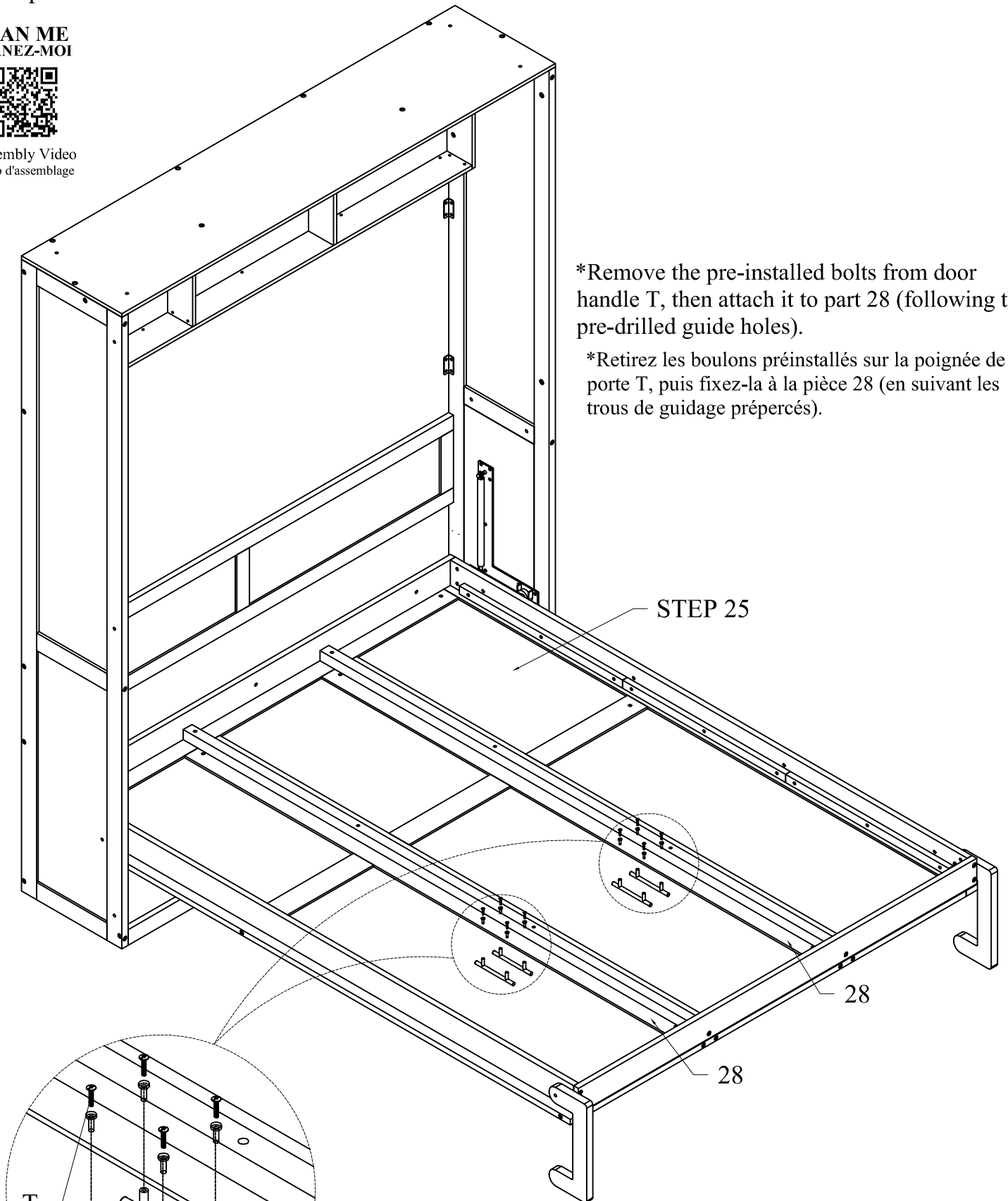
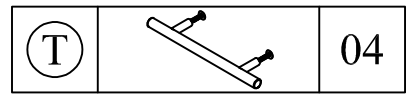

*Remove the pre-installed bolts from door handle T, then attach it to part 28 (following the pre-drilled guide holes).

*Retirez les boulons préinstallés sur la poignée de porte T, puis fixez-la à la pièce 28 (en suivant les trous de guidage prépercés).

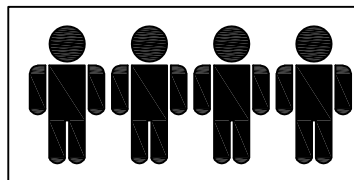
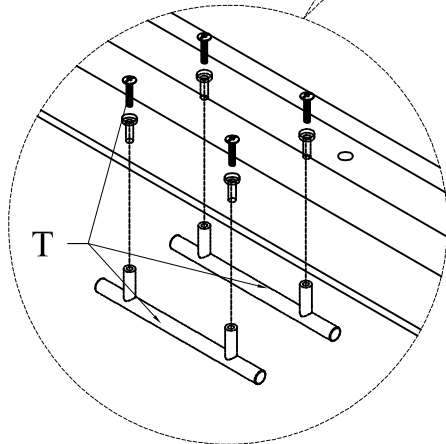

Four people are required to assemble and move this model

Quatre personnes sont nécessaires pour assembler et déplacer ce modèle

STEP 27

Étape

SCAN ME
SCANEZ-MOI



Assembly Video
Vidéo d'assemblage

(R)		24
-----	--	----

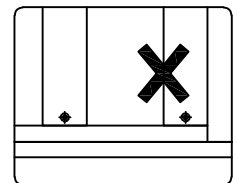
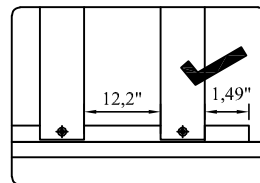
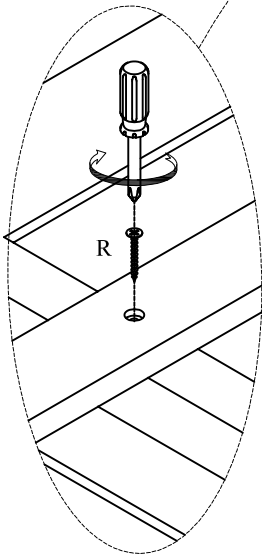
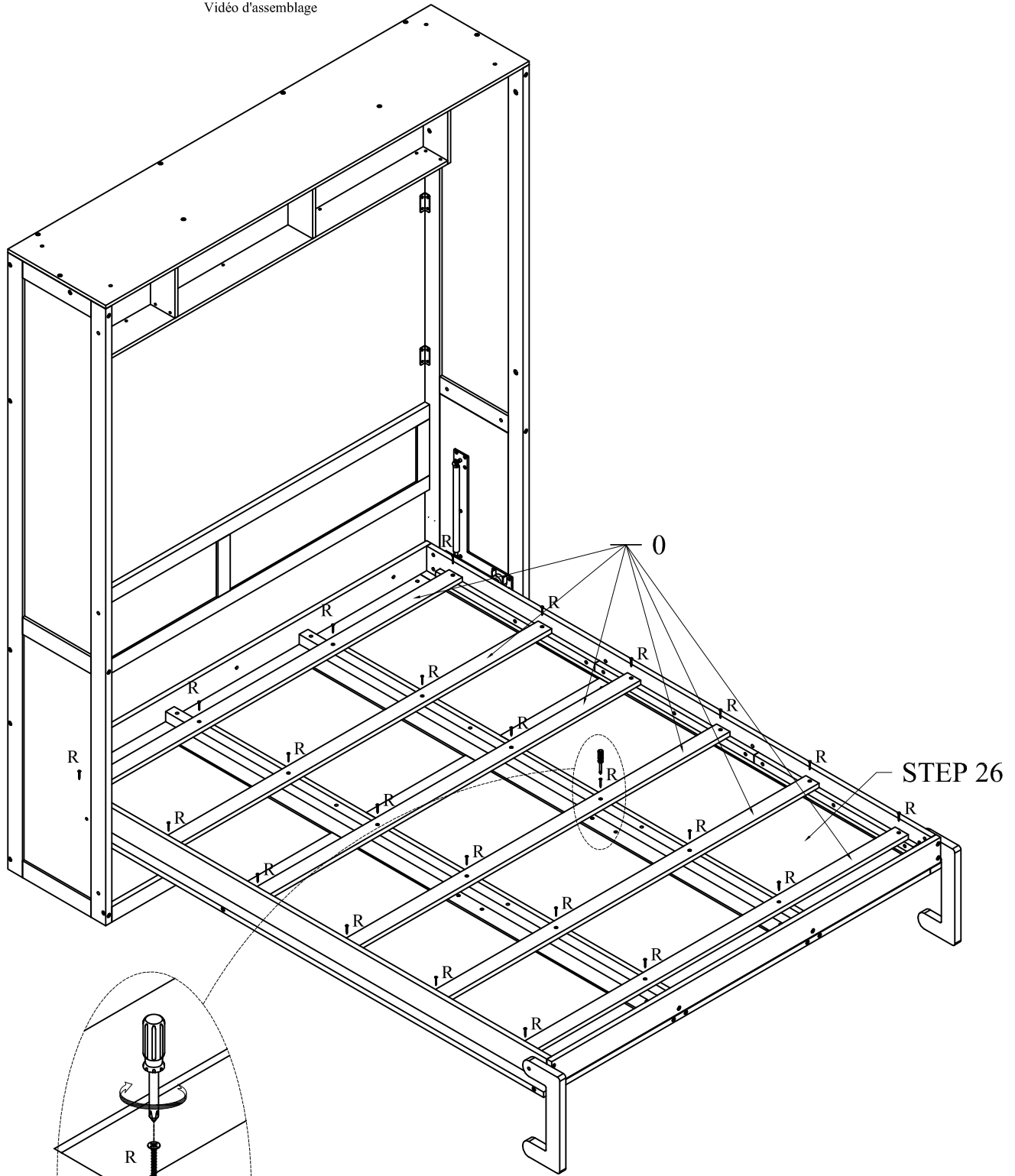



STEP 28

Étape

SCAN ME
SCANEZ-MOI



Assembly Video
Vidéo d'assemblage

(R)		04
(AE)		02

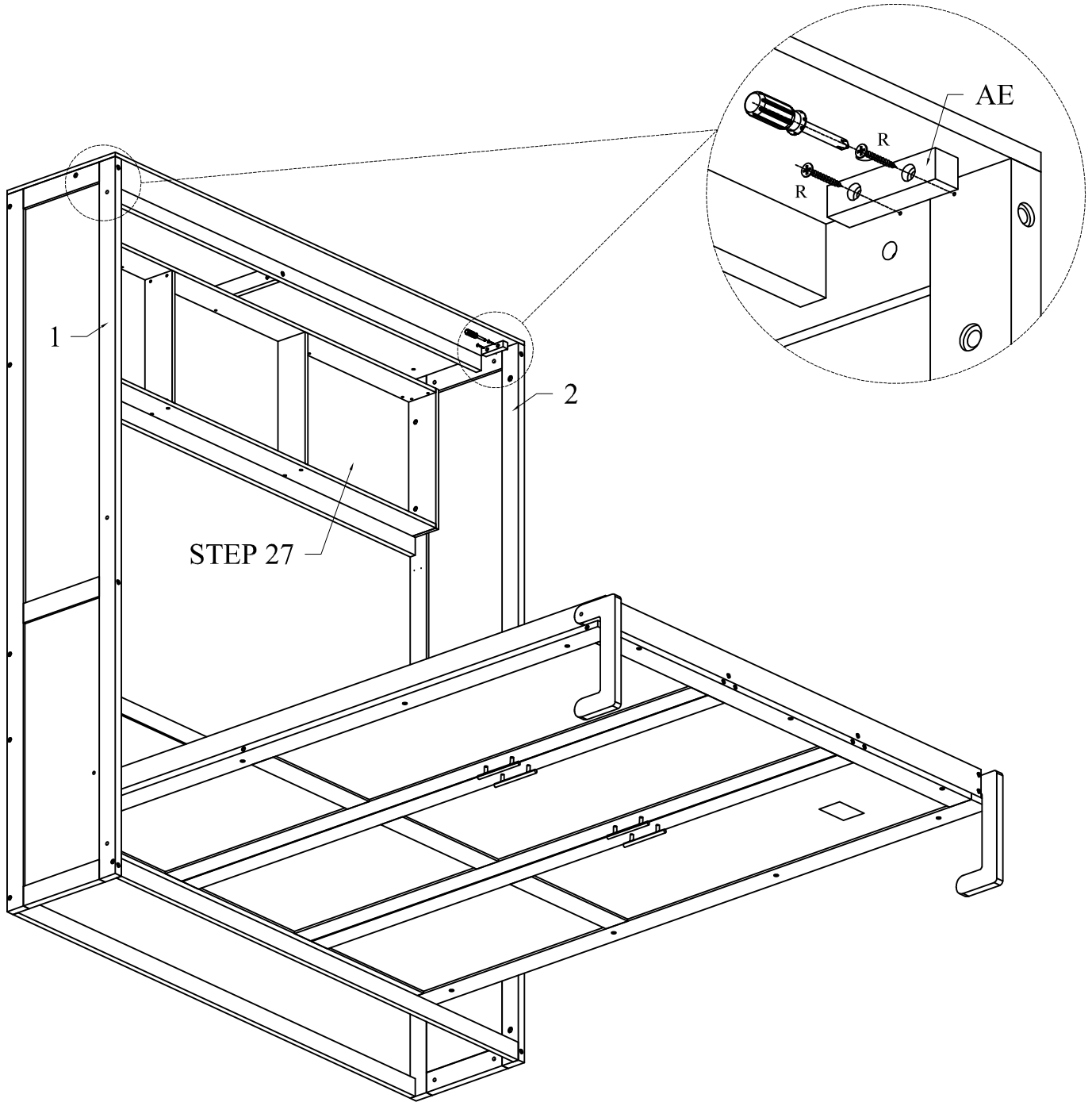

STEP 29

Étape

SCAN ME
SCANEZ-MOI



Assembly Video
Vidéo d'assemblage

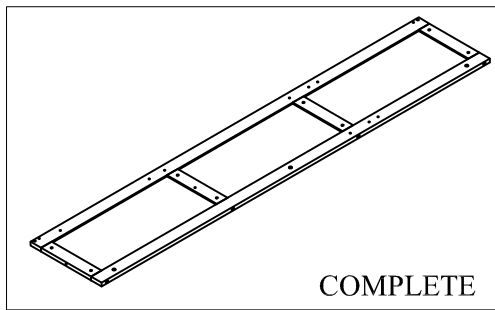

COMPLETE

(I)		08
(K)		08

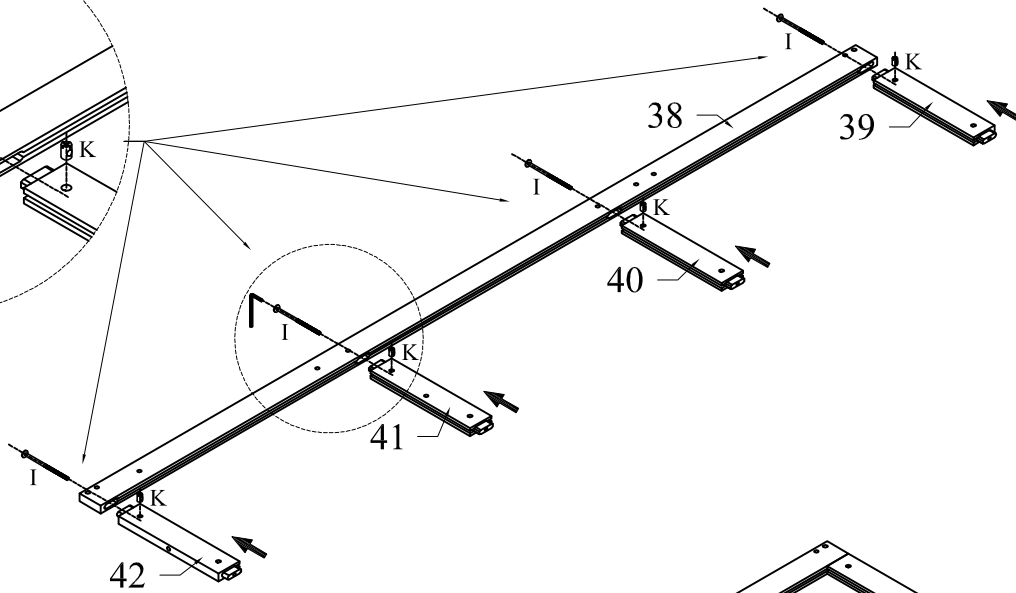
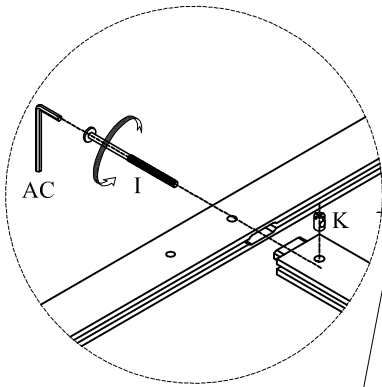

STEP 29.1

Étape

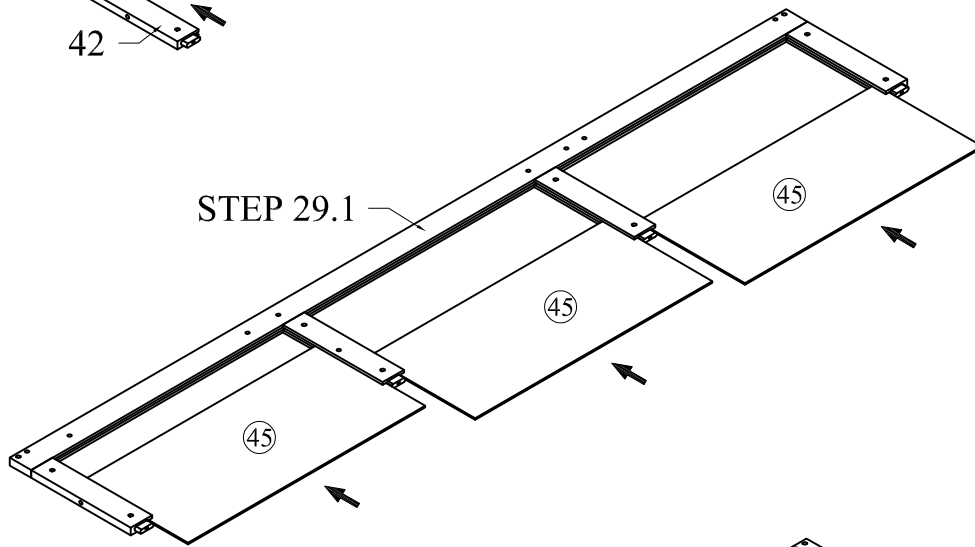

STEP 29.2

Étape

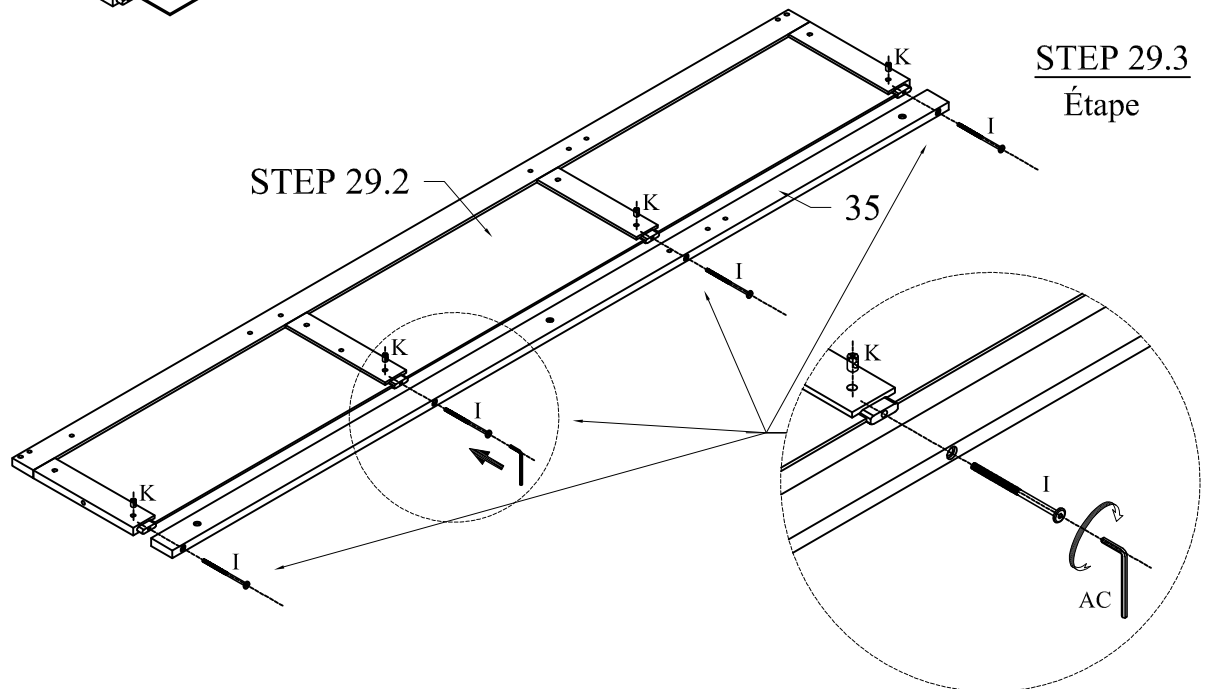

STEP 29.3

Étape

STEP 30

Étape

SCAN ME
SCANEZ-MOI



Assembly Video
Vidéo d'assemblage

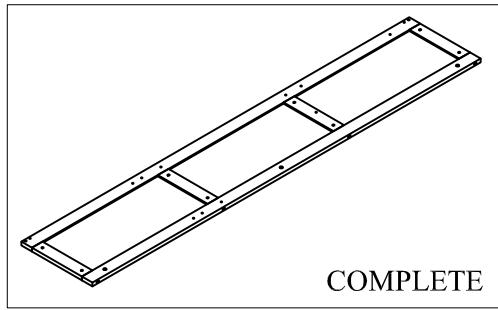

COMPLETE

(I)		08
(K)		08

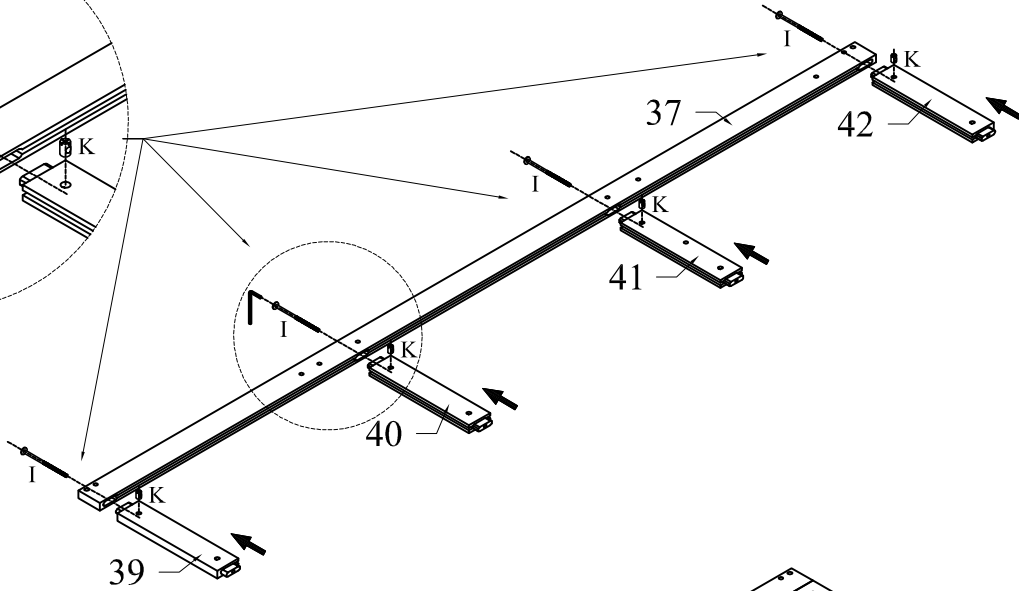
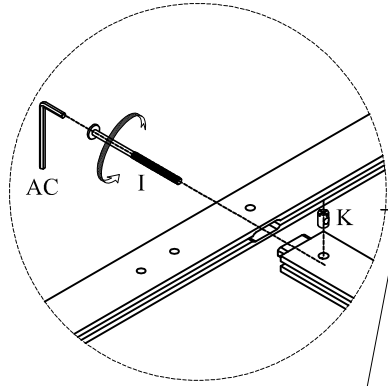

STEP 30.1
Étape

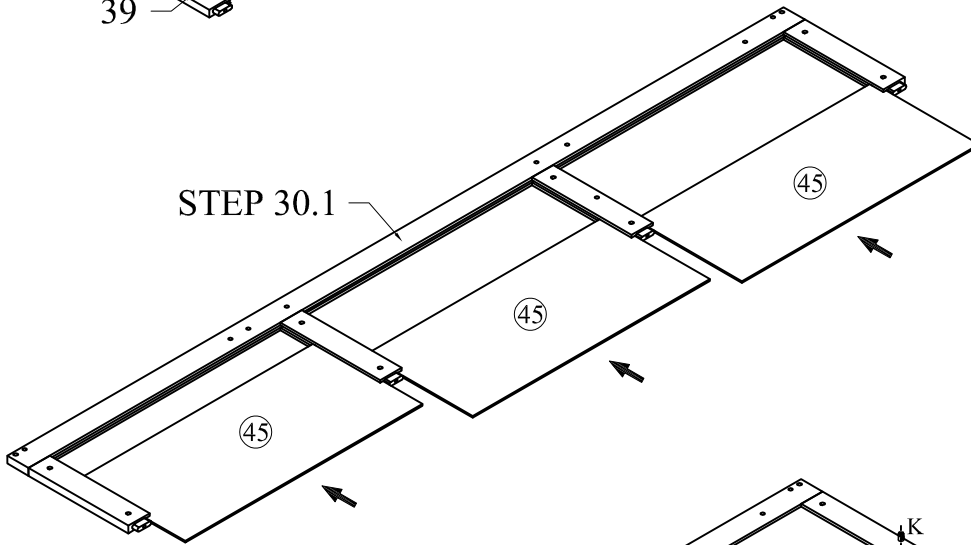

STEP 30.2
Étape

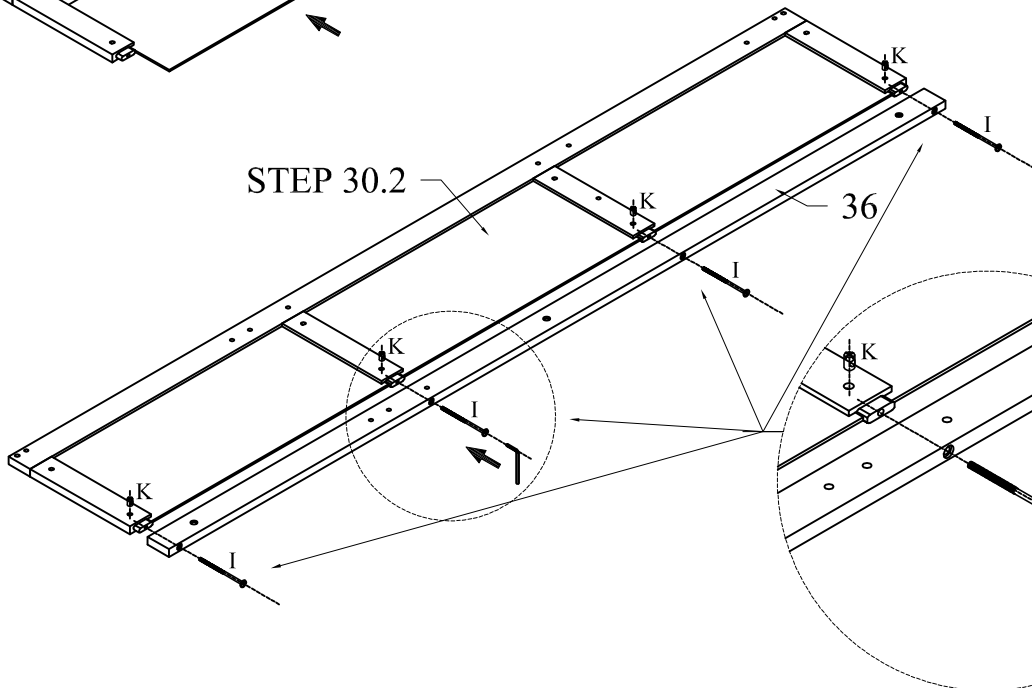

STEP 30.3
Étape

STEP 31

Étape

SCAN ME
SCANEZ-MOI



Assembly Video
Vidéo d'assemblage

Y		08
---	--	----

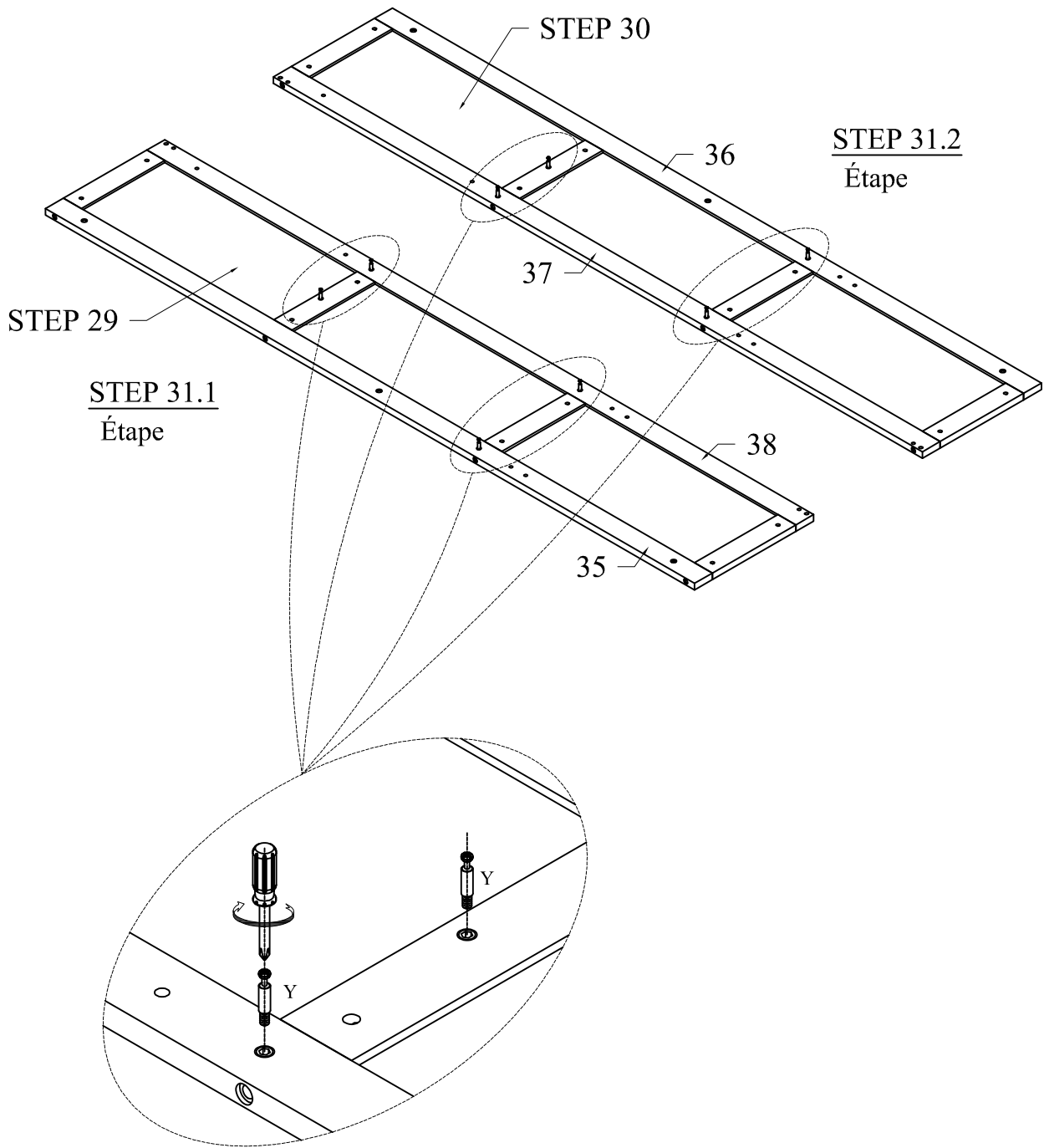

STEP 31.2
Étape

STEP 31.1
Étape

STEP 32

Étape

SCAN ME
SCANEZ-MOI



Assembly Video
Vidéo d'assemblage

©		08
---	--	----

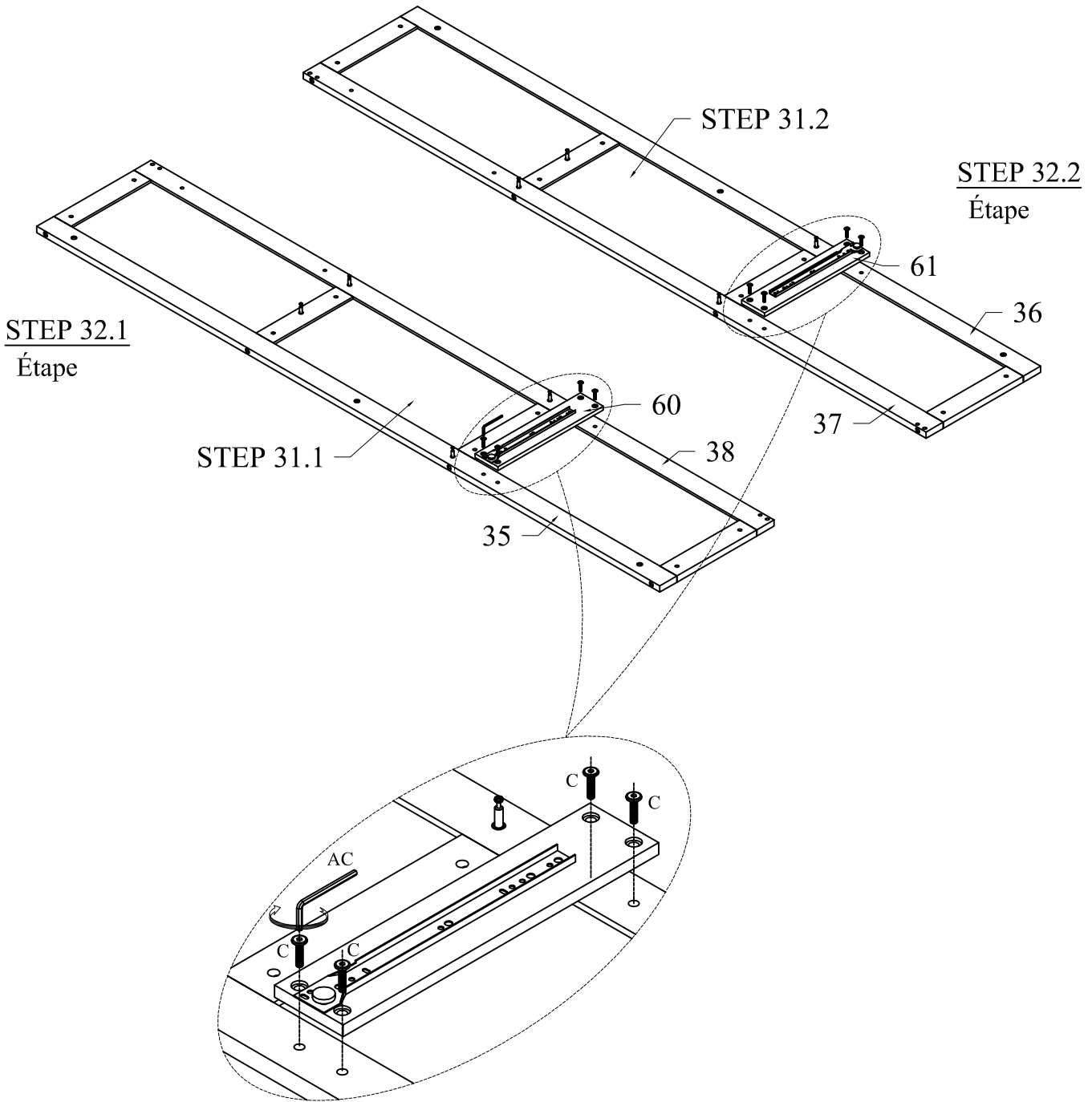
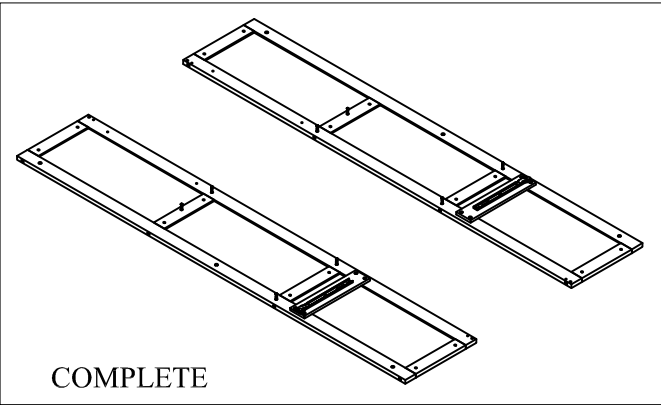

STEP 33

Étape

SCAN ME
SCANEZ-MOI



Assembly Video
Vidéo d'assemblage

(R)		08
-----	--	----

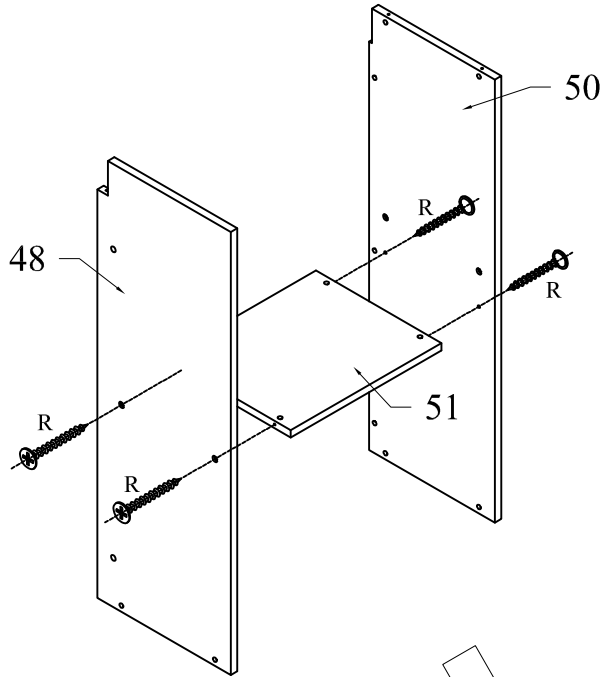
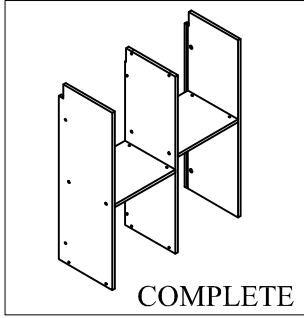

STEP 33.1
Étape

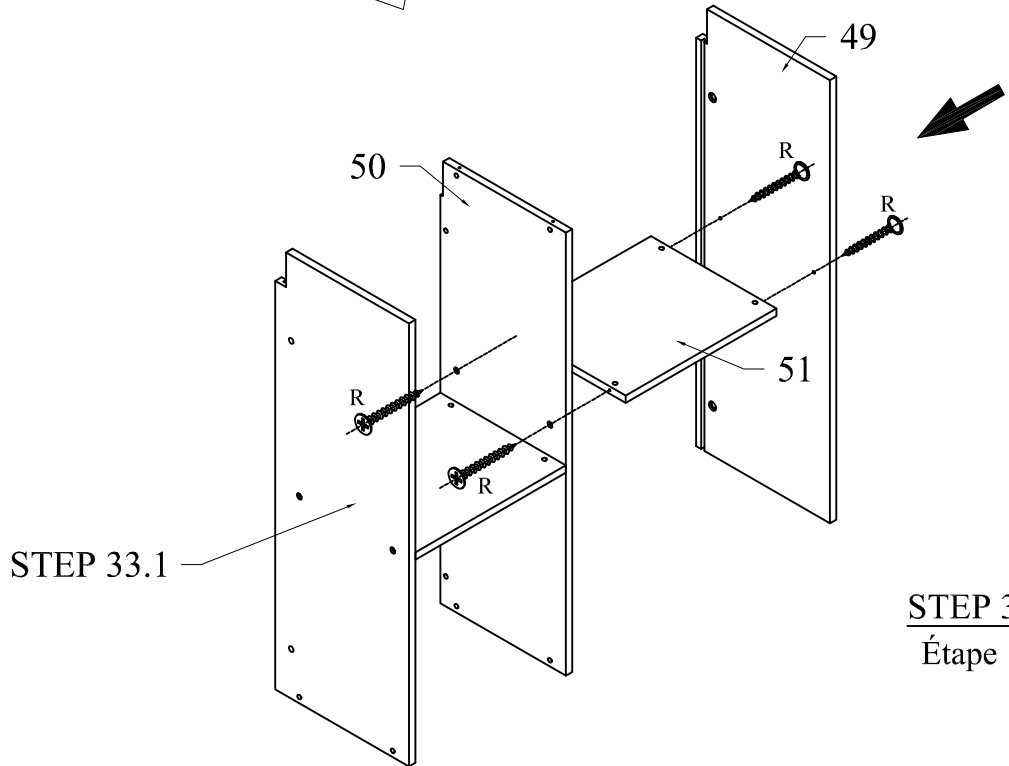
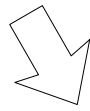

STEP 33.2
Étape

STEP 34

Étape

SCAN ME
SCANEZ-MOI



Assembly Video
Vidéo d'assemblage

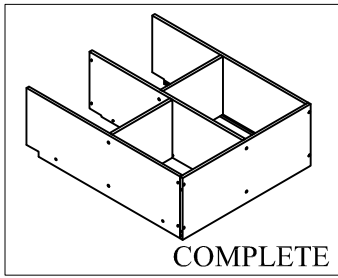
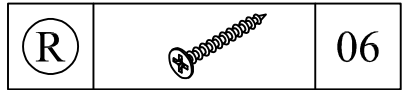

Flip the parts in Step 33 as described and continue.

Retournez les pièces à l'étape 33 comme décrit et continuez.

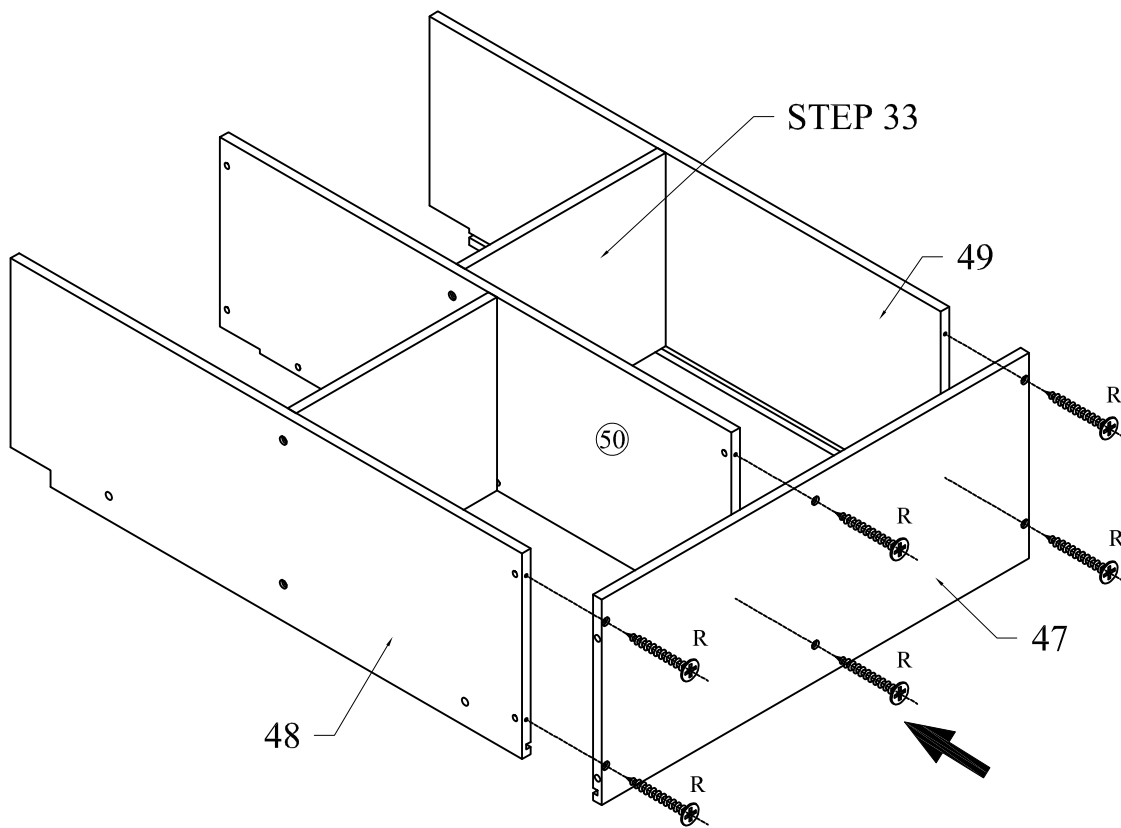

STEP 35

Étape

SCAN ME
SCANEZ-MOI



Assembly Video
Vidéo d'assemblage

N		03
---	---	----

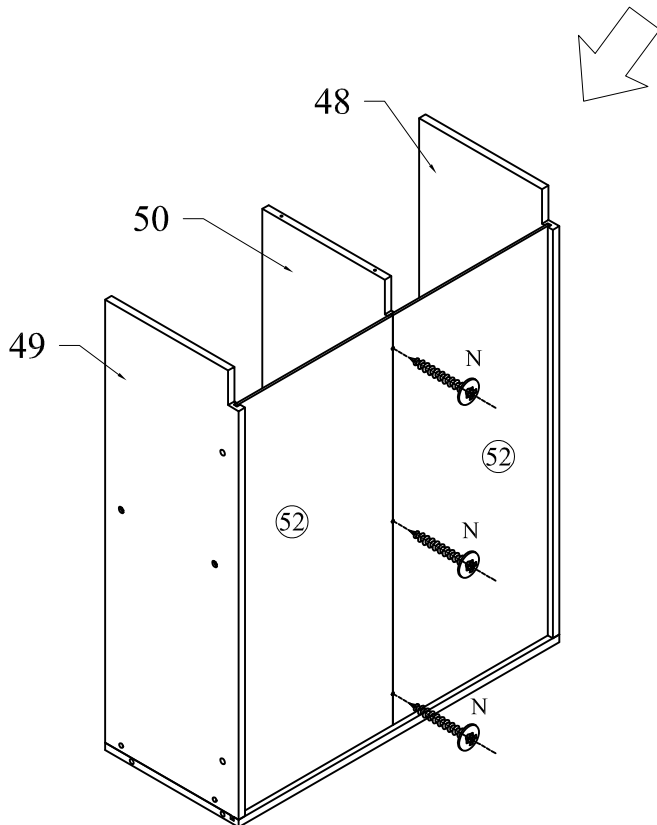
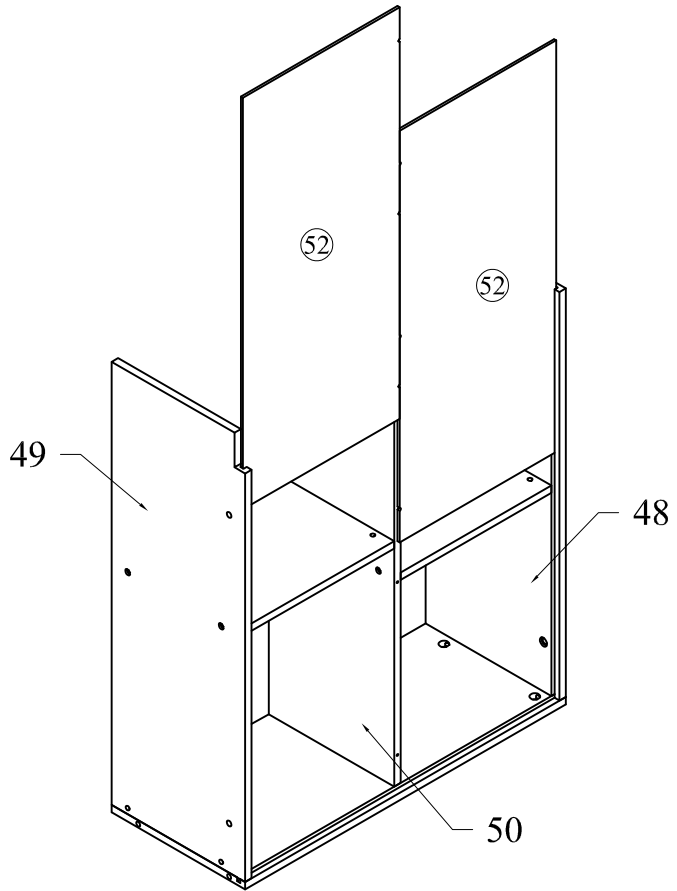
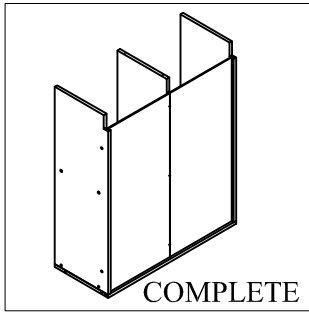

STEP 36

Étape

SCAN ME
SCANEZ-MOI



Assembly Video
Vidéo d'assemblage

(A)		02
(C)		02
(F)		02
(K)		02
(Y)		04

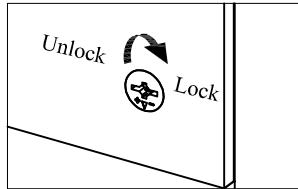
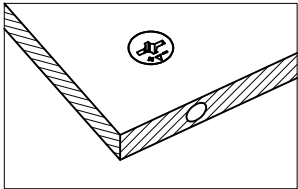
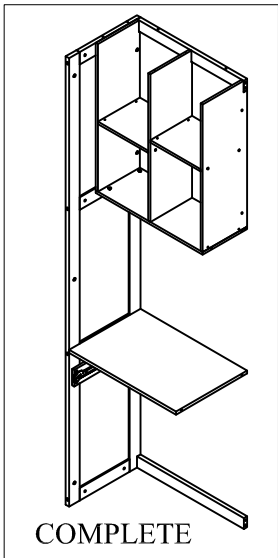

Proper orientation of the CAMLOCK
Sens d'installation correct du verrou à came

STEP 32.1

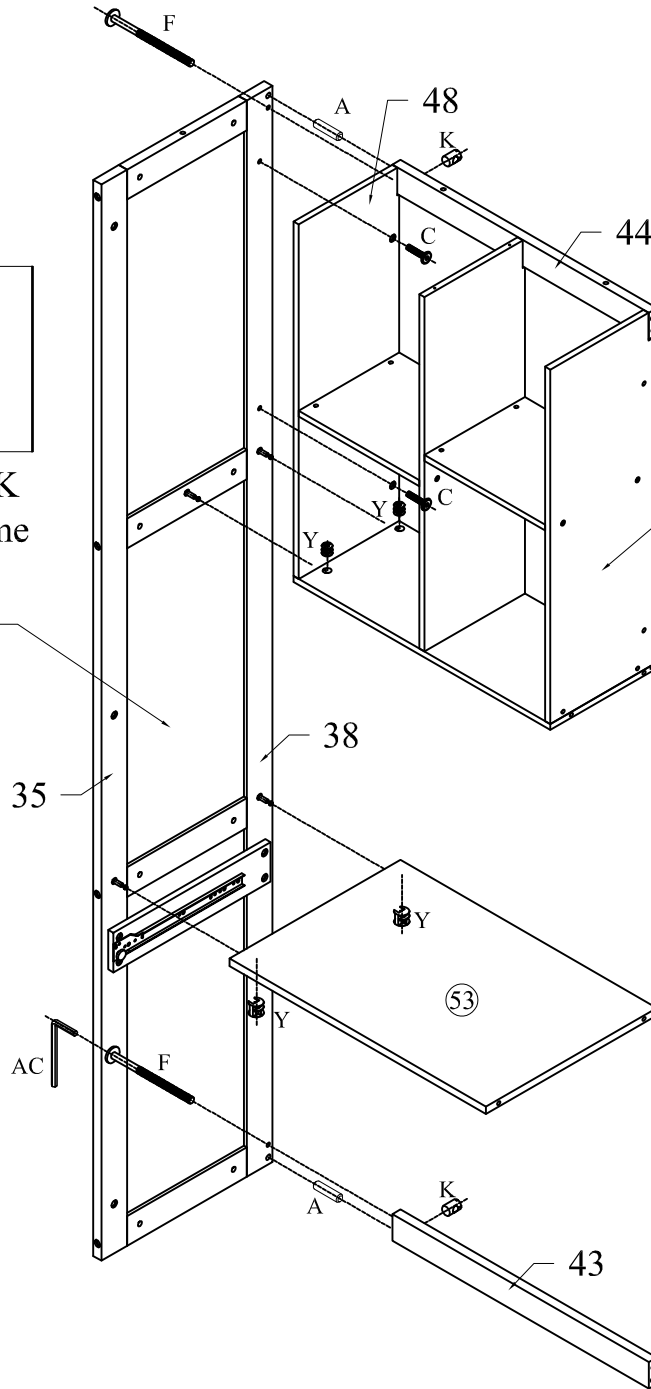

STEP 35

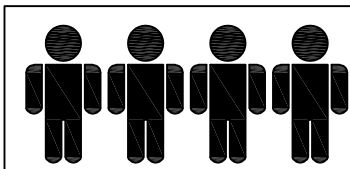

Four people are required to
assemble and move this model

Quatre personnes sont nécessaires pour
assembler et déplacer ce modèle

STEP 37

Étape

SCAN ME
SCANEZ-MOI



Assembly Video
Vidéo d'assemblage

(A)		02
(C)		02
(F)		02
(K)		02
(Y)		04

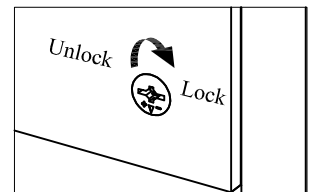
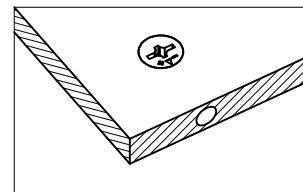
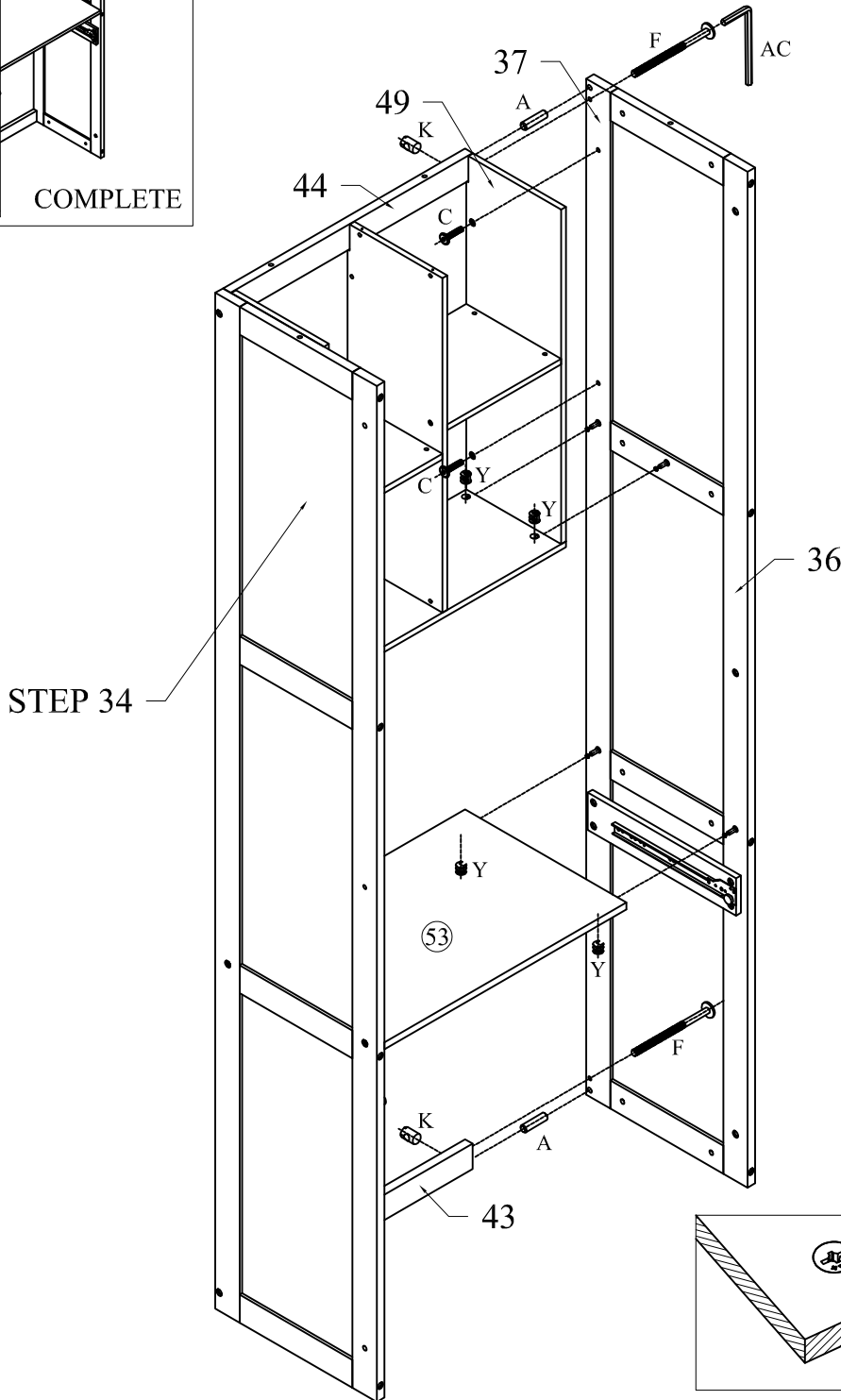
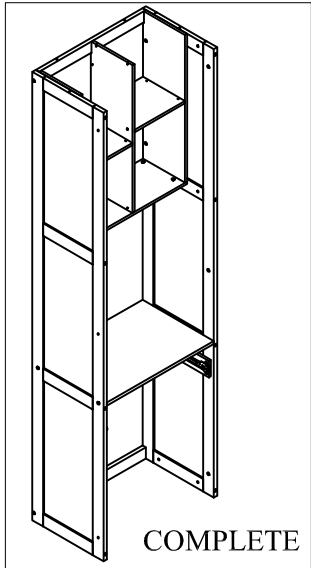

Proper orientation of the CAMLOCK
Sens d'installation correct du verrou à came

Four people are required to assemble and move this model
Quatre personnes sont nécessaires pour assembler et déplacer ce modèle

STEP 38

Étape

SCAN ME
SCANEZ-MOI

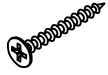

Assembly Video
Vidéo d'assemblage

(C)		04
(R)		02

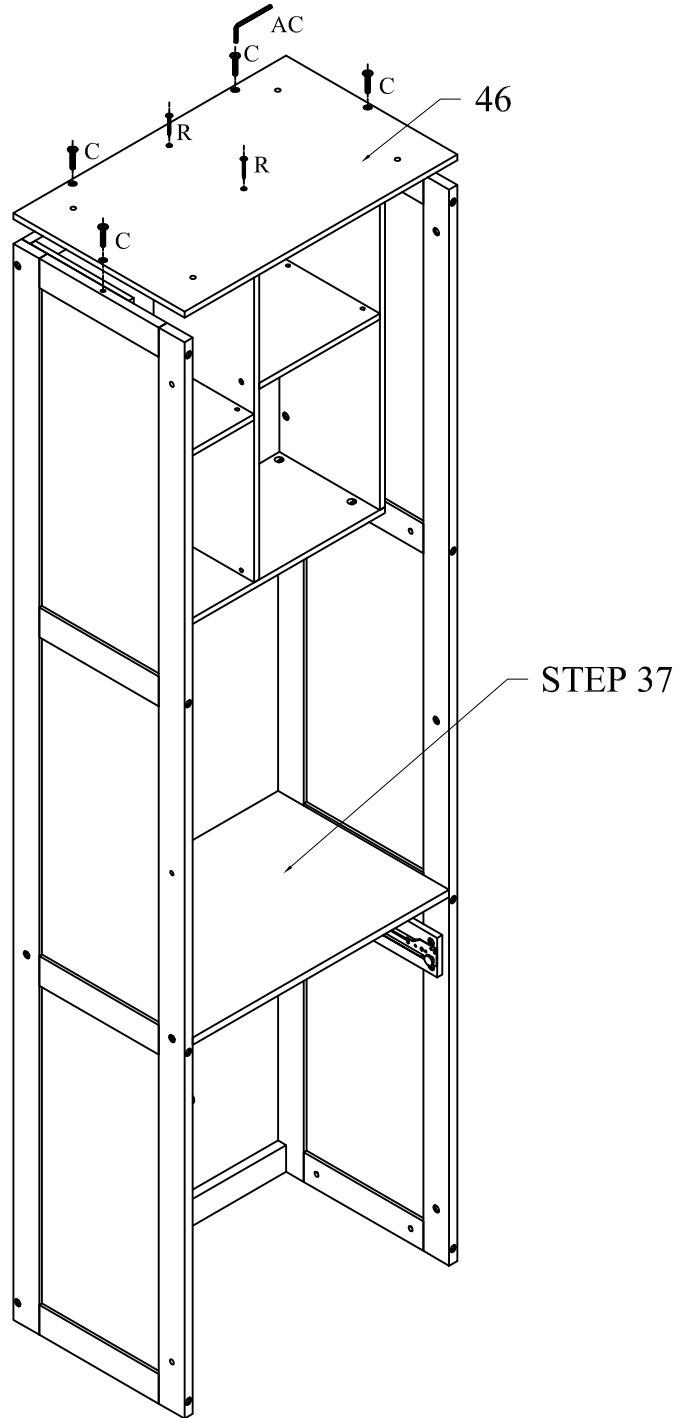
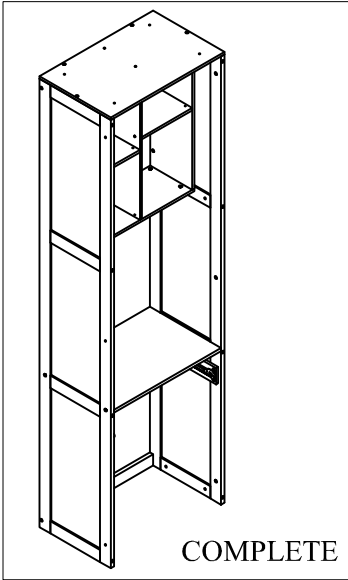

STEP 39

Étape

SCAN ME
SCANEZ-MOI



Assembly Video
Vidéo d'assemblage



04

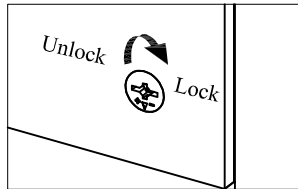
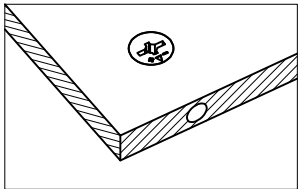
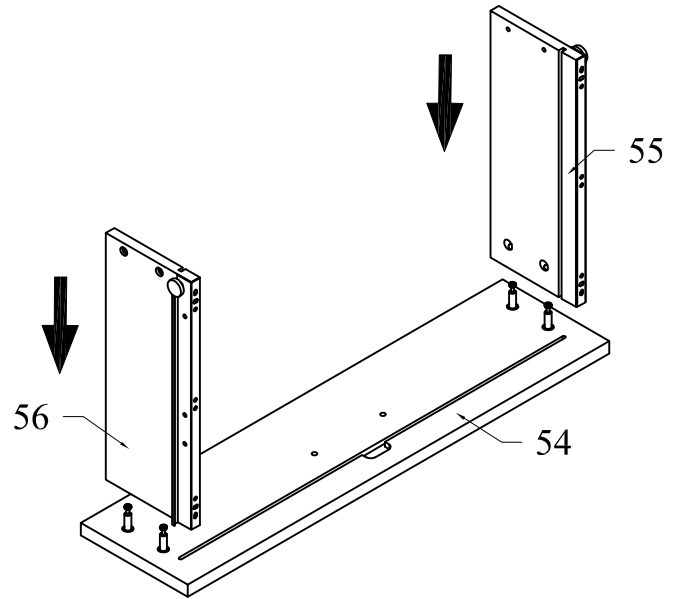
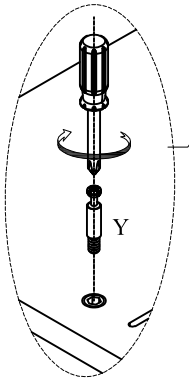
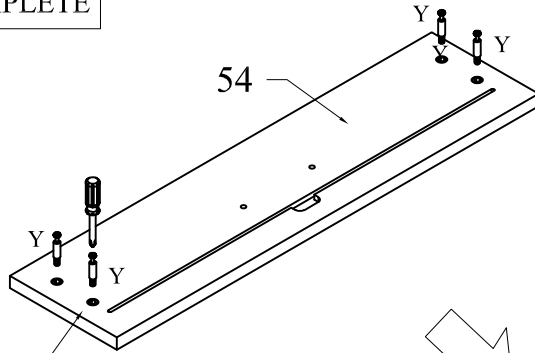
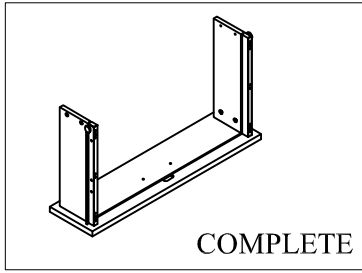

Proper orientation of the CAMLOCK
Sens d'installation correct du verrou à came

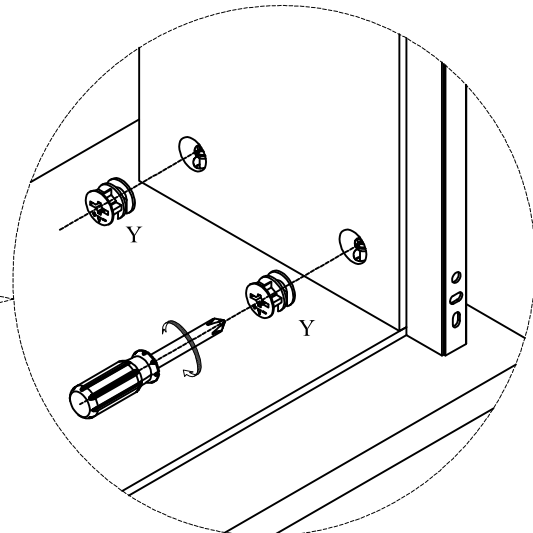
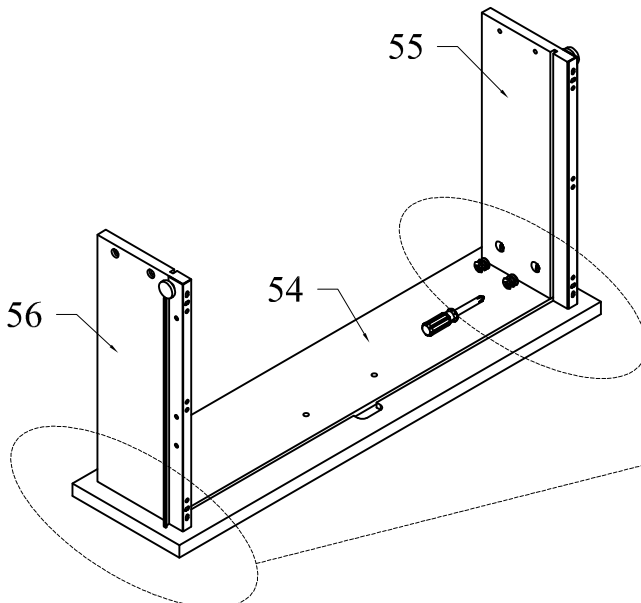

STEP 40

Étape

SCAN ME
SCANEZ-MOI



Assembly Video
Vidéo d'assemblage

(R)		05
-----	--	----

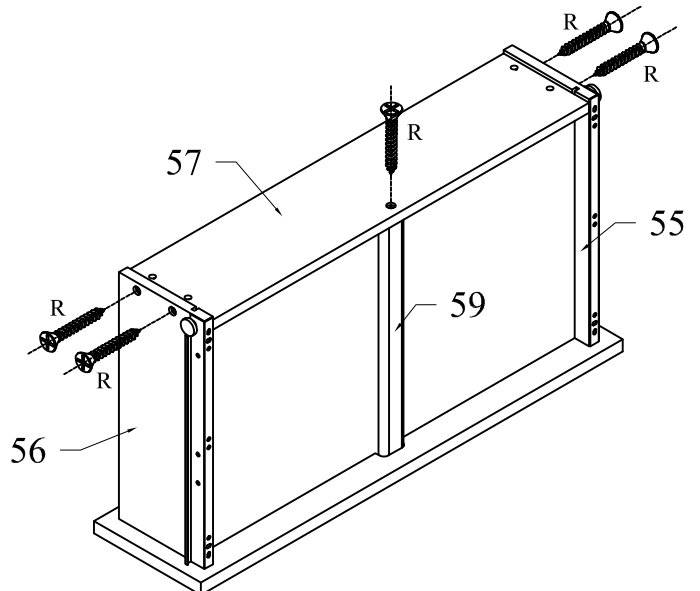
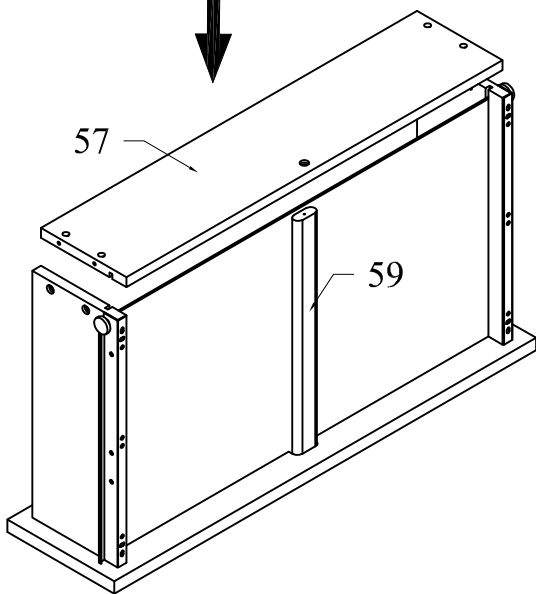
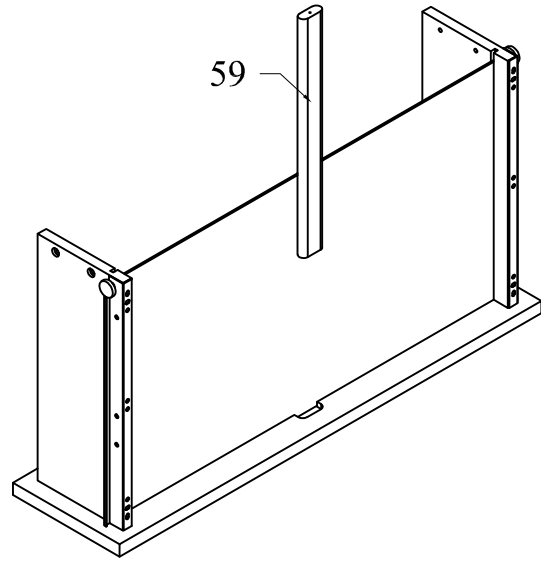
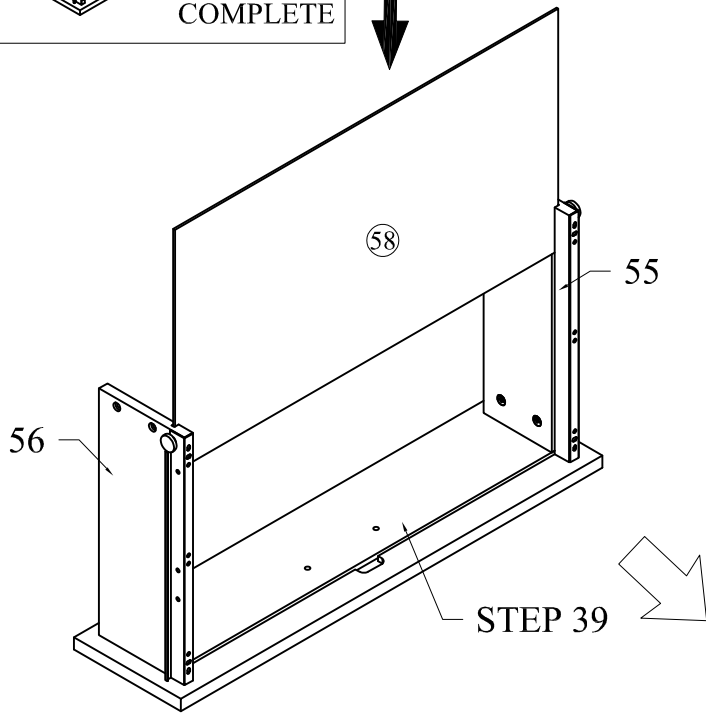
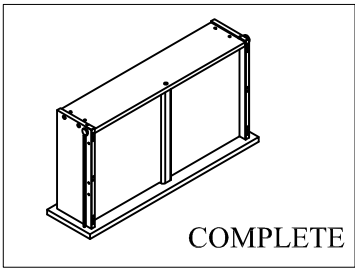

STEP 41

Étape

SCAN ME
SCANEZ-MOI



Assembly Video
Vidéo d'assemblage

		02
		01

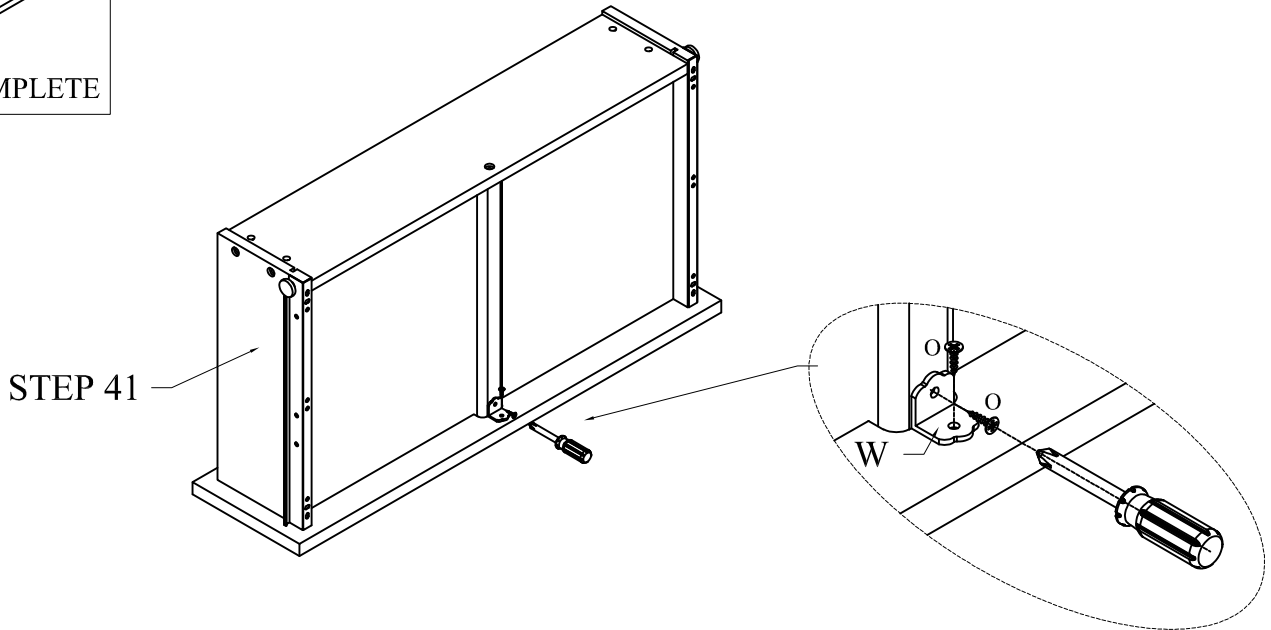
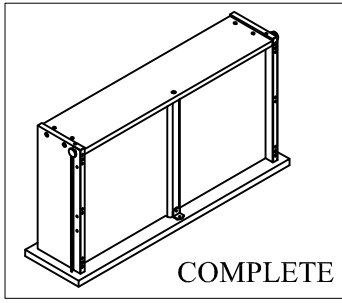

STEP 42

Étape

SCAN ME
SCANEZ-MOI



Assembly Video
Vidéo d'assemblage

		01
--	--	----

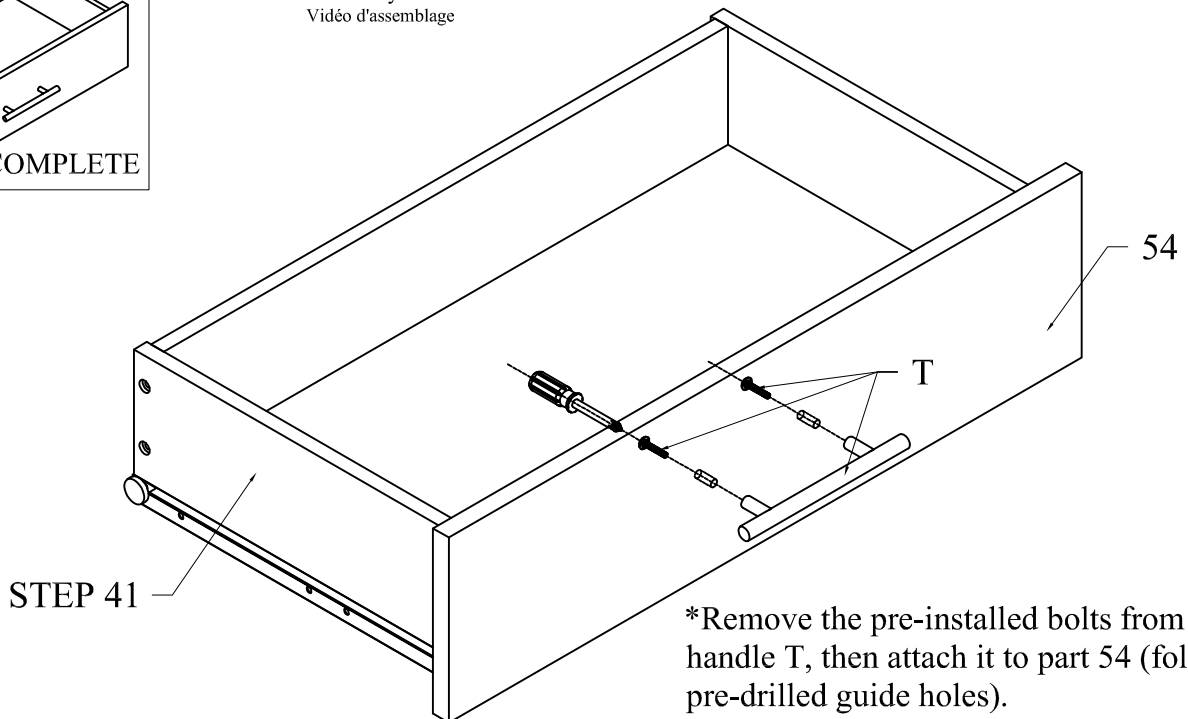
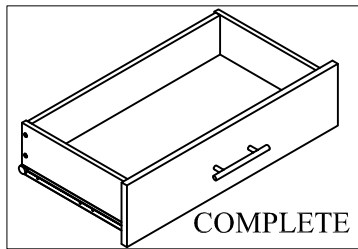

*Remove the pre-installed bolts from door handle T, then attach it to part 54 (following the pre-drilled guide holes).

*Retirez les boulons préinstallés sur la poignée de porte T, puis fixez-la à la pièce 54 (en suivant les trous de guidage prépercés).

STEP 43

Étape

SCAN ME
SCANEZ-MOI



Assembly Video
Vidéo d'assemblage

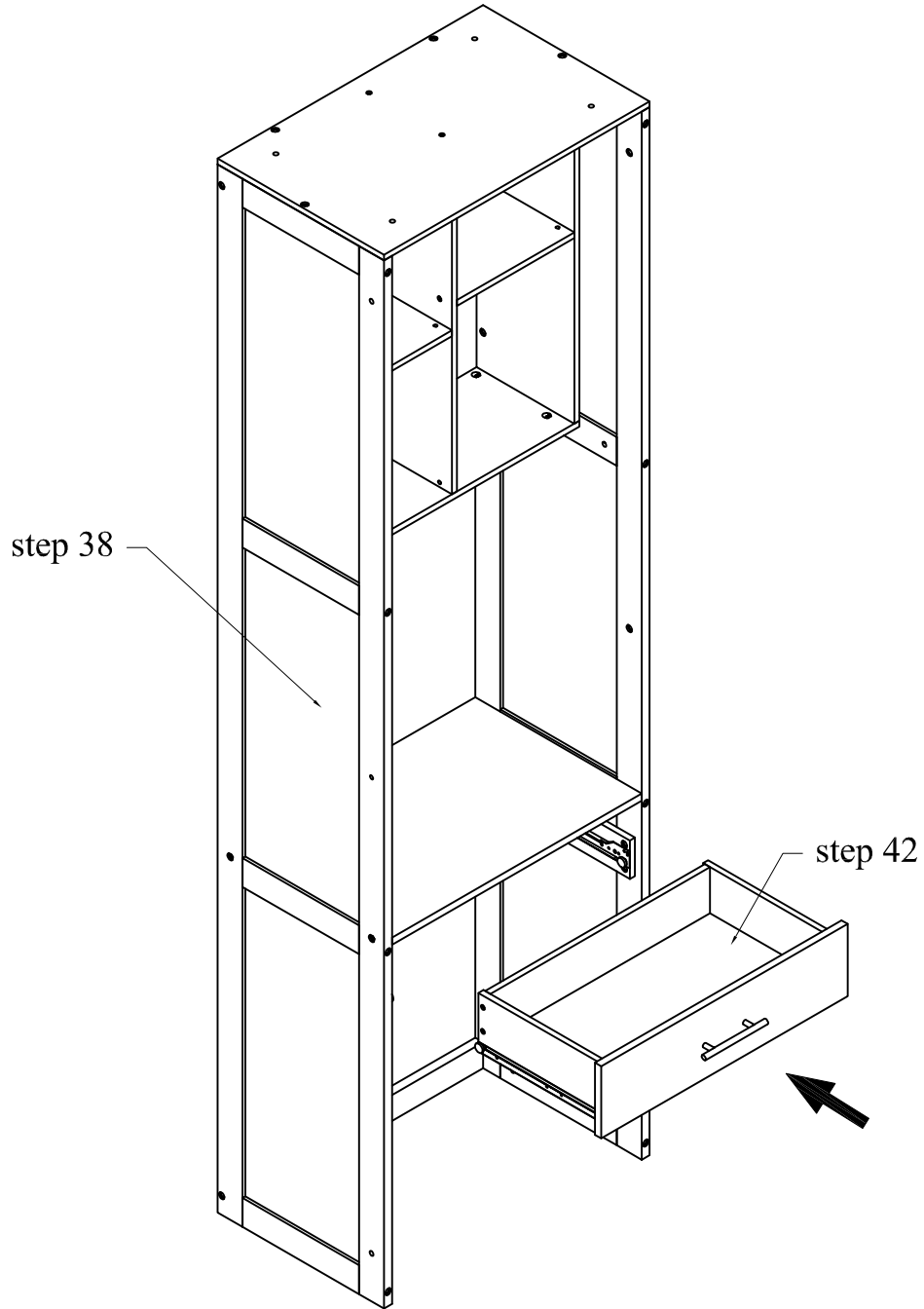
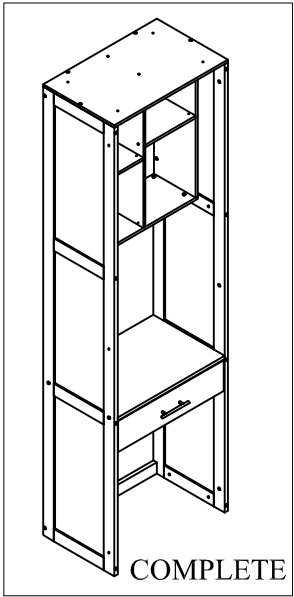

STEP 44

Étape

SCAN ME
SCANEZ-MOI



Assembly Video
Vidéo d'assemblage

©		06
---	--	----

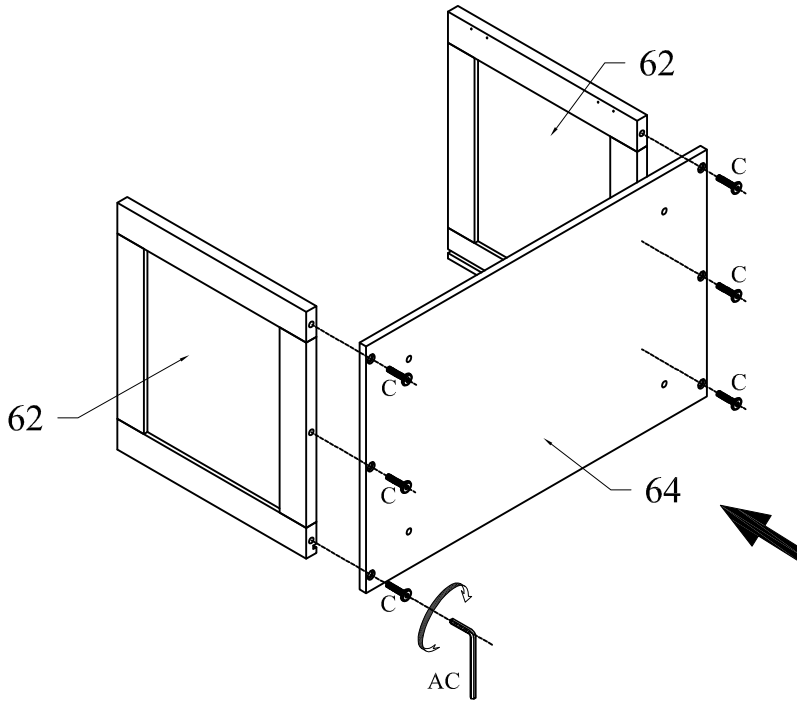
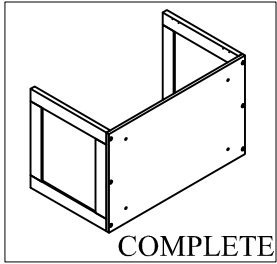

STEP 45

Étape

SCAN ME
SCANEZ-MOI



Assembly Video
Vidéo d'assemblage

©		06
---	--	----

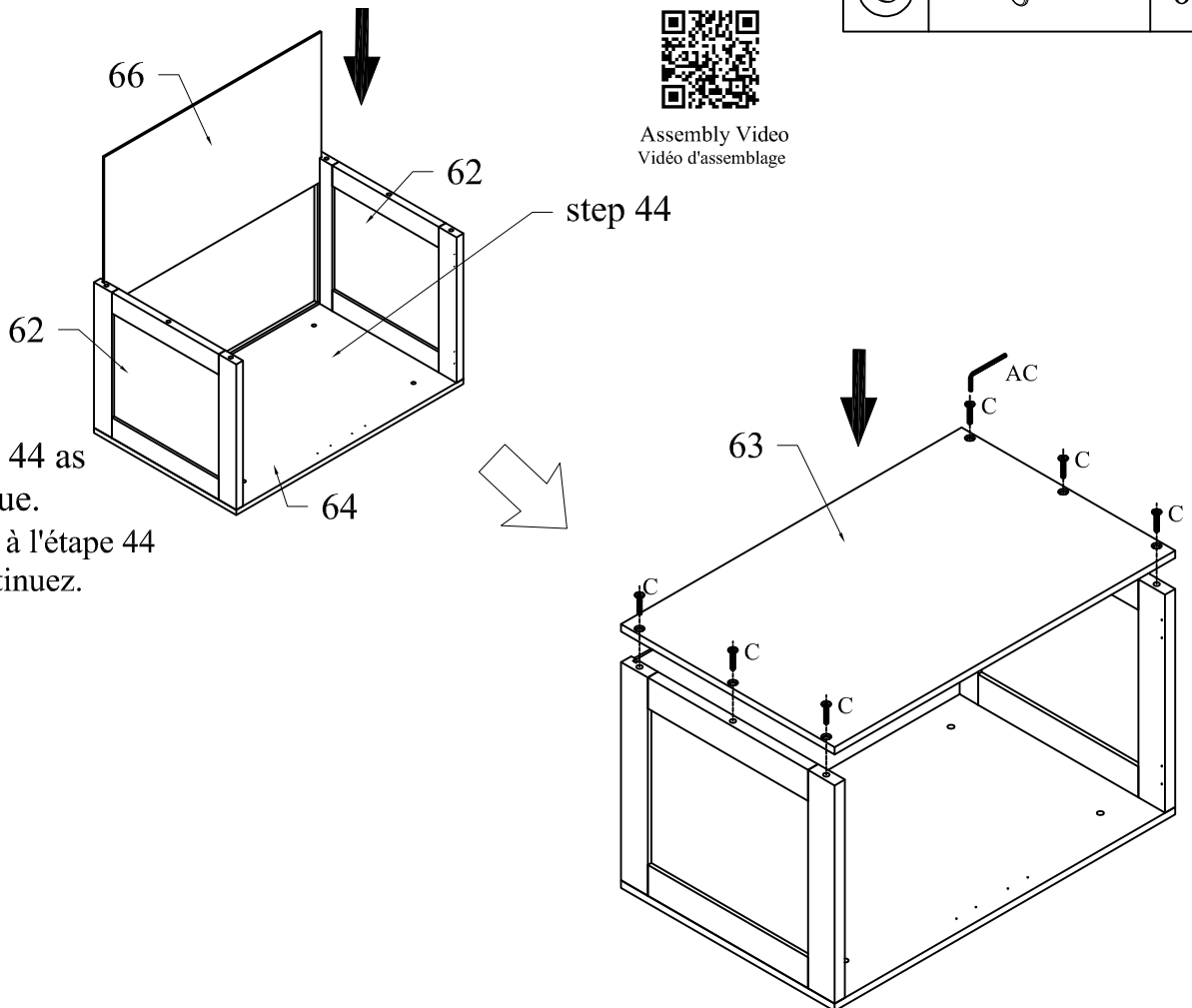
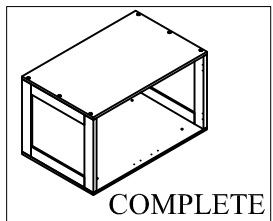

Flip the parts in Step 44 as described and continue.

Retournez les pièces à l'étape 44 comme décrit et continuez.

STEP 46

Étape

SCAN ME
SCANEZ-MOI



Assembly Video
Vidéo d'assemblage

(M)		04
(U)		02

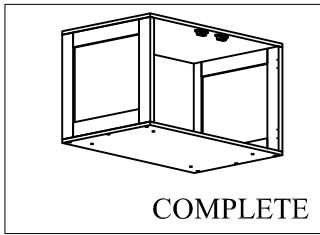

Assemble the door closer on the top surface of the cabinet using the pre-drilled guide holes.

Assemblez le ferme-porte sur la surface supérieure de l'armoire à l'aide des trous de guidage pré-perçés.

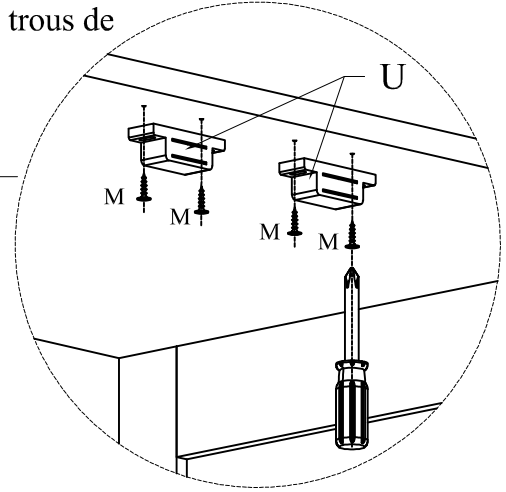
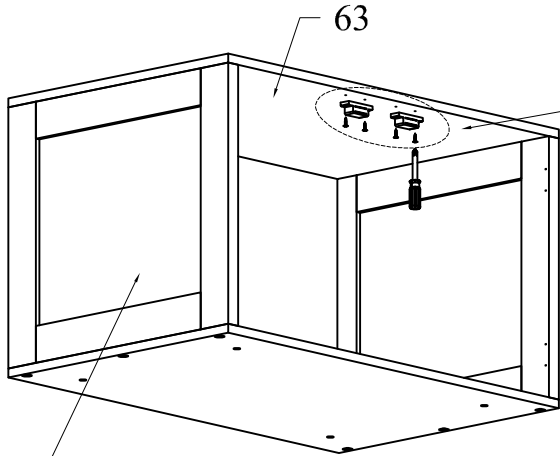

step 45

STEP 47

Étape

SCAN ME
SCANEZ-MOI



Assembly Video
Vidéo d'assemblage

(O)		04
(U)		02

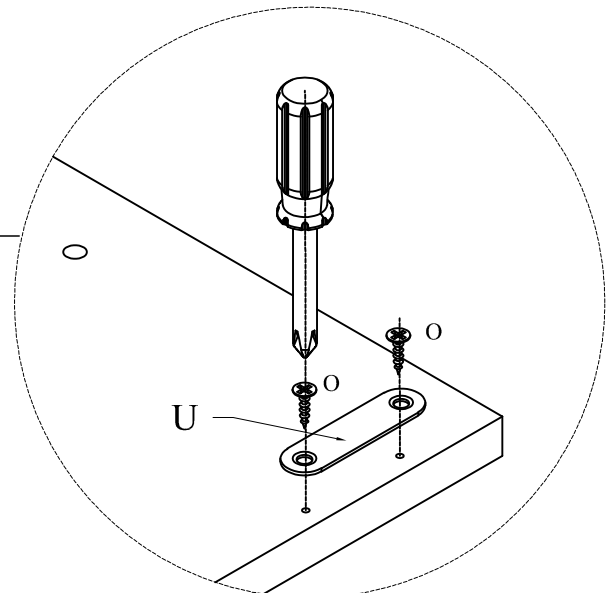
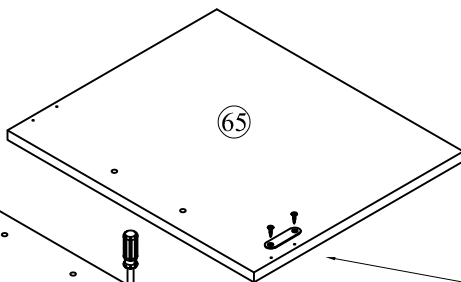
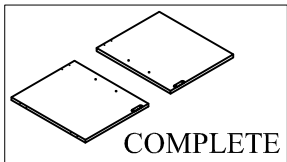

STEP 48

Étape

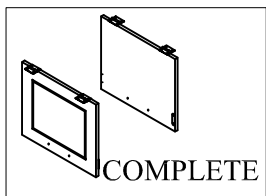

SCAN ME
SCANEZ-MOI



Assembly Video
Vidéo d'assemblage

(P)		08
(X)		04

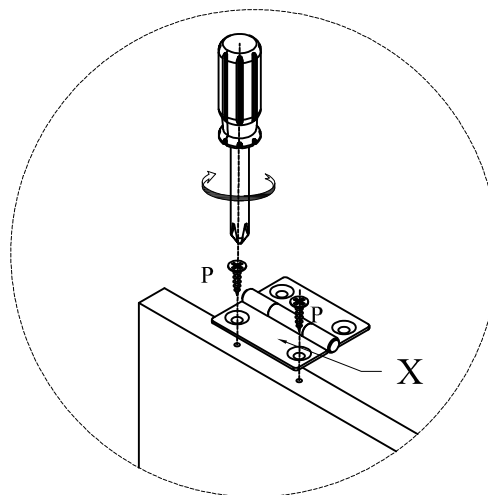
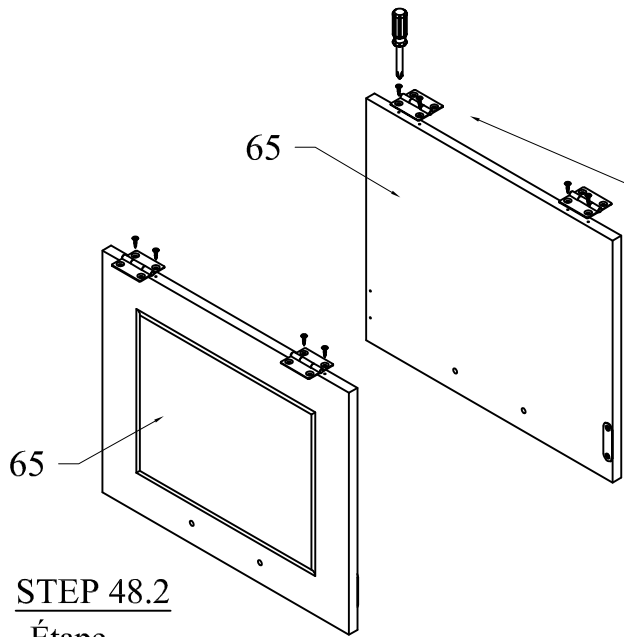

STEP 49

Étape

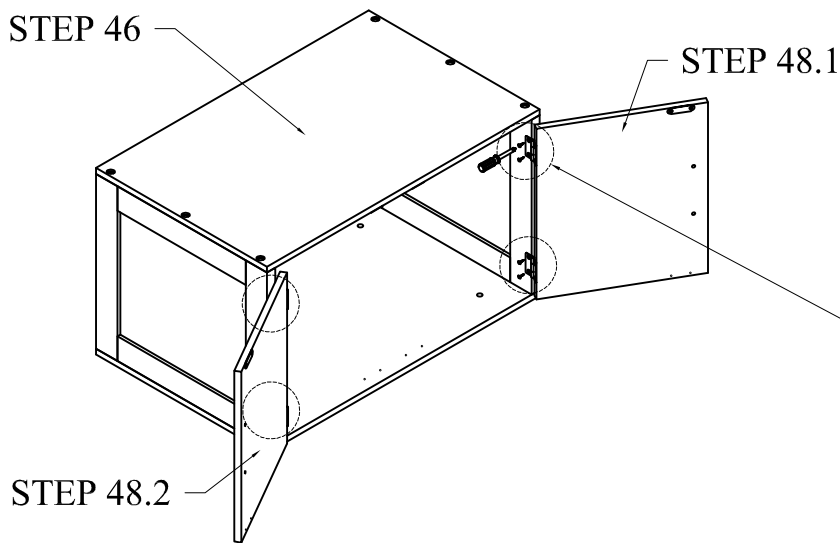

SCAN ME
SCANEZ-MOI



Assembly Video
Vidéo d'assemblage

(P)		08
-----	--	----

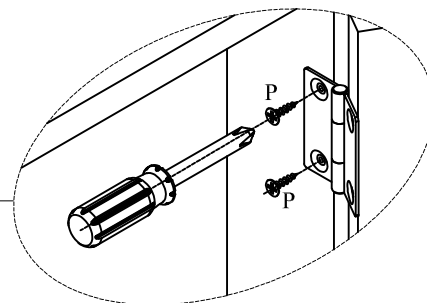

STEP 50

Étape

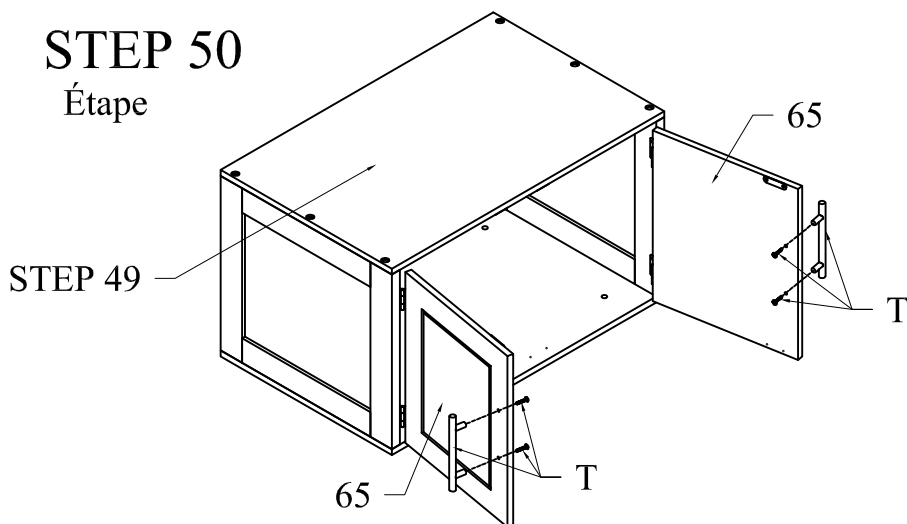

SCAN ME
SCANEZ-MOI



Assembly Video
Vidéo d'assemblage

(T)		02
-----	--	----

*Remove the pre-installed bolts from door handle T, then attach it to part 65 (following the pre-drilled guide holes).

*Retirez les boulons préinstallés sur la poignée de porte T, puis fixez-la à la pièce 65 (en suivant les trous de guidage prépercés).

STEP 51

Étape

SCAN ME
SCANEZ-MOI



Assembly Video
Vidéo d'assemblage



04

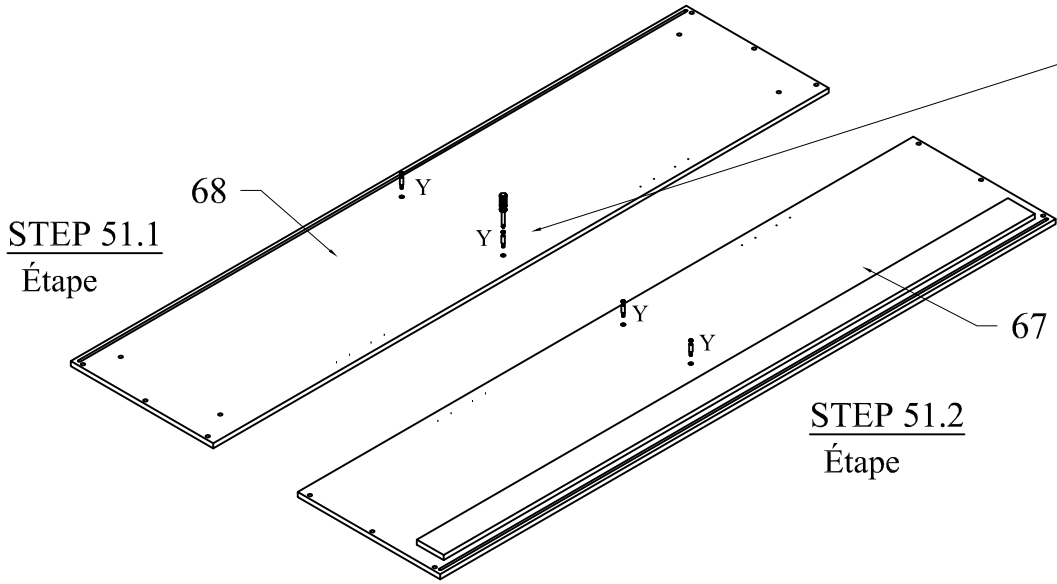
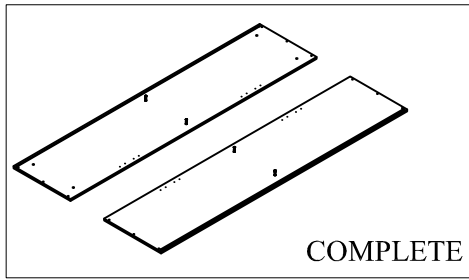

STEP 51.1

Étape

STEP 51.2

Étape

STEP 52

Étape

SCAN ME
SCANEZ-MOI



Assembly Video
Vidéo d'assemblage



06



02

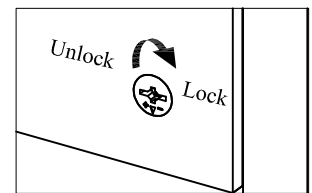
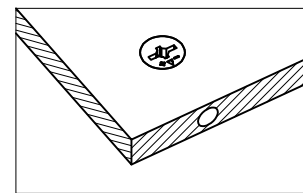
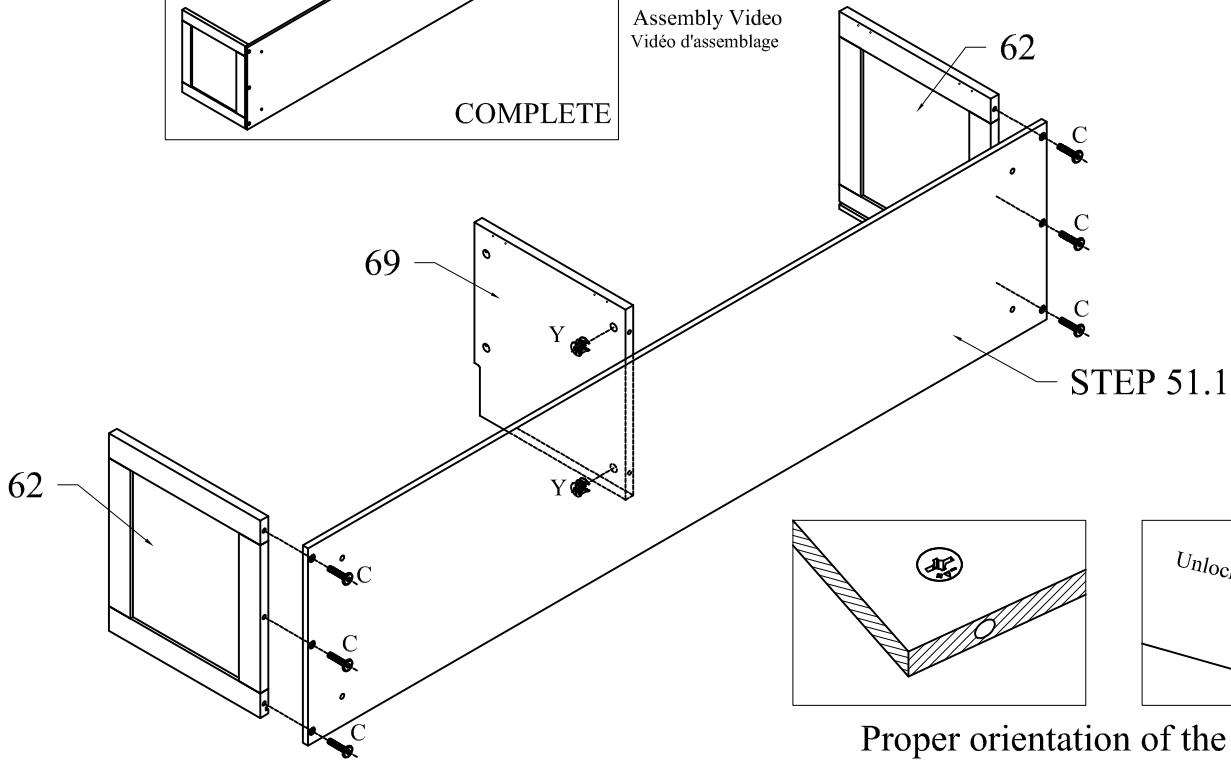
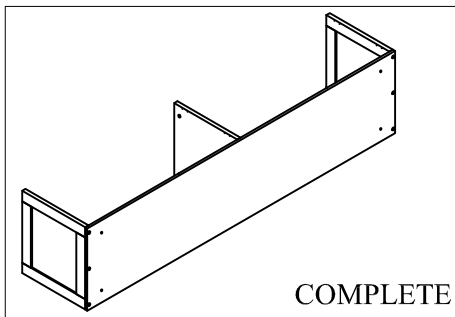

Proper orientation of the CAMLOCK
Sens d'installation correct du verrou à came

STEP 53

Étape

SCAN ME
SCANEZ-MOI



Assembly Video
Vidéo d'assemblage

(C)		06
(Y)		02

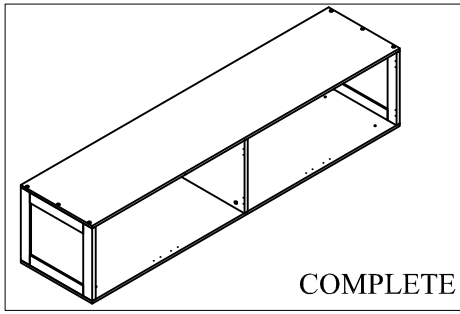

COMPLETE

Flip the parts in Step 52 as described and continue.

Retournez les pièces à l'étape 52 comme décrit et continuez.

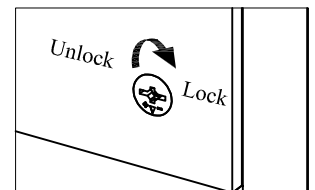
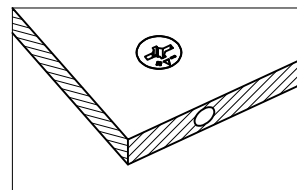
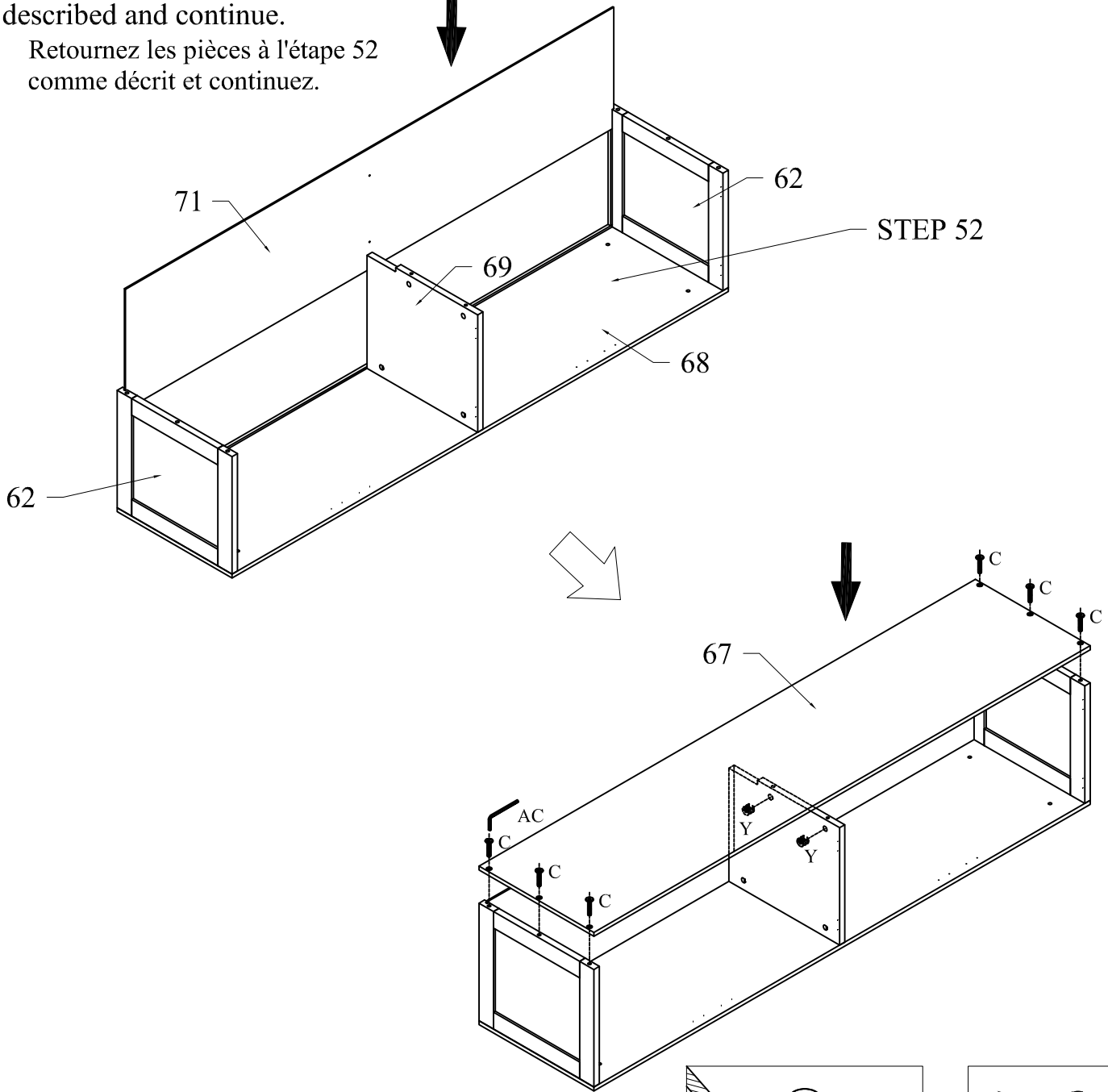

Proper orientation of the CAMLOCK
Sens d'installation correct du verrou à came

STEP 54

Étape

SCAN ME
SCANEZ-MOI



Assembly Video
Vidéo d'assemblage

(N)		02
-----	--	----

Flip the parts in Step 53 as described and continue.

Retournez les pièces à l'étape 53 comme décrit et continuez.

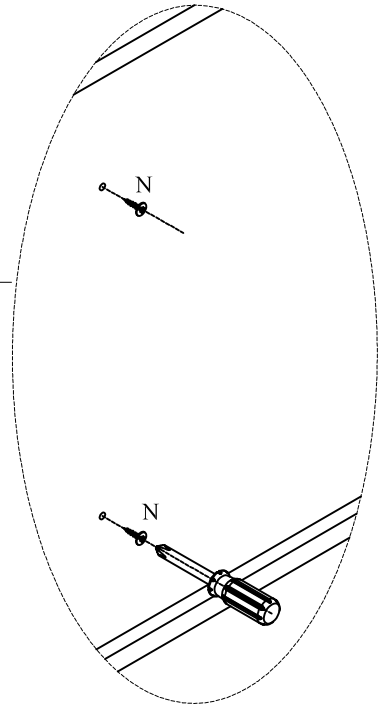
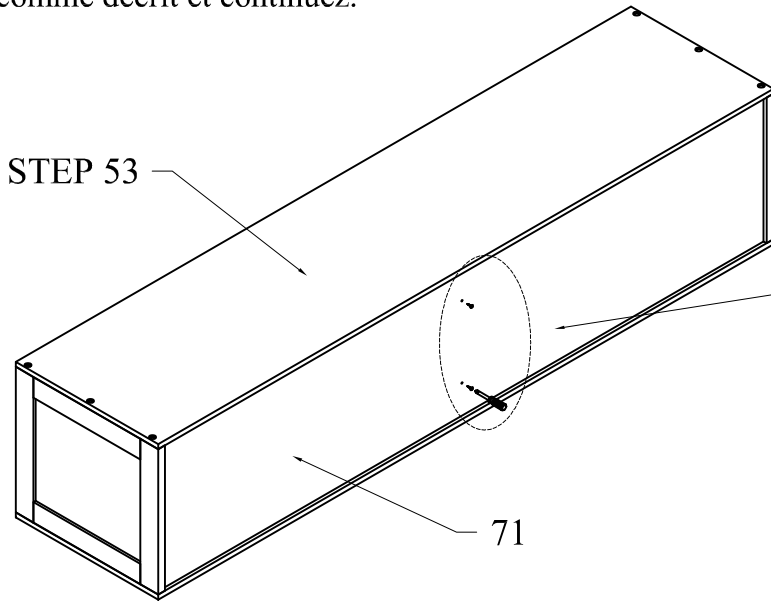

STEP 55

Étape

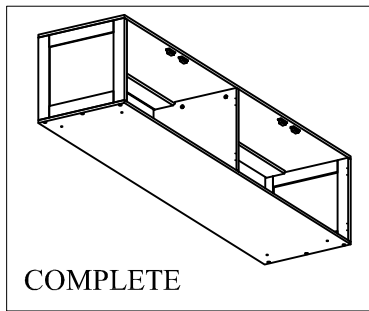

SCAN ME
SCANEZ-MOI



Assembly Video
Vidéo d'assemblage

(M)		08
(U)		04

Assemble the door closer on the top surface of the cabinet using the pre-drilled guide holes.

Assemblez le ferme-porte sur la surface supérieure de l'armoire à l'aide des trous de guidage pré-perçés.

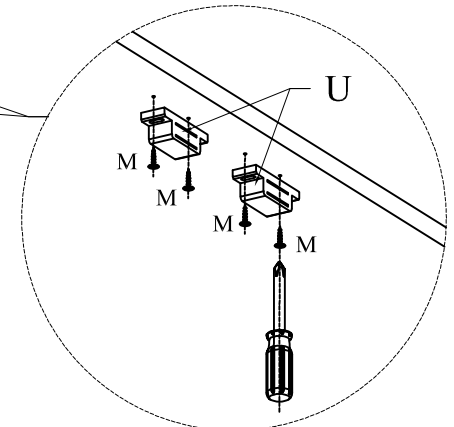
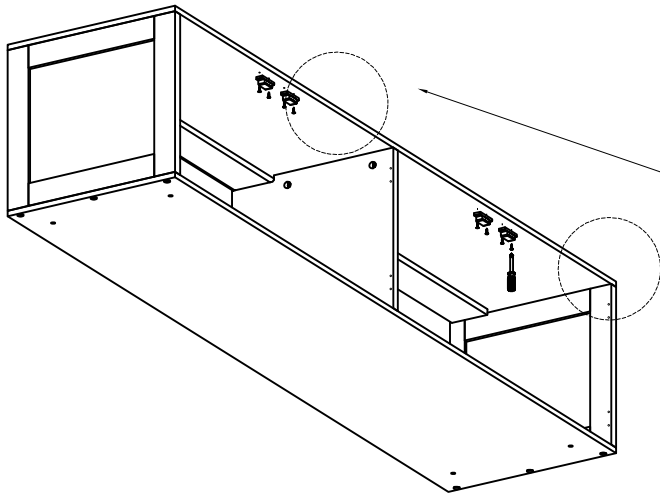

STEP 56

Étape

SCAN ME
SCANEZ-MOI



Assembly Video
Vidéo d'assemblage

O		08
U		04

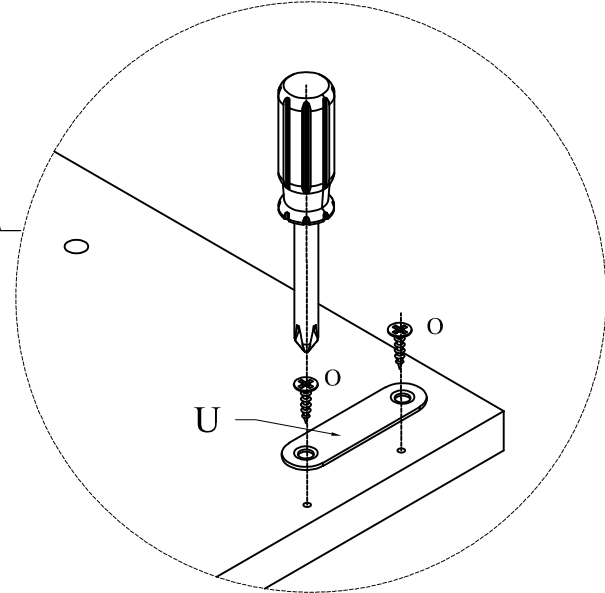
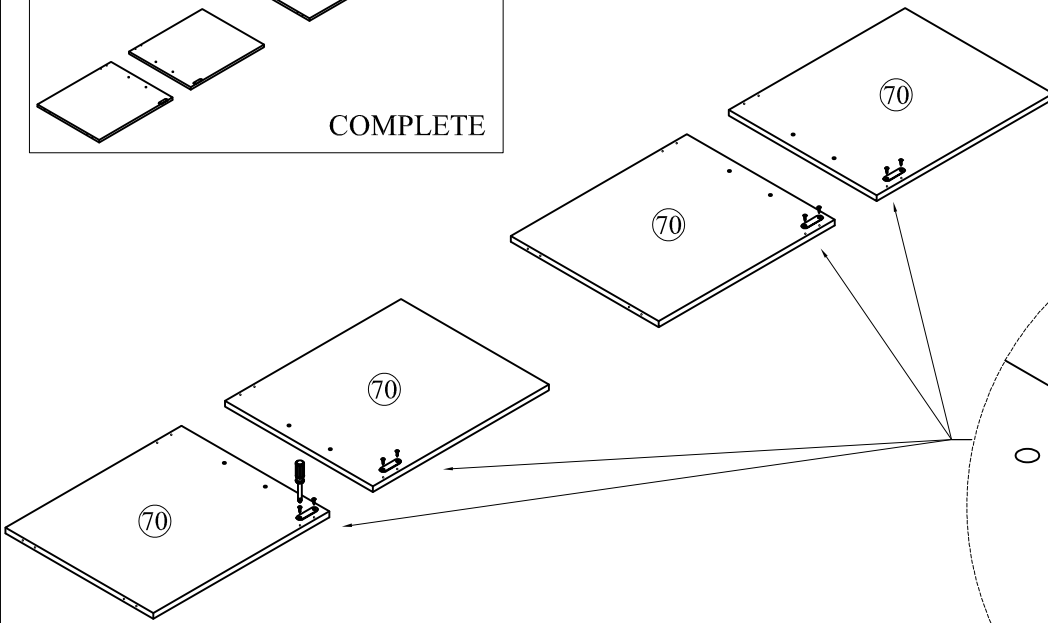
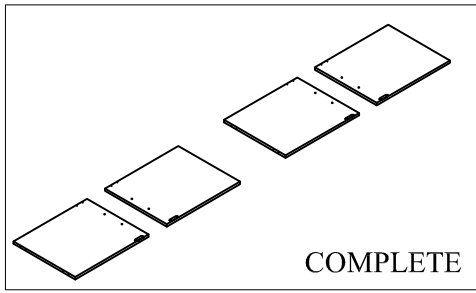

STEP 57

Étape

SCAN ME
SCANEZ-MOI



Assembly Video
Vidéo d'assemblage

P		16
X		08

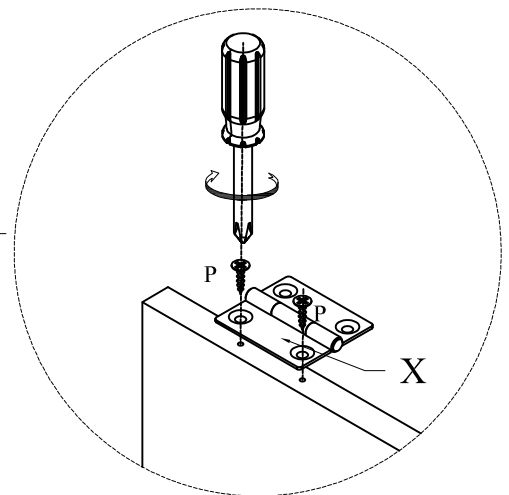
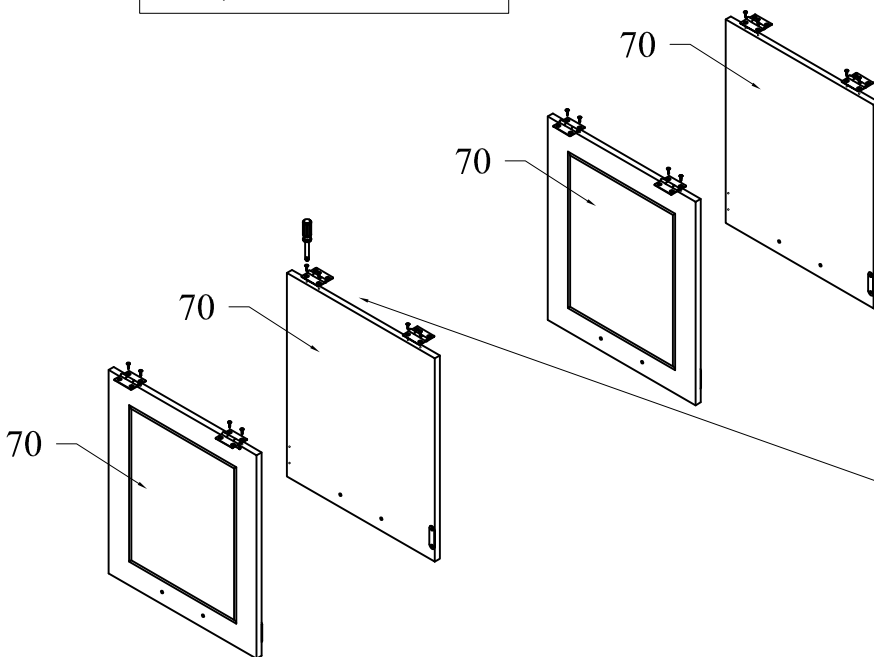
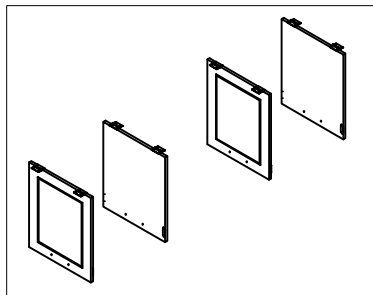

STEP 58

Étape

SCAN ME
SCANEZ-MOI



Assembly Video
Vidéo d'assemblage



16

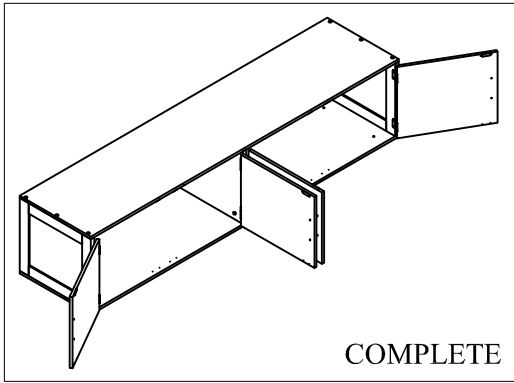

STEP 55

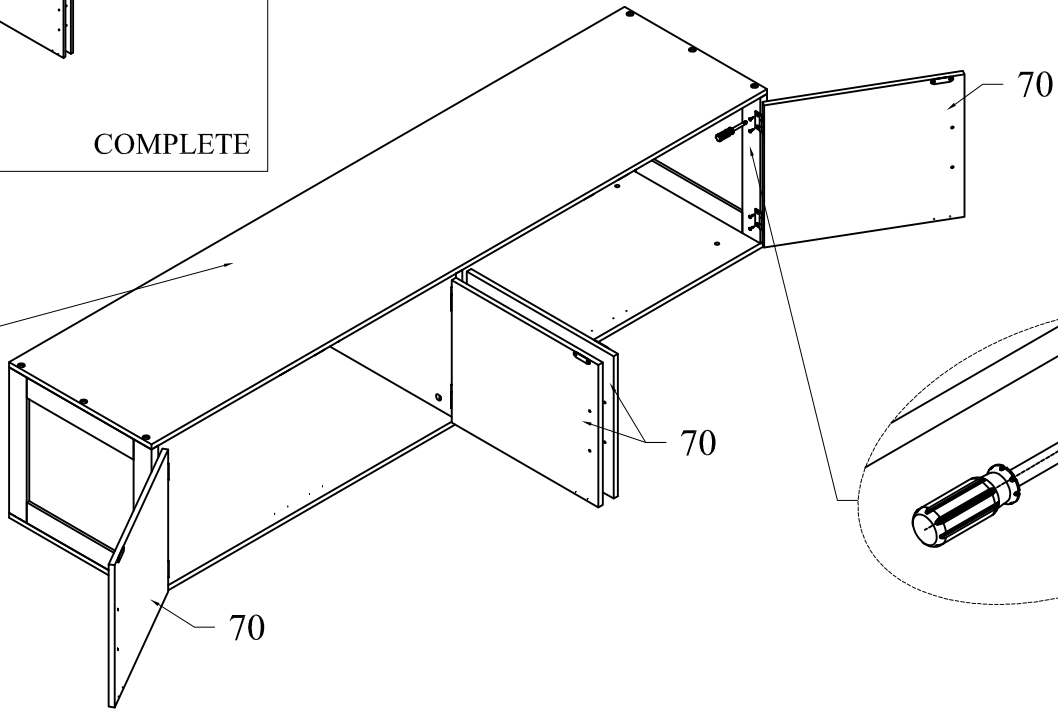

STEP 59

Étape

SCAN ME
SCANEZ-MOI



Assembly Video
Vidéo d'assemblage

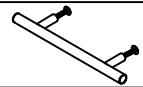

04

STEP 58

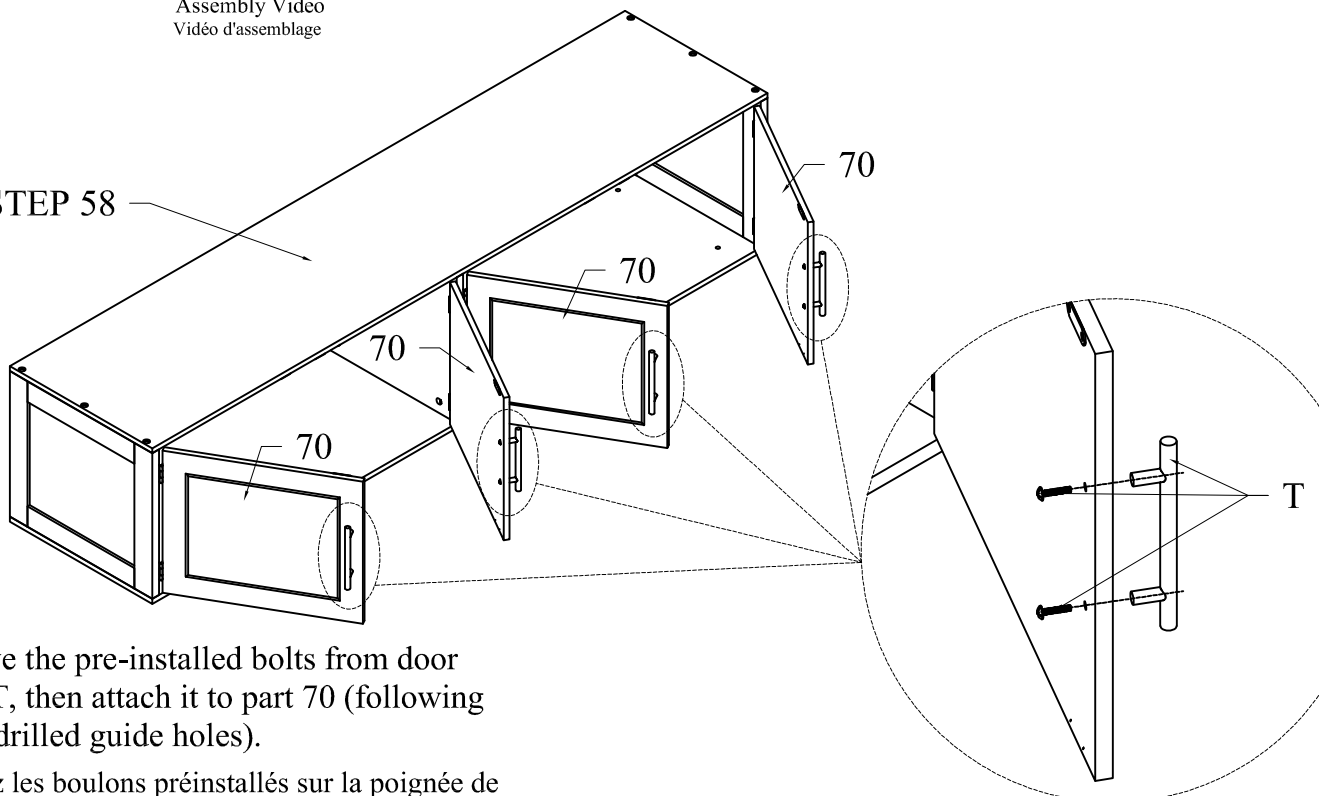

*Remove the pre-installed bolts from door handle T, then attach it to part 70 (following the pre-drilled guide holes).

*Retirez les boulons préinstallés sur la poignée de porte T, puis fixez-la à la pièce 70 (en suivant les trous de guidage prépercés).

STEP 60

Étape

SCAN ME
SCANEZ-MOI



Assembly Video
Vidéo d'assemblage

(B)		04
(L)		04

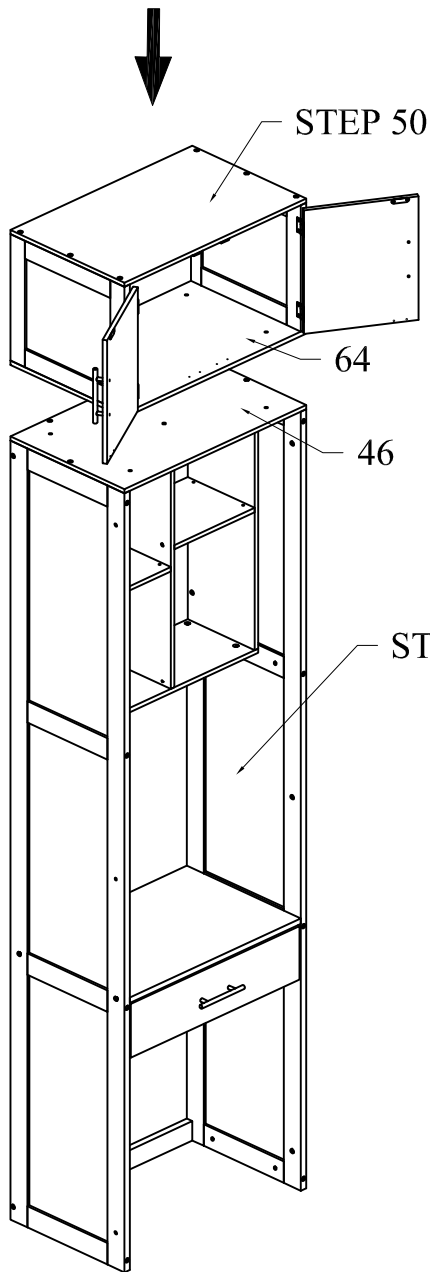

Use four B and L hardware pieces to attach the upper and lower cabinets together.

Utilisez quatre pièces de quincaillerie B et L pour fixer les armoires supérieure et inférieure ensemble.

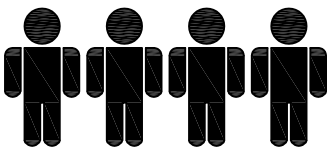
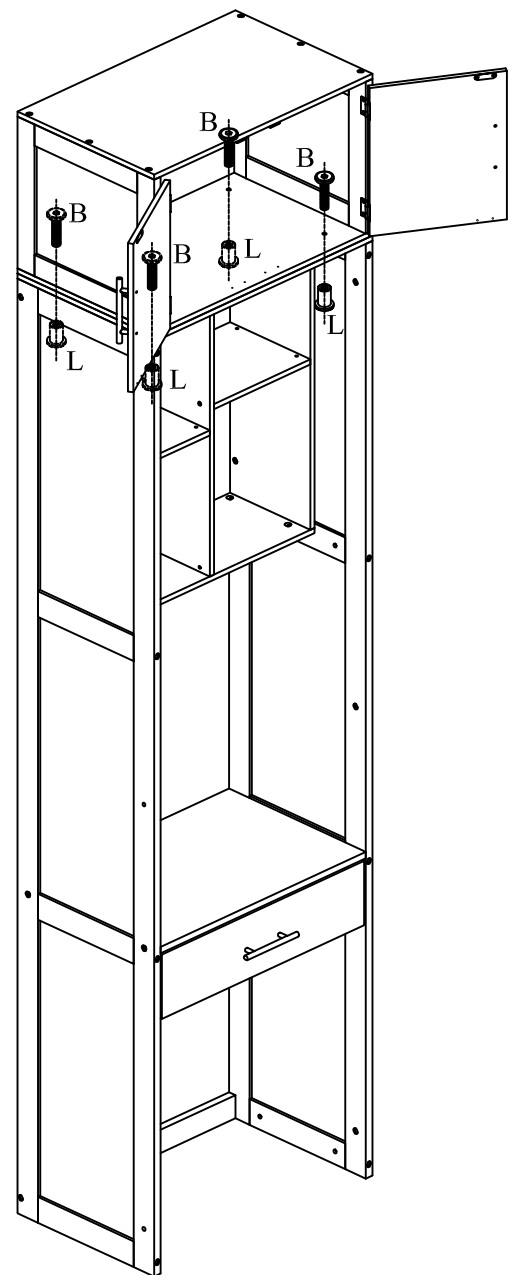

Four people are required to assemble and move this model

Quatre personnes sont nécessaires pour assembler et déplacer ce modèle

STEP 61

Étape

SCAN ME
SCANEZ-MOI



Assembly Video
Vidéo d'assemblage

(B)		04
(L)		04

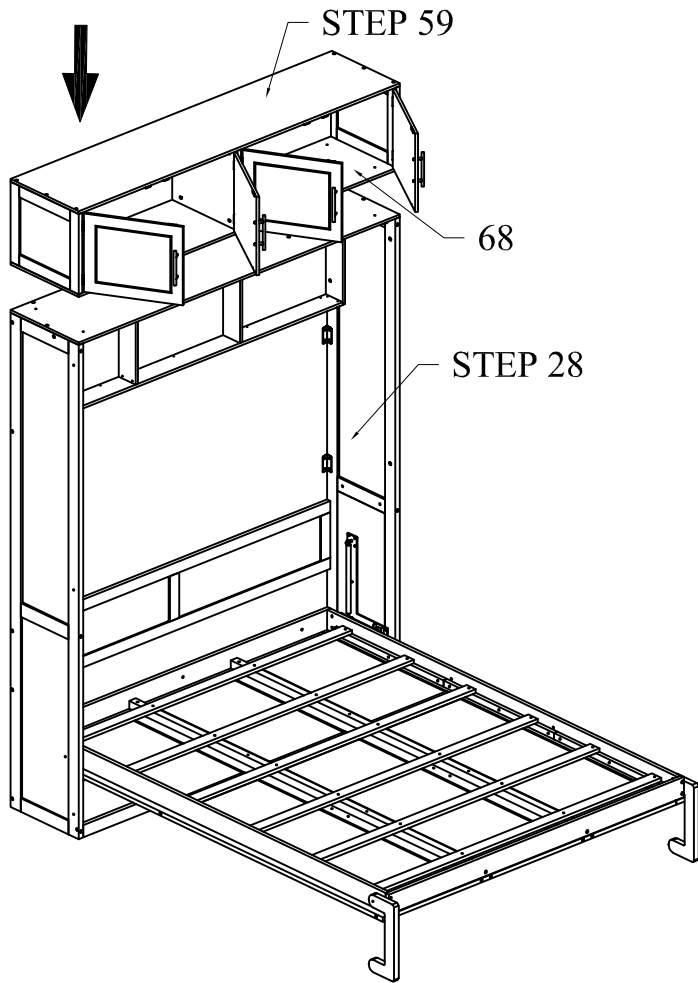

Use four B and L hardware pieces to attach the upper cabinet to the bed section below.

Utilisez quatre pièces de quincaillerie B et L pour fixer l'armoire supérieure à la section de lit ci-dessous.

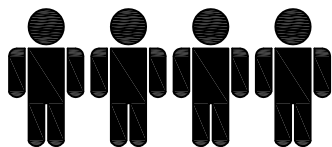
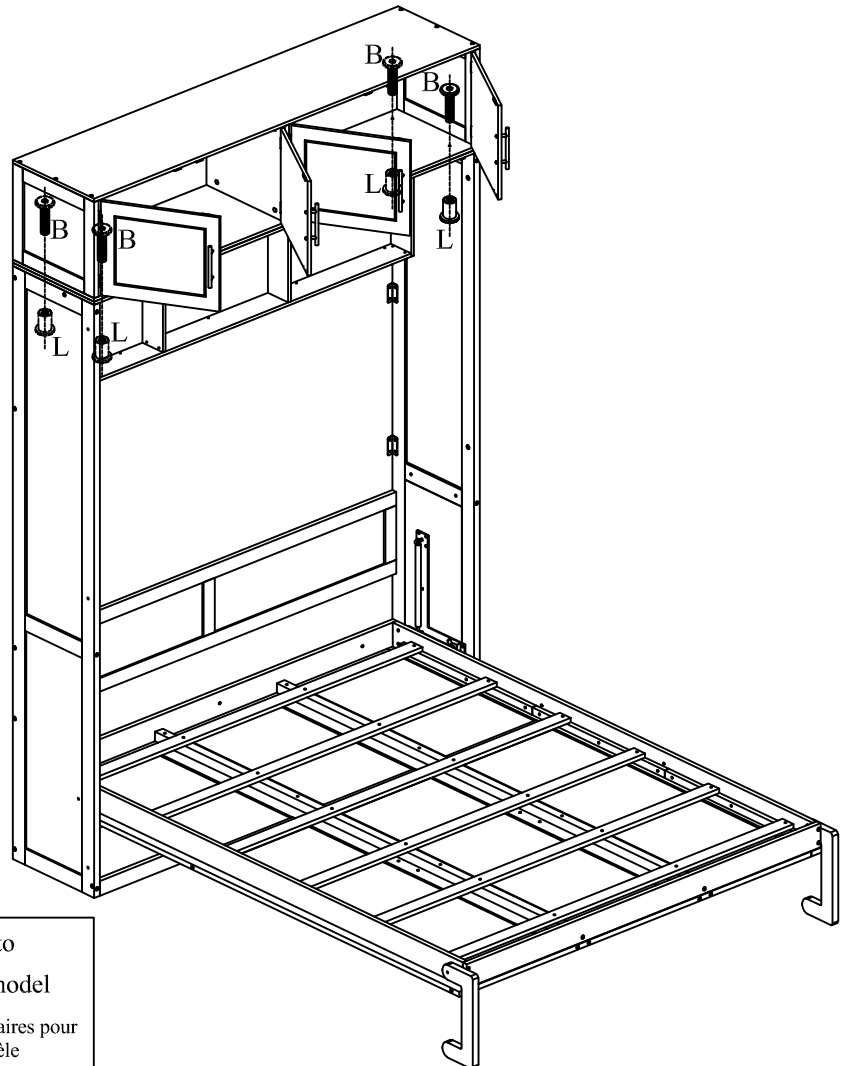

Four people are required to assemble and move this model

Quatre personnes sont nécessaires pour assembler et déplacer ce modèle

STEP 62

Étape

SCAN ME
SCANEZ-MOI



Assembly Video
Vidéo d'assemblage

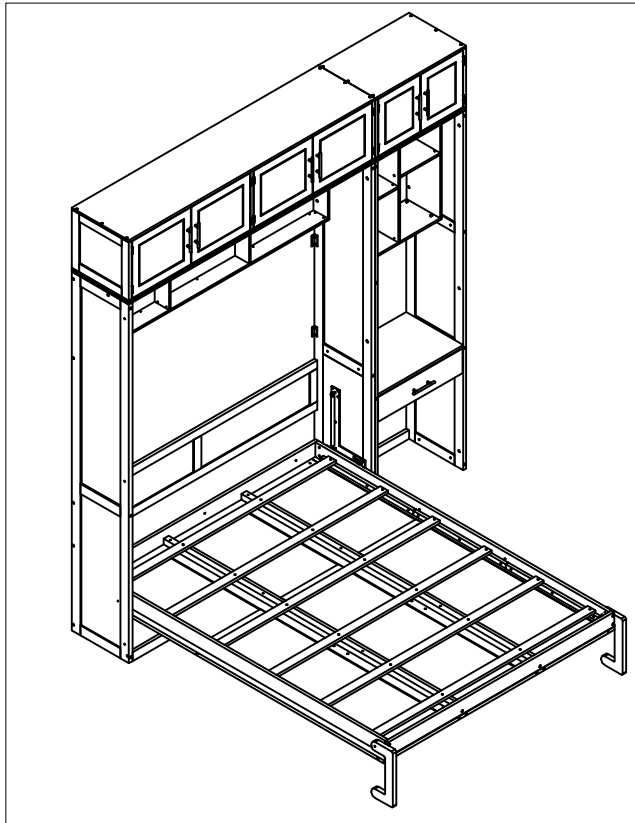

Note: Depending on the intended use, the cabinet can be installed on either the left or right side of the bed.

Remarque : Selon l'utilisation prévue, le meuble peut être installé du côté gauche ou droit du lit.

STEP 61

STEP 60

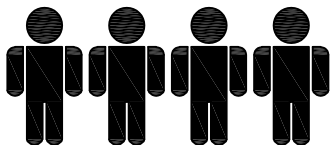
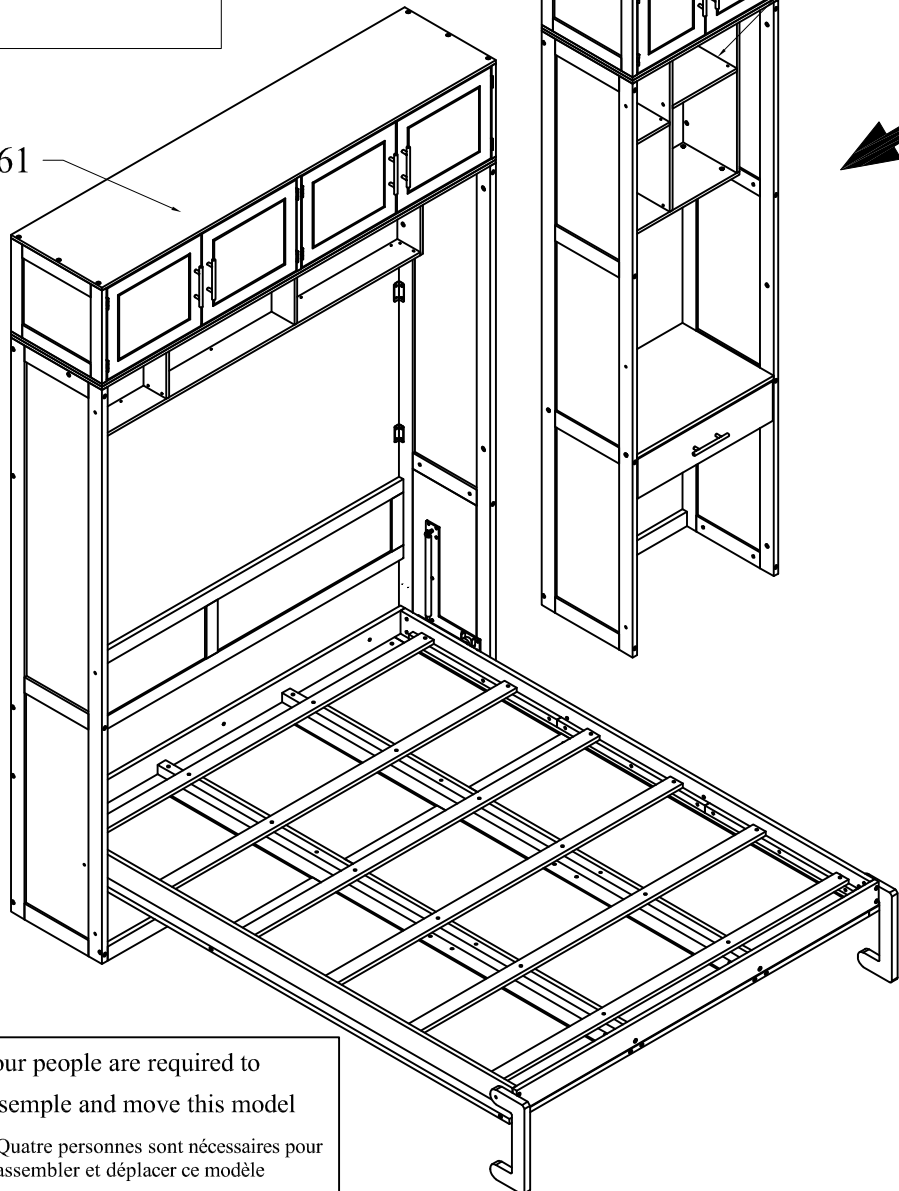

Four people are required to assemble and move this model

Quatre personnes sont nécessaires pour assembler et déplacer ce modèle



STEP 63

Étape

SCAN ME
SCANEZ-MOI



Assembly Video
Vidéo d'assemblage

AF		03
L		03

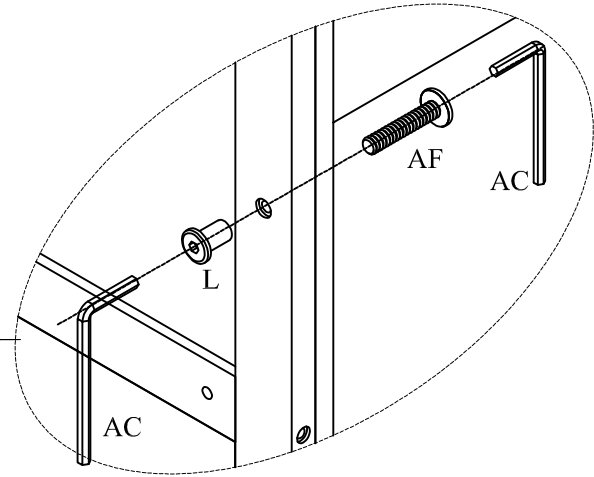
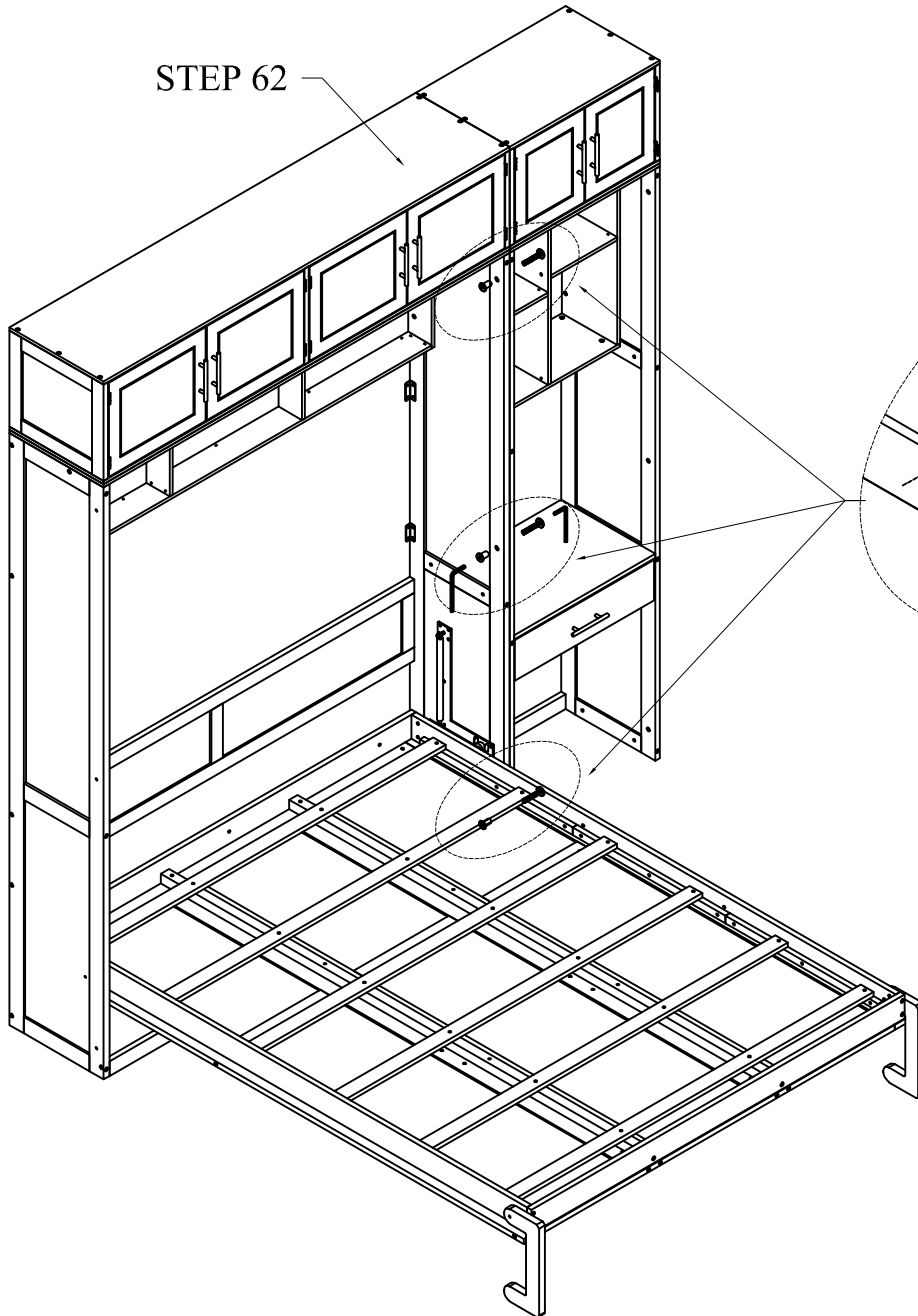

WALL ANCHORING INSTRUCTIONS

INSTRUCTIONS D'ANCRAGE MURAL

- 1** Place the PATT L (V) on top of the shelf and mark the positions to be drilled into the wall (8 holes).

Placez le PATT L (V) sur le dessus de l'étagère et marquez les emplacements à percer dans le mur (8 trous).

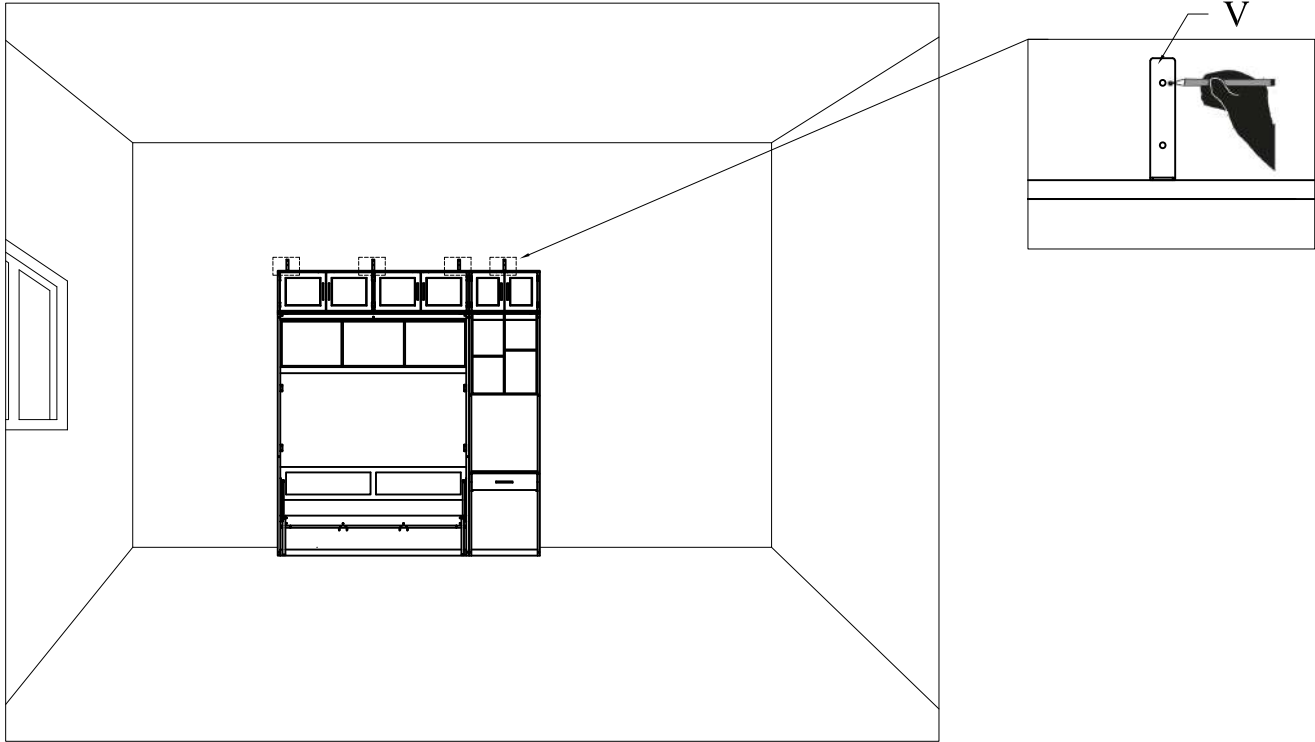

- 2** Move the patts to another position, then use a wall drill with an 8mm drill bit to drill into the marked positions, ensuring the hole depth exceeds 50mm.

Déplacez les pattes vers une autre position, puis utilisez une perceuse murale avec un foret de 8 mm pour percer les positions marquées, en vous assurant que la profondeur du trou dépasse 50 mm.

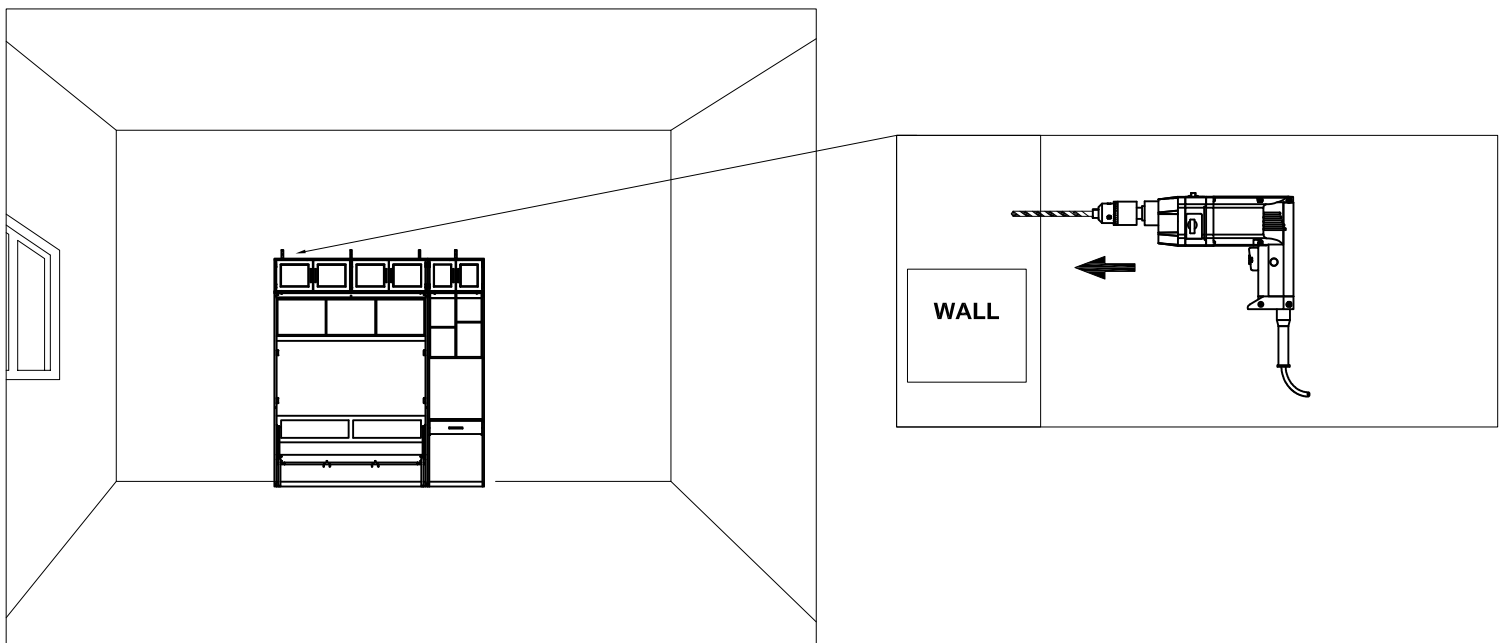

3

Insert plastic stopper (Z) into the drilled holes on the wall.
Insérez le bouchon en plastique (Z) dans les trous percés sur le mur.

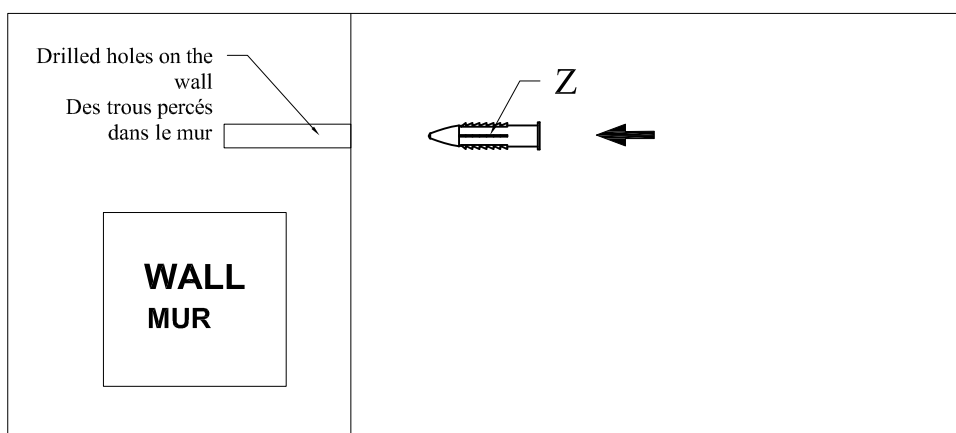

4

Put the patt back in its place. Use screws to securely attach the bed to the wall.
Remettez le support en place. Fixez solidement le lit au mur à l'aide de vis.

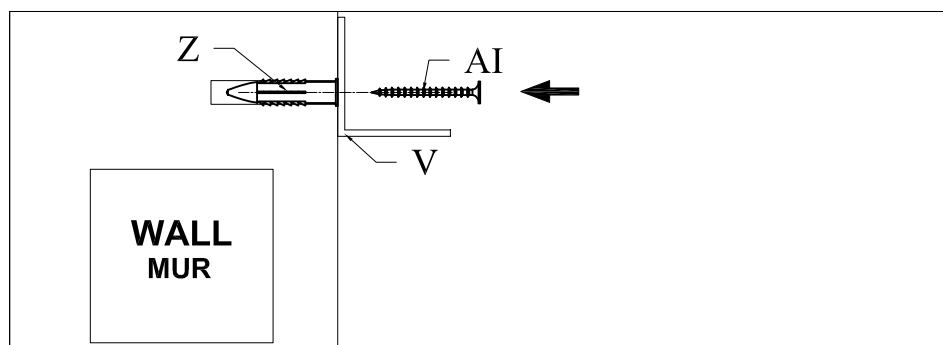

STEP 64

Étape

SCAN ME
SCANEZ-MOI



Assembly Video
Vidéo d'assemblage



08

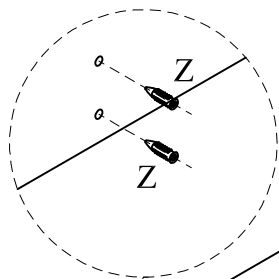

WALL

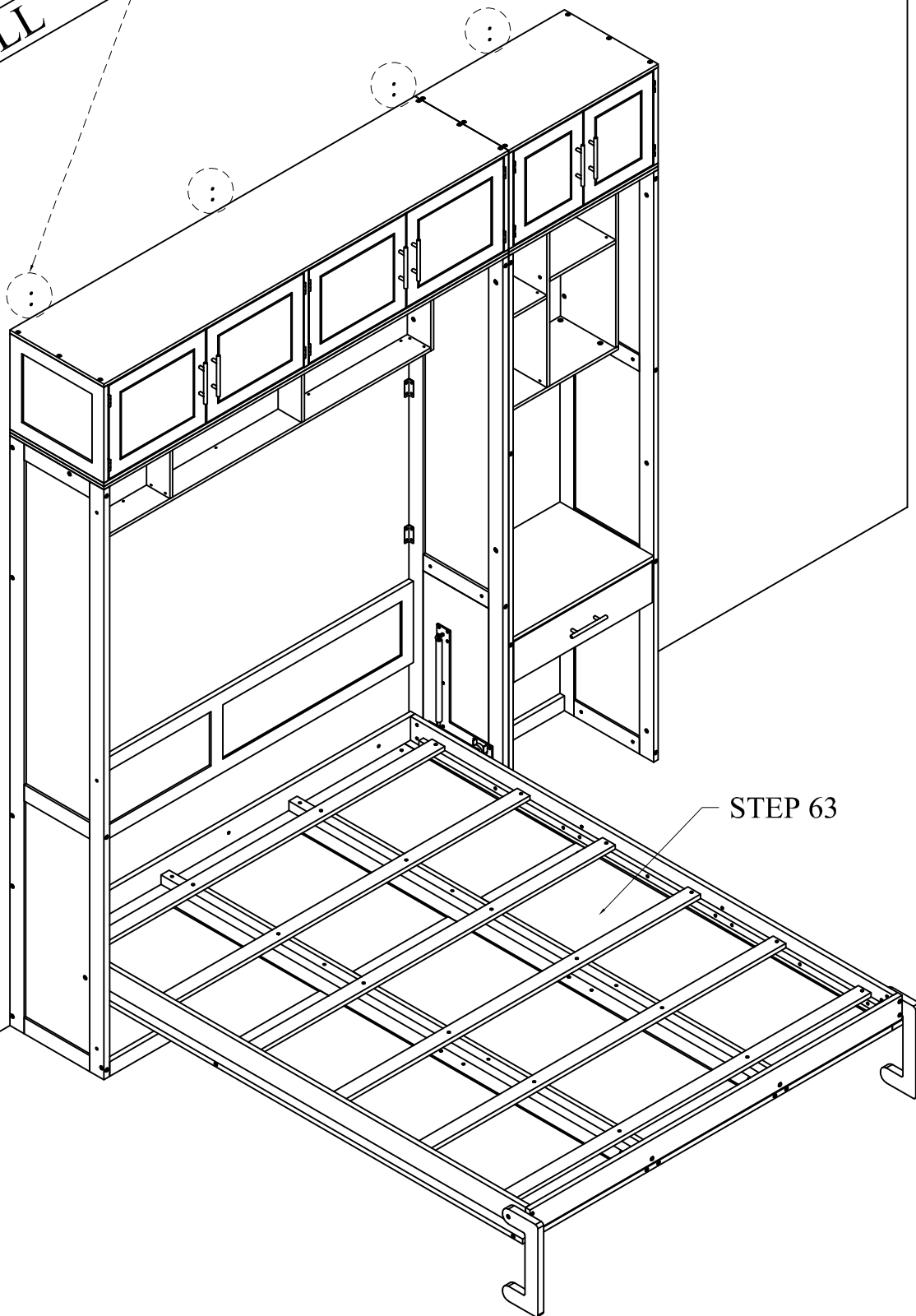

STEP 63

STEP 65

Étape

SCAN ME
SCANEZ-MOI



Assembly Video
Vidéo d'assemblage

Q		08
AI		08
V		04
AD		70

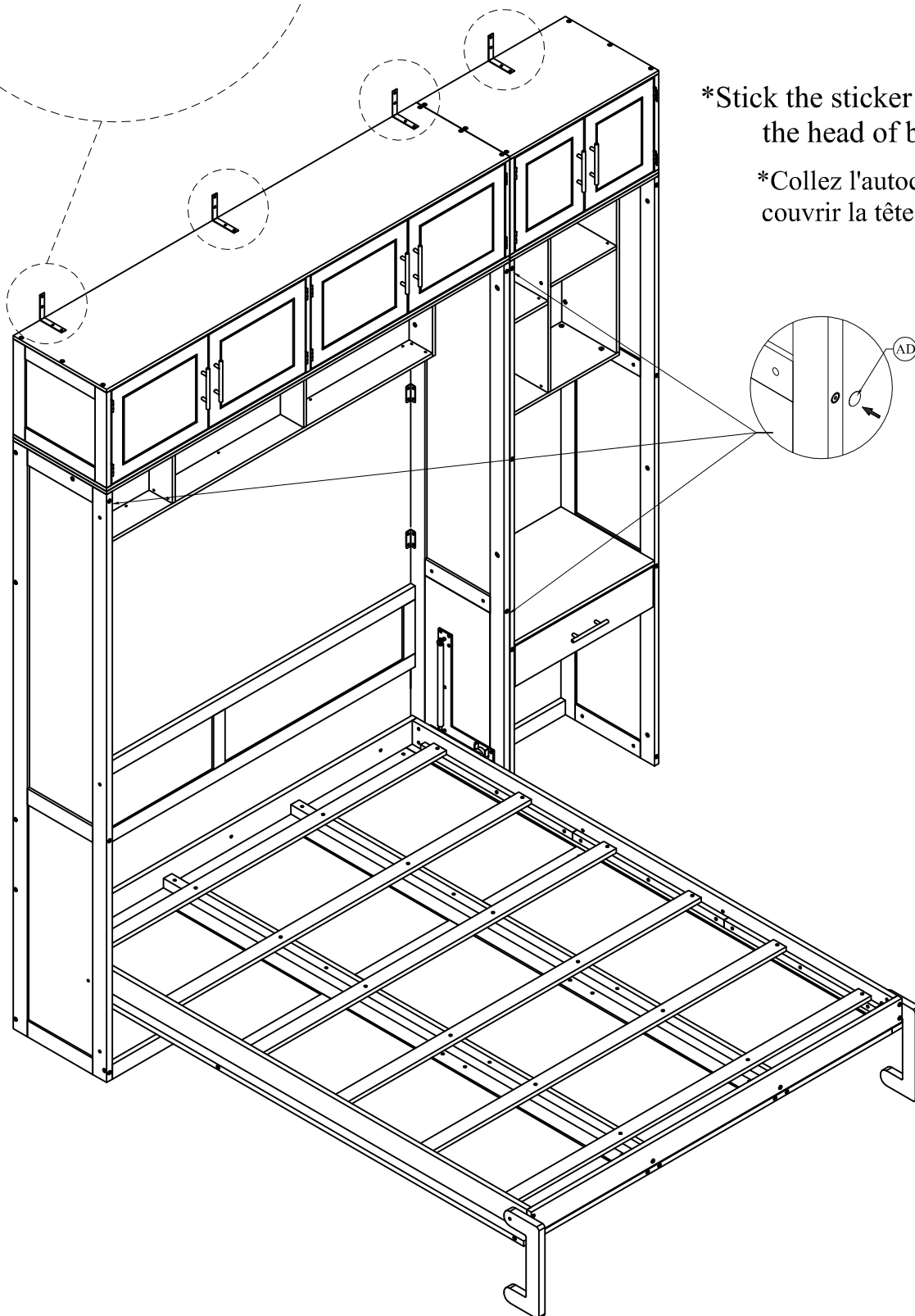
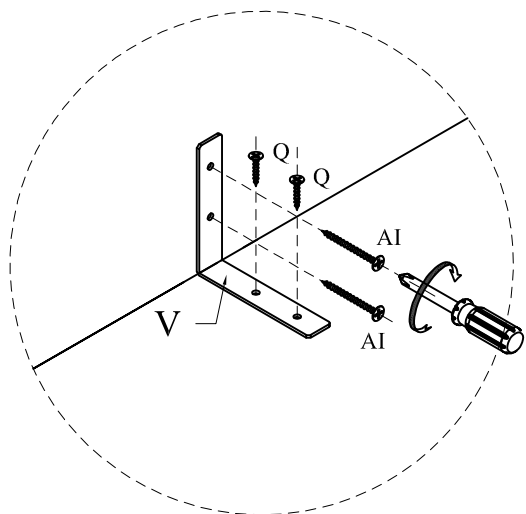

*Stick the sticker to cover the head of bolt.

*Collez l'autocollant pour couvrir la tête du boulon.

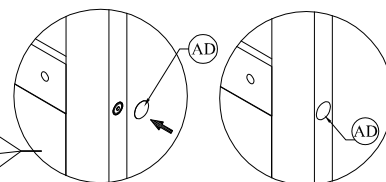

STEP 66

Étape

SCAN ME
SCANEZ-MOI



Assembly Video
Vidéo d'assemblage

P		12
AH		02

*Attach the door latch to parts 1, 22, 23, and 2 using the pre-drilled guide holes.

*Fixez le verrou de porte sur les pièces 1, 22, 23 et 2 en utilisant les trous de guidage pré-perçés.

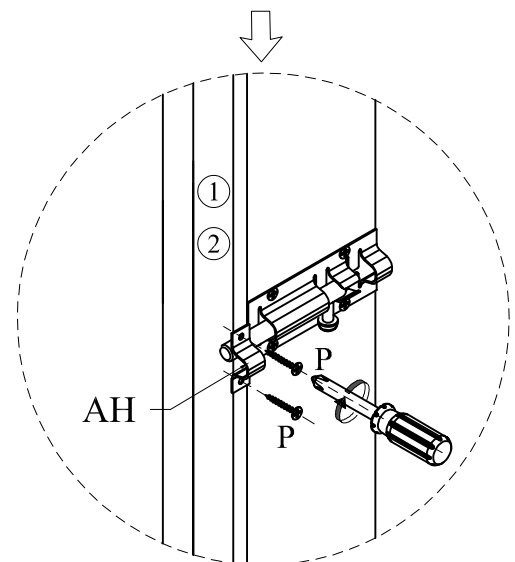
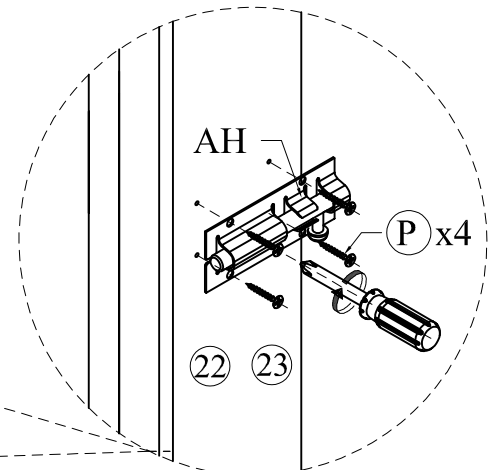
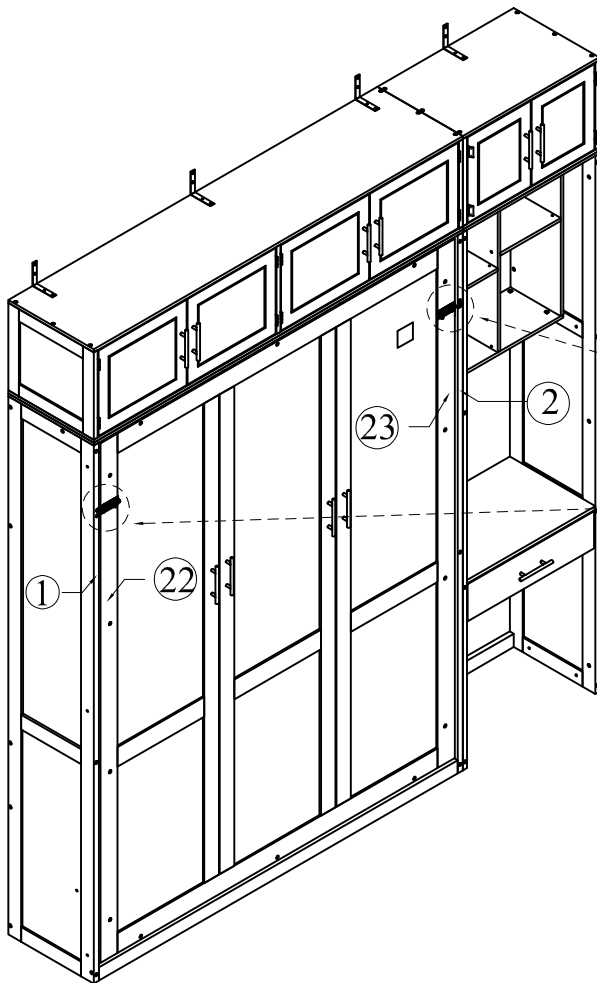
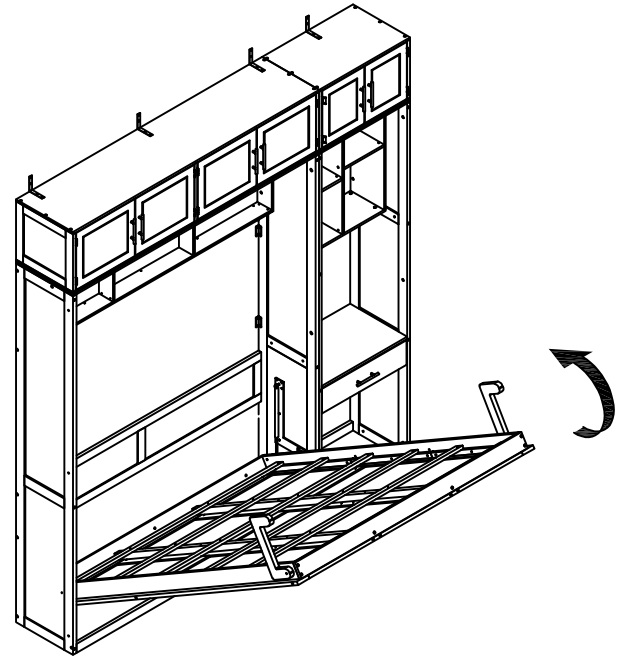

STEP 67

Étape

SCAN ME
SCANEZ-MOI



Assembly Video
Vidéo d'assemblage

Unlock

Ouvrir

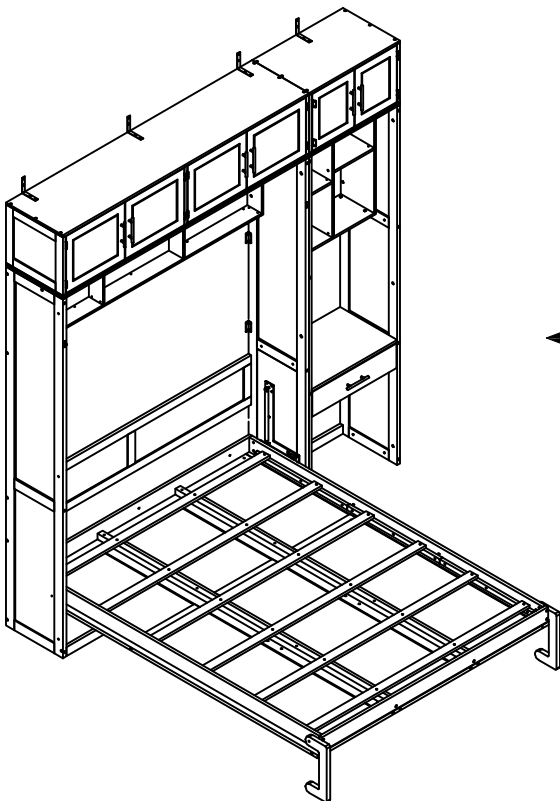
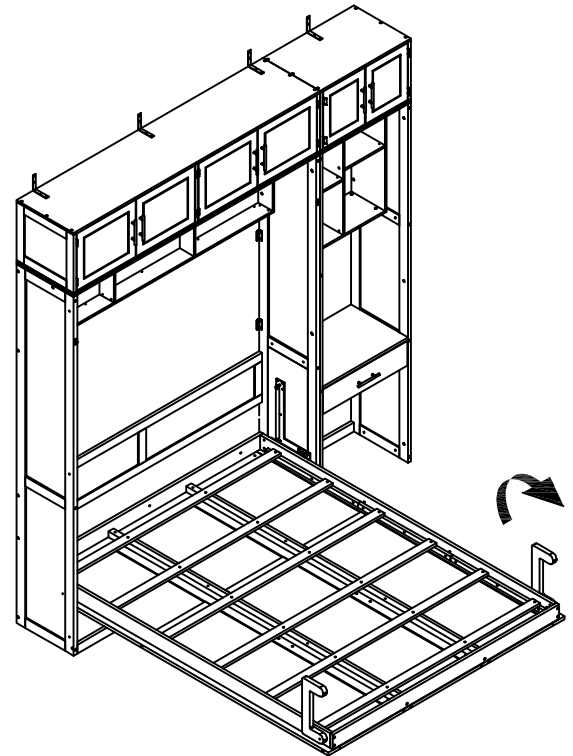
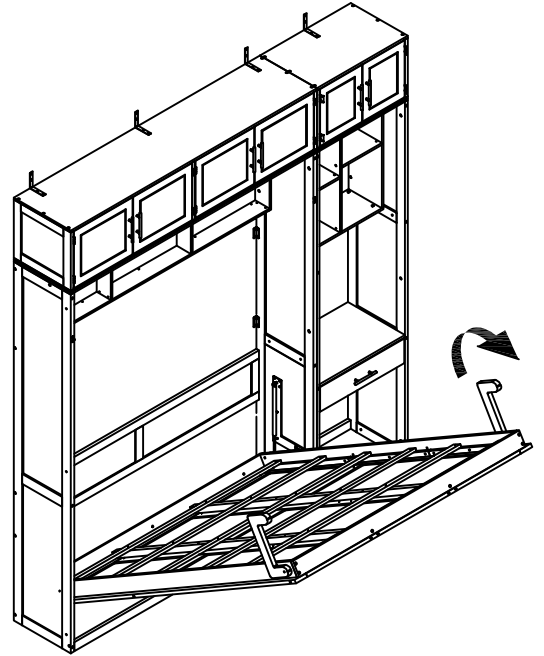
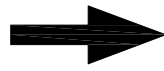
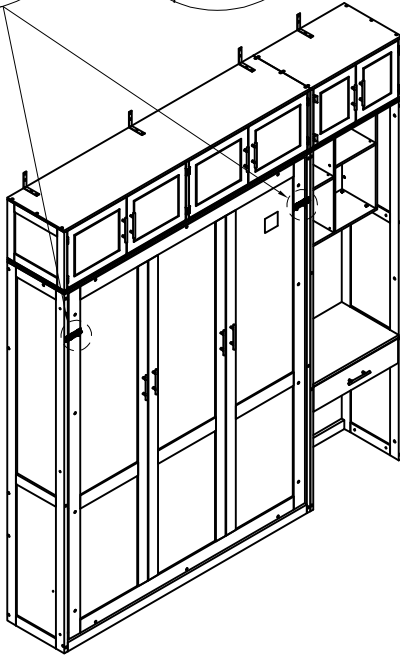
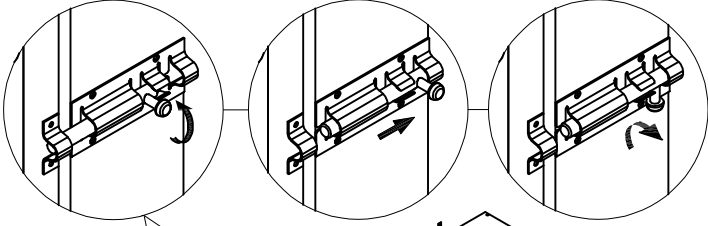

STEP 68

Étape

SCAN ME
SCANEZ-MOI



Assembly Video
Vidéo d'assemblage

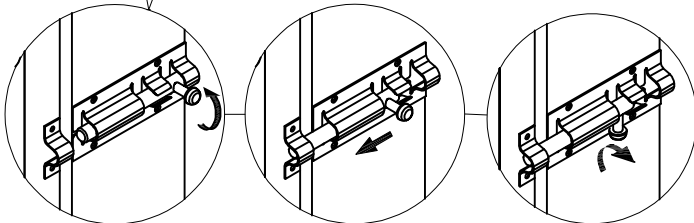
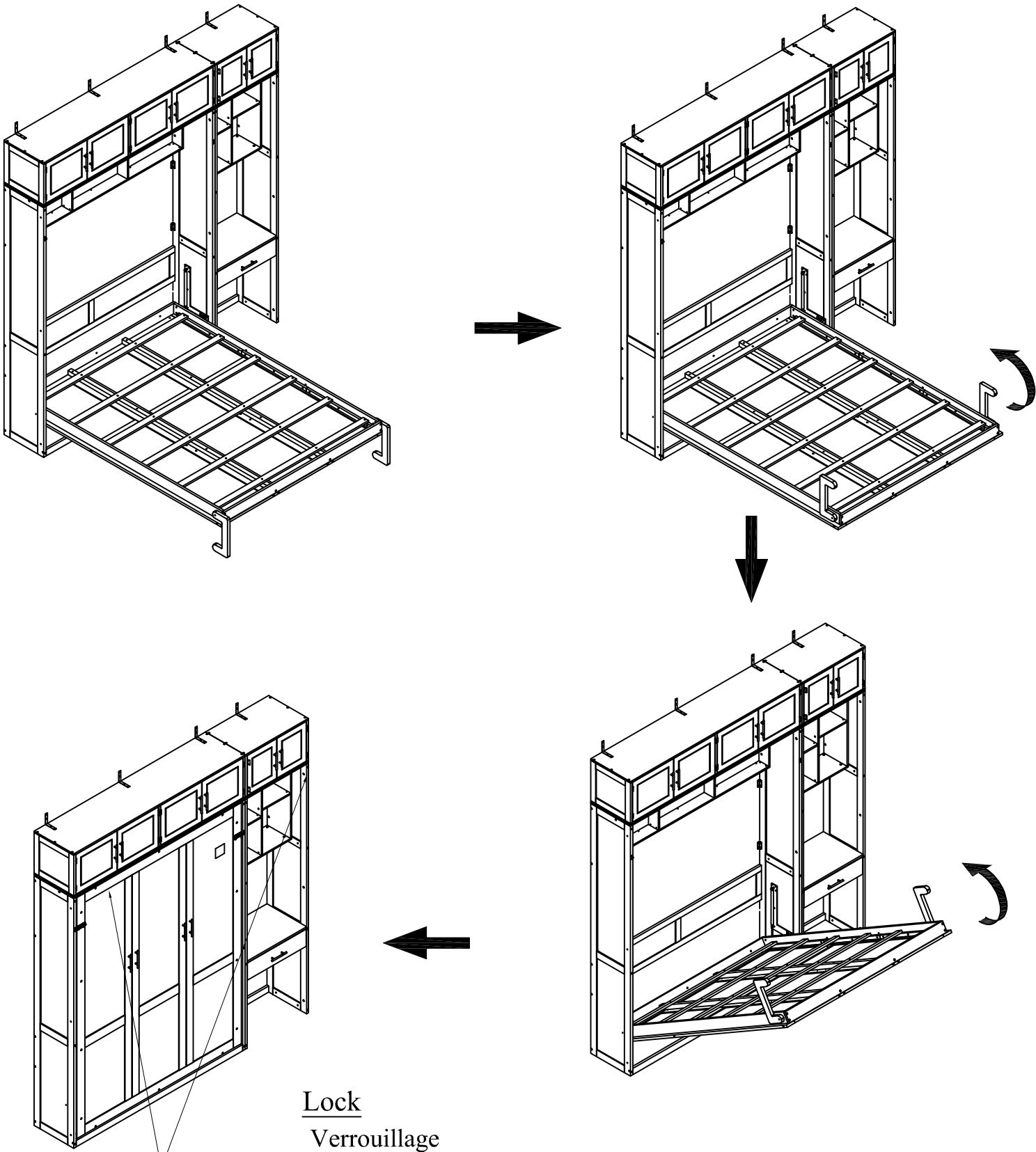

COMPLETED
COMPLÉTÉ

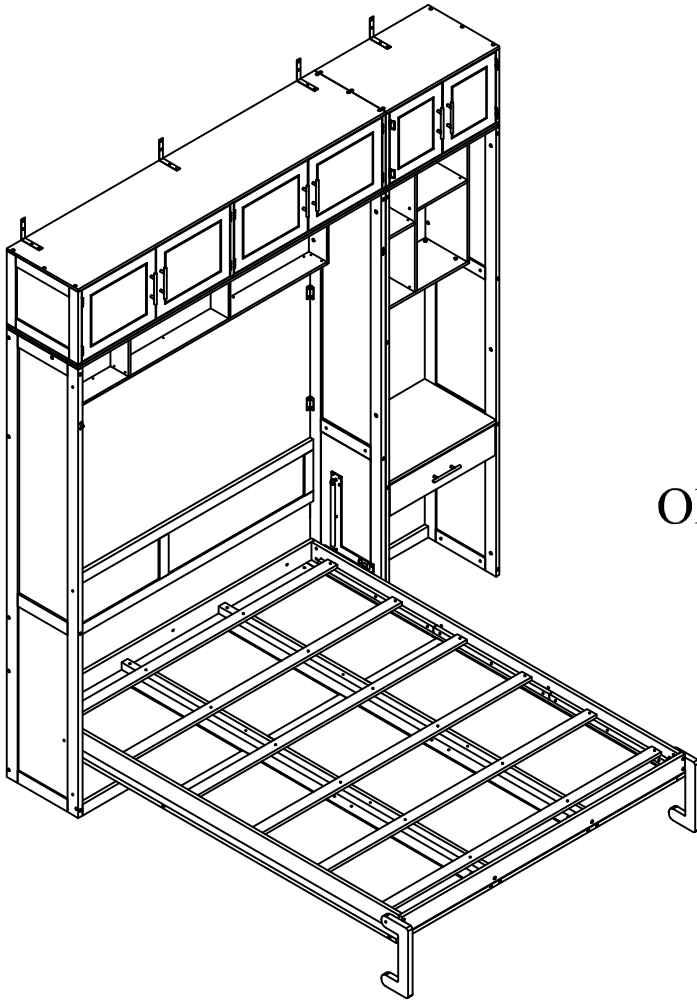

OPTION 1

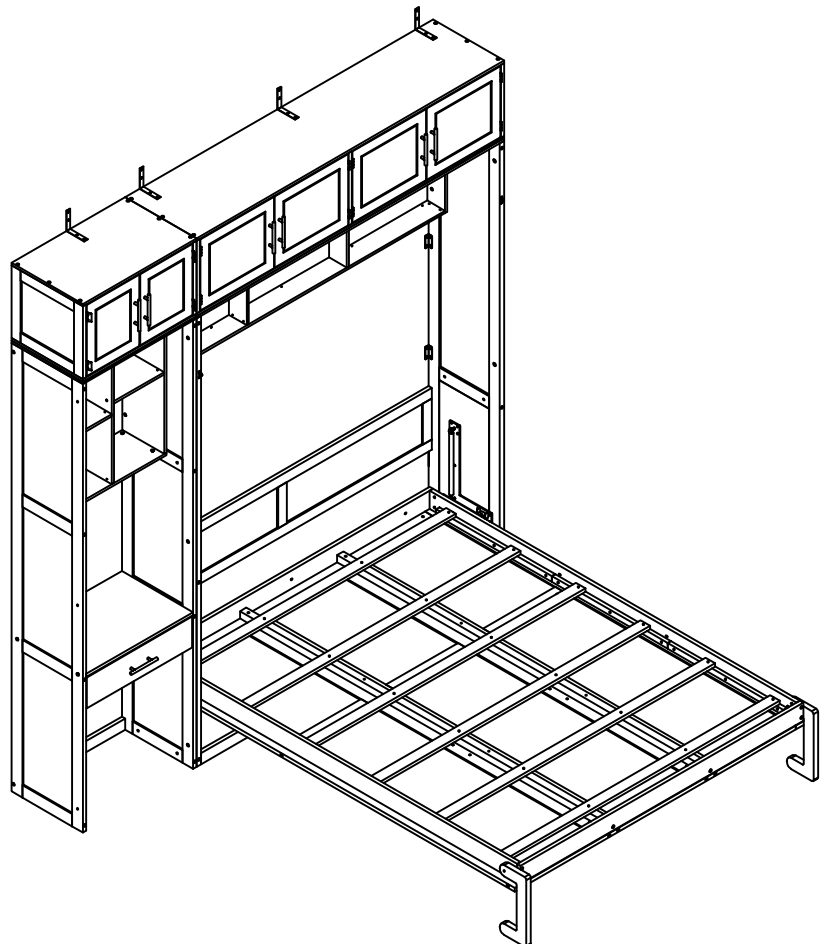

OPTION 2