

Owner Manual

Queen Bed

IMPORTANT

Carefully remove all the parts from the carton and place them individually on a soft cloth to prevent scratches or other damage.

Carefully and strictly follow these assembly instructions to ensure a completed product as designed.

Do not use power tools above 8 volts to assemble.

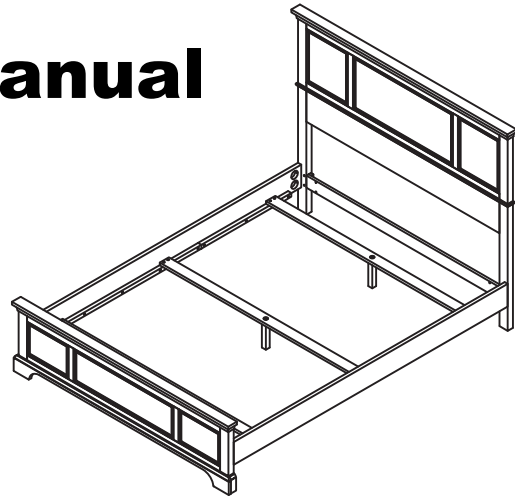

Part List

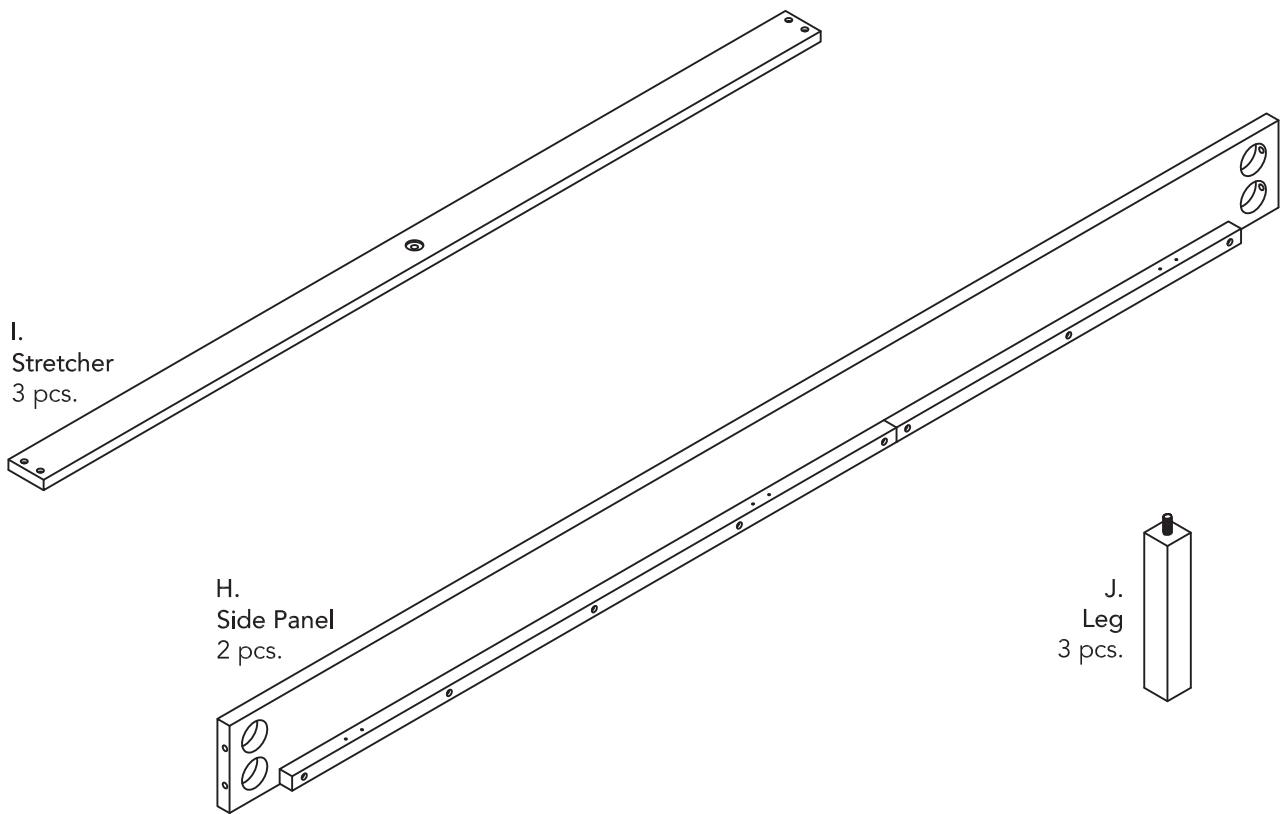

Hardware List



5/16" x 3 1/8"
Bolt
8 pcs. (+1 extra)



Square Washer
8 pcs. (+1 extra)



Nut
8 pcs. (+1 extra)



Wrench
1 pc.

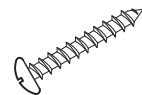

M4x25
Wood Screw
12 pcs. (+1 extra)

Assembly Instructions 2/3

IMPORTANT

- Use a soft cloth between these parts and the floor.
- Do not use power tools above 8 volts to assemble.
- Do not tighten all the screws until each part is properly assembled.
- The unit must be level to work properly. Use the included adjustable levelers to level.
- Keep Wrench as the Nuts may need to be tightened in the future.
- Do not slide bed on floor. To move assembled bed requires two people. Remove any bedding, then lift and carry bed.

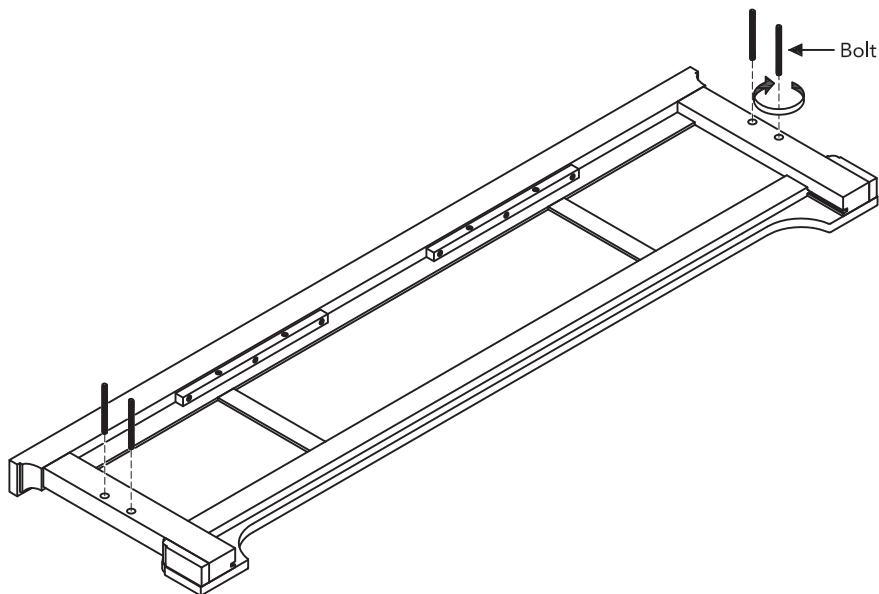
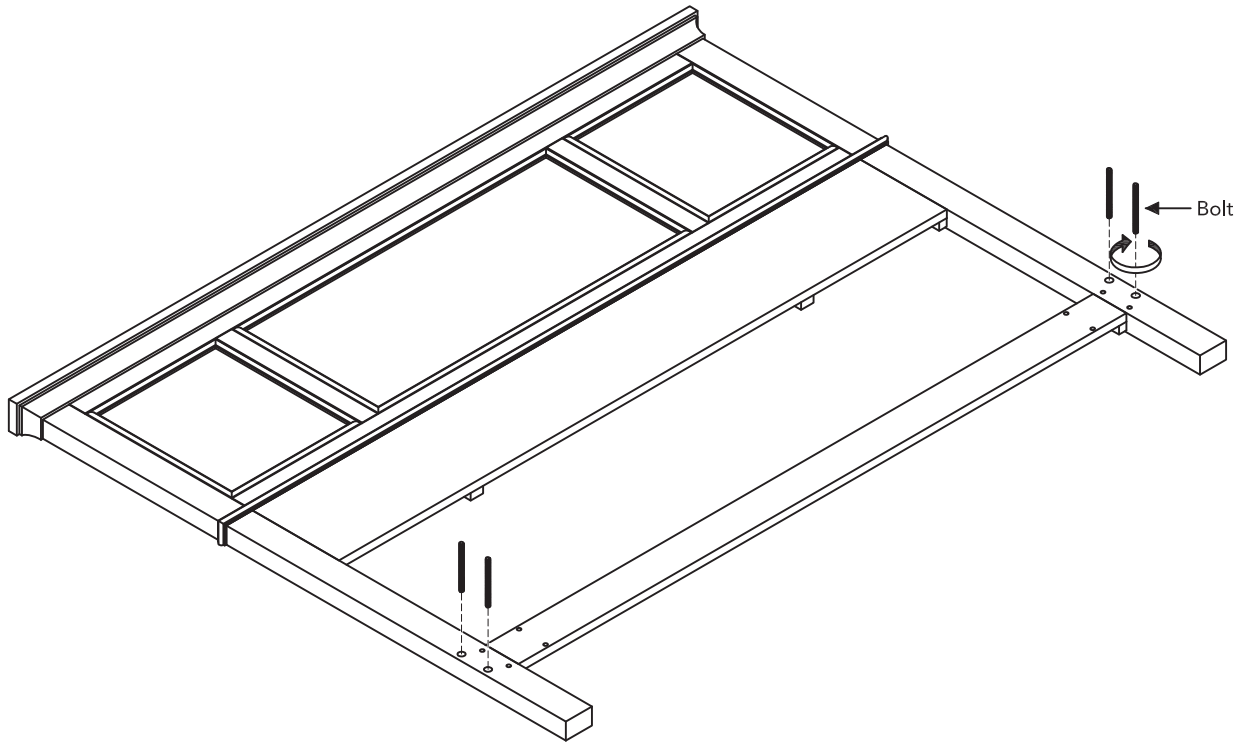

STEP 1

Insert Bolts into pre-drilled holes in Headboard and Footboard, then tighten.

Assembly Instructions 3/3

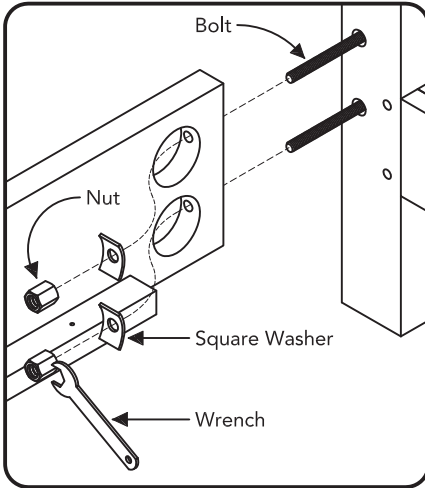
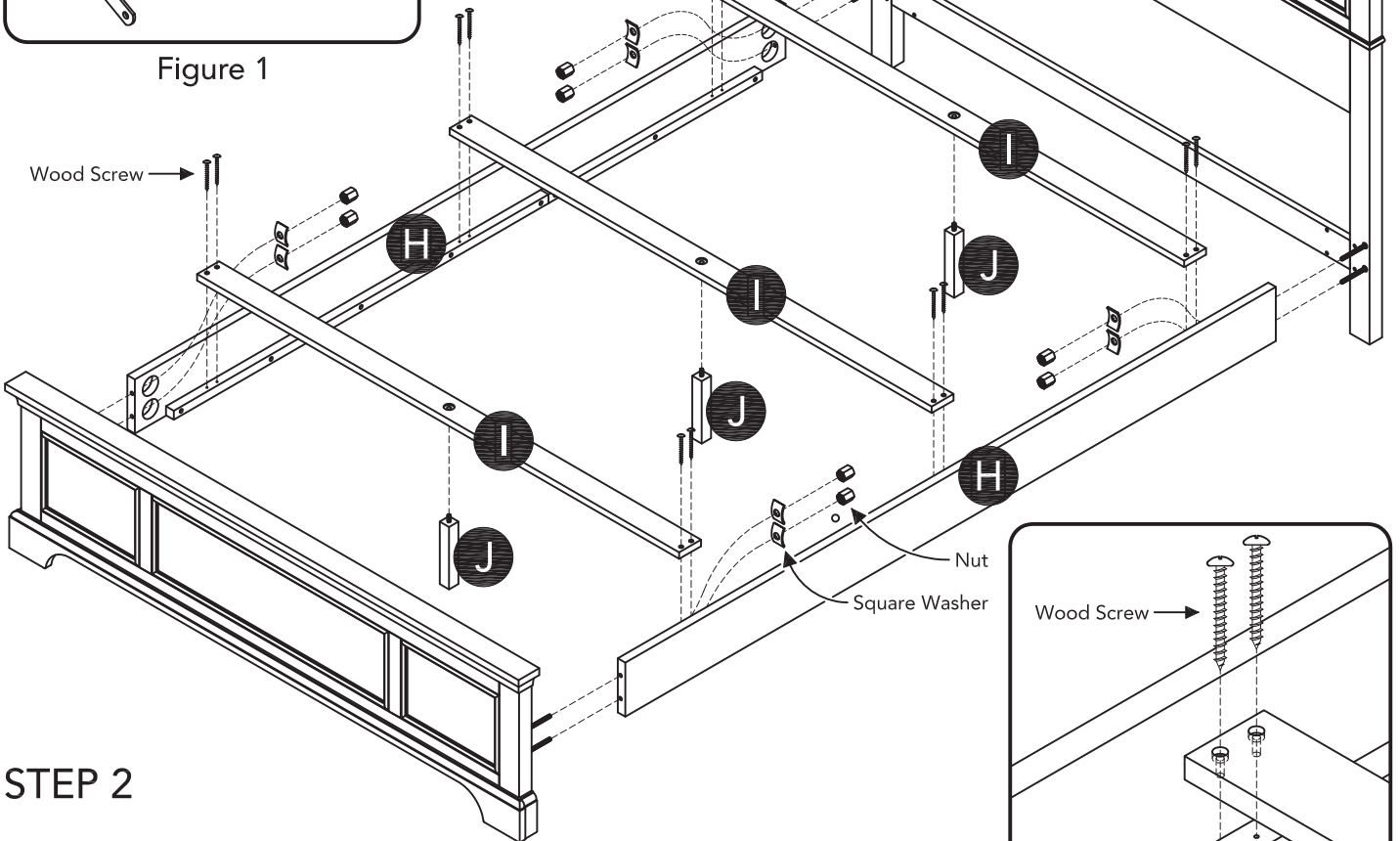

Figure 1

WARNING!

Two people are required for assembly. One person should hold the Headboard and Footboard in the correct position while the other attaches the Side Panel (H) to avoid damage.



STEP 2

Attach Side Panels (H) to Headboard and Footboard with Square Washers and Nuts.

Tighten all Nuts with Wrench. (See Figure 1)

Insert Legs (J) into pre-drilled holes in Stretchers (I) and tighten.

Attach Stretchers (I) to unit with Wood Screws into pre-drilled holes. (See Figure 2)

Level unit by adjusting the adjustable levelers on bottom of legs. (See Figure 3)

Note: Unit must be level to work properly.

Note: Do not slide bed on floor. To move assembled bed requires two people. Remove any bedding, then lift and carry bed.

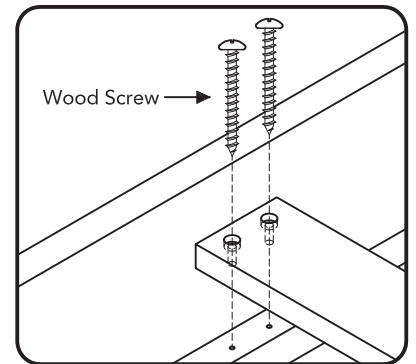

Figure 2

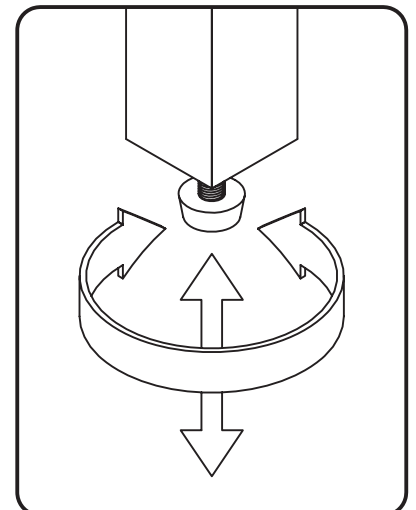

Figure 3

CARE INSTRUCTIONS

NEVER

allow liquids to remain on furniture.
Absorption causes parts to warp
and split and finishes to delaminate.

NEVER

use glass cleaners on
finished furniture. Ammonia
chemically attacks the finish.



Do not use power tools
above 8 volts to assemble.

**PREVENT
CRACKING**



Do not place
in direct sunlight.

**PREVENT
FADING**



Do not write
directly on surface.

**PREVENT
MARKING**



Do not place hot
objects on surface.

**PREVENT
FINISH DAMAGE**



Do not use rubber
based placemats.

**PREVENT
DISCOLORING**



Do not use commercial
waxes and polishes.

**PREVENT
YELLOWING**

CLEAN

with a soft cloth moistened
in lukewarm soap and water.
Buff with a dry clean cloth.



will provide replacements free of charge for missing or damaged parts within 30 days of purchase. Digital images of the defective parts may be required. If the product was not purchased from an authorized retailer, is under no obligation to provide replacement parts. Parts are not available for fully assembled items nor are parts available for sale. Replacements for missing or damaged parts may be requested via contact info below.

Queen Footboard

IMPORTANT

Carefully remove all the parts from the carton and place them individually on a soft cloth to prevent scratches or other damage.

Carefully and strictly follow these assembly instructions to ensure a completed product as designed.

Do not use power tools above 8 volts to assemble.

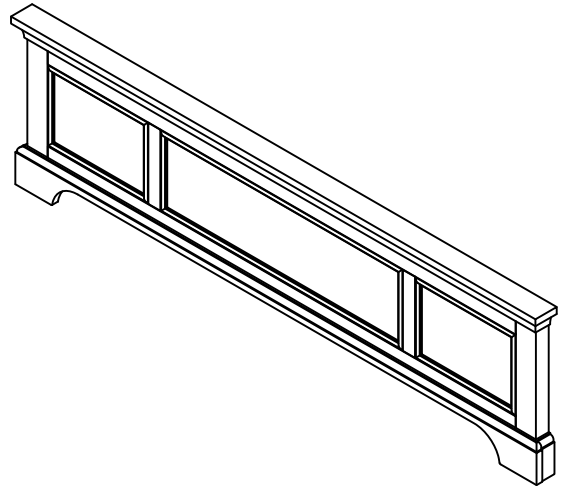

Part List

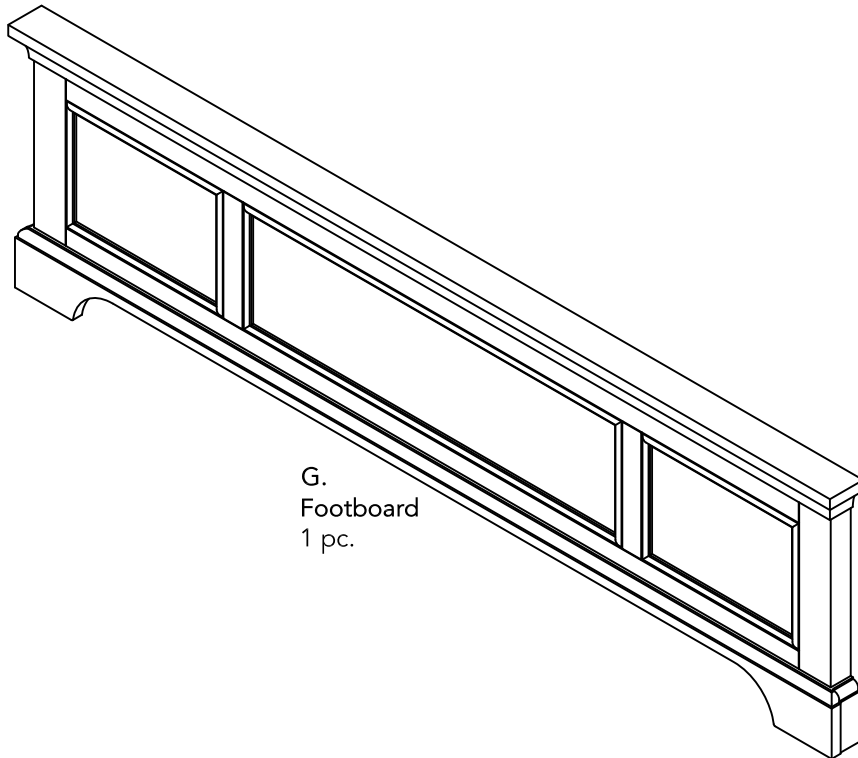

G.
Footboard
1 pc.

Queen Headboard

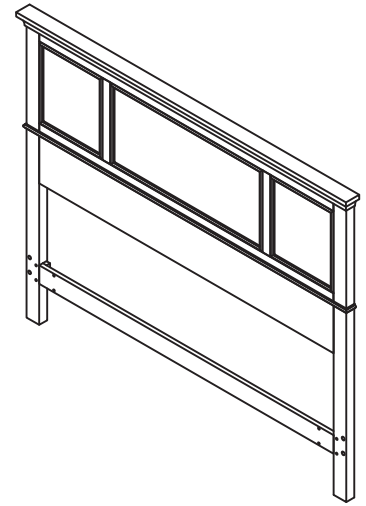

IMPORTANT

Carefully remove all the parts from the carton and place them individually on a soft cloth to prevent scratches or other damage.

Carefully and strictly follow these assembly instructions to ensure a completed product as designed.

Do not use power tools above 8 volts to assemble.

Part List

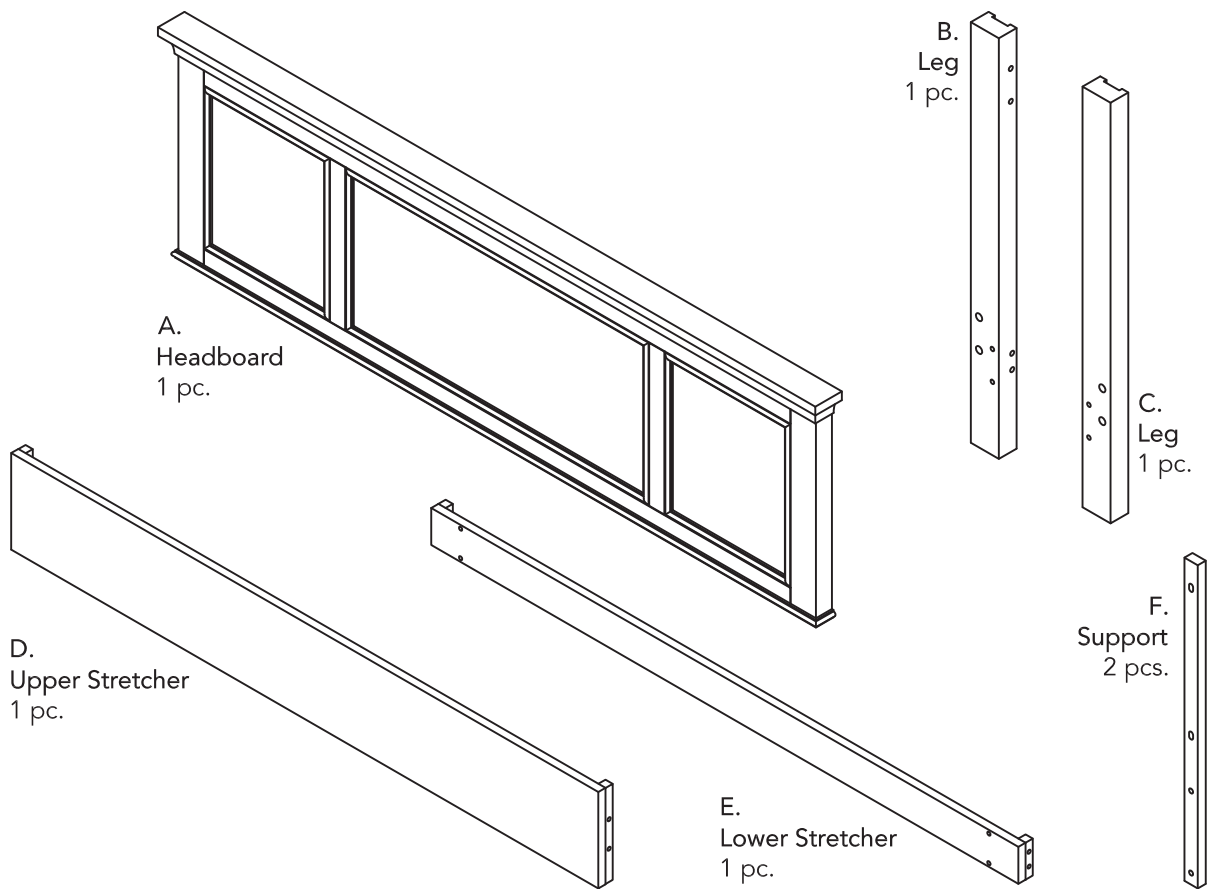

Hardware List



**M6x45
Bolt (long)**
8 pcs. (+1 extra)



**M6x30
Bolt (middle)**
8 pcs. (+1 extra)



**M6x20
Bolt (short)**
8 pcs. (+1 extra)



Flat Washer
8 pcs. (+1 extra)

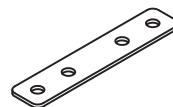

Bracket
2 pcs.



Hex Wrench
1 pc.



Hex Wrench (small)
1 pc.

Assembly Instructions 2/3

IMPORTANT

- Use a soft cloth between these parts and the floor.
- Do not use power tools above 8 volts to assemble.
- Do not tighten up all the bolts until each part is properly assembled.
- Keep Hex Wrench as the bolts may need to be tightened in the future.

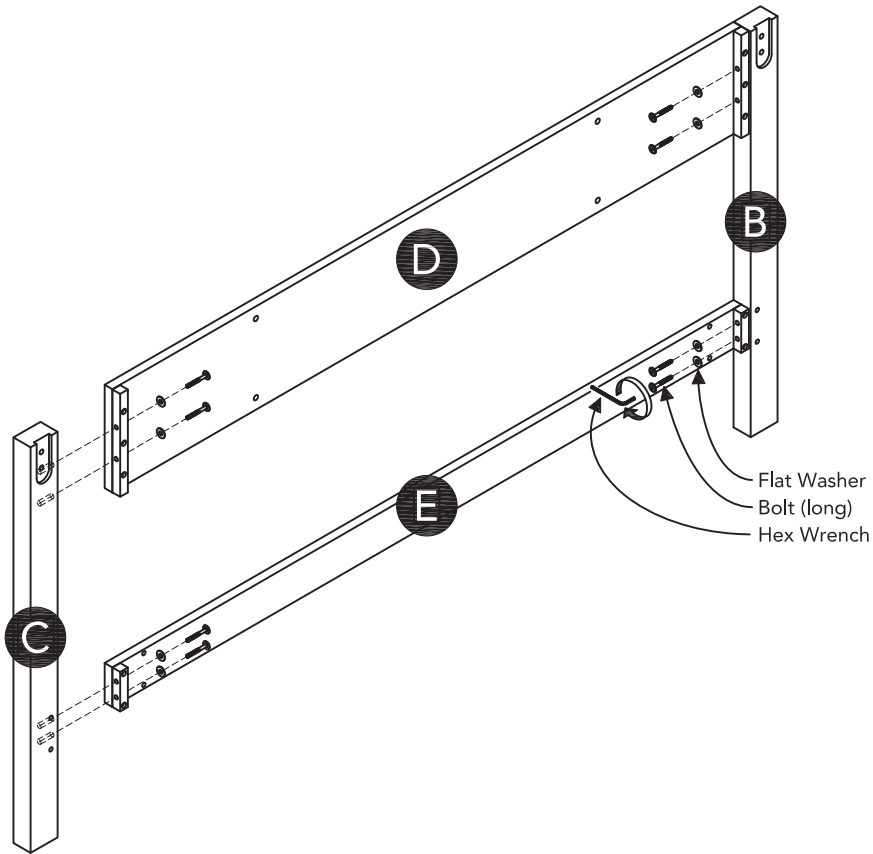

STEP 1

Attach Legs (B) and (C) to Upper Stretcher (D) and Lower Stretcher (E) with Bolts (long) and Flat Washers.

Tighten bolts with Hex Wrench.
(See Figure 1)

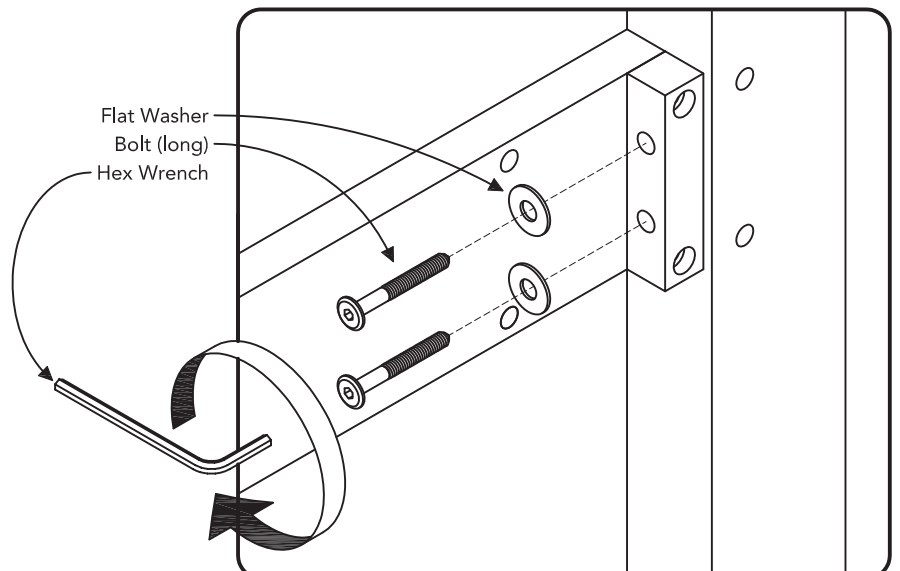

Figure 1

Assembly Instructions 3/3

STEP 2

Attach Headboard (A) to unit by attaching Supports (F) to Headboard (A) and unit with Bolts (middle).

Attach Brackets to Headboard (A) and unit with Bolts (short).

Tighten bolts with Hex Wrench.

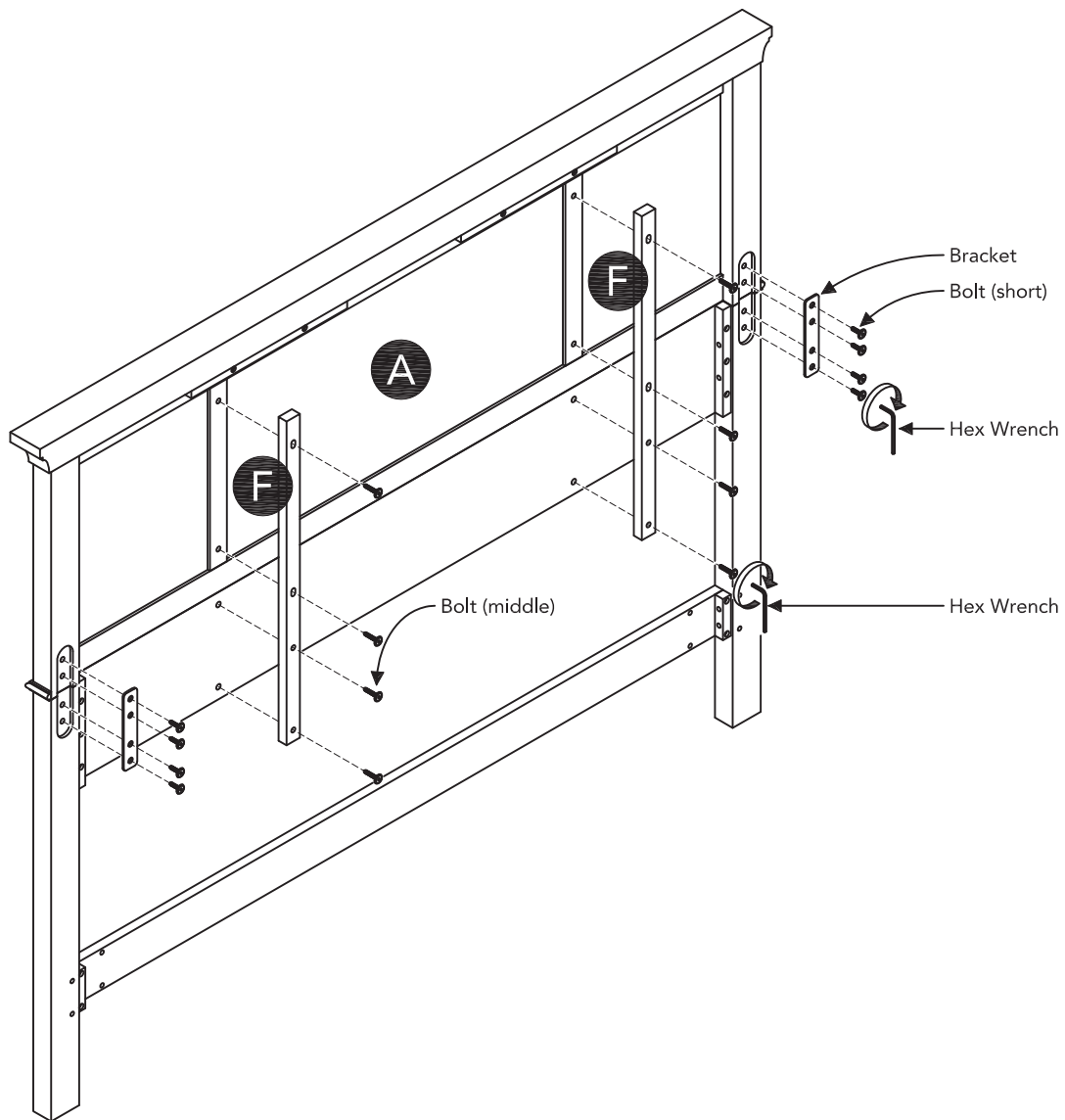

How to Attach Headboard to Metal Bed Frame

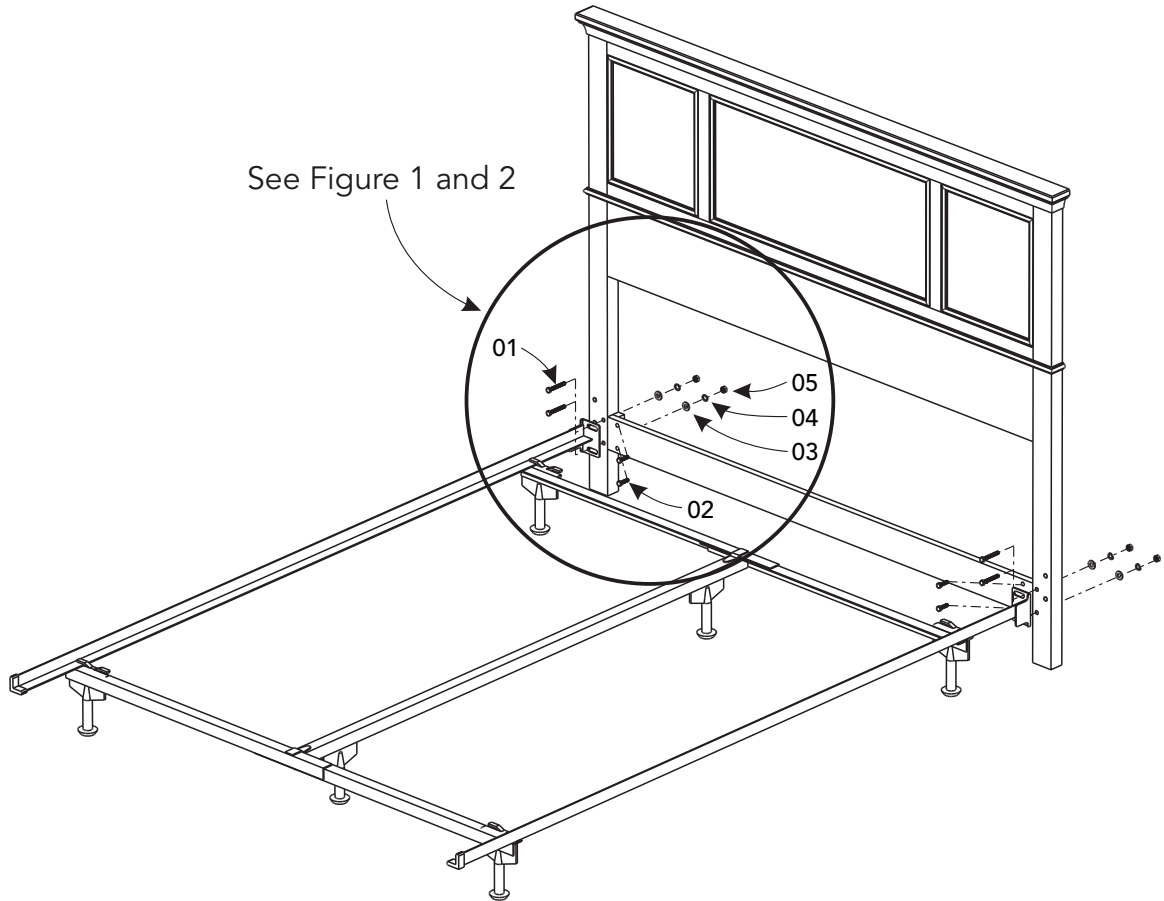

See Figure 1 and 2

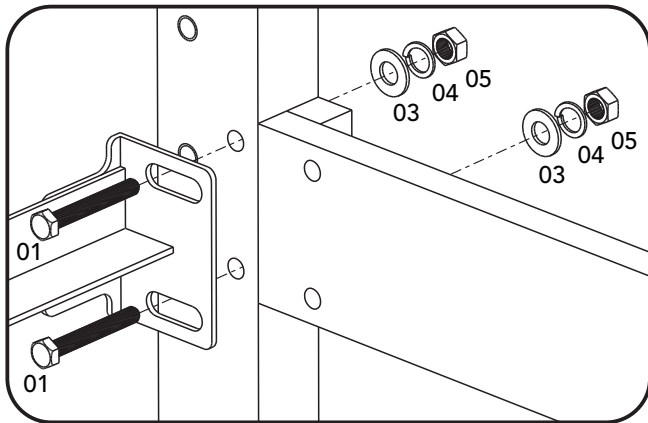

Holes for Queen Metal Bed Frame.
(See Figure 1)

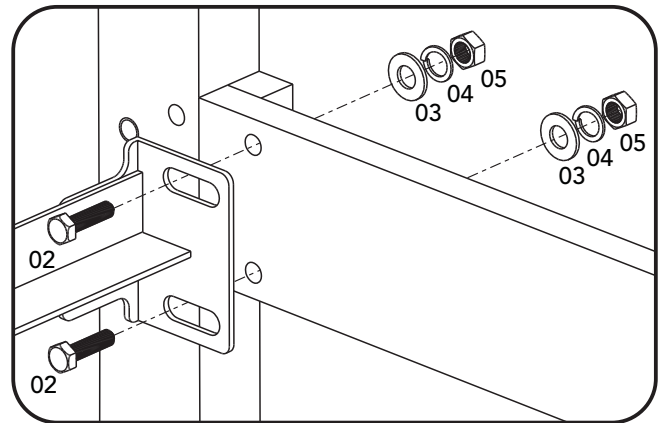

Holes for Full Metal Bed Frame.
(See Figure 2)

Hardware List (Not Included)

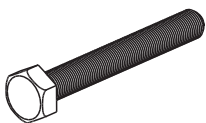

01
Machine Screw M8 x 55
4 pcs.

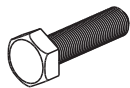

02
Machine Screw M8 x 35
4 pcs.



03
Flat Washer M8
4 pcs.



04
Spring Washer M8
4 pcs.



05
Nut M8
4 pcs.

CARE INSTRUCTIONS

NEVER

allow liquids to remain on furniture.
Absorption causes parts to warp
and split and finishes to delaminate.

NEVER

use glass cleaners on
finished furniture. Ammonia
chemically attacks the finish.



Do not use power tools
above 8 volts to assemble.

**PREVENT
CRACKING**



Do not place
in direct sunlight.

**PREVENT
FADING**



Do not write
directly on surface.

**PREVENT
MARKING**



Do not place hot
objects on surface.

**PREVENT
FINISH DAMAGE**



Do not use rubber
based placemats.

**PREVENT
DISCOLORING**



Do not use commercial
waxes and polishes.

**PREVENT
YELLOWING**

CLEAN

with a soft cloth moistened
in lukewarm soap and water.
Buff with a dry clean cloth.



will provide replacements free of charge for missing or damaged parts within 30 days of purchase. Digital images of the defective parts may be required. If the product was not purchased from an authorized retailer, is under no obligation to provide replacement parts. Parts are not available for fully assembled items nor are parts available for sale. Replacements for missing or damaged parts may be requested via contact info below.

Bedford Drawer Chest (Ebony Finish)

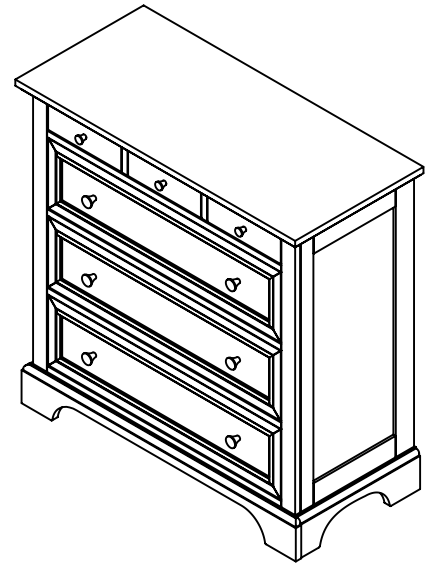

IMPORTANT NOTE

Carefully remove all the parts from the carton and put them individually on a soft cloth to prevent scratches or other damages occurring to the wood parts.

We have taken great care in the design of this product and request that you carefully and strictly follow our assembly instructions to ensure a completed product as it was designed.

Part List

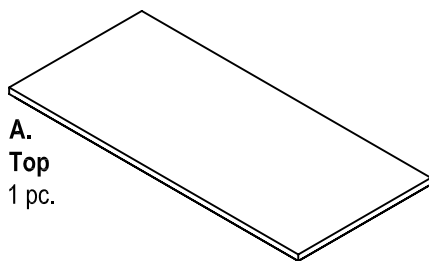

A.
Top
1 pc.

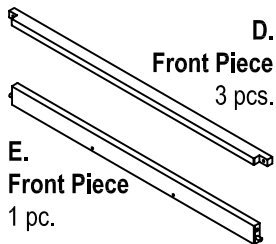

D.
Front Piece
3 pcs.

E.
Front Piece
1 pc.

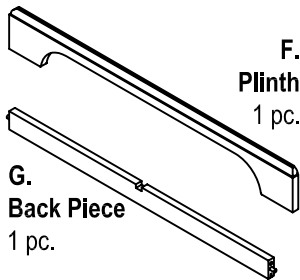

F.
Plinth
1 pc.

G.
Back Piece
1 pc.

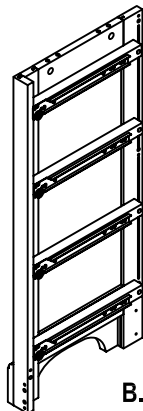

B.
Side Panel
1 pc.

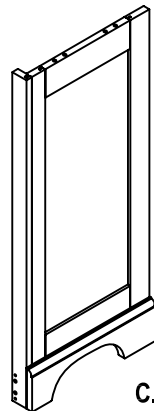

C.
Side Panel
1 pc.

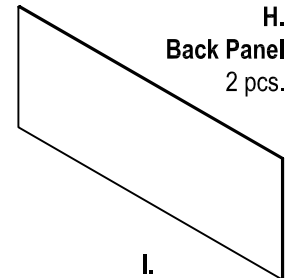

H.
Back Panel
2 pcs.

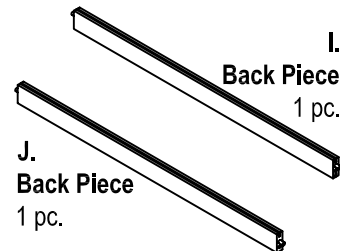

I.
Back Piece
1 pc.

J.
Back Piece
1 pc.

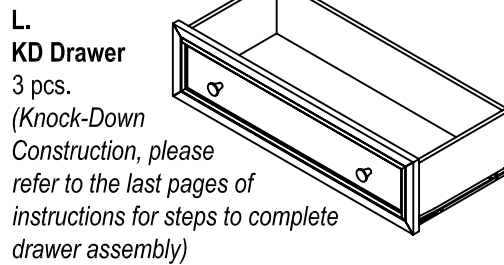

L.
KD Drawer
3 pcs.
(Knock-Down Construction, please refer to the last pages of instructions for steps to complete drawer assembly)

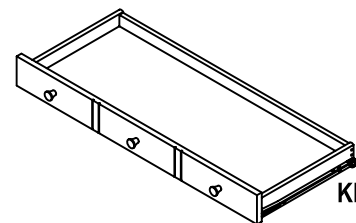

K.
KD Drawer
1 pc.
(Knock-Down Construction, please refer to the last pages of instructions for steps to complete drawer assembly)

Hardware List

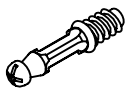

Cam Lock Screw
12 pcs. (+1 extra)



Cam Lock
12 pcs. (+1 extra)

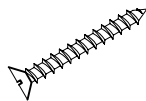

1 1/4" Flat Head Screw
44 pcs. (+1 extra)



3/4" Flat Head Screw
24 pcs. (+1 extra)

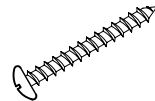

1 1/4" Round Head Screw
7 pcs. (+1 extra)

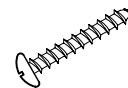

1" Round Head Screw
6 pcs. (+1 extra)



5/8" Round Head Screw
13 pcs. (+1 extra)



Machine Screw
9 pcs.

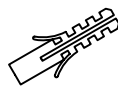

Anchor
1 pc. (+1 extra)



Flat Washer
2 pcs. (+1 extra)



Large Pull Handle
6 pcs.



Small Pull Handle
3 pcs.



Wooden Dowel
8 pcs. (+1 extra)



Tipping Restraint
1 pc.

Assembly Instructions 2/8

IMPORTANT

Do not tighten up all the screws until each part is properly assembled.

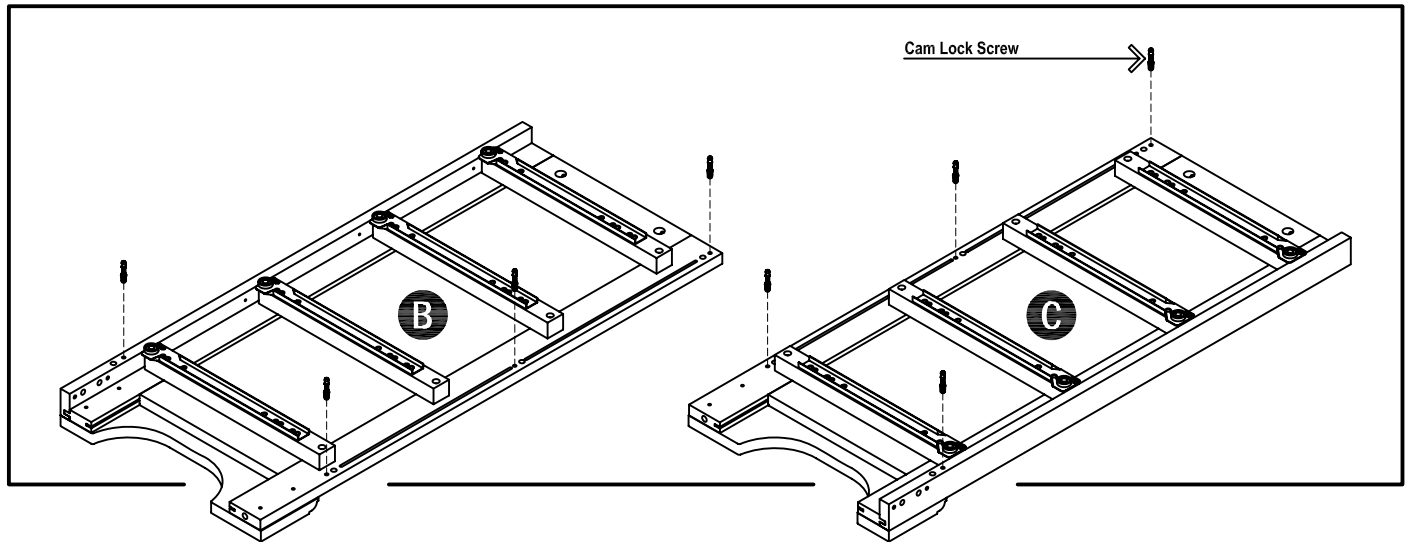

STEP 1

Insert Cam Lock Screws into the pre-drilled holes of Side Panel (B) and (C).

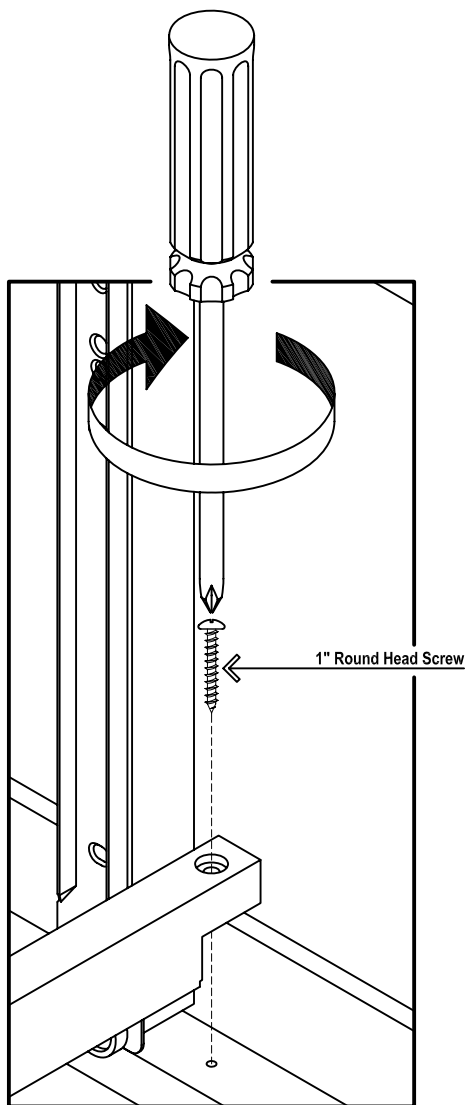
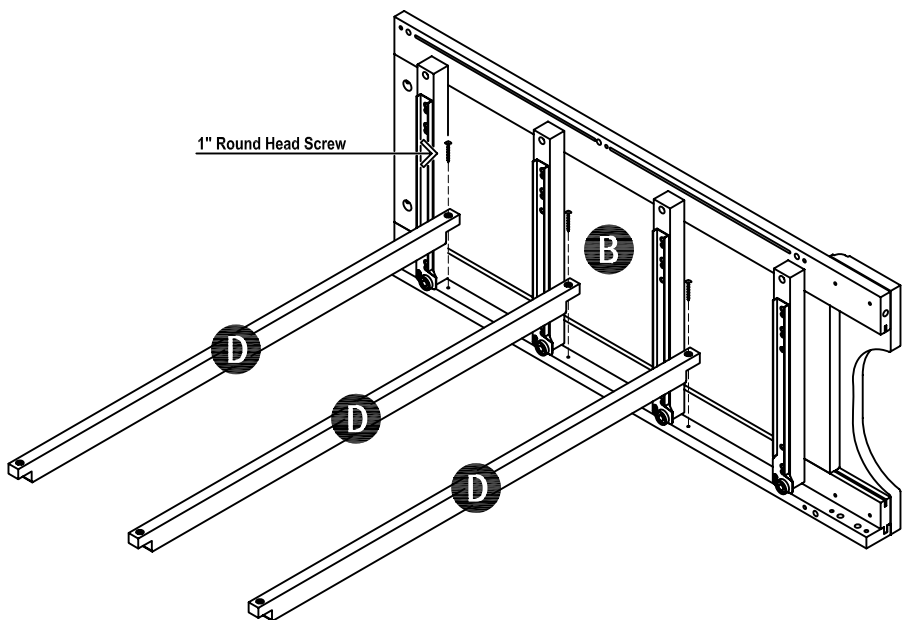

Figure 1



STEP 2

Attach Front Piece (D) to Side Panel (B) with 1" Round Head Screws. (See figure 1)

Assembly Instructions 3/8

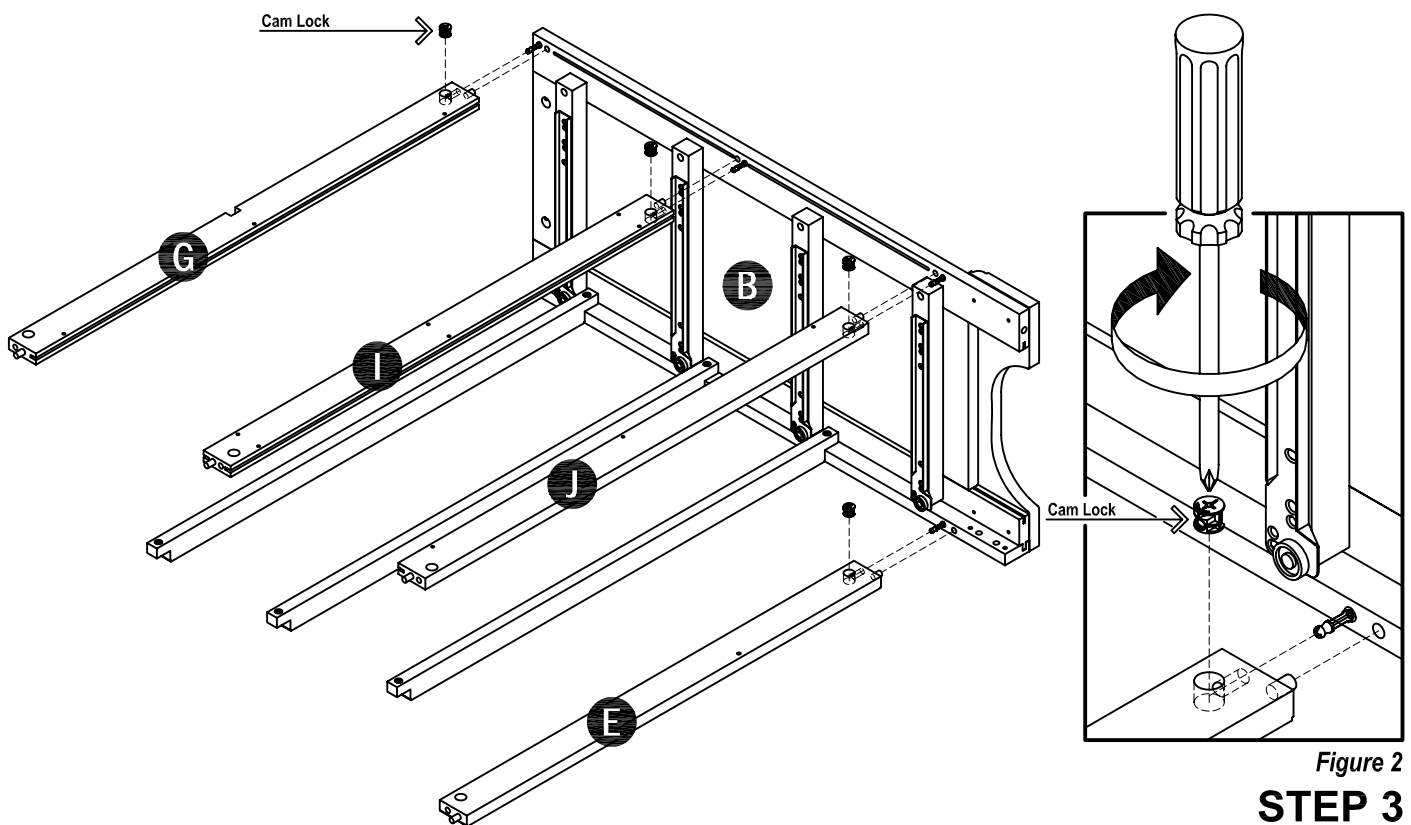

Attach Front Piece (E) and Back Piece (G, I, J) to Side Panel (B) with Cam Locks.
(See figure 2)

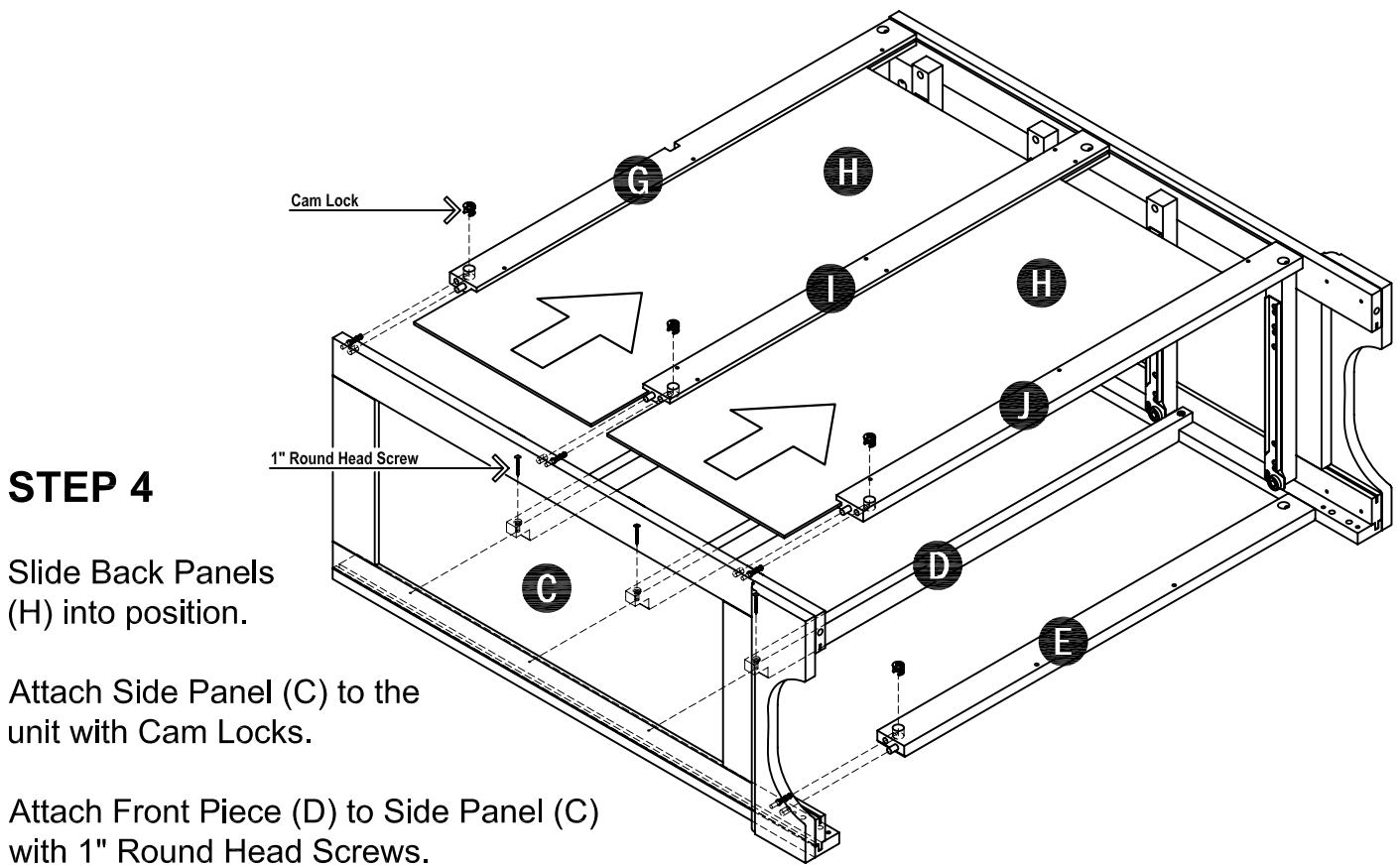

Assembly Instructions 4/8

STEP 5

Insert Cam Lock Screws into the pre-drilled holes of Top (A).

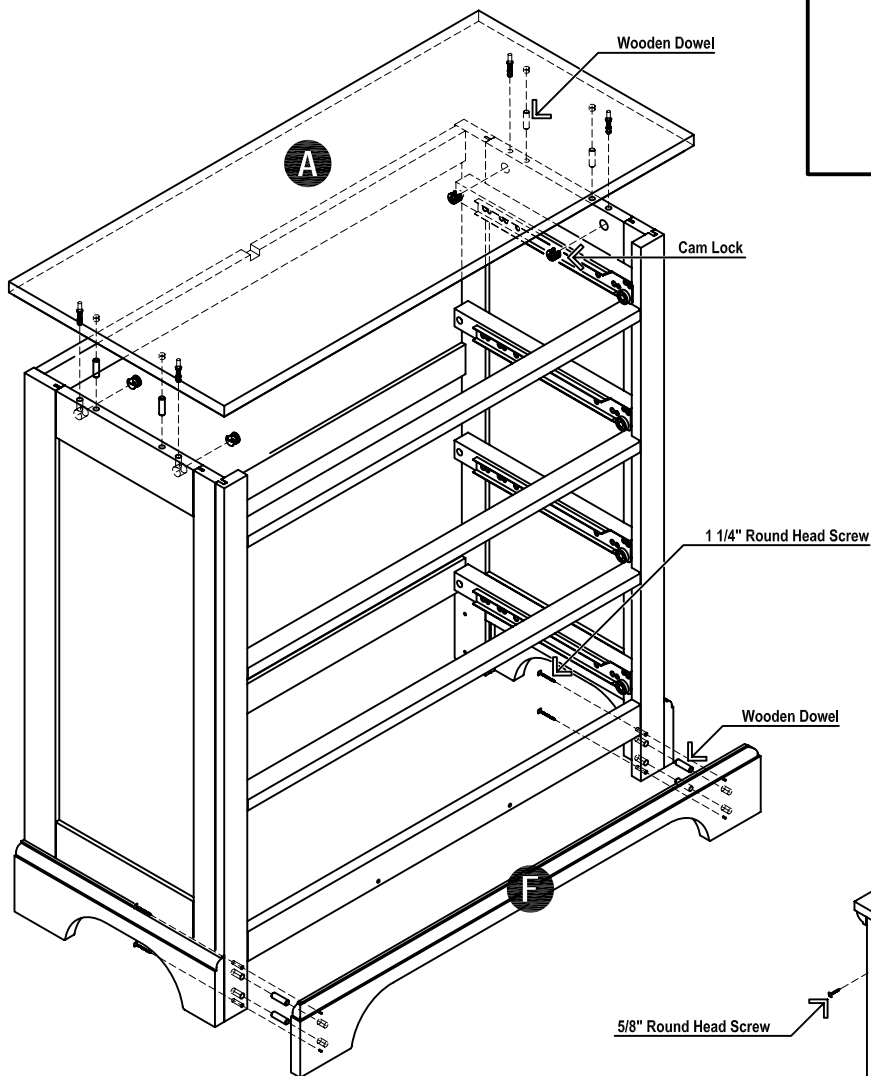
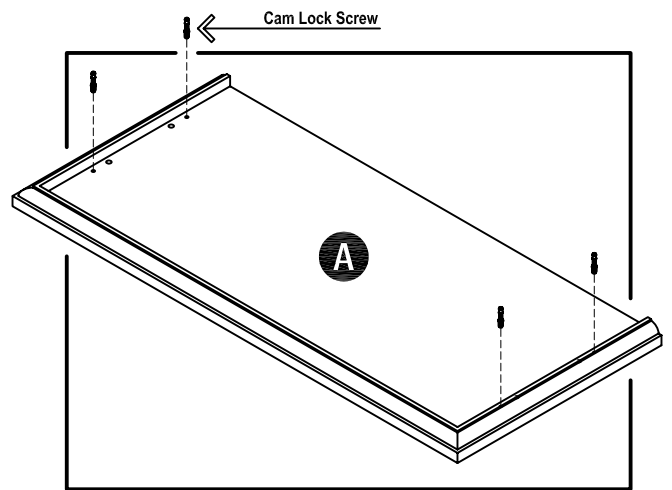

STEP 6

Place Top (A) onto the unit using Cam Locks & Wooden Dowels.

Attach Plinth (F) to the unit using 1 1/4" Round Head Screws & Wooden Dowels.

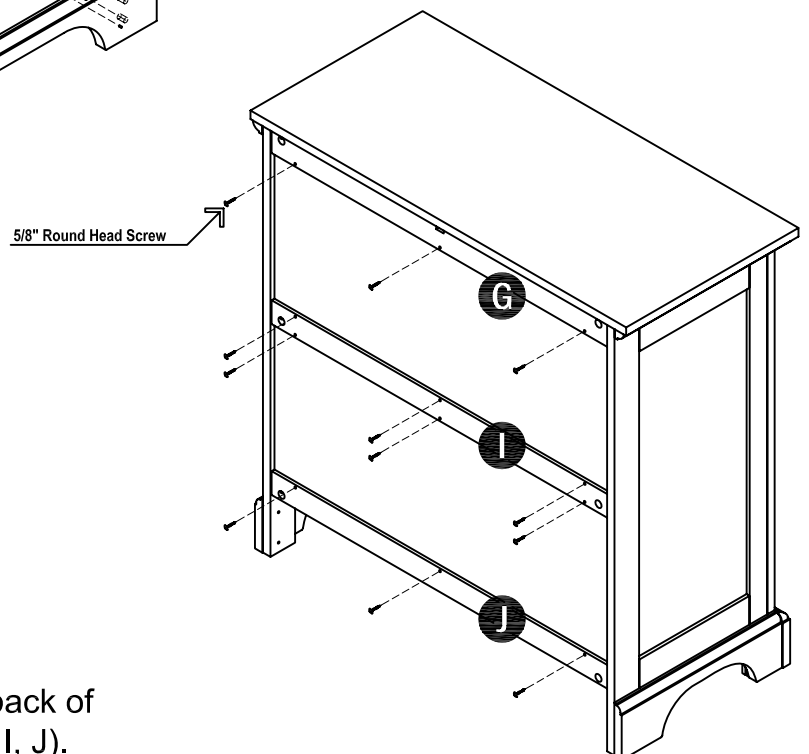

STEP 7

Attach 5/8" Round Head Screws to the back of unit through the holes of Back Piece (G, I, J).

Assembly Instructions 5/8

ATTENTION! For safety reasons, please follow these instruction to prevent the unit from tipping over.

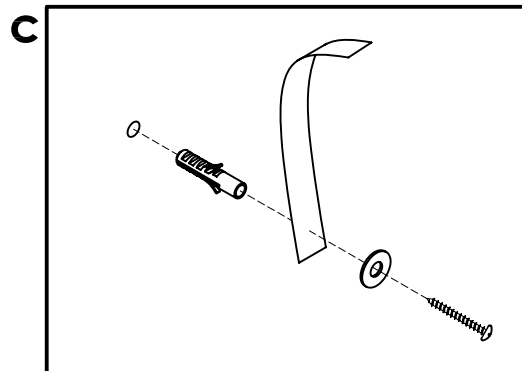
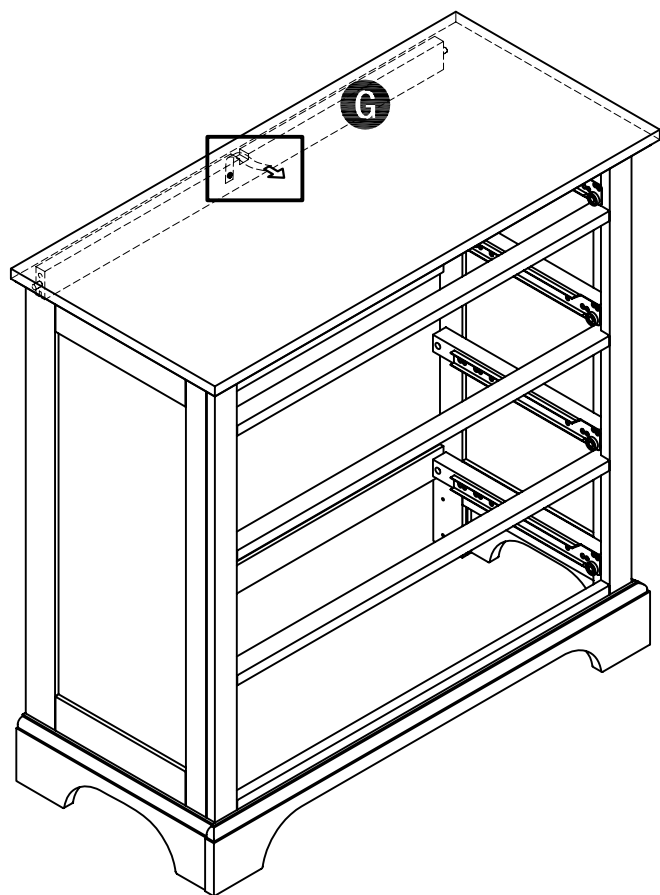

Attach Tipping Restraint to the wall using 1 1/4" Round Head Screw, Flat Washer & Anchor.

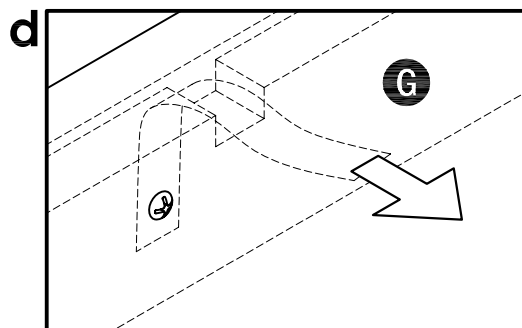

Insert Tipping Restraint to unit through the groove of Back Piece (G).

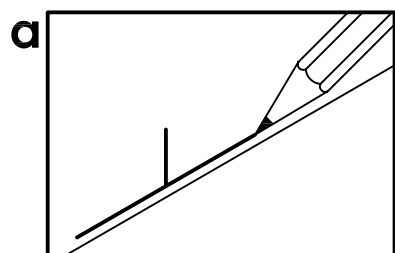

Place the unit on the wall at desired location. Mark with pencil to show the height and center of unit.

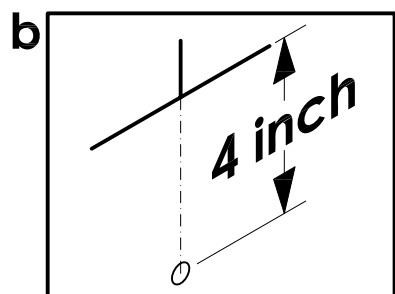

Move unit and drill the wall $\text{Ø}7/32$ inch and $1\ 3/16$ inch deep with position 4 inch down directly under the mark.

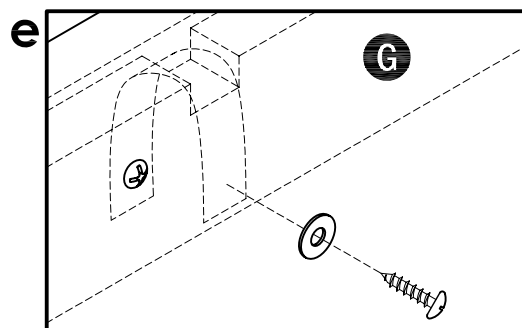

Screw Tipping Restraint to unit using 5/8" Round Head Screw & Flat Washer.

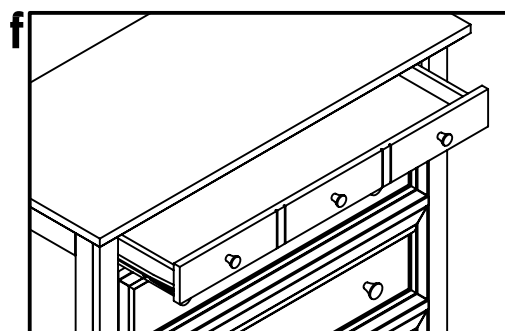

Insert drawers (K, L) into unit.

Drawer (K)

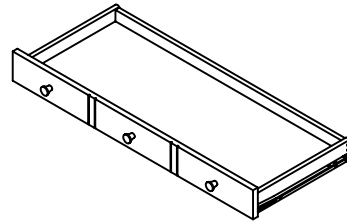

STEP 1

Attach Base Part (K6) to Front Part (K1) and Back Part (K2).

Attach Side Part (K3) to Front Part (K1) and Back Part (K2) using a Phillips screwdriver and 1 1/4" Flat Head Screws.

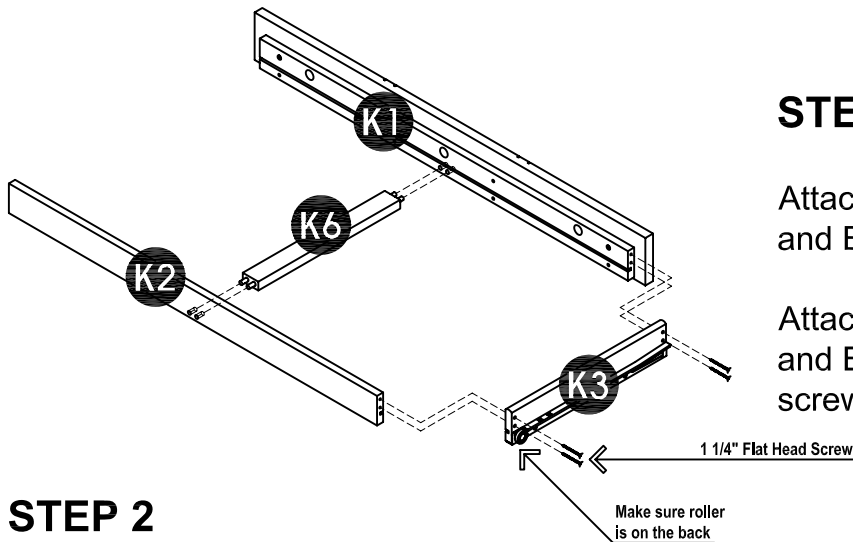

STEP 2

Insert Base Part (K5) into the groove.

Attach Side Part (K4) to Front Part (K1) and Back Part (K2) using a Phillips screwdriver and 1 1/4" Flat Head Screws.

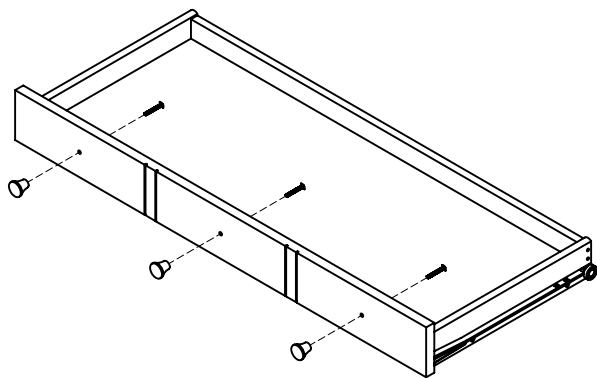
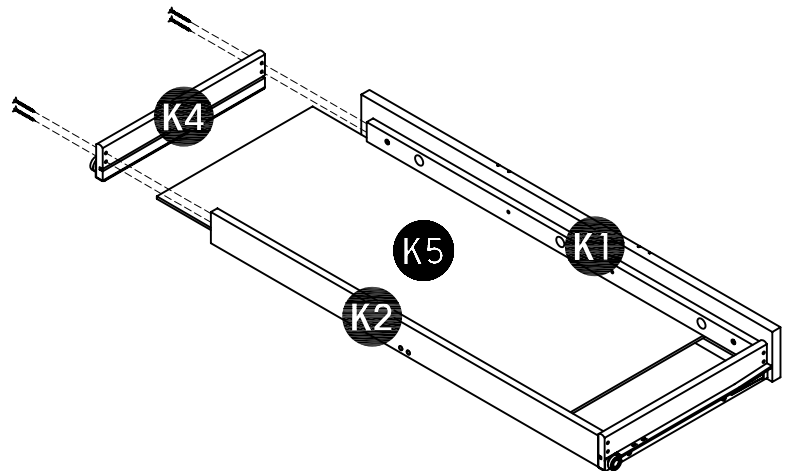

STEP 3

Attach Small Pull Handles with machine screws.

Part List

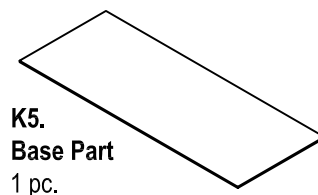
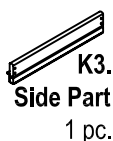
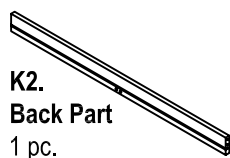
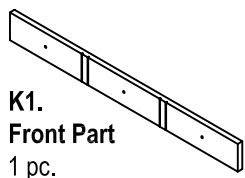

Drawer (L)

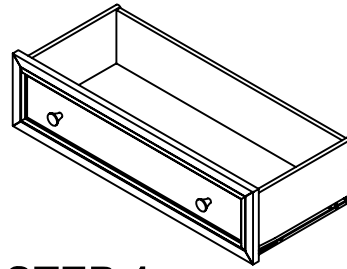

STEP 1

Attach Base Part (K6) to Front Part (L1) and Back Part (L2).

Attach Side Part (L3) to Front Part (L1) and Back Part (L2) using a Phillips screwdriver and 1 1/4" Flat Head Screws.

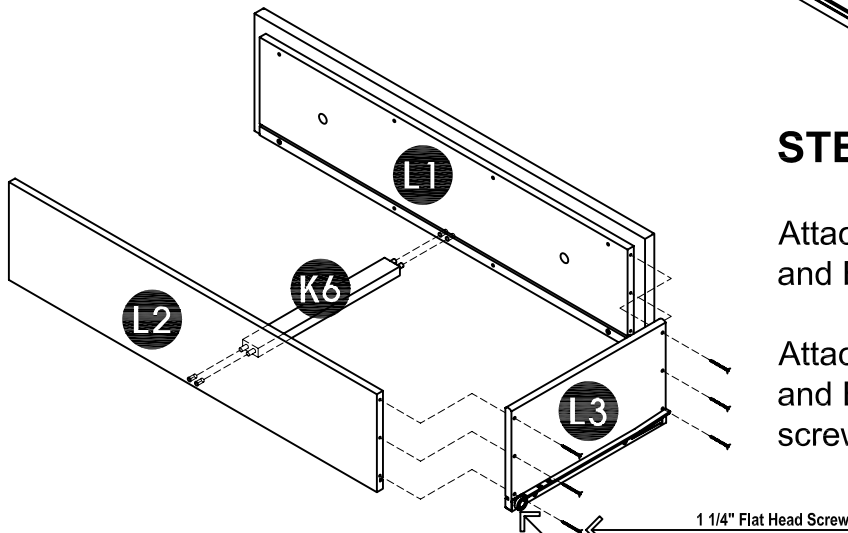

STEP 2

Insert Base Part (K5) into the groove.

Attach Side Part (L4) to Front Part (K2) and Back Part (K4) using a Phillips screwdriver and 1 1/4" Flat Head Screws.

Make sure roller is on the back

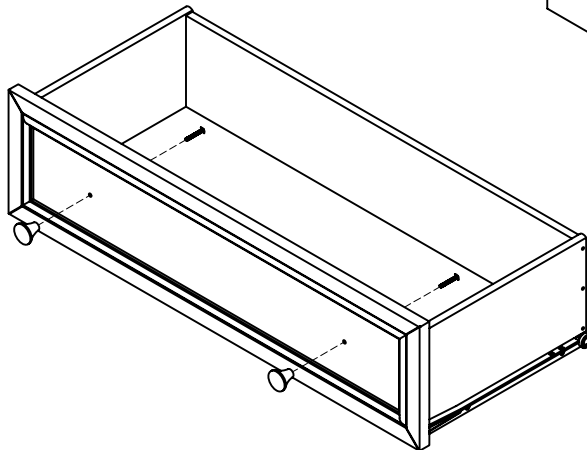
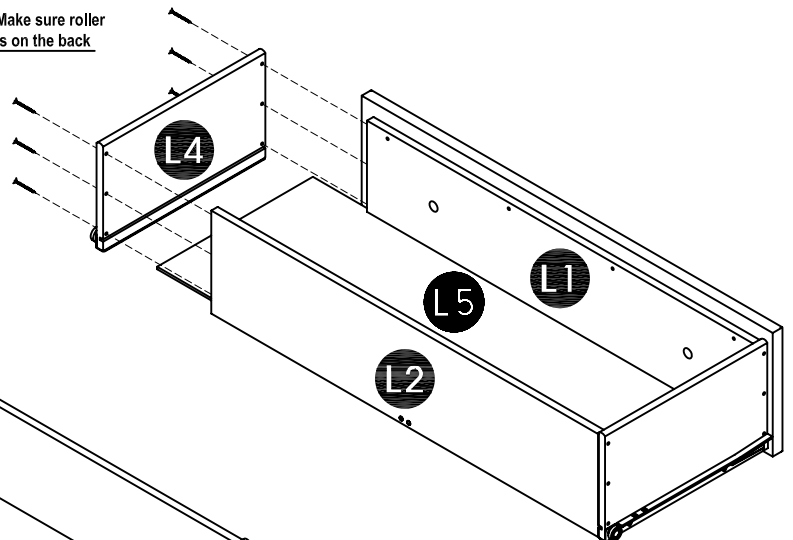

STEP 3

Attach Large Pull Handles with machine screws.

Part List

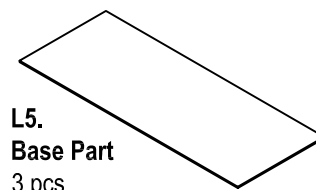
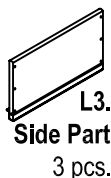
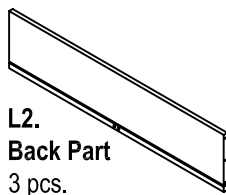
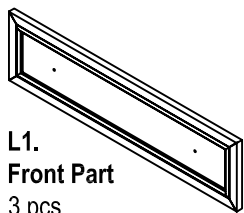

Assembly Instructions 8/8

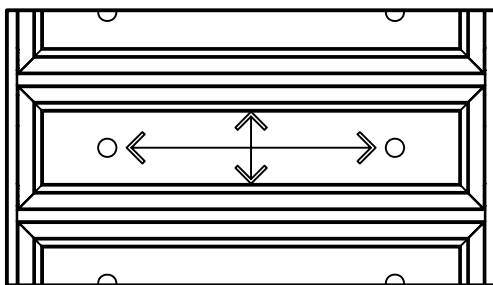
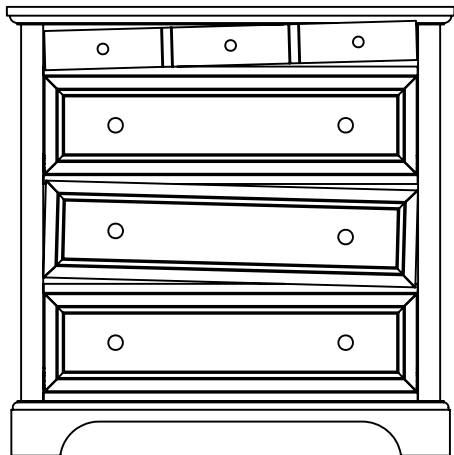

I. IF THE DRAWER DOES NOT ALIGN

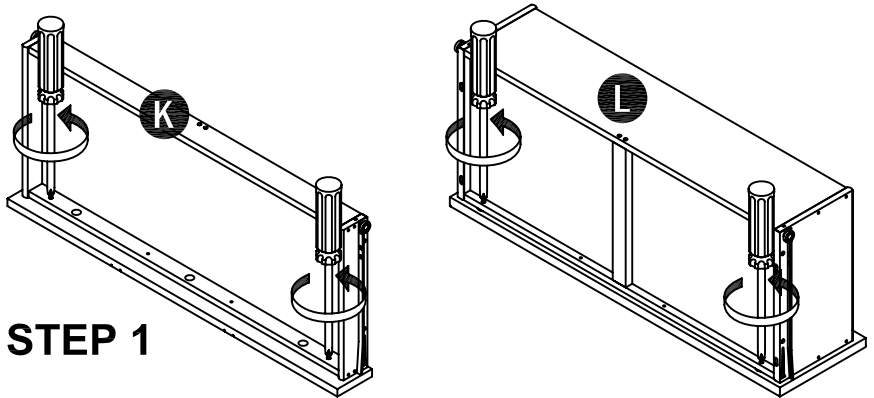

STEP 1

Loosen slightly the upper screws for Drawer (K) & the lower screws for Drawer (L).

STEP 2

Insert the drawer into the main body, then adjust the drawer front panel left or right and up or down, until the drawer gaps look proportional.

II. IF THE DRAWER ALREADY ALIGNS

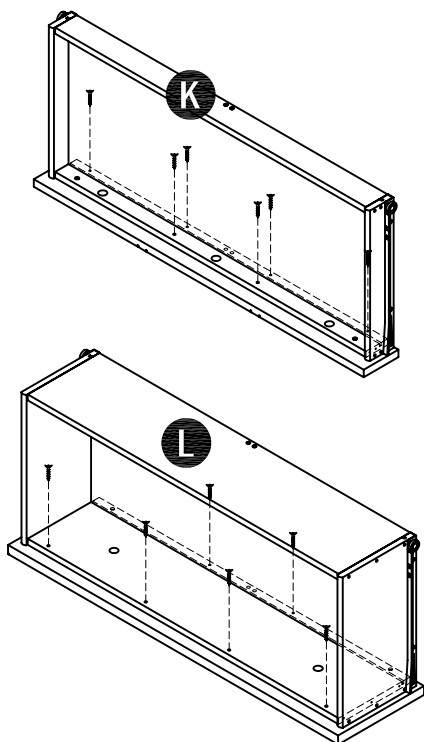

Pull out drawer slowly. Lock the drawer front panel into position with 3/4" Flat Head Screws.

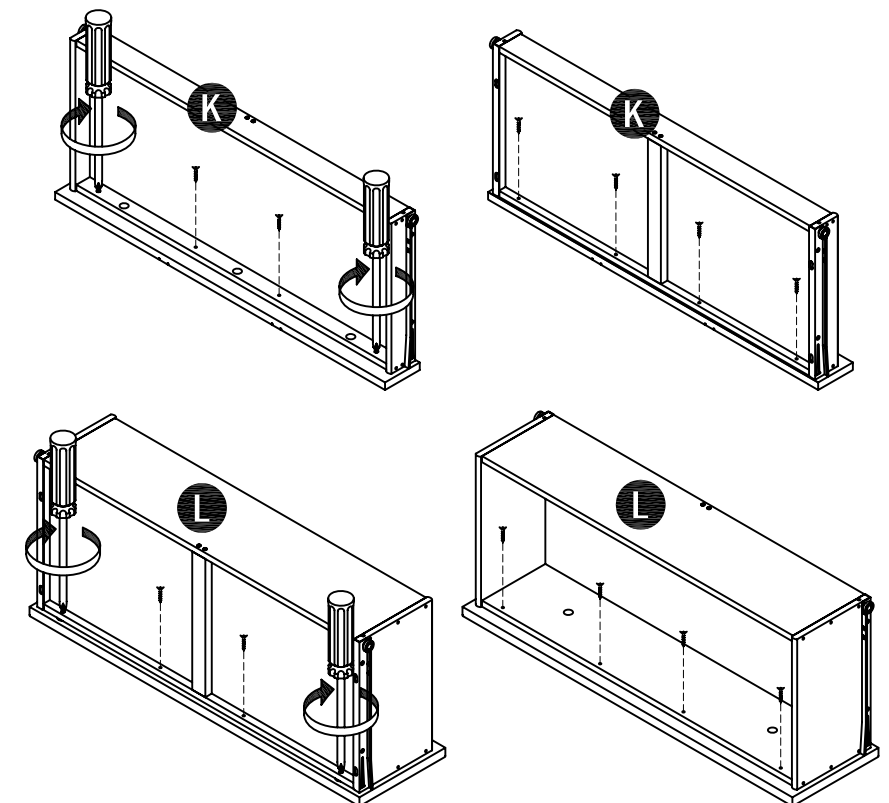

STEP 3

Pull the drawer open slowly and tighten the upper screws. Make sure the front panel does not move and lock the drawer front panel into position with 3/4" Flat Head Screws.

Bedford Night Stand (Ebony Finish)

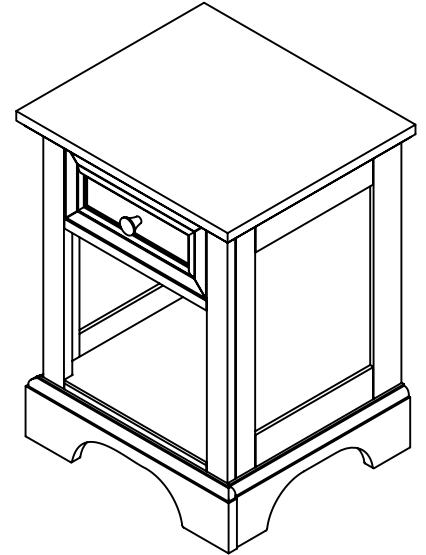

IMPORTANT NOTE

Carefully remove all the parts from the carton and put them individually on a soft cloth to prevent scratches or other damages occurring to the wood parts.

We have taken great care in the design of this product and request that you carefully and strictly follow our assembly instructions to ensure a completed product as it was designed.

Part List

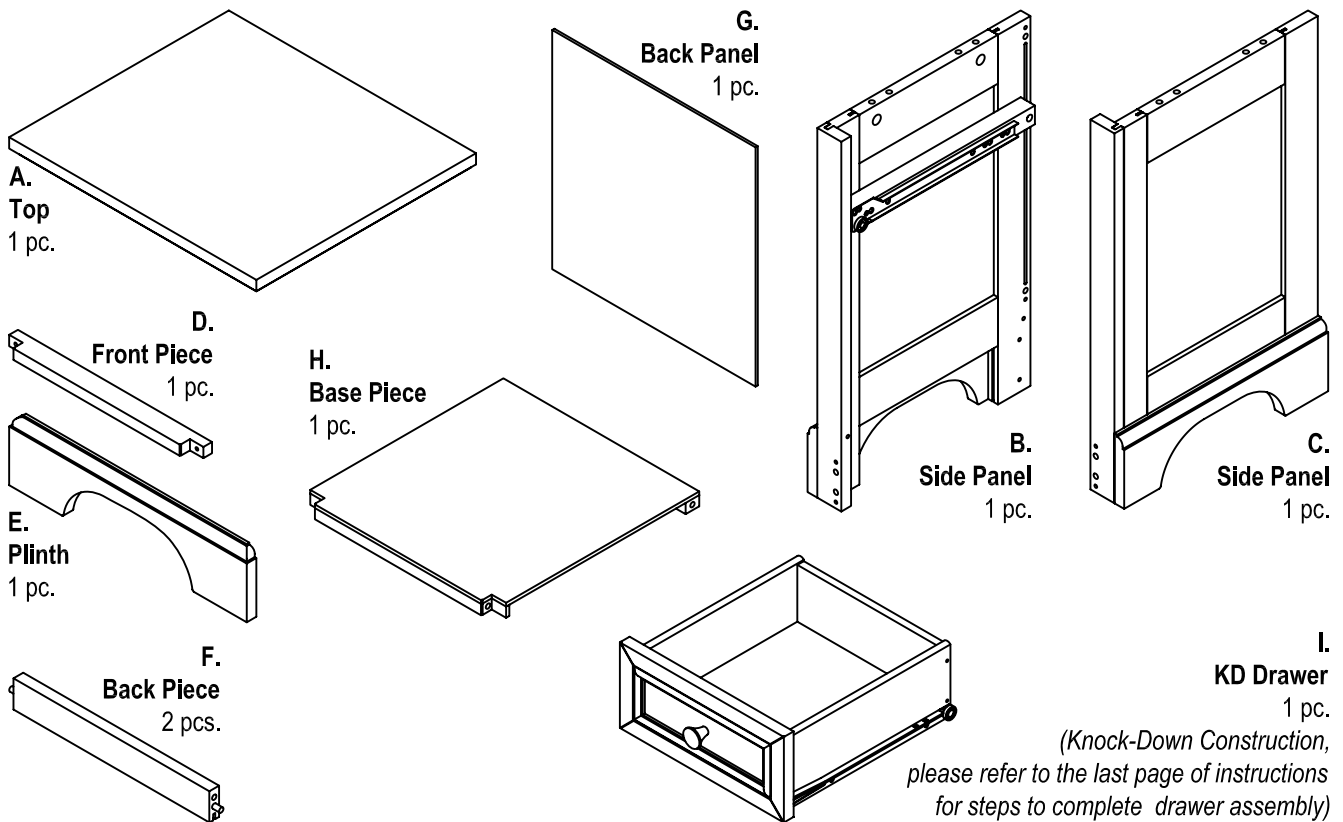

Hardware List

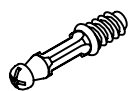

Cam Lock Screw
12 pcs. (+1 extra)



Cam Lock
12 pcs. (+1 extra)

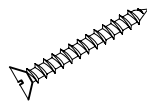

1/4" Flat Head Screw
8 pcs. (+1 extra)



3/4" Flat Head Screw
2 pcs. (+1 extra)

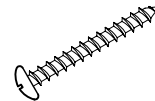

1 1/4" Round Head Screw
4 pcs. (+1 extra)

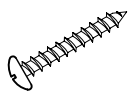

1" Round Head Screw
2 pcs. (+1 extra)



5/8" Round Head Screw
4 pcs. (+1 extra)



Machine Screw
1 pc.



Small Pull Handle
1 pc.



Wooden Dowel
8 pcs. (+1 extra)

Assembly Instructions 2/6

IMPORTANT

Do not tighten up all the screws until each part is properly assembled.

STEP 1

Insert Cam Lock Screws into the pre-drilled holes of Side Panel (B) and (C).

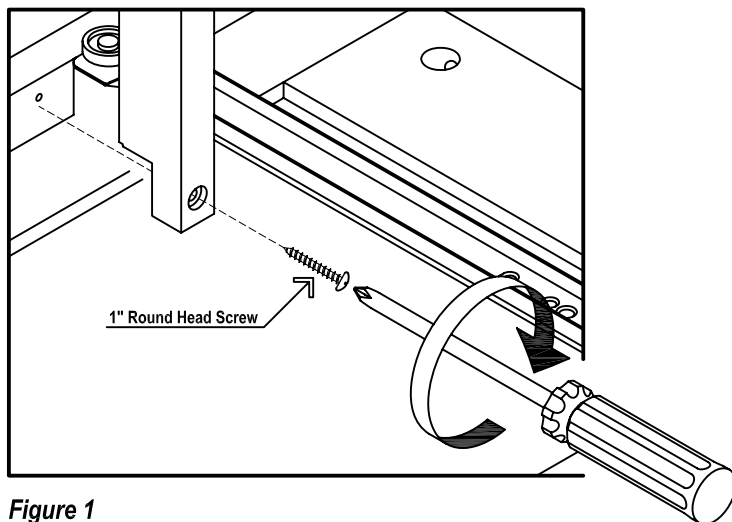
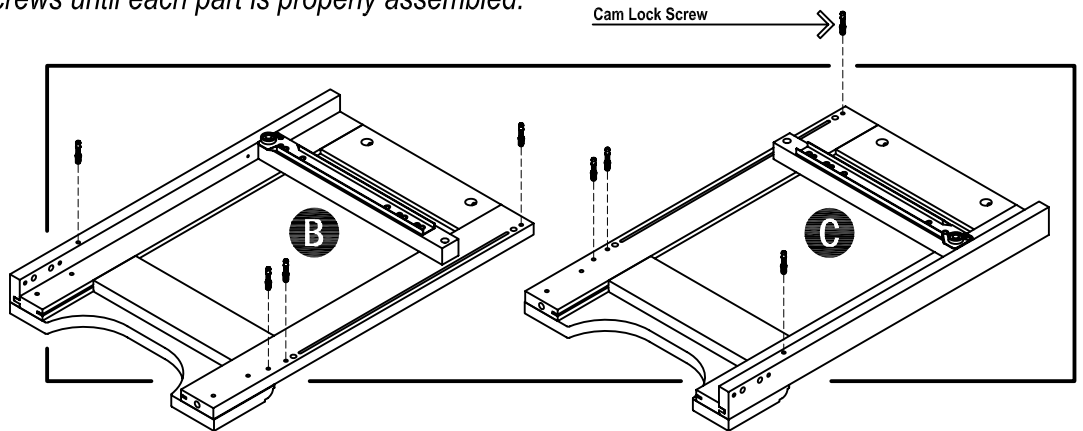
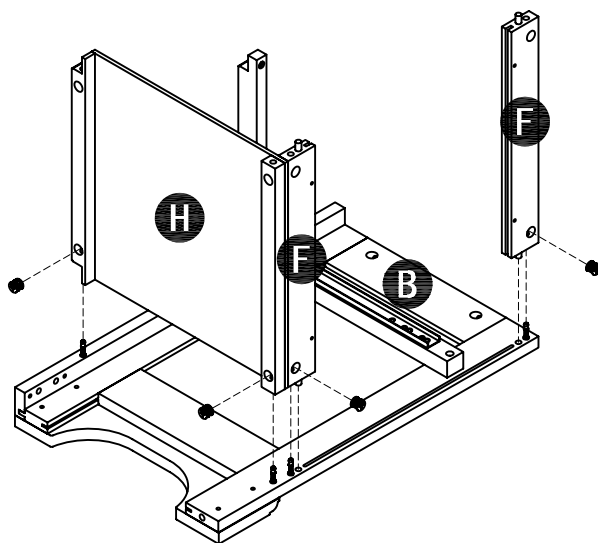

Figure 1

STEP 2

Attach Front Piece (D) to Side Panel (B) with 1" Round Head Screws. (See figure 1)



STEP 3

Attach Back Pieces (F) & Base Piece (H) to Side Panel (B) using Cam Locks. (See figure 2)

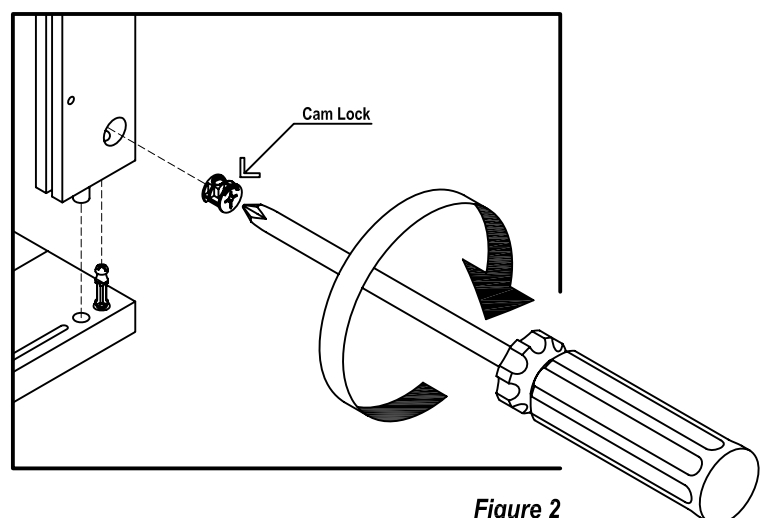

Figure 2

Assembly Instructions 3/6

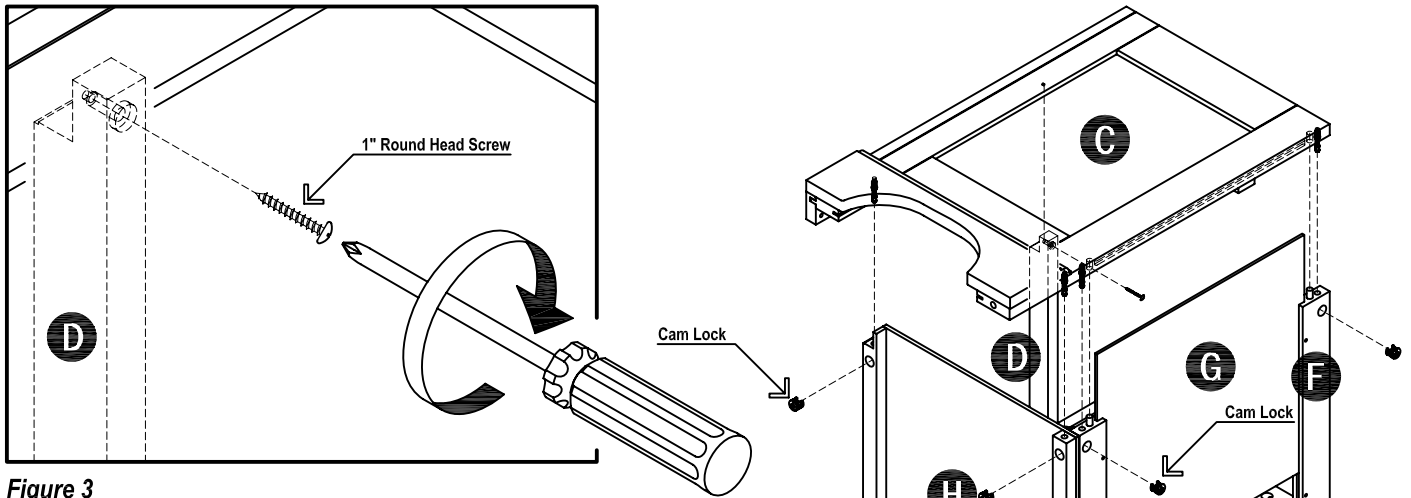

Figure 3

STEP 4

Slide Back Panel (G) into Back Piece's (F) grooves.

Attach Back Piece (F) & Base Piece (H) to Side Panel (C) using Cam Locks.

Attach Front Piece (D) to Side Panel (C) with 1" Round Head Screws. (See figure 3)

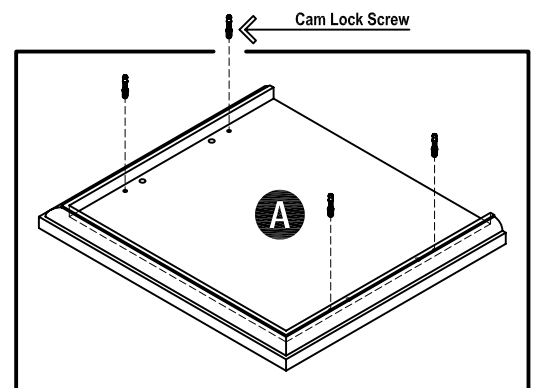
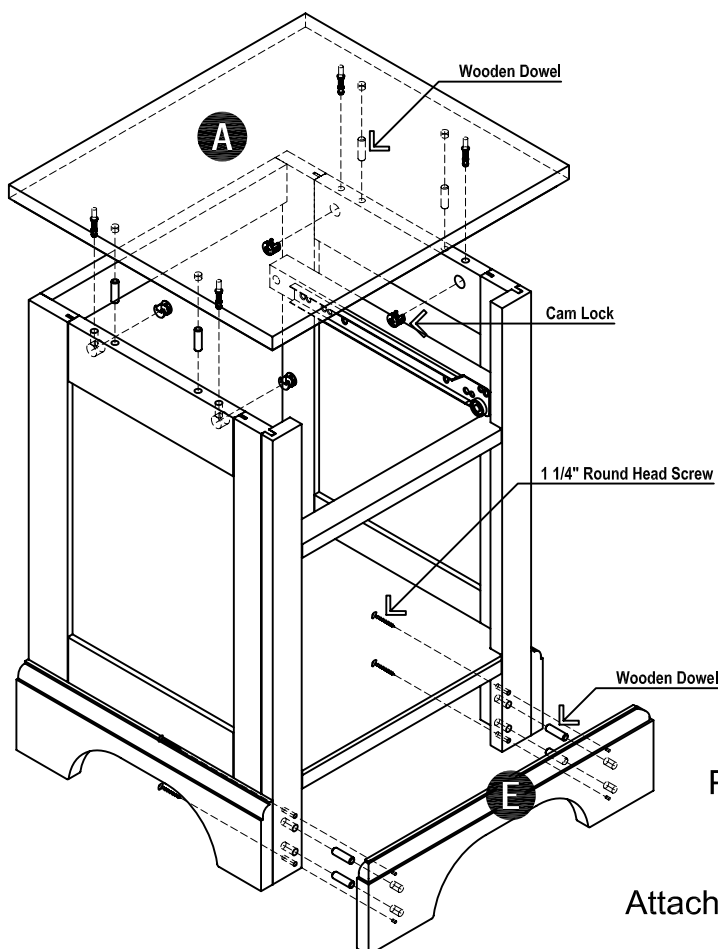

STEP 5

Insert Cam Lock Screws into the pre-drilled holes of Top (A).

STEP 6

Place Top (A) onto the unit using Cam Locks & Wooden Dowels.

Attach Plinth (E) to the unit using 1 1/4" Round Head Screws & Wooden Dowels.

Assembly Instructions 4/6

STEP 7

Attach 5/8" Round Head Screws to the back of unit through the holes of Back Piece (F).

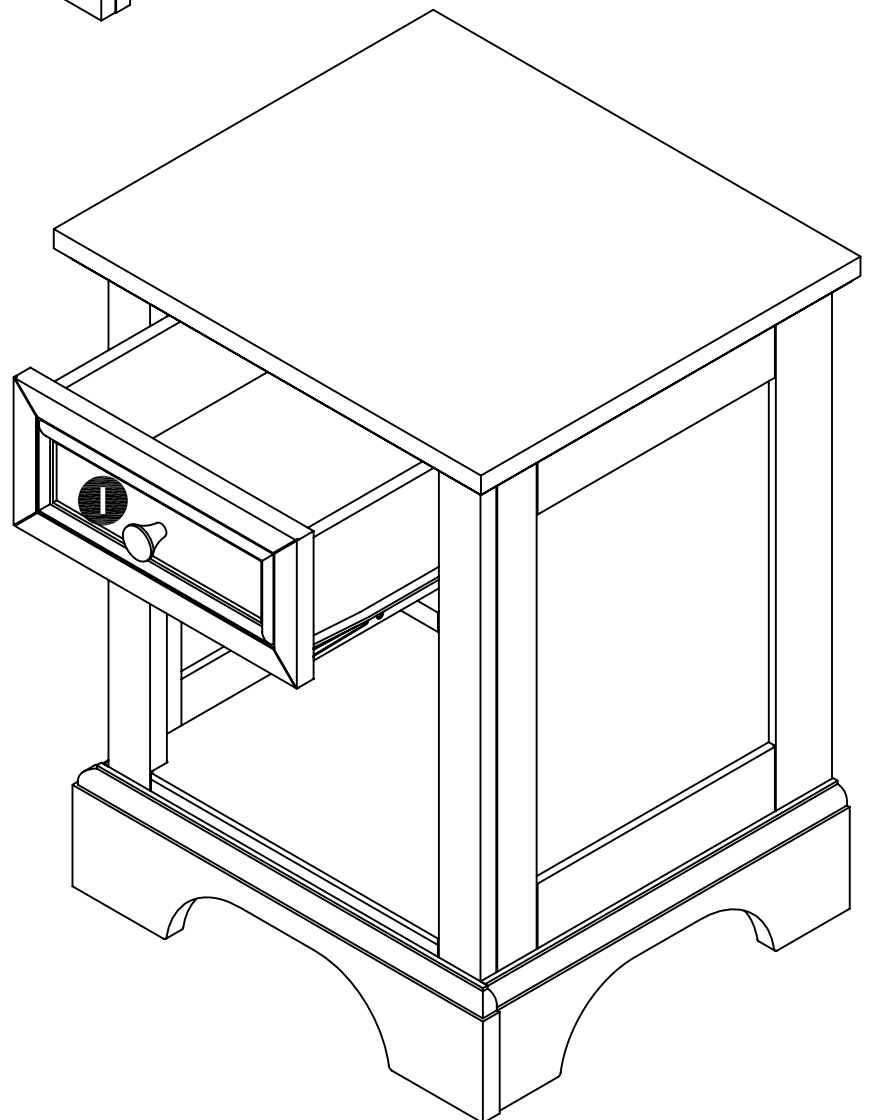
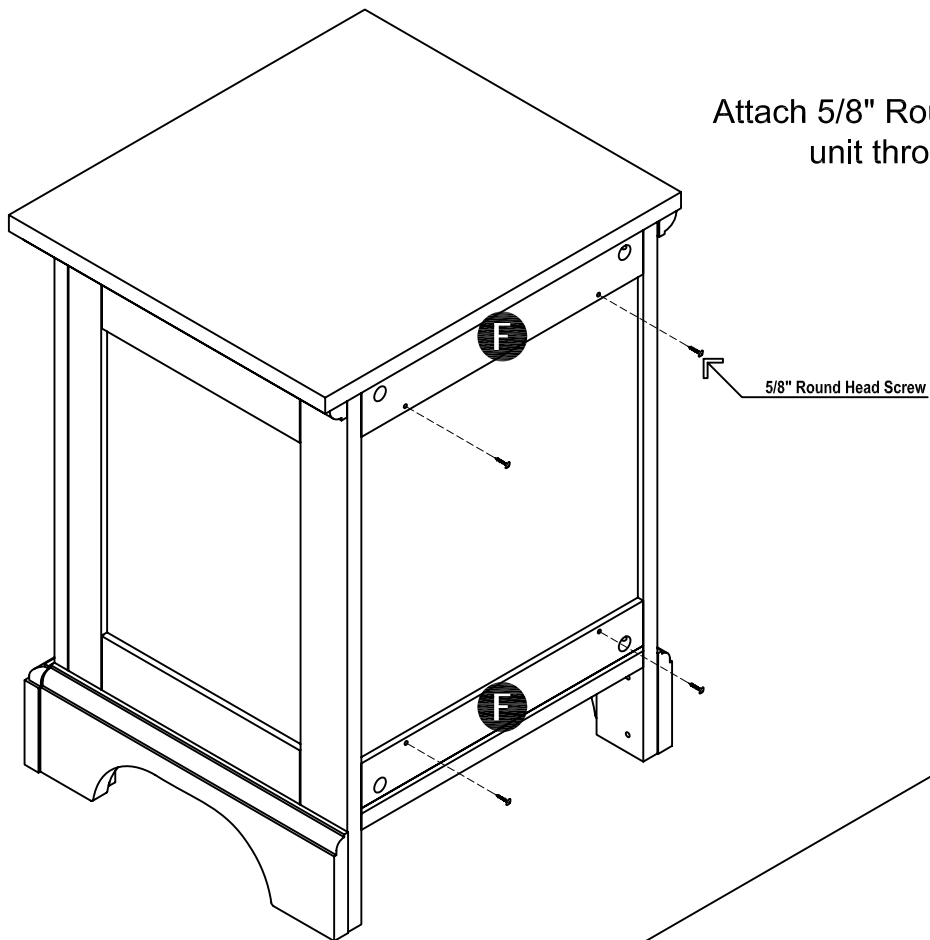

STEP 8

Insert the drawer (I) into unit.

Drawer (I)

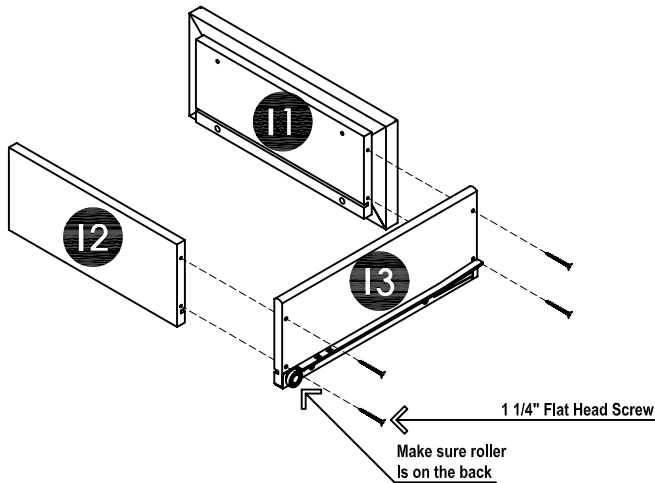

STEP 1

Attach Side Part (I3) to Front Part (I1) and Back Part (I2) using a Phillips screwdriver and 1 1/4" Flat Head Screws.

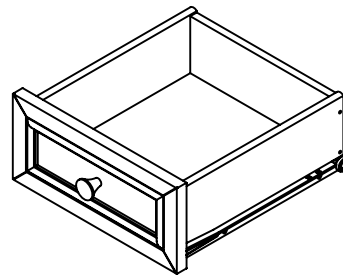

STEP 2

Insert Base Part (I5) into the groove.

Attach Side Part (I4) to Front Part (I1) and Back Part (I2) using a Phillips screwdriver and 1 1/4" Flat Head Screws.

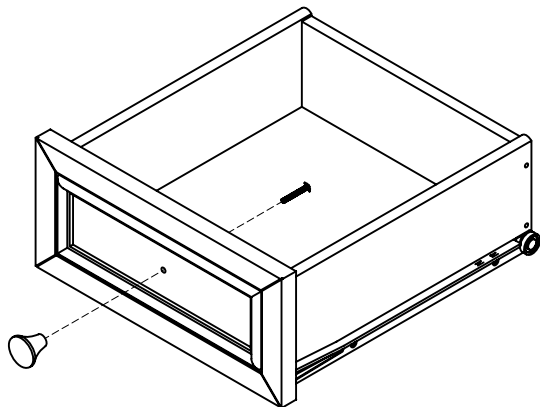
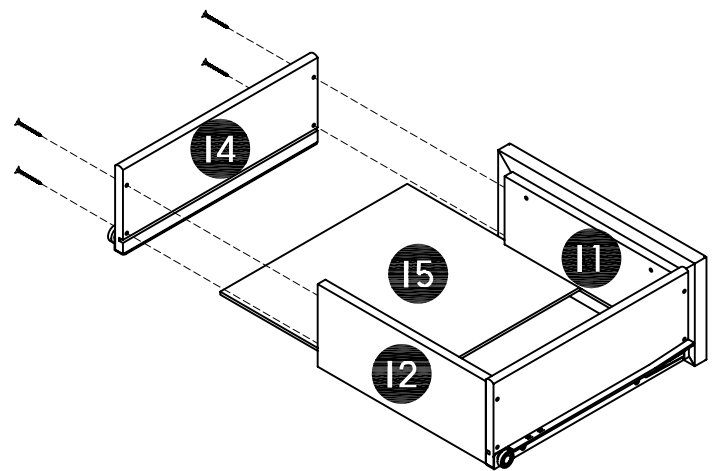

STEP 3

Attach Small Pull Handles with machine screws.

Part List

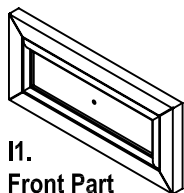

I1.
Front Part
1 pc.

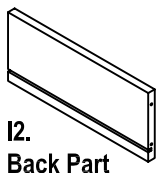

I2.
Back Part
1 pc.

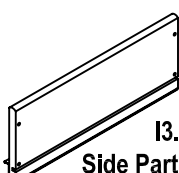

I3.
Side Part
1 pc.

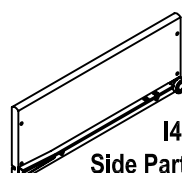

I4.
Side Part
1 pc.

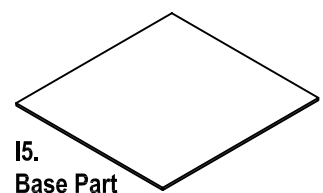

I5.
Base Part
1 pc.

Assembly Instructions 6/6

I. IF THE DRAWER DOES NOT ALIGN

STEP 1

Loosen slightly the lower screws.

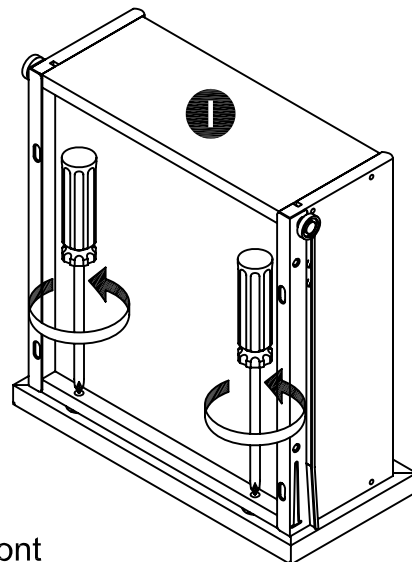

STEP 2

Insert the drawer into the main body, then adjust the drawer front panel left or right and up or down, until the drawer gaps look proportional.

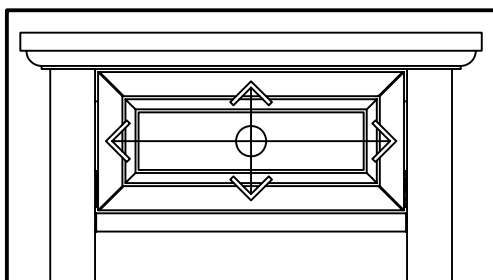
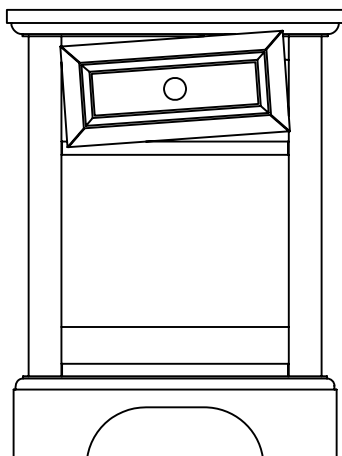

II. IF THE DRAWER ALREADY ALIGNS

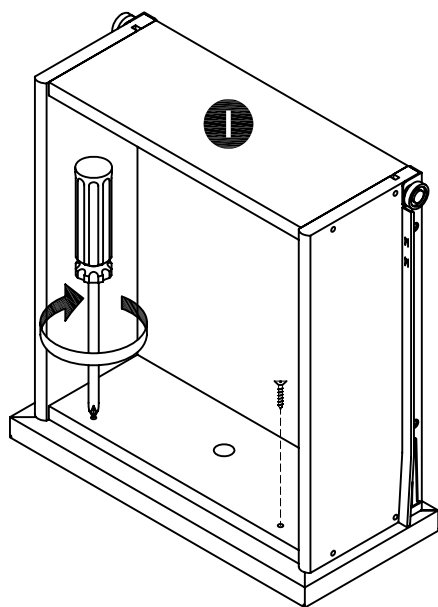

Pull out drawer slowly. Lock the drawer front panel into position with 3/4" Flat Head Screws.

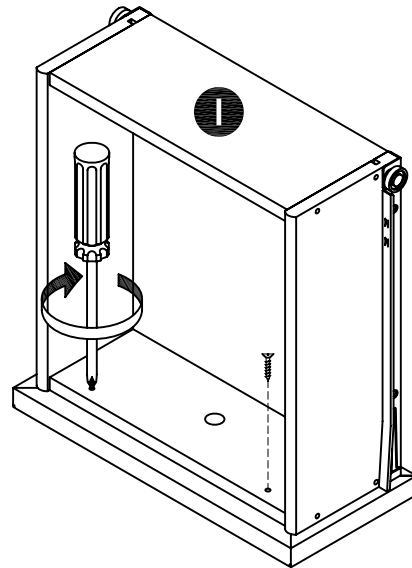
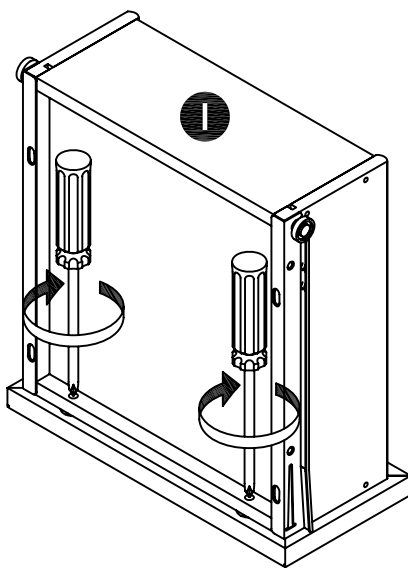

STEP 3

Pull the drawer open slowly and tighten the upper screws. Make sure the front panel does not move and lock the drawer front panel into position with 3/4" Flat Head Screws.