

ASSEMBLY INSTRUCTIONS



TALL CABINET

ASSEMBLY INSTRUCTIONS

ASSEMBLY TIPS:

1. Remove hardware from box and sort by size.
2. Please check to see that all hardware and parts are present prior to start of assembly.
3. Please follow attached instructions in the same sequence as numbered to assure fast & easy assembly.



WARNING!

1. Don't attempt to repair or modify parts that are broken or defective. Please contact the store immediately.
2. This product is for home use only and not intended for commercial establishments.



ASSEMBLY TIME

50 MINUTES

PARTS IDENTIFICATION

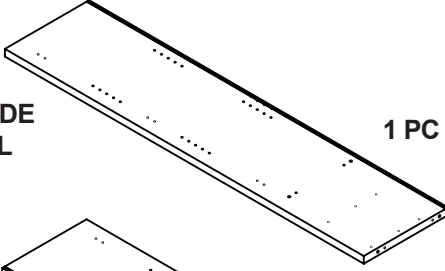
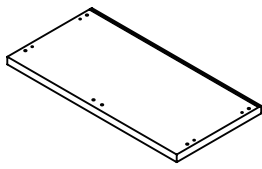
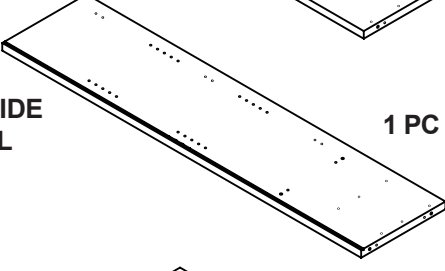
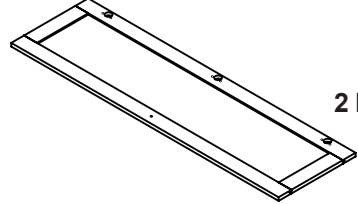
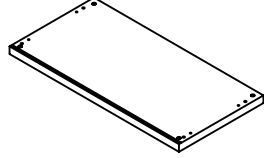
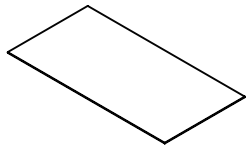
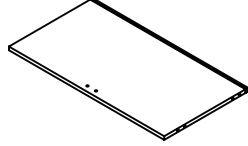
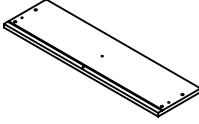
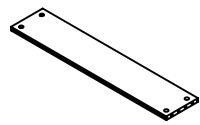
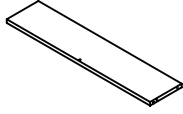
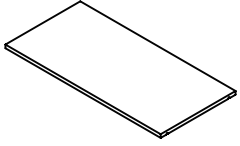
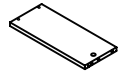
| | | | | | | | |
|---|-------------------|---|-------|---|------------------------|---|-------|
| A | LEFT SIDE PANEL |  | 1 PC | G | TOP PANEL |  | 1 PC |
| B | RIGHT SIDE PANEL |  | 1 PC | H | DOOR |  | 2 PCS |
| C | BOTTOM PANEL |  | 1 PC | I | UPPER BACK PANEL |  | 3 PCS |
| D | LOWER CROSS PANEL |  | 1 PC | J | DRAWER FRONT PANEL |  | 2 PCS |
| E | BACK BRACE |  | 1 PC | K | DRAWER BACK PANEL |  | 2 PCS |
| F | ADJUSTABLE SHELF |  | 2 PCS | L | LEFT DRAWER SIDE PANEL |  | 2 PCS |

NOTE:

Phillips head screw driver is required in the assembly process; however, manufacturer does not provide this item.

M RIGHT DRAWER SIDE PANEL

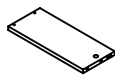

2 PCS

O DRAWER BOTTOM PANEL

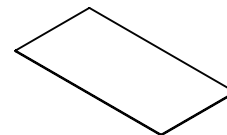

2 PCS

N DRAWER SUPPORT



2 PCS



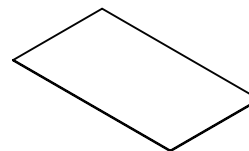







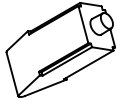



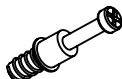
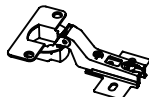

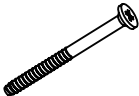

P DOWN BACK PANEL

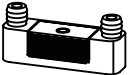

1 PC

Z

HARDWARE IDENTIFICATION

| NO | DESCRIPTION | FIGURE | Q'TY | NO | DESCRIPTION | FIGURE | Q'TY |
|----|----------------------------|---|--------|----|-------------------------|---|--------|
| 1 | GLUE 40g |  | 1 PC | 11 | HANDLE |  | 4 PCS |
| 2 | WOODEN DOWEL Ø 8x30mm |  | 24 PCS | 12 | HANDLE BOLT |  | 4 PCS |
| 3 | CAM BOLT Ø 7x35.5mm |  | 14 PCS | 13 | HINGE |  | 6 PCS |
| 4 | CAM LOCK Ø 15x12mm |  | 14 PCS | 14 | HINGE SCREW Ø 4x15mm |  | 24 PCS |
| 5 | BOLT Ø 9.5x55mm |  | 8 PCS | 15 | FOOT |  | 4 PCS |
| 6 | DRAWER SCREW Ø 4.3x35mm |  | 10 PCS | 16 | FOOT BOLT M6x42mm |  | 4 PCS |
| 7 | PIN Ø 4.9x8mm |  | 8 PCS | 17 | FIXER |  | 6 PCS |
| 8 | DOOR CATCH |  | 2 PCS | 18 | FIXER SCREW Ø 3x19mm |  | 6 PCS |
| 9 | GLIDES L = 350mm |  | 2 SET | 19 | PLASTIC BACK BRACE |  | 1 PC |
| 10 | GLIDES SCREW Ø 3x12mm |  | 24 PCS | 20 | STICKER Ø 20mm |  | 3 PCS |

Z9,Z11,Z12,Z13,Z15,Z19 not included in blister packaging.

NOTE:

Phillips head screw driver is required in the assembly process; however, manufacturer does not provide this item.

STEP 1

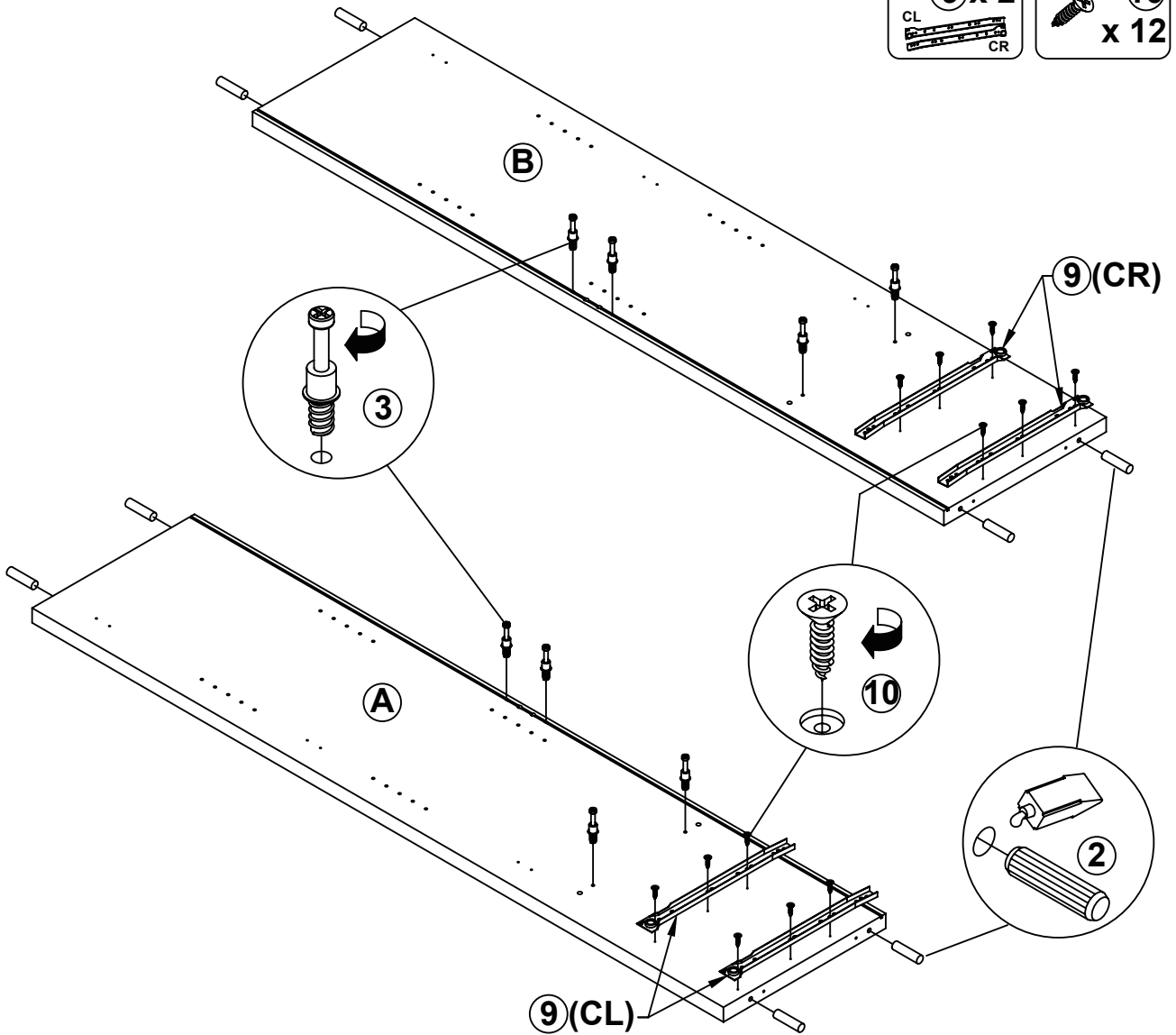
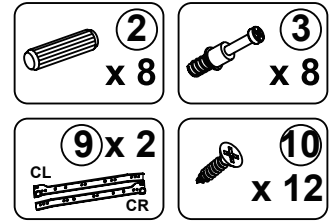

INCORRECT
CORRECT

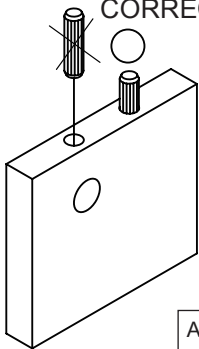

Apply glue on all wooden dowels to ensure integrity of the structure.

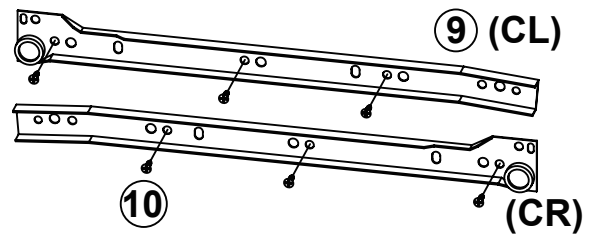

STEP 2

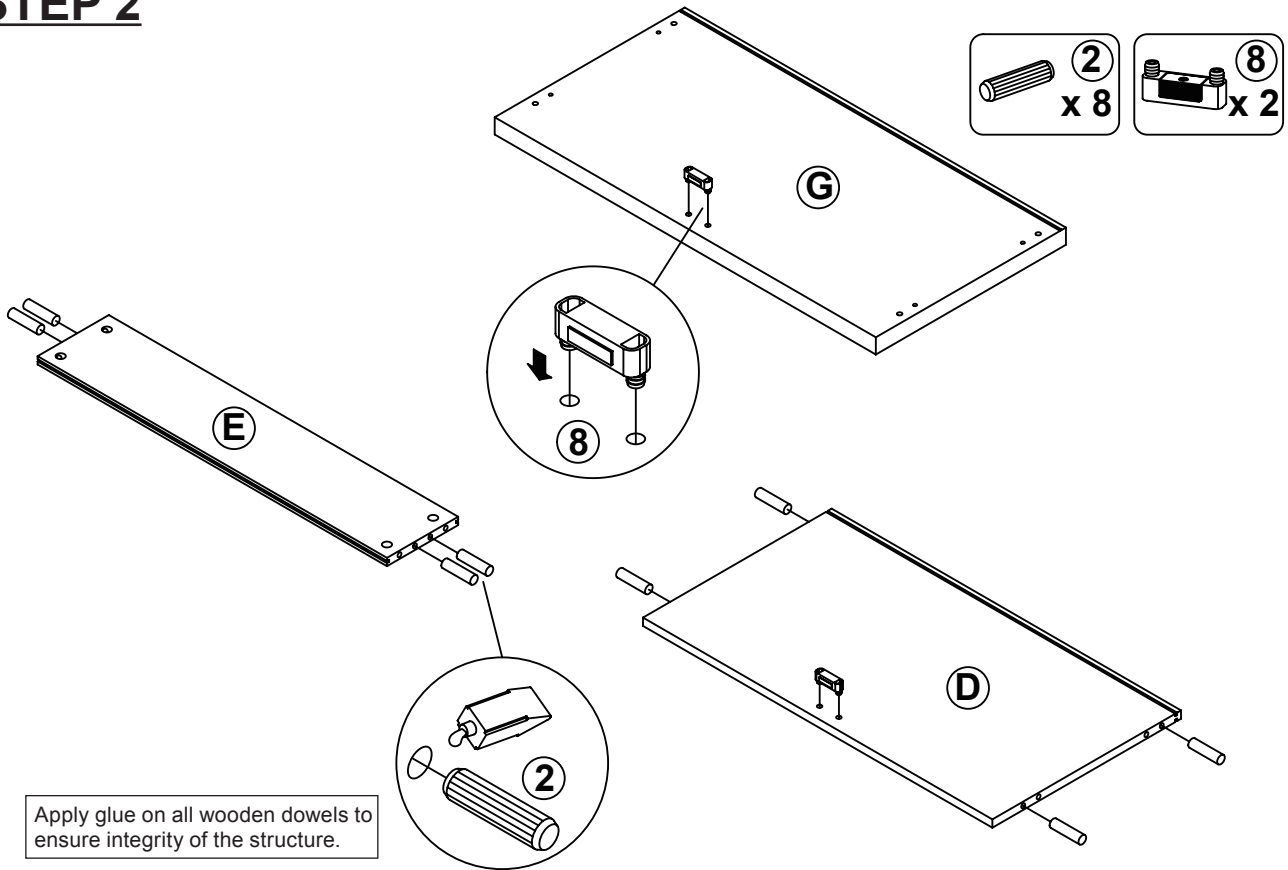

STEP 3

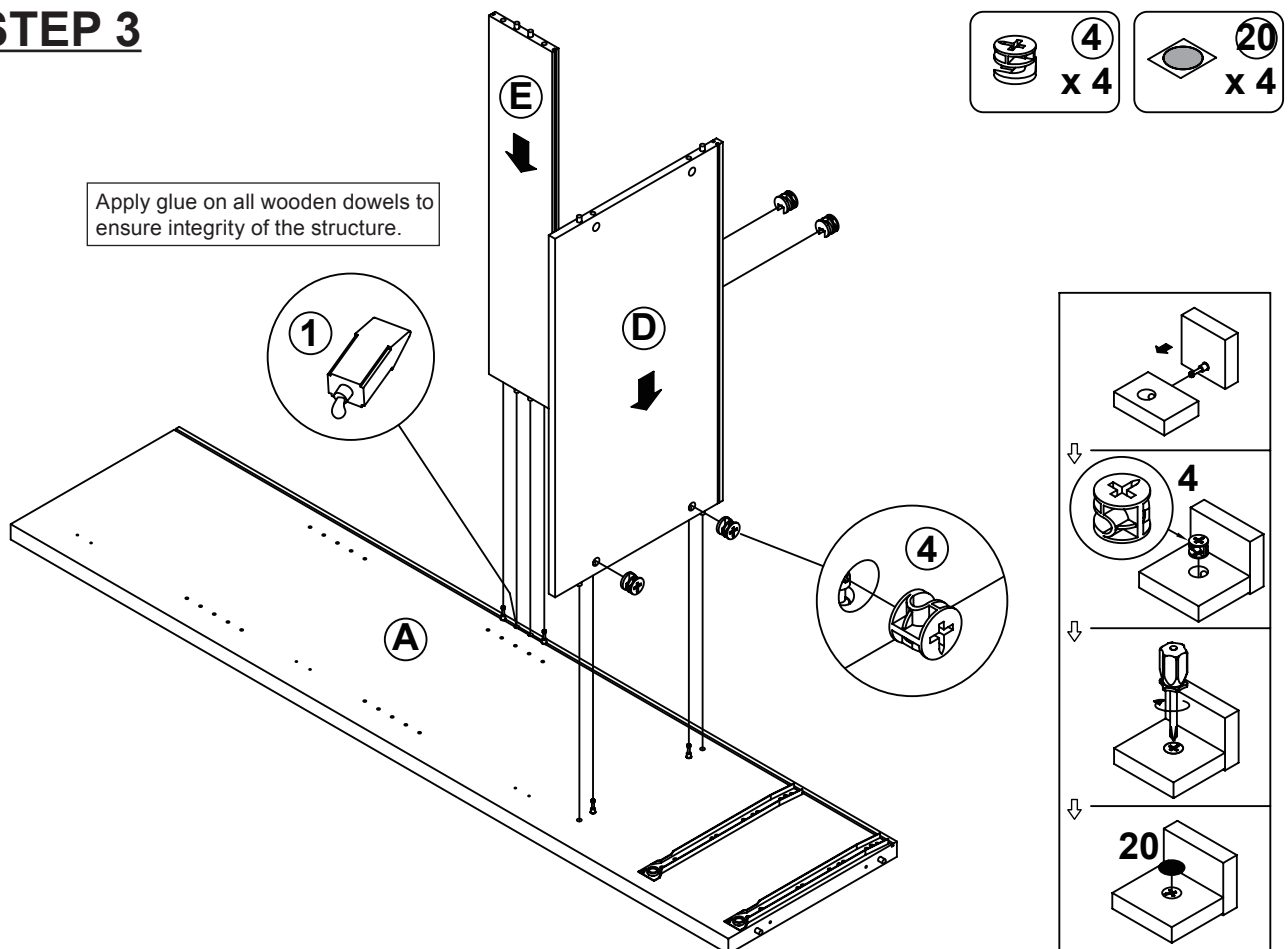

STEP 4

Apply glue on all wooden dowels to ensure integrity of the structure.

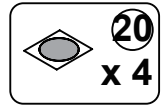
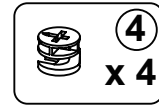
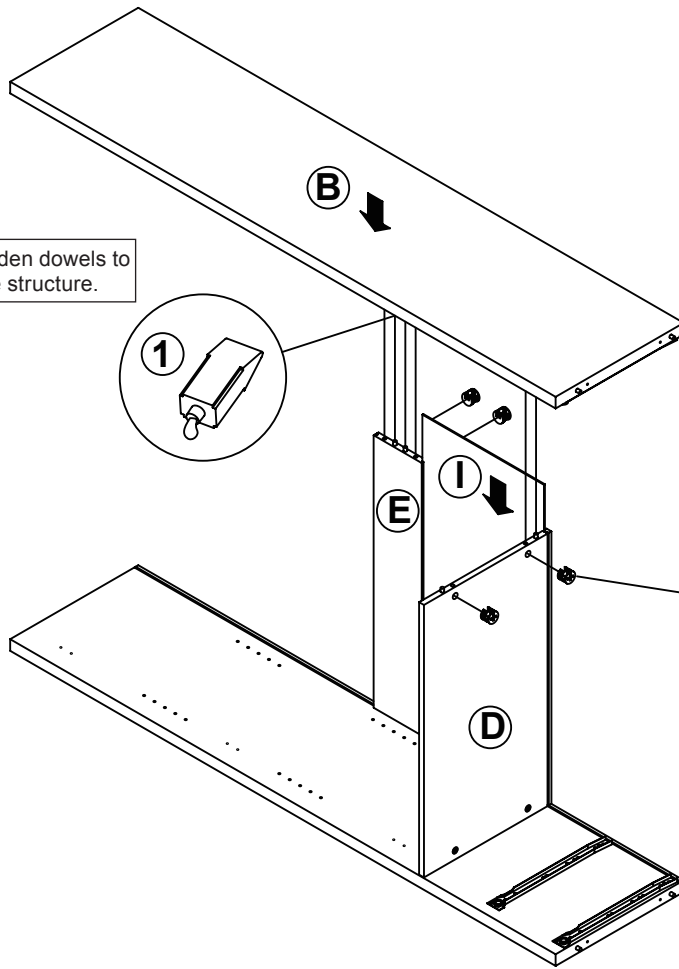

STEP 5

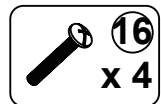
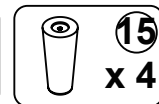
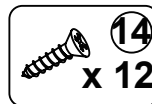
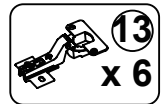
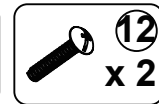
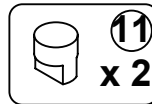
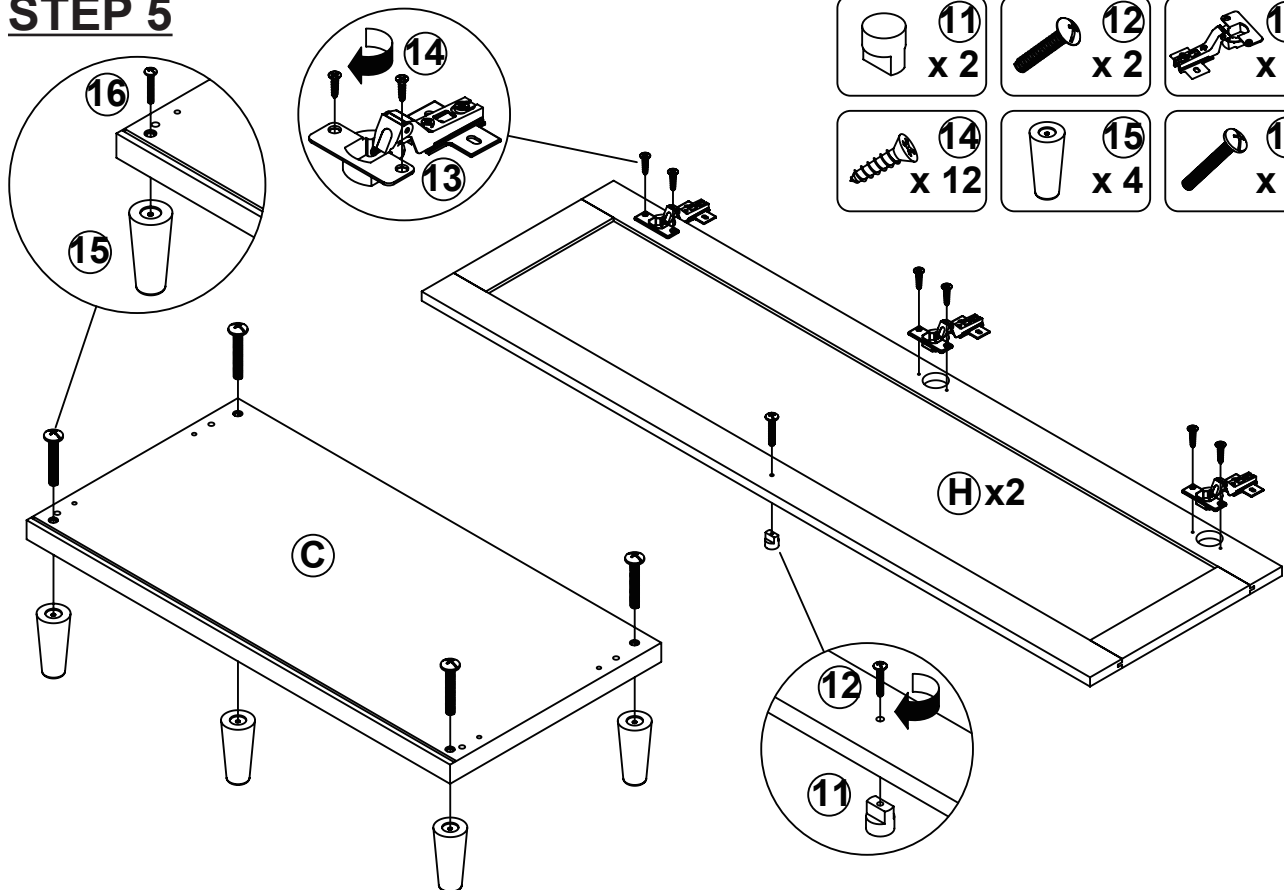

STEP 8

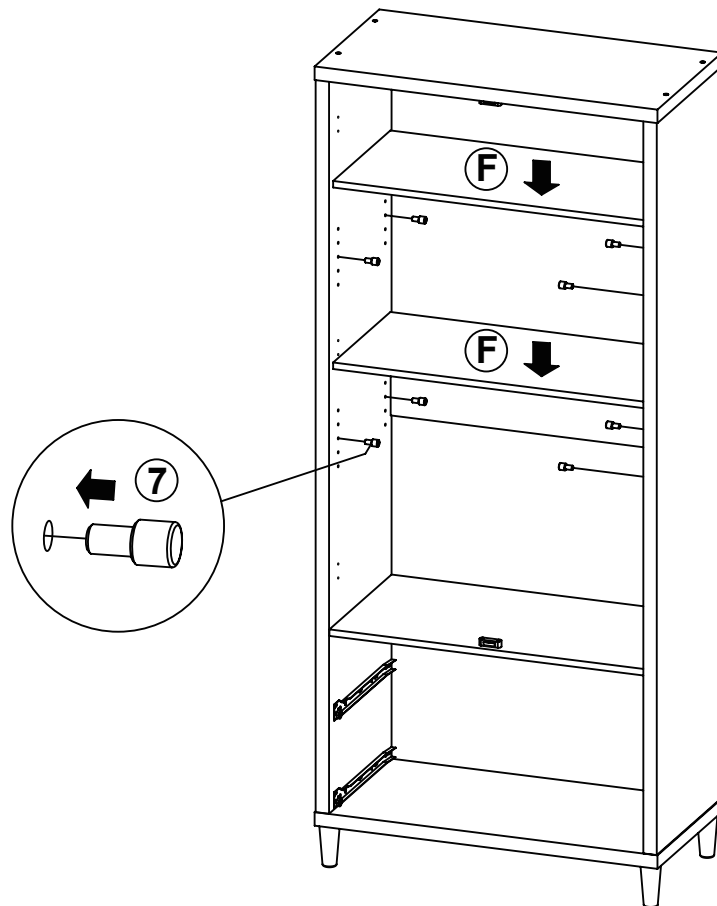

STEP 9

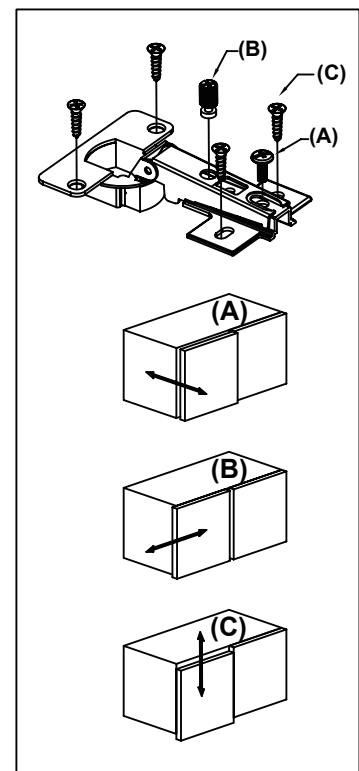
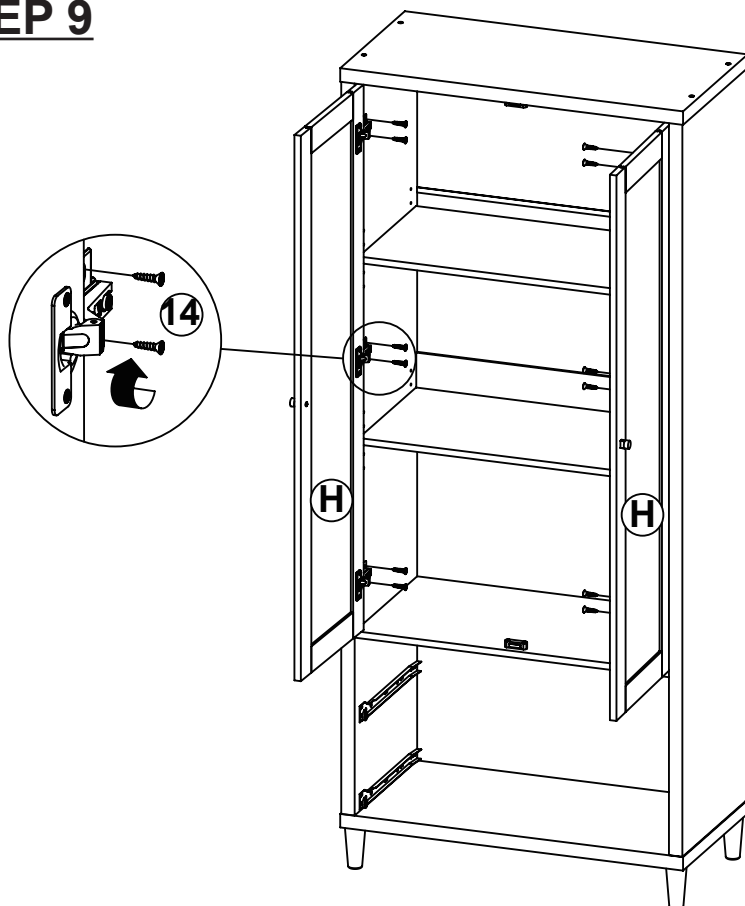

STEP 10-1

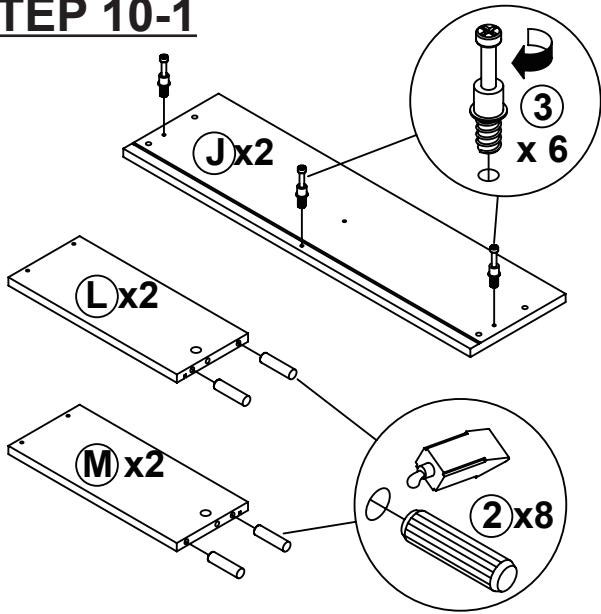

STEP 10-2

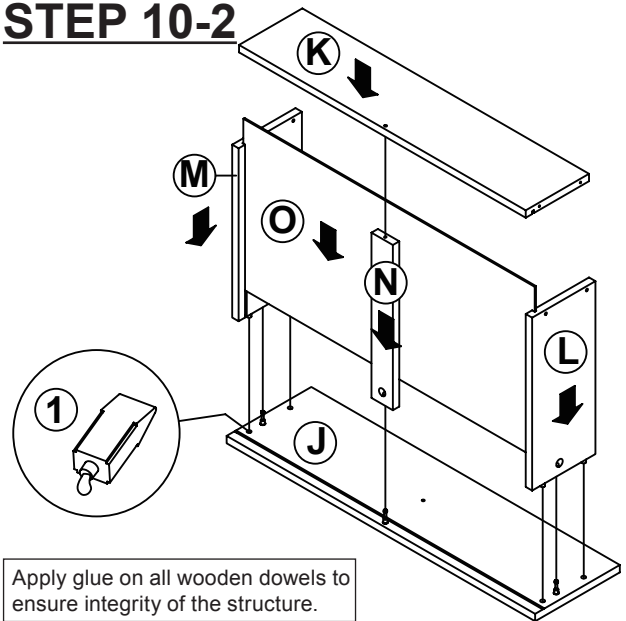

STEP 10-3

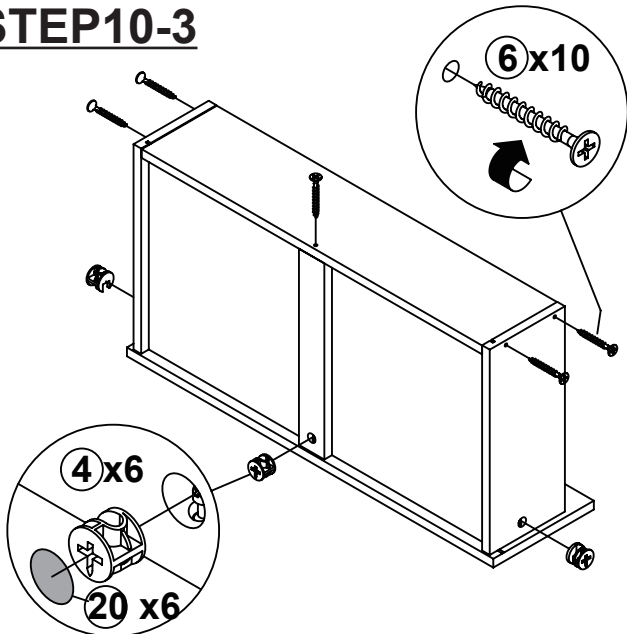

STEP 10-4

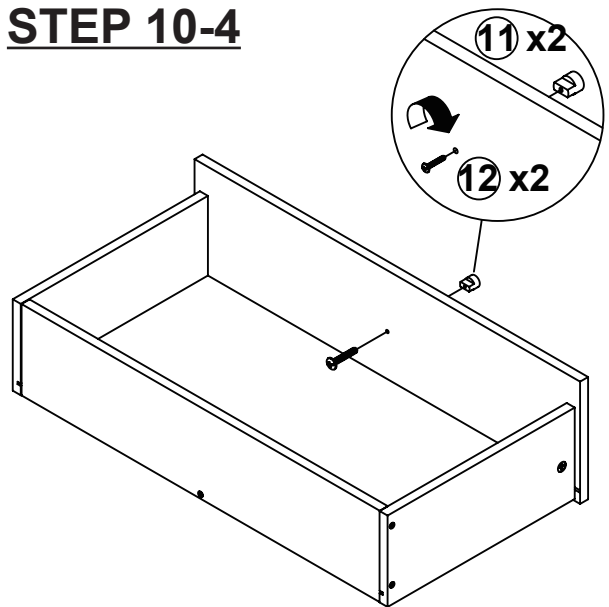

STEP 10-5

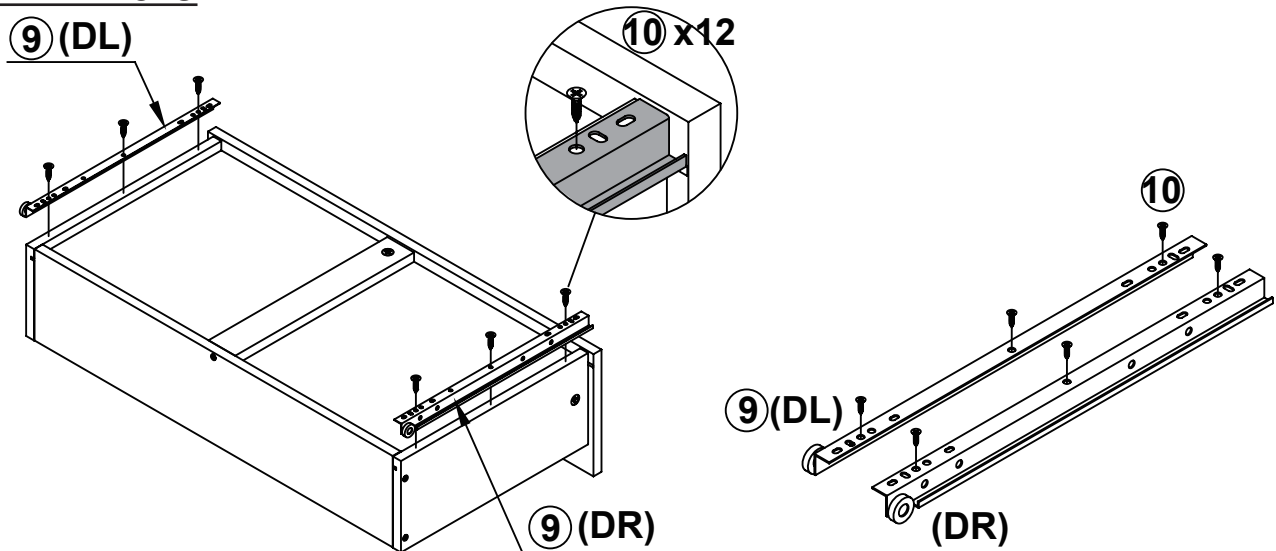

STEP 11

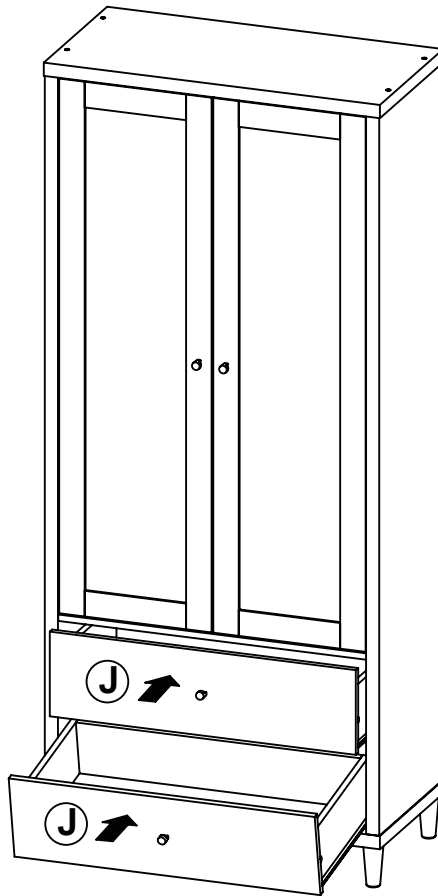

STEP 12

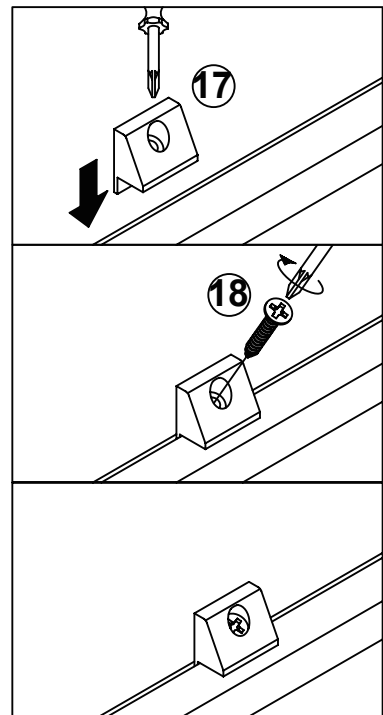
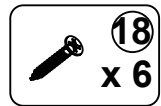
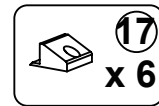
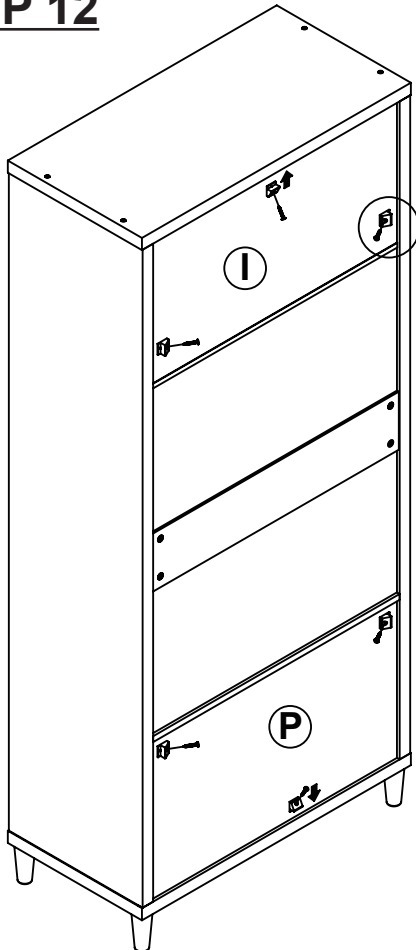

STEP 13
COMPLETE

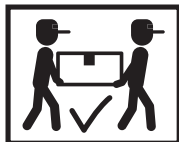
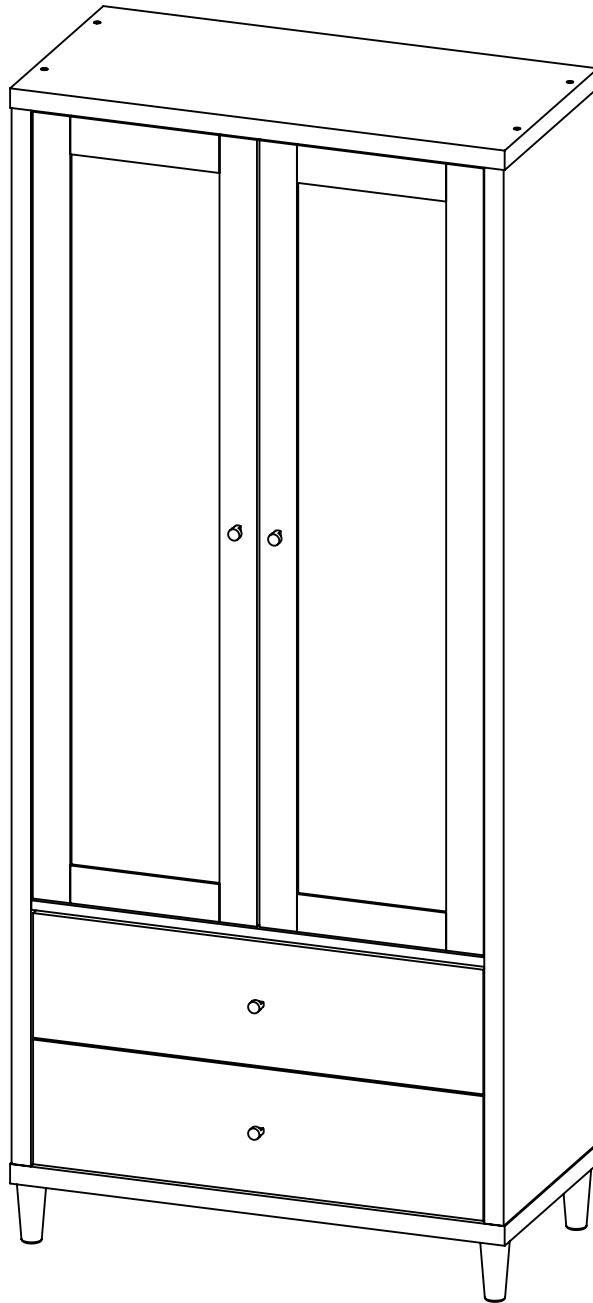

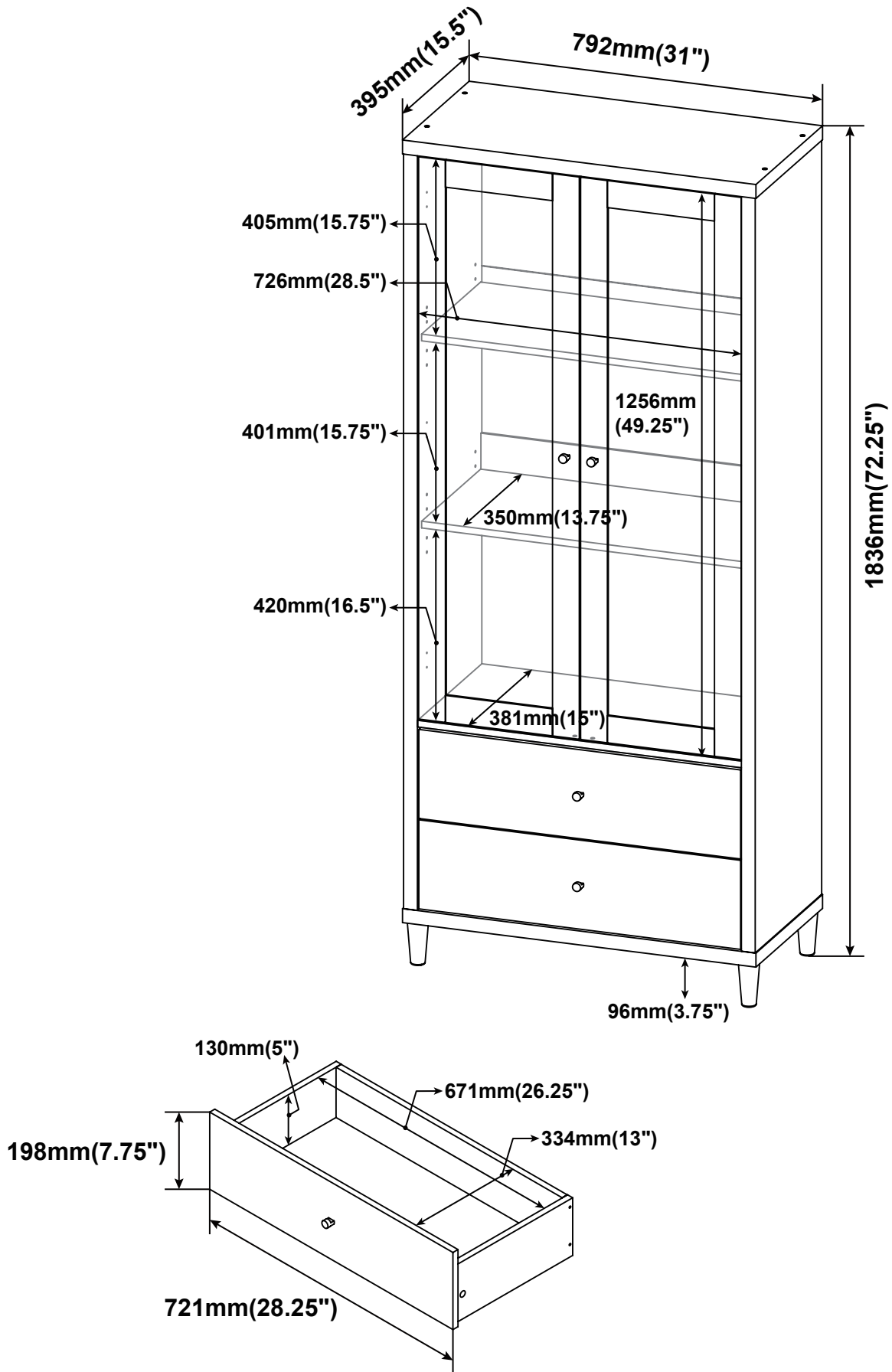

Note : Dimension tolerance $\pm 5\%$

ANTI-TIPPING INSTALLMENT INSTRUCTIONS

FURNITURE TIPPING RESTRAINT

WARNING

Injury may result from tipping furniture.
This restraint may protect against tipping furniture.
Do not allow children to climb on furniture.
This restraint is not a substitute for proper adult supervision.
Failure to detach this restraint before moving the furniture
may result in injury and damage.

1. To attach the anti-tip strap, securely mount one end to the top of the case piece with the 5/8" screw.
2. Position the case piece against the wall in the desired location.
3. Pull the anti-tip strap taut and mark the position of where you will secure the other end on the wall.
4. Drill a 1-1/4" hole in the spot you marked.
5. Tap in plastic wall plug.
6. Fasten anti-tip strap with wall screw provided.

(Please install the anti-tipping kit in the middle of the case piece if only have one set of anti-tipping kit.)

