

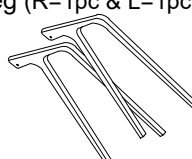









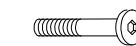

ASSEMBLY INSTRUCTIONS

ITEM	HARDWARE NAME	QTY	ITEM	HARDWARE NAME	QTY
1	Leg (R=1pc & L=1pc) 	2 PCS	A	JCBC BOLT M6 X 50 mm 	8 PCS
			B	JCBC BOLT M6 X 35 mm 	2 PCS
			C	SPRING WASHER M6 	8 PCS
2	Back Rest 	1 PC	D	WOOD DOWEL M8x30mm 	2 PCS
			E	CSK SCREW M4 x 12 mm 	8 PCS
3	Cushion Seat 	1 PC	F	Wood Button 	2 PCS
			G	ALLEN KEY M4 	1 PC
4	Apron 	2 PCS	H	BRACKET 	4 PCS

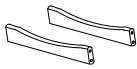

FULLY SET-UP

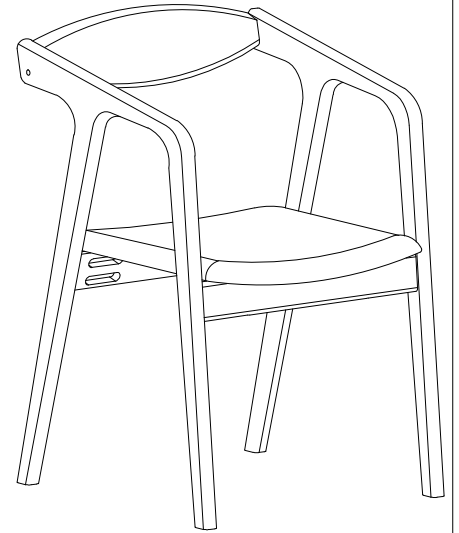
Step 1

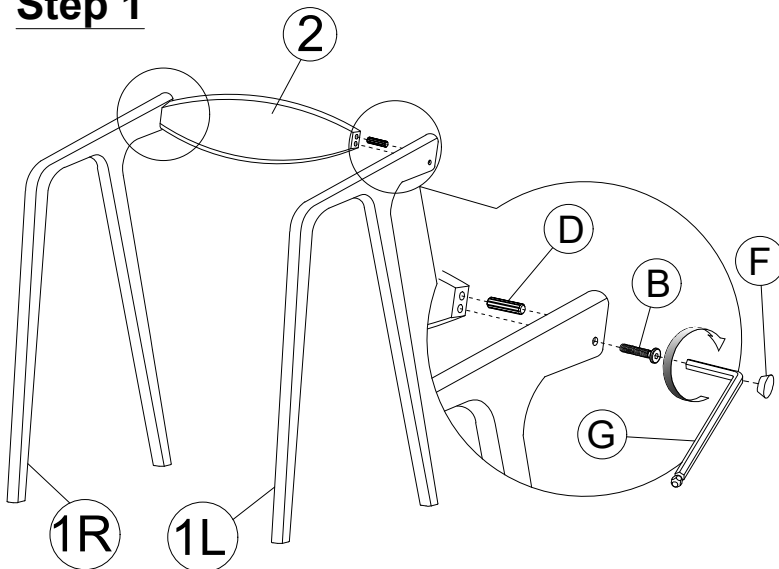

Step 2

MARKING

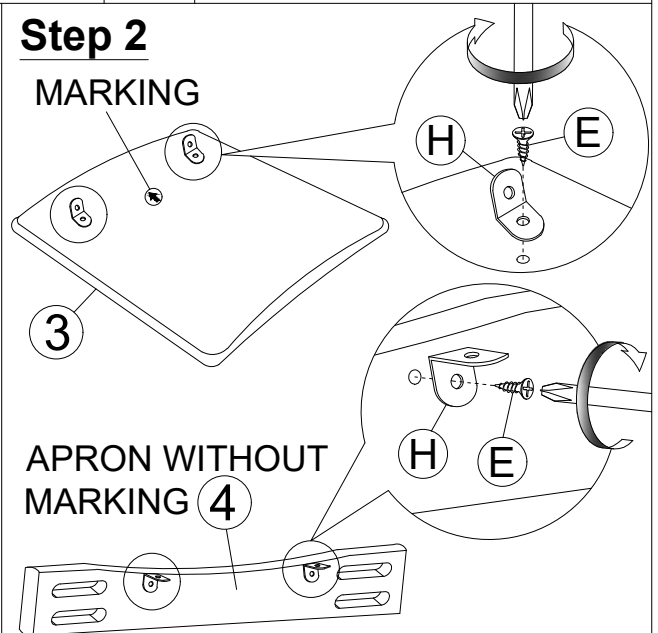

APRON WITHOUT MARKING 4

Step 3

APRON WITHOUT BRACKET 4

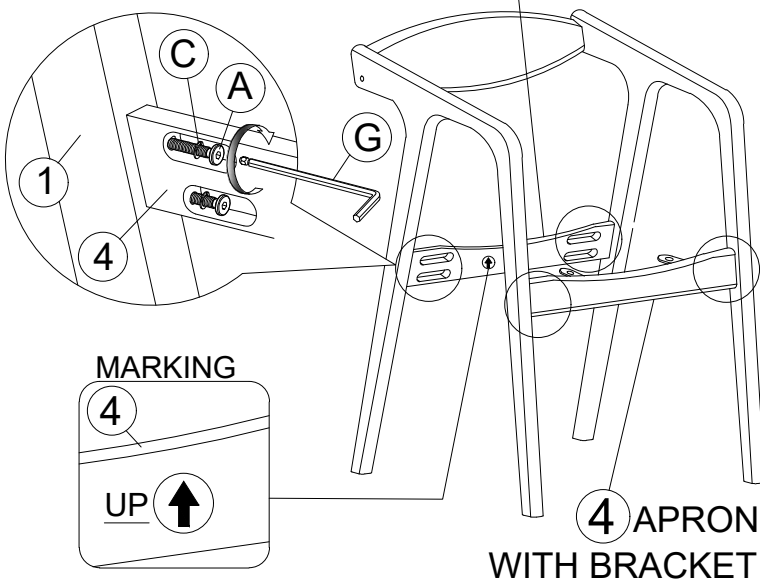

MARKING

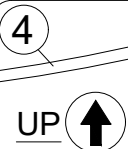

4 APRON WITH BRACKET

Step 4

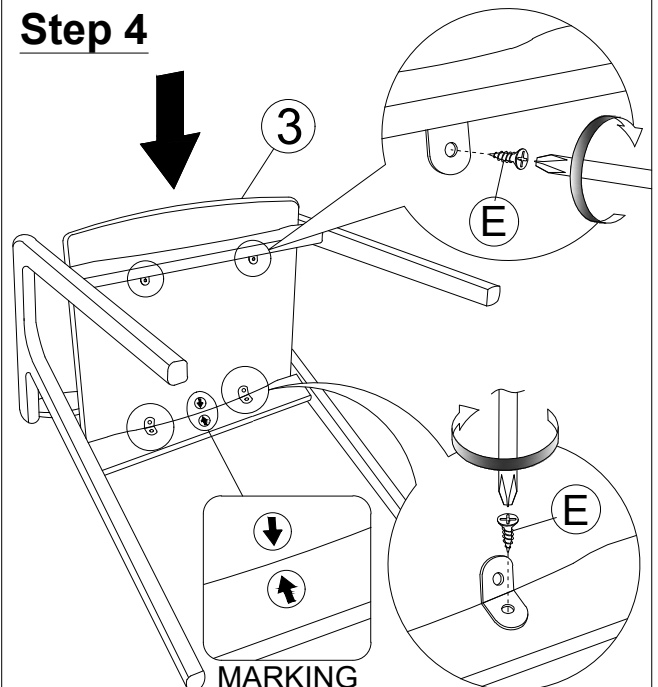

MARKING