

## Assembly Instructions

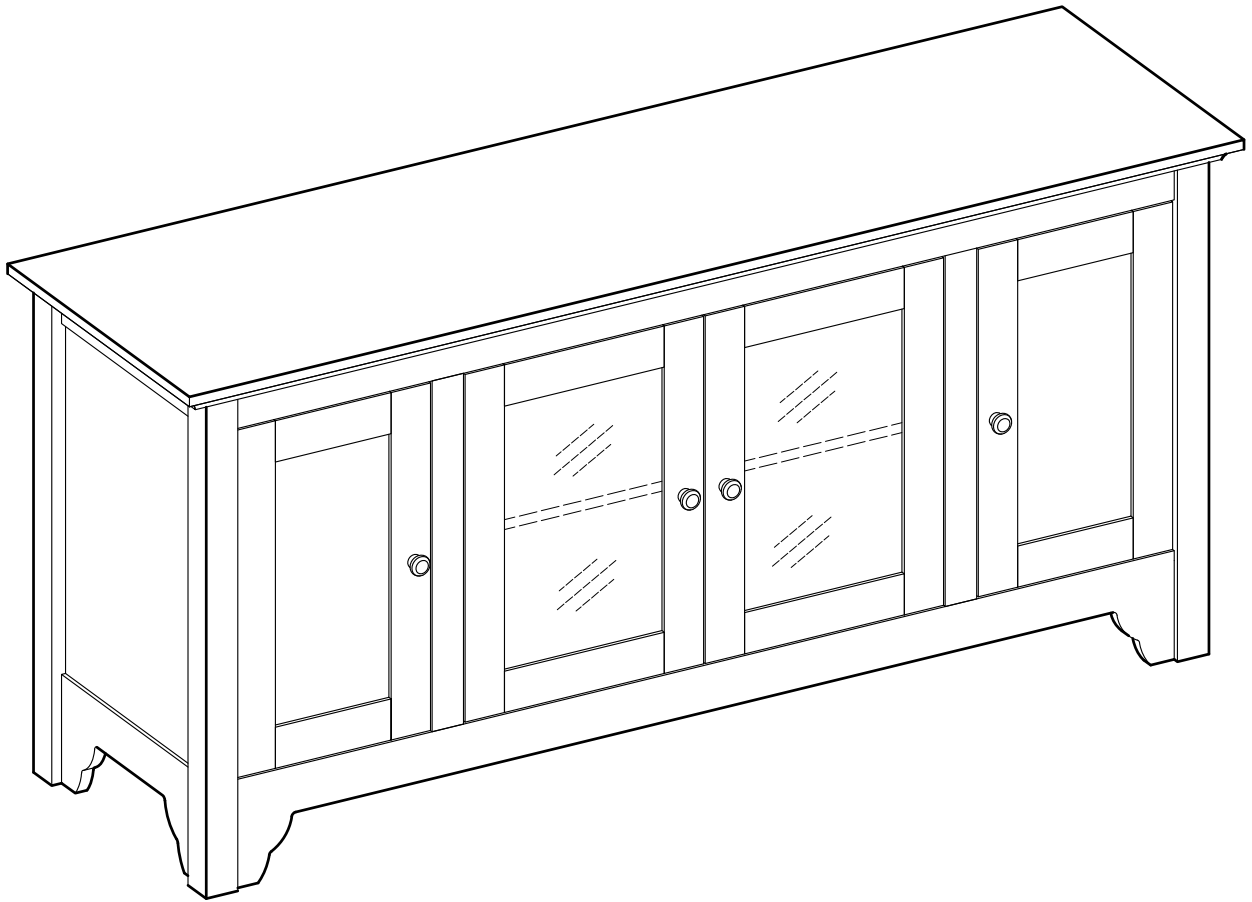

# General Assembly Guidelines

- I. Insure that all parts and hardware are available before beginning assembly.
- II. Follow each step carefully to insure the proper assembly of this product.
- III. Two people are recommended for ease in the assembly of this product.
- IV. The four main types of hardware used to assemble this product are wood dowels, cam bolts and locks, bolts and screws.
- V. The provided glue is to secure wood dowels in place. When first inserting dowels, locate the appropriate hole for the dowel, place a small amount of glue in the hole and insert the dowel. Wipe away excess glue immediately.

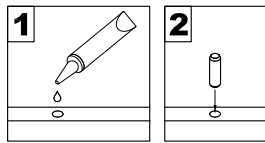

In future assembly steps when dowels are necessary to attach assembly parts together, place a small amount of glue on the end of the dowel before attaching parts together. Wipe away excess glue immediately.

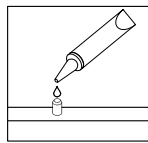

- VI. A Phillips head screwdriver is required for the assembly of this product.

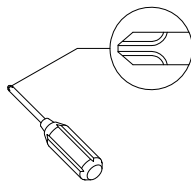



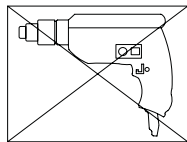



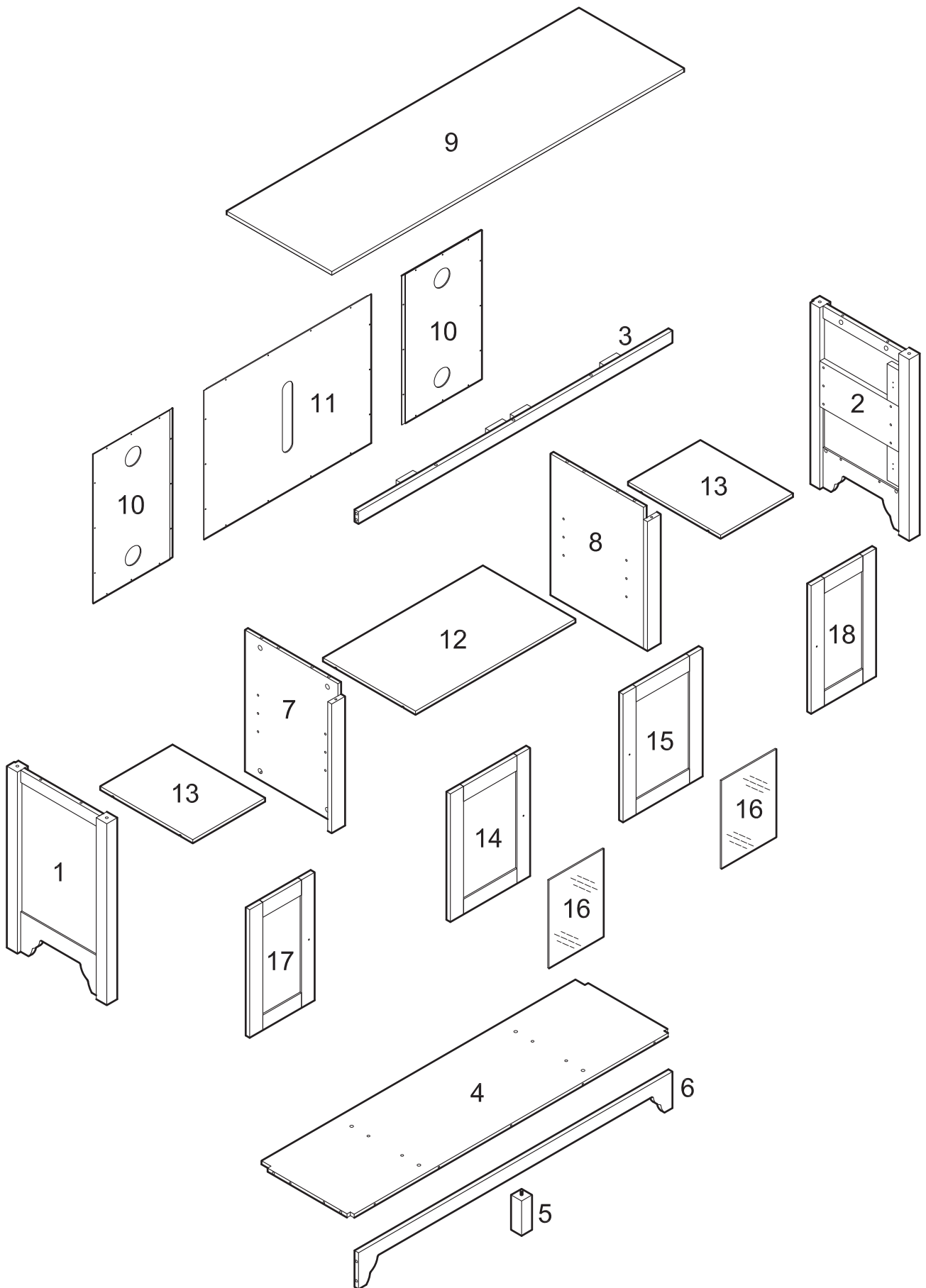



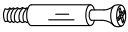
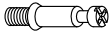

- VII. Power tools should not be used to assemble this product.



# Parts List

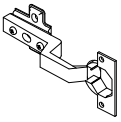

# Hardware List

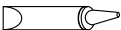
|   |   |               |                    |        |
|---|---|---------------|--------------------|--------|
| A |    | Ø8x30         | Large wooden dowel | 10 pcs |
| B |    | Ø6x30         | Small wooden dowel | 16 pcs |
| C |    | Ø6x32         | Cam bolt           | 21 pcs |
| D |    | Ø8x30mm       | Cam bolt           | 3 pcs  |
| E |    | Ø15x9.5       | Cam lock           | 24 pcs |
| F |    | Ø8x5x16       | Shelf support pin  | 12 pcs |
| G |    | Ø24x21        | Handel             | 4 pcs  |
| H |  | Ø9x5/32"x3/4" | Bolt               | 4 pcs  |
| J |  | Ø12x0.5       | Metal washer       | 12 pcs |
| K |  |               | Hinge              | 8 pcs  |
| L |  | Ø6.5x3x12     | Large screw        | 32 pcs |
| M |  | Ø4x2x8        | Small screw        | 12 pcs |
| N |  | Ø7x2.5x12     | Screw              | 32 pcs |
| P |  |               | Glue tube          | 1 pc   |

*The hardware quantities listed above are required for proper assembly.  
Some extra hardware may also have been included.*

# Step 1

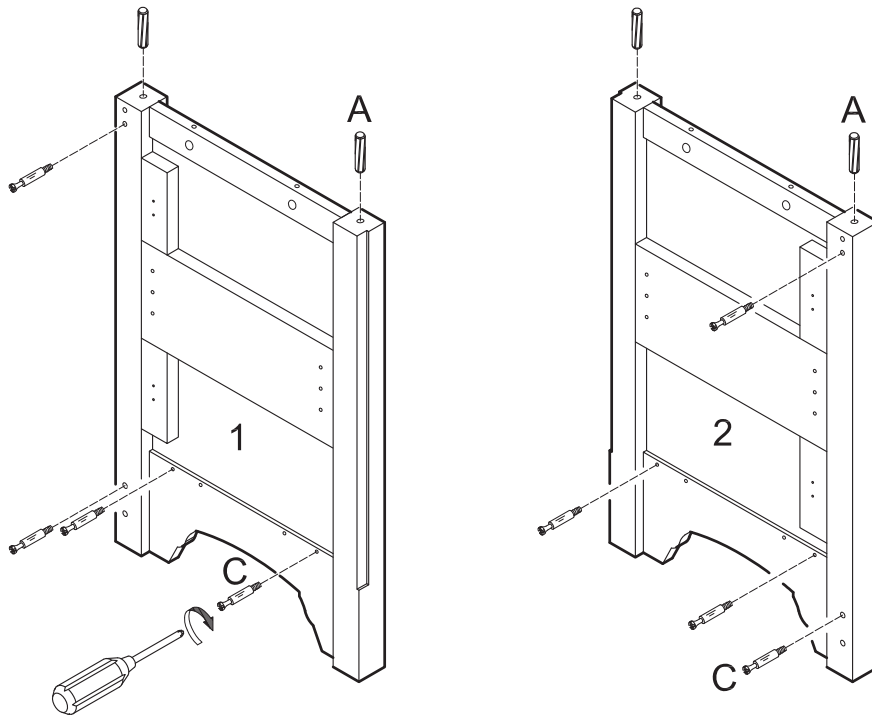

Insert large dowels (A) into side panels (1,2). Screw cam bolts (C) into side panels (1,2).

# Step 2

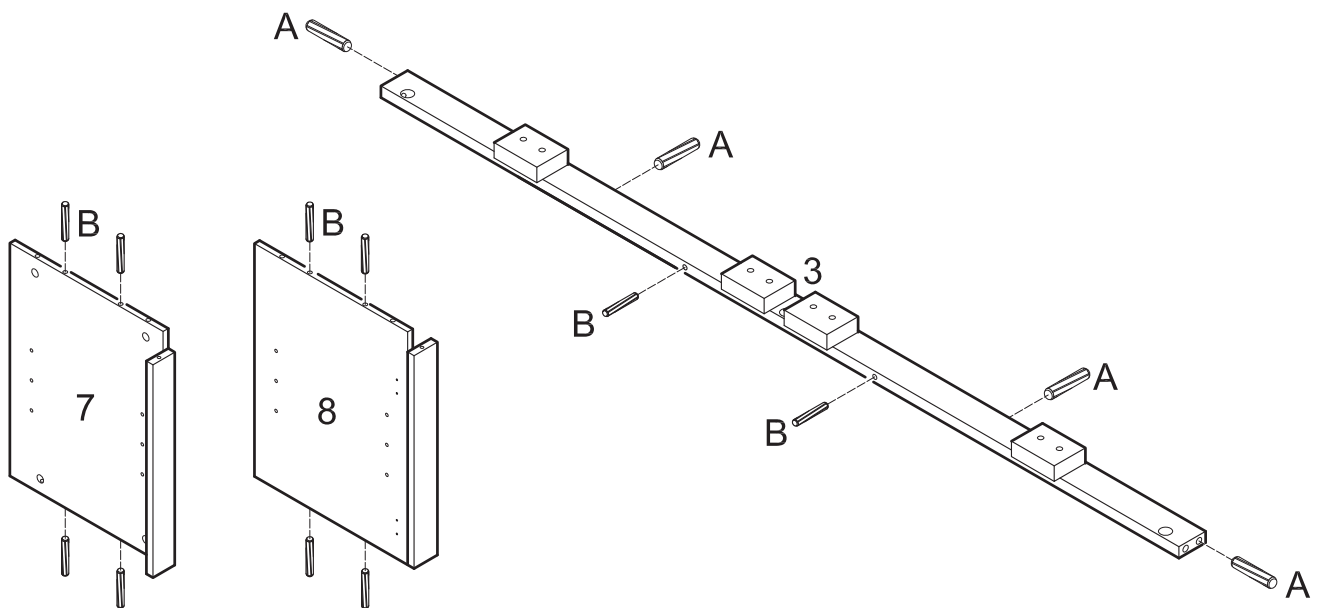

Insert small dowels (B) into panels (7,8) and slat (3). Insert large dowels (A) into slat (3).

## Step 3

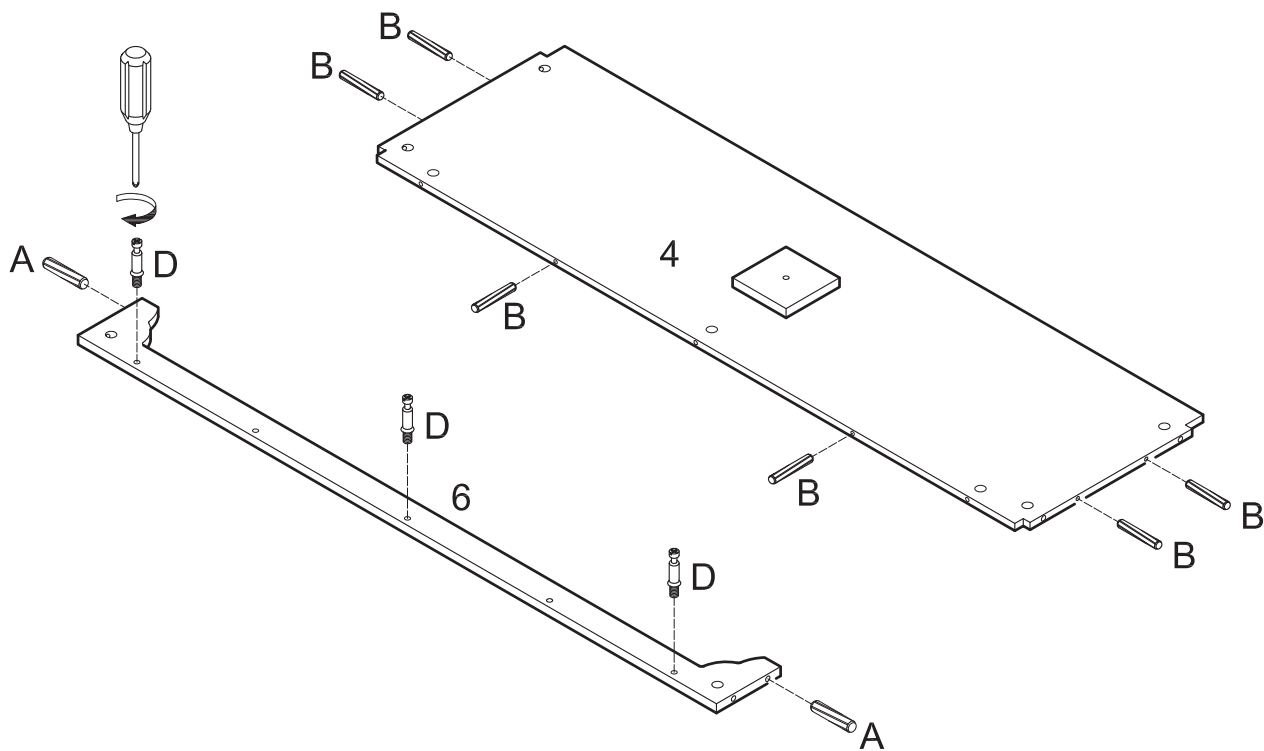

Insert large dowels (A) into slat (6). Insert small dowels (B) into bottom panel (4). Screw cam bolt (D) into slat (6).

## Step 4

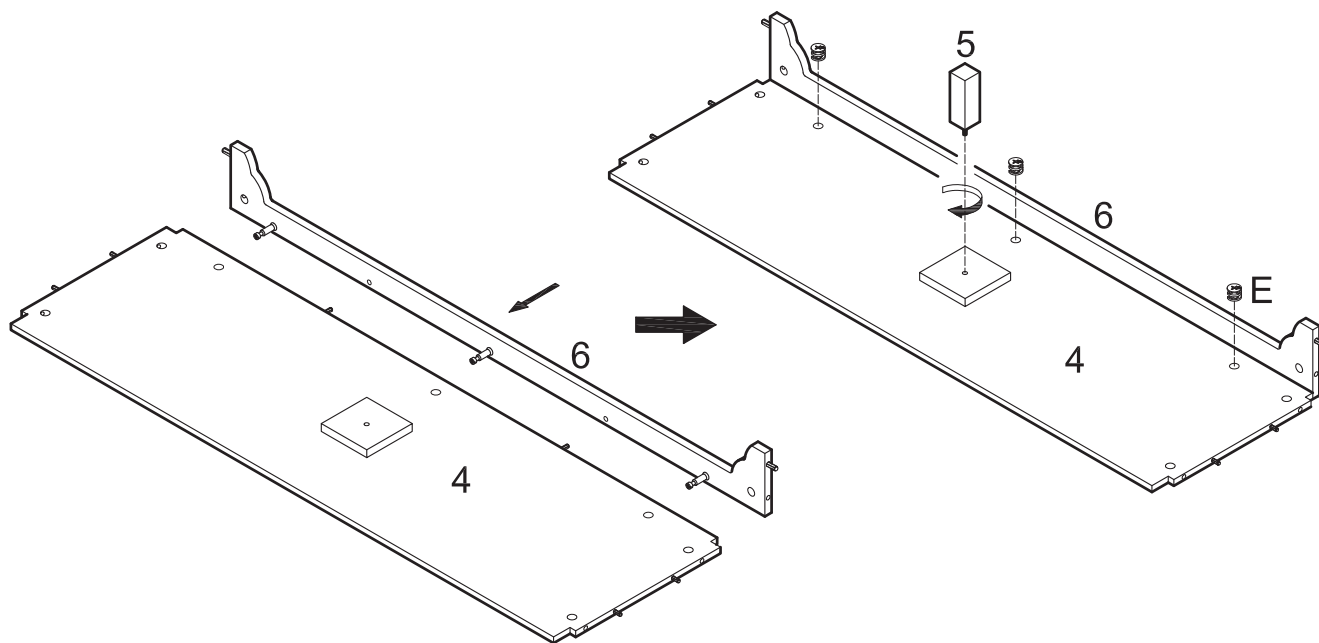
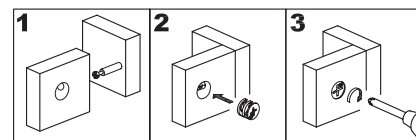

Attach slat (6) to bottom panel (4) using cam bolts and dowels as guides. Insert cam locks (E) into bottom panel (4) and tighten with a screwdriver. Screw leg (5) into bottom panel (4).

## Step 5

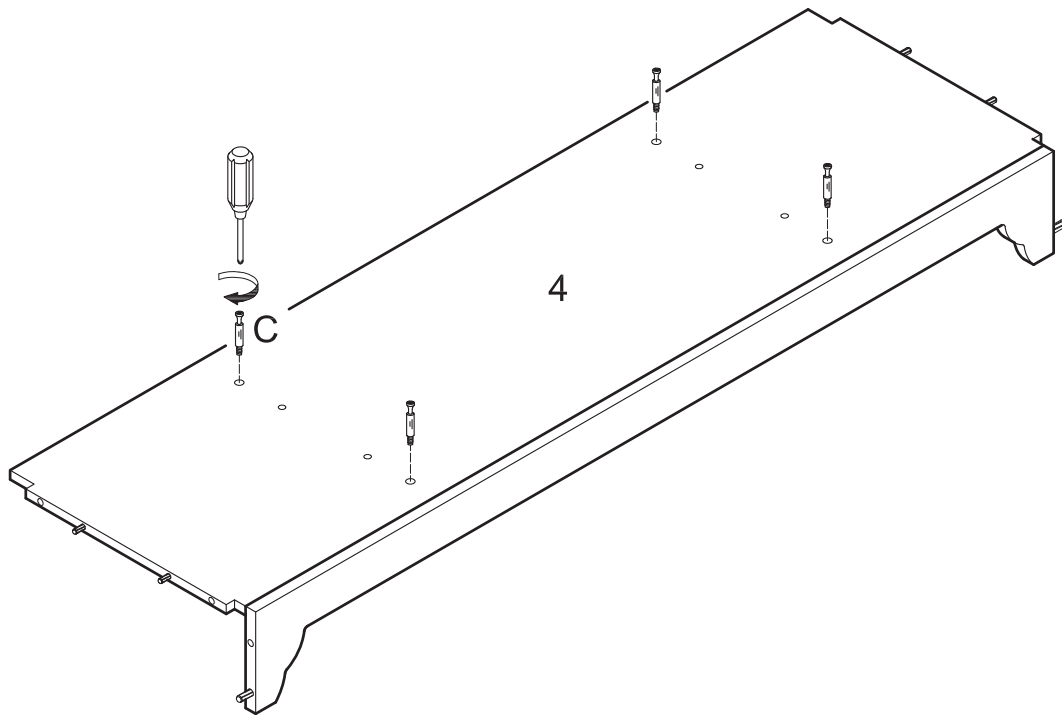

Screw cam bolts (C) into bottom panel (4).

## Step 6

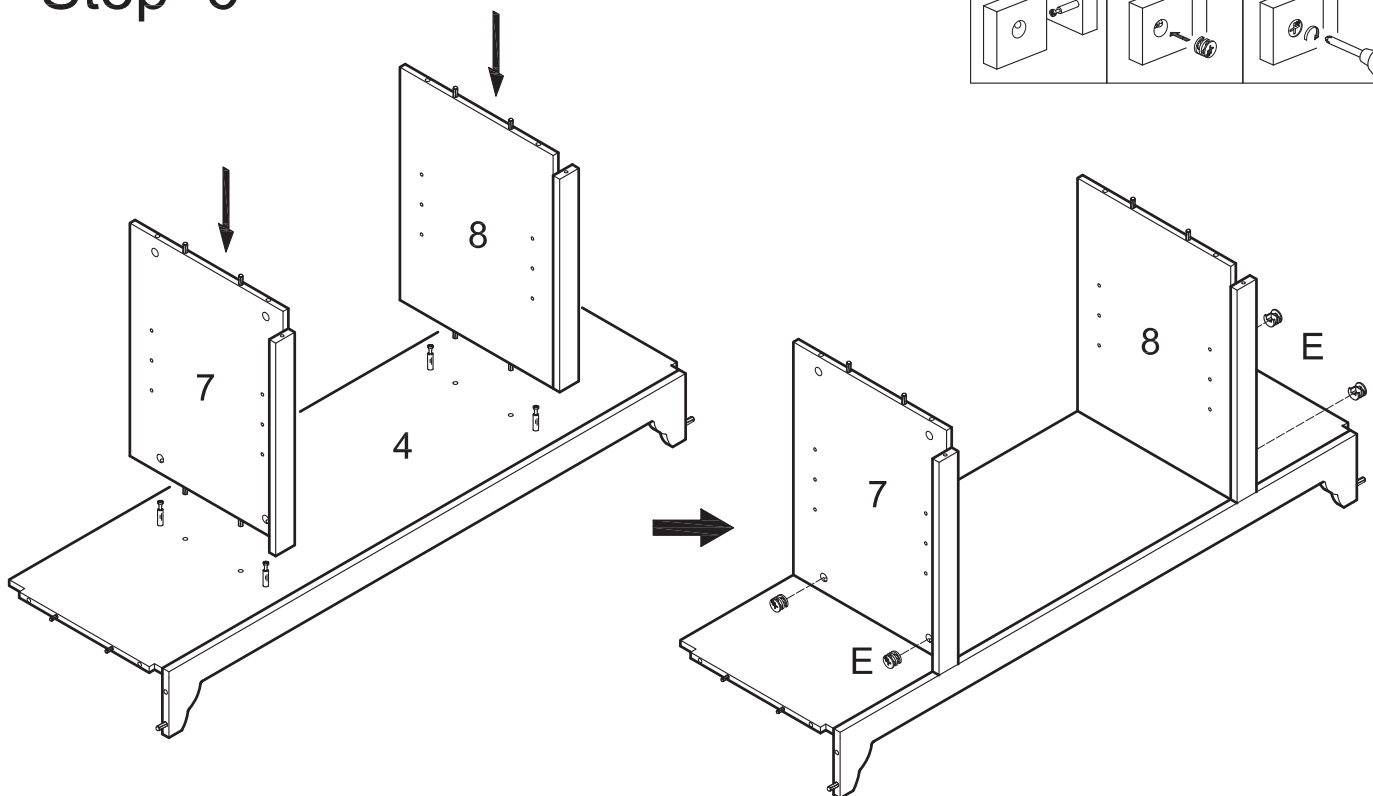
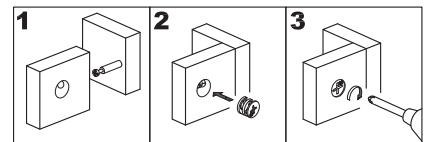

Attach panels (7,8) to bottom panel (4) using cam bolts and dowels as guides. Insert cam locks (E) into panels (7,8) and tighten with a screwdriver.

## Step 7

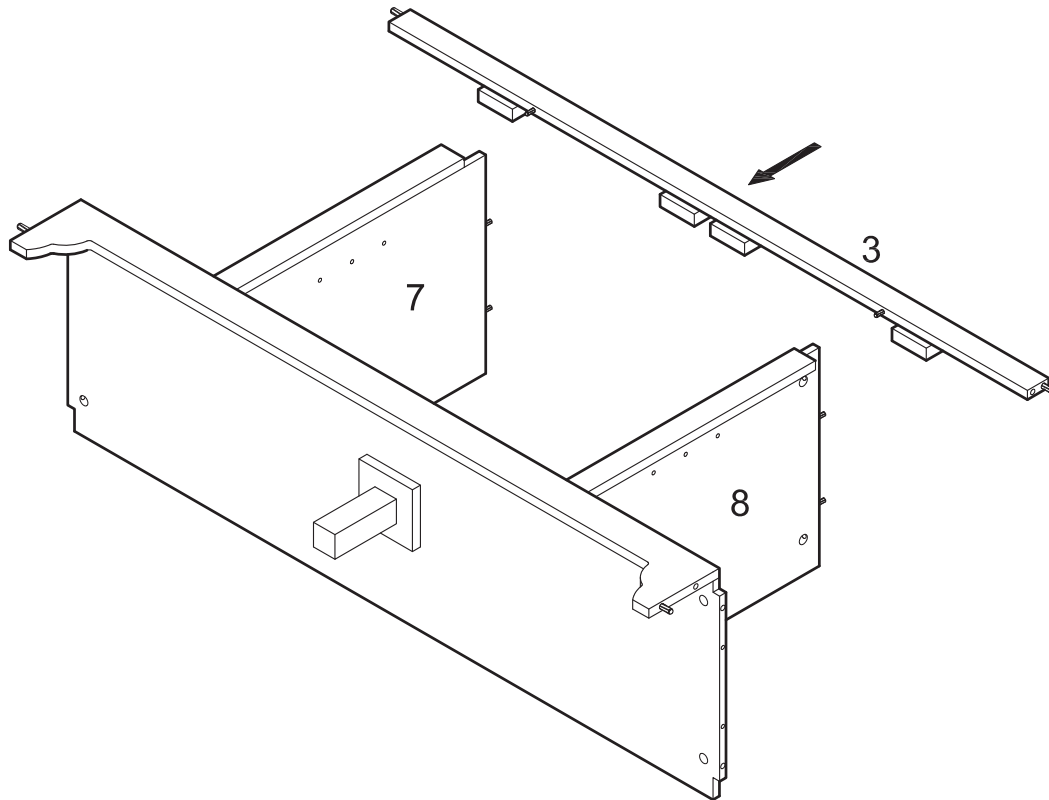

Attach slat (3) to panels (7,8) using dowels as guides.

## Step 8

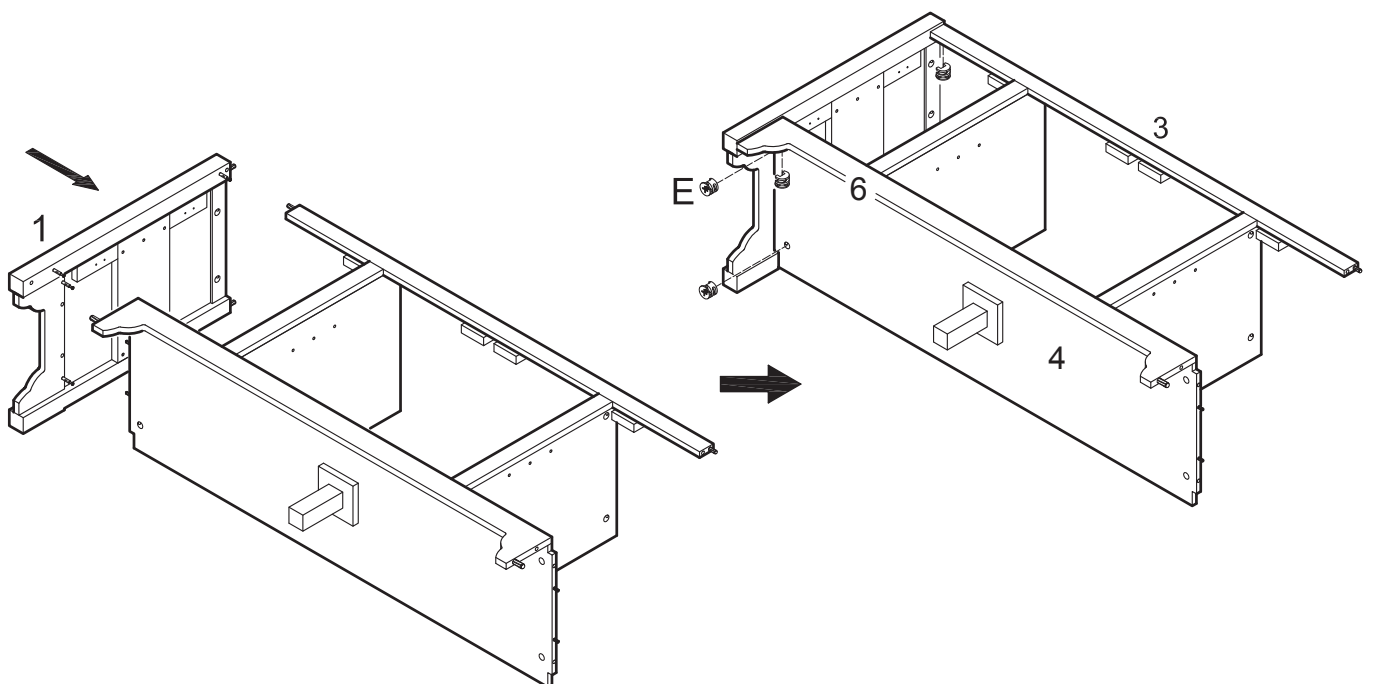
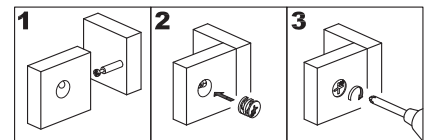

Attach side panel (1) to the assembly from the previous step using cam bolts and dowels as guides. Insert cam locks (E) into bottom panel (4) and slats (3,6). Tighten cam locks (E) with a screwdriver.

## Step 9

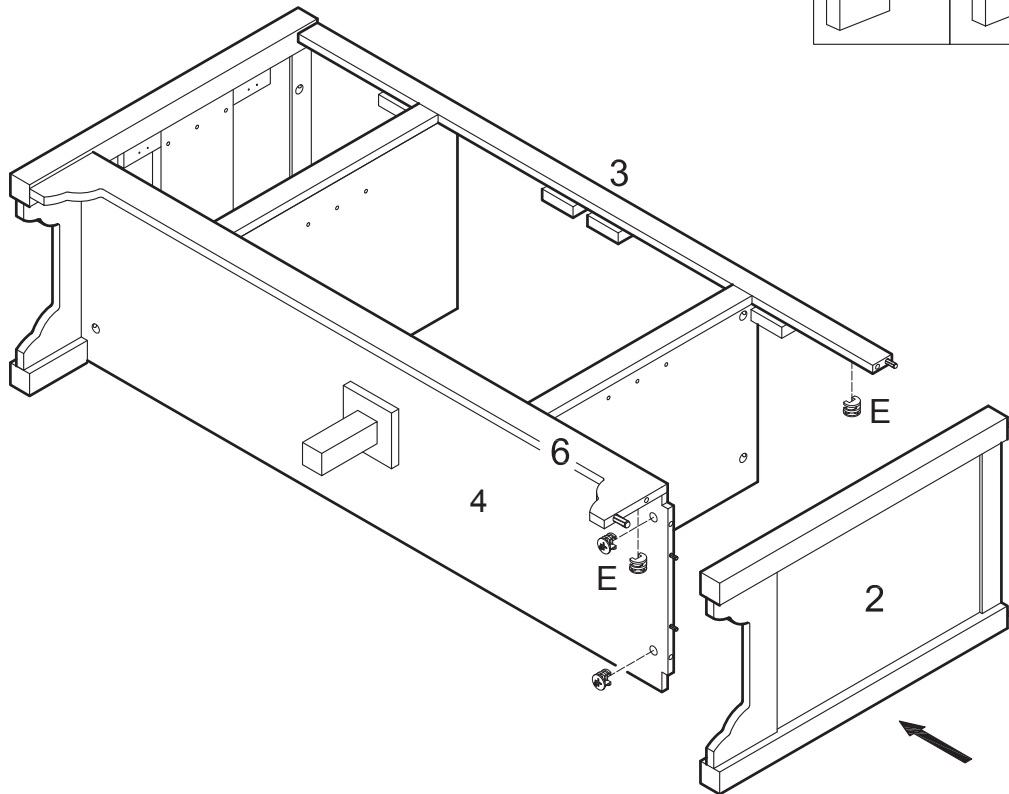
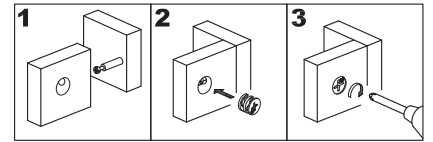

Attach side panel (2) to the opposite side of the assembly from Step 7 using cam bolts and dowels as guides. Insert cam locks (E) into bottom panel (4) and slats (3,6). Tighten cam locks (E) with a screwdriver.

## Step 10

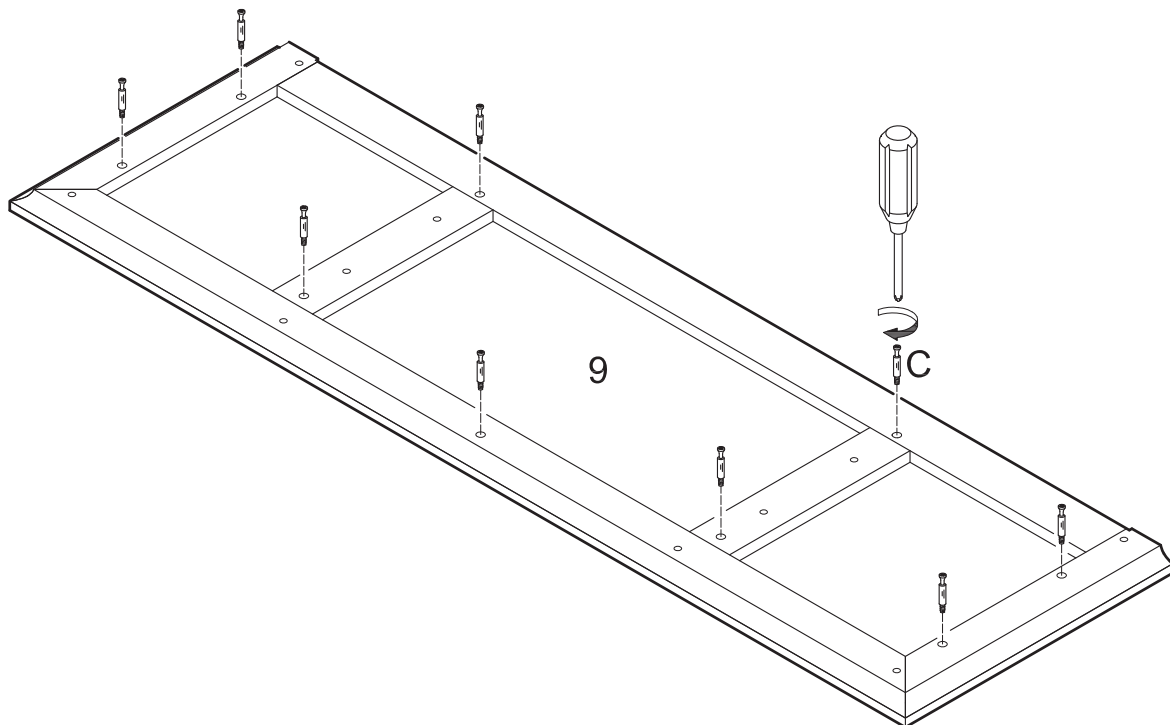

Screw cam bolts (C) into top panel (9).

## Step 11

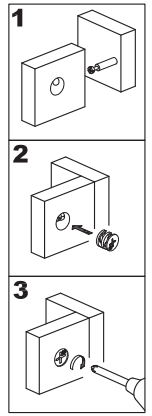
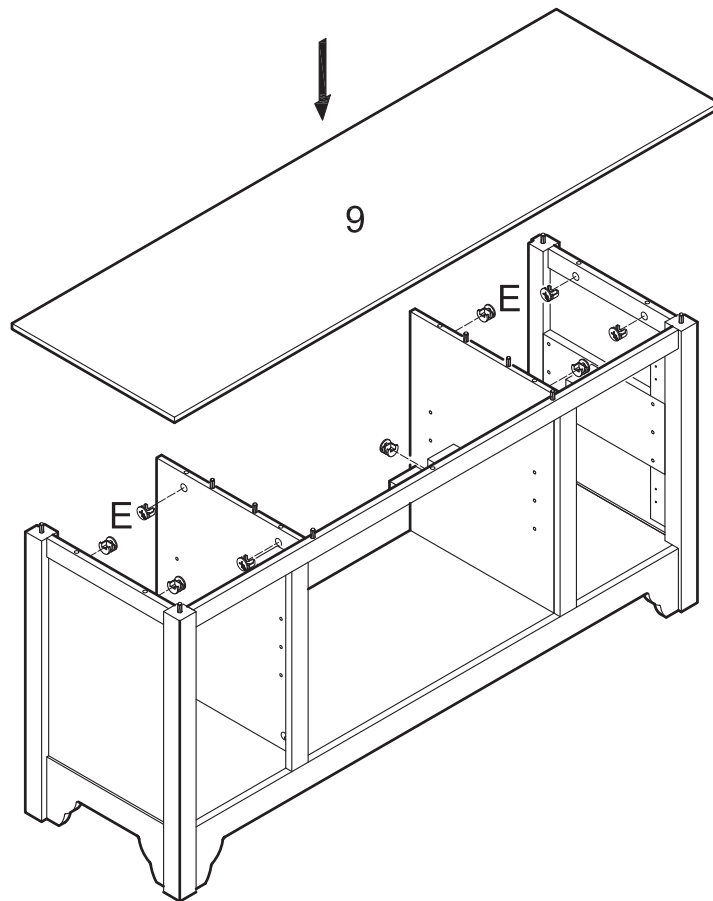

Insert cam locks (E) into the assembly from Step 9 as shown above. Attach top panel (9) to the assembly using cam bolts and dowels as guides. Tighten cam locks (E) with a screwdriver.

## Step 12

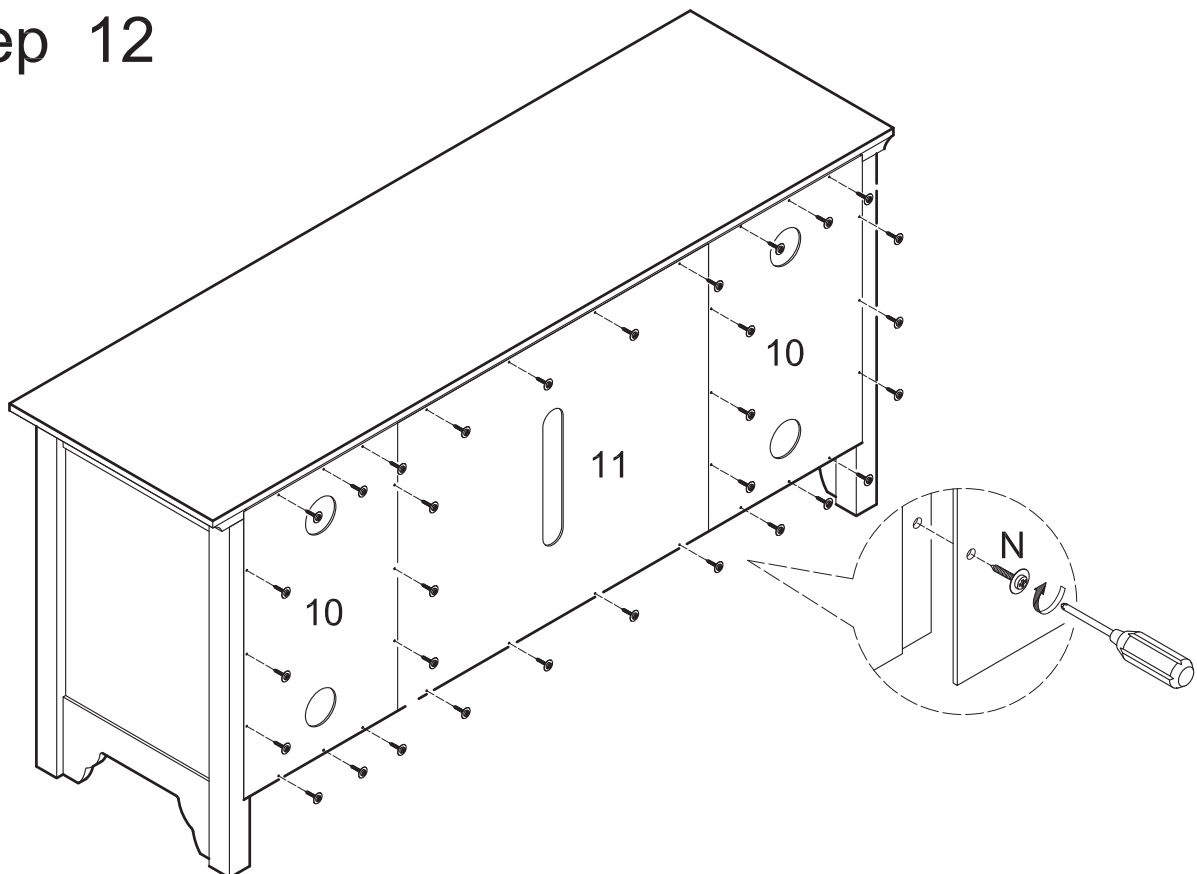

Attach back panels (10,11) to the assembly from the previous step using screws (N). *Note that back panels (10) will overlap back panel (11).*

## Step 13

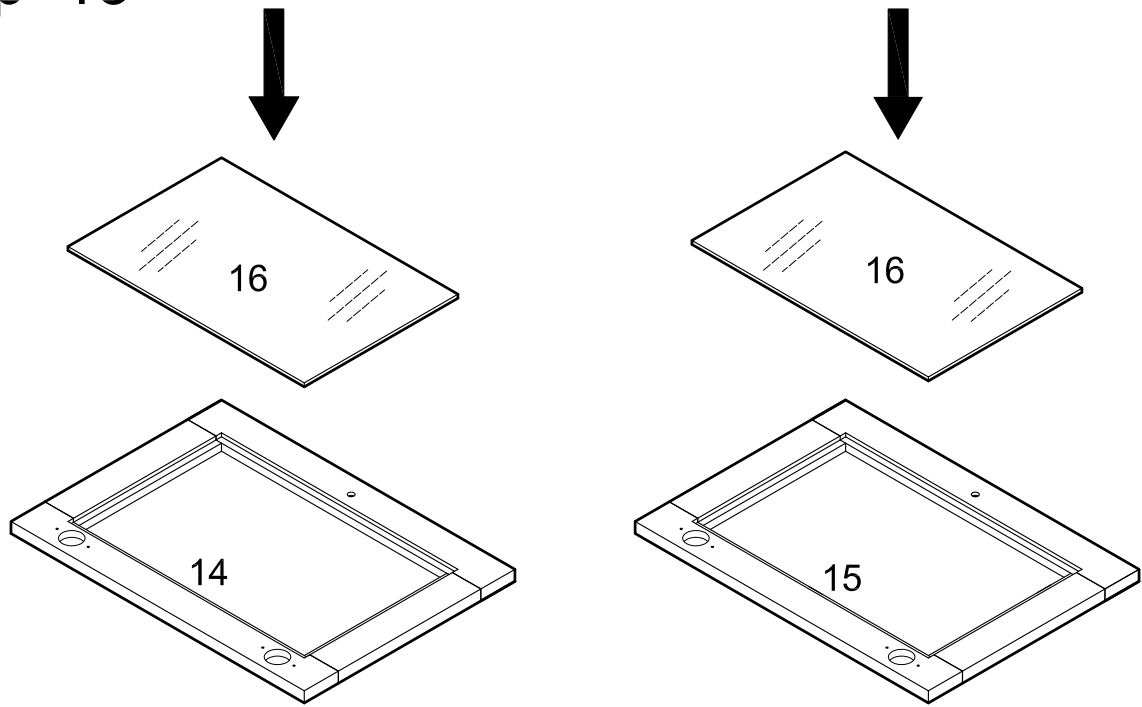

Carefully place glass panes (16) into door frames (14,15).

## Step 14

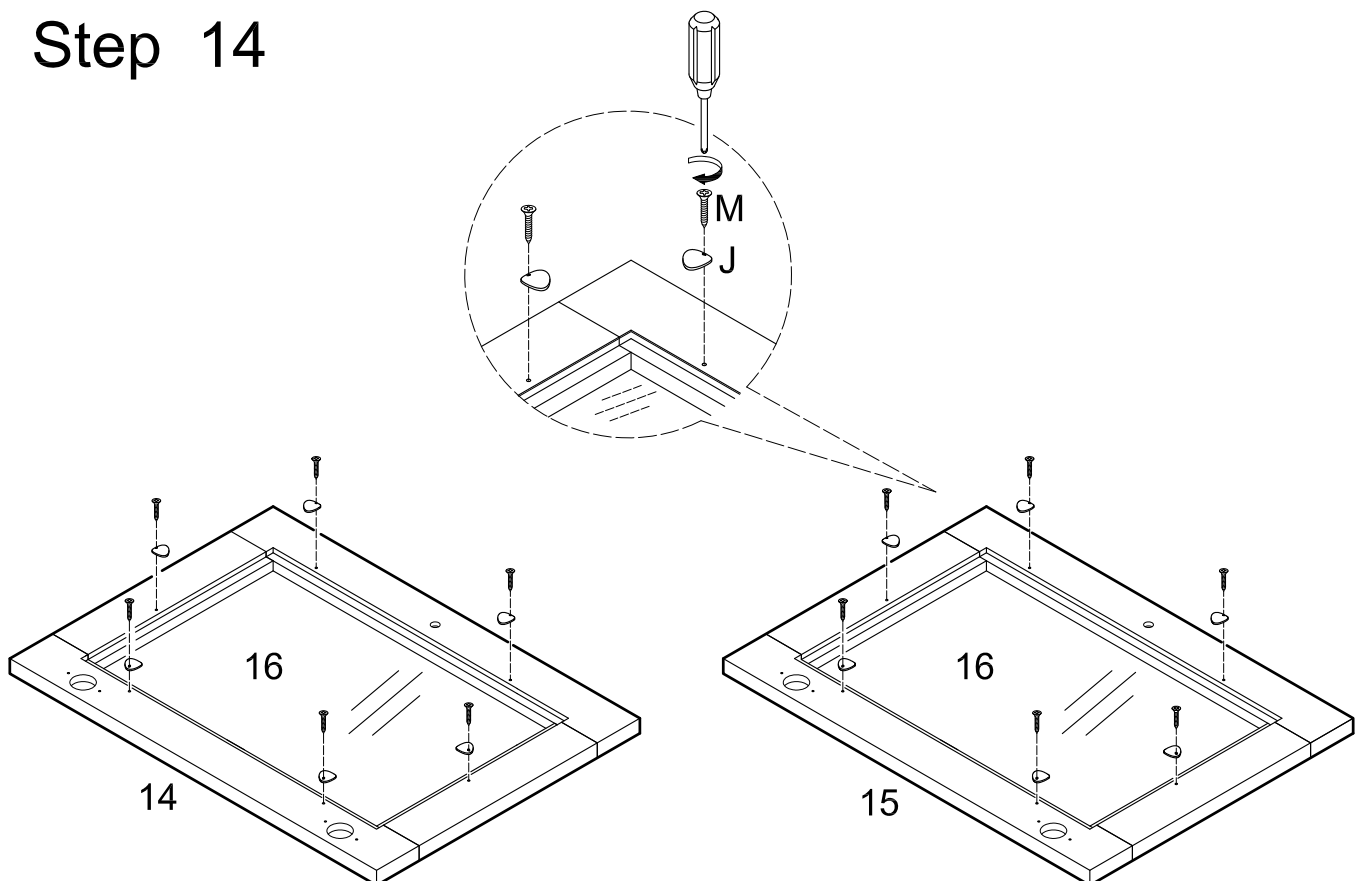

Secure glass panes (16) by attaching metal washers (J) to door frames (14,15) using screws (M). *The curve of metal washers (J) will arc into glass panes (16).*

## Step 15

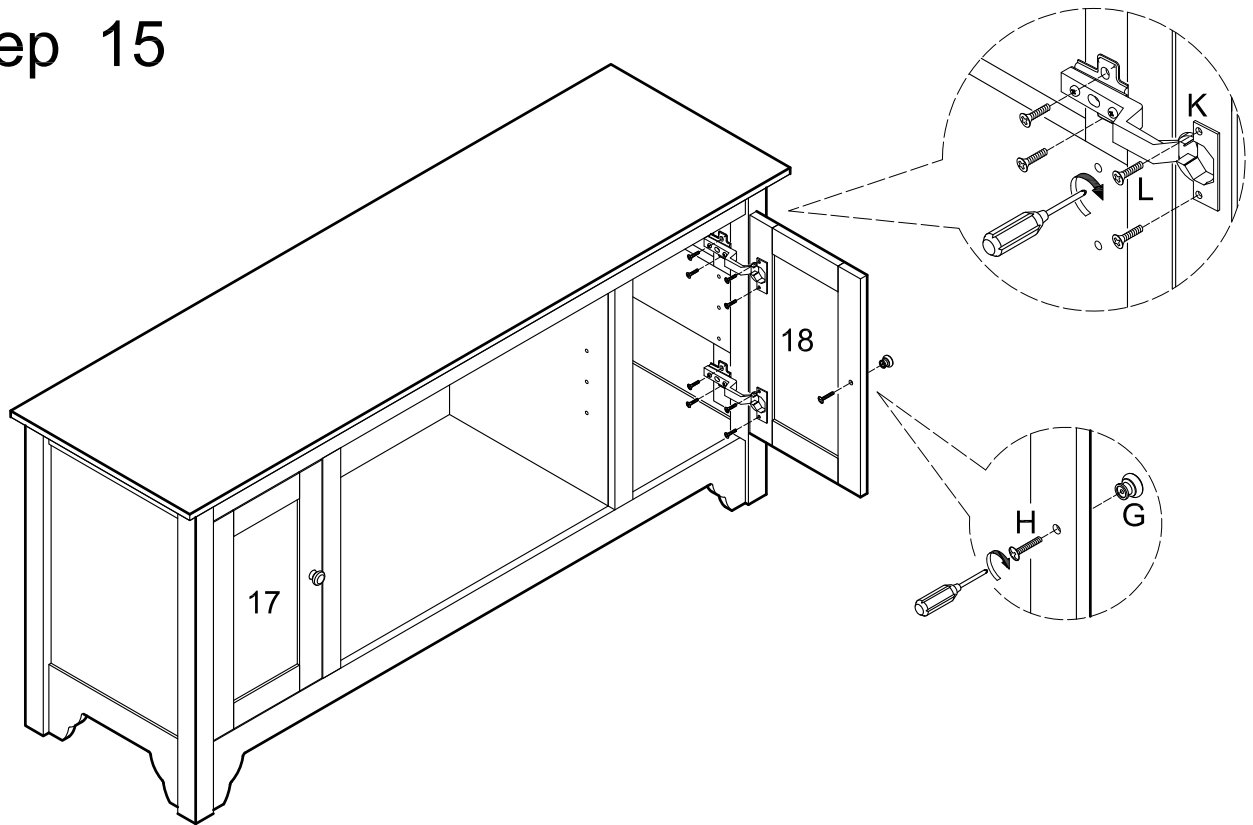

Attach doors (16,17) to the stand assembly using medium screws (M) at the hinges. Attach handles (G) to doors (16,17) using bolts (H).

## Step 16

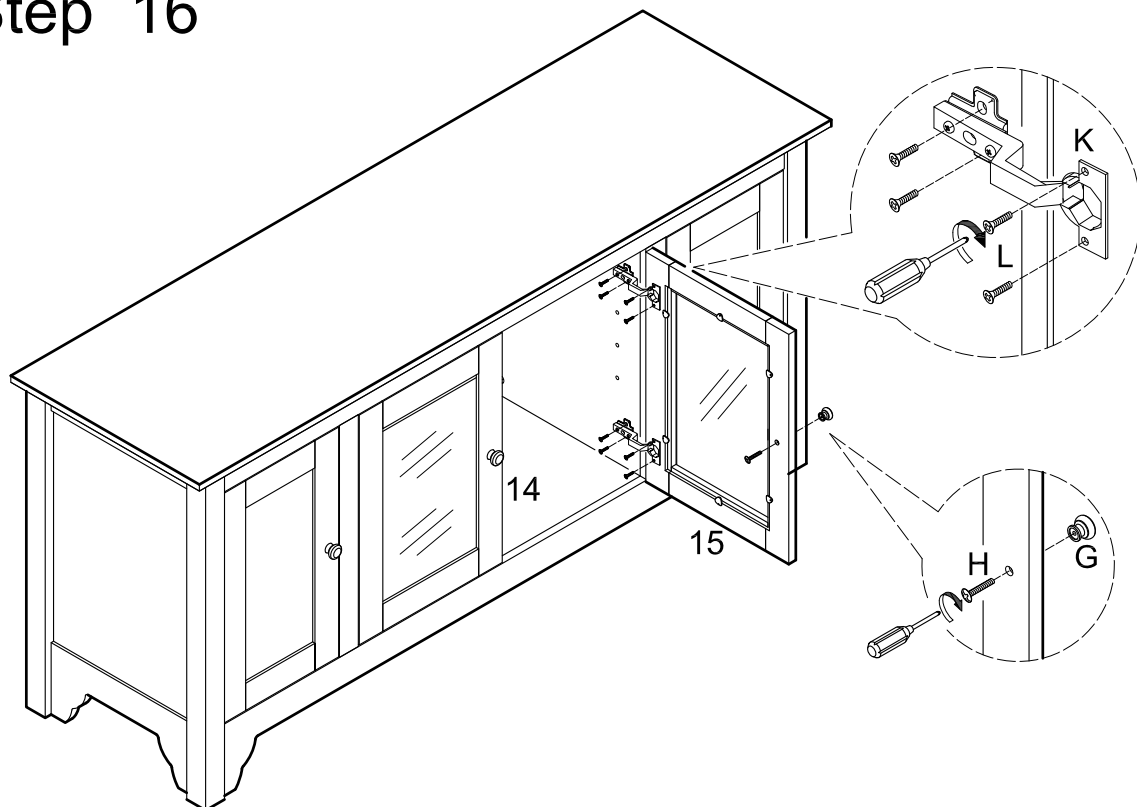

Attach doors (14,15) to the stand assembly using medium screws (M) at the hinges. Attach handles (G) to doors (14,15) using bolts (H).

## Step 17

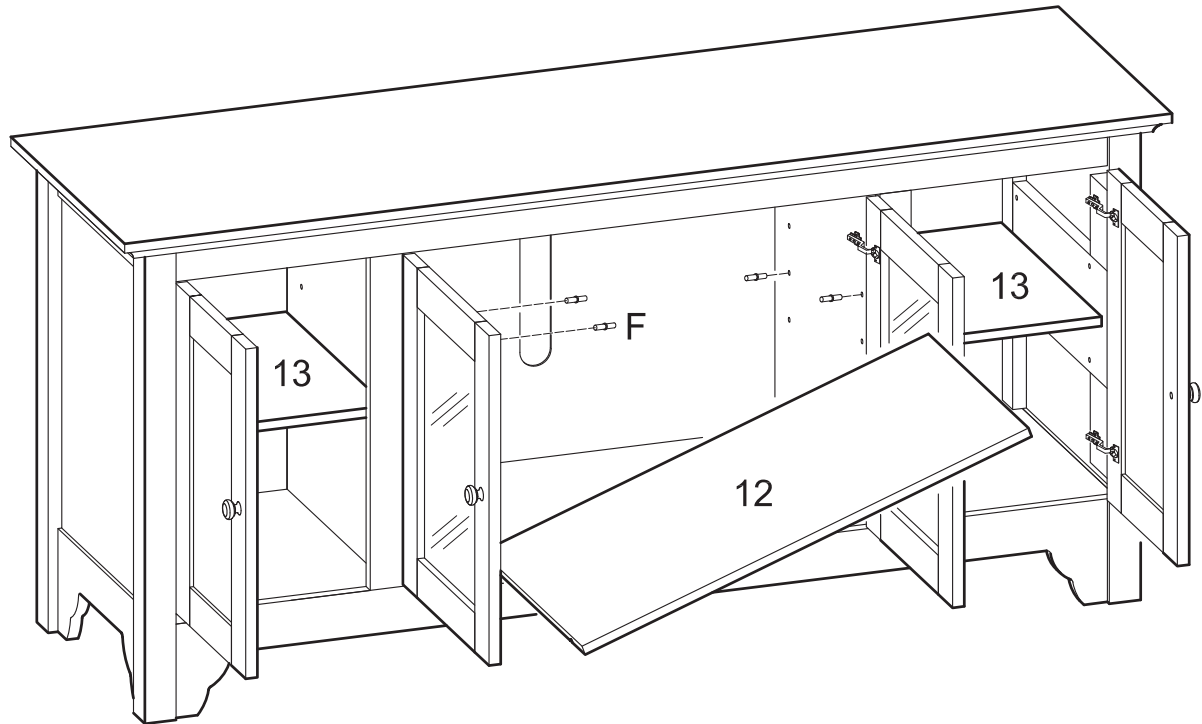

Insert shelf support pins (F) into the interior of the assembly at desired shelf heights. Carefully place shelves (12,13) on shelf support pins (F).

## Step 18

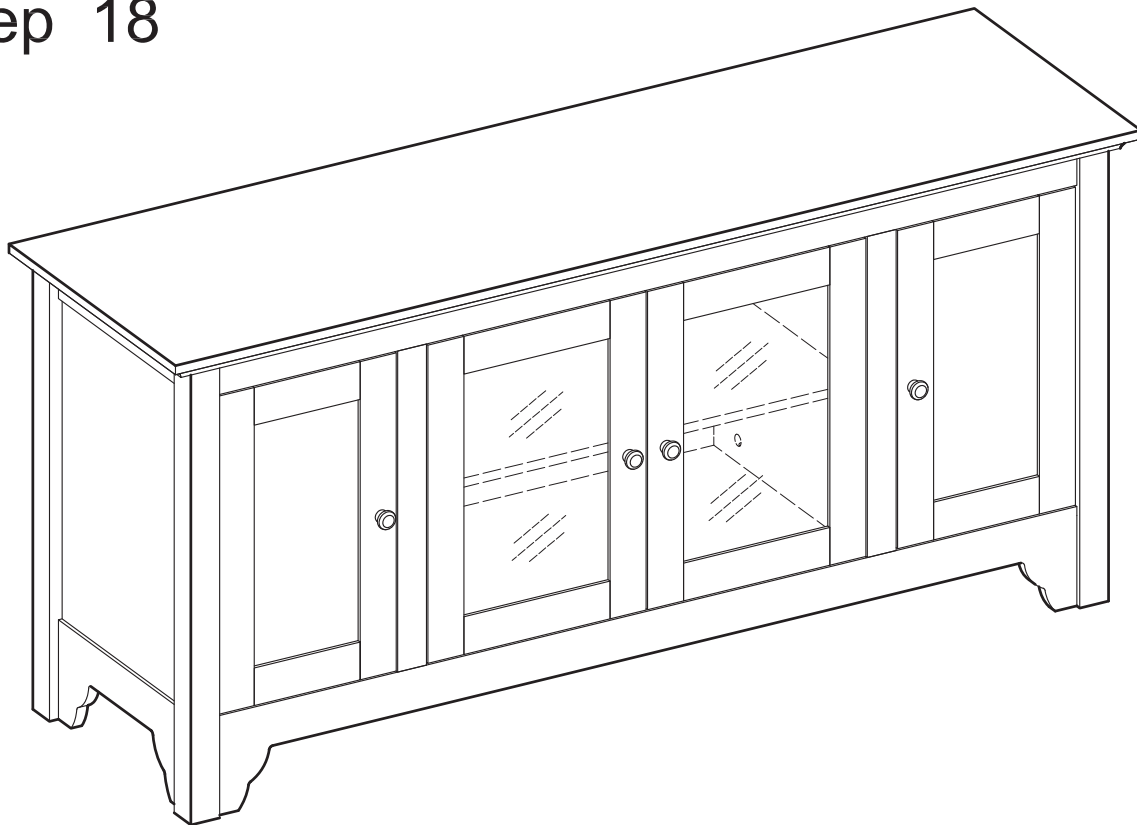

**Final Assembly**