

# Sectional Sofa Seating Group with Cushion

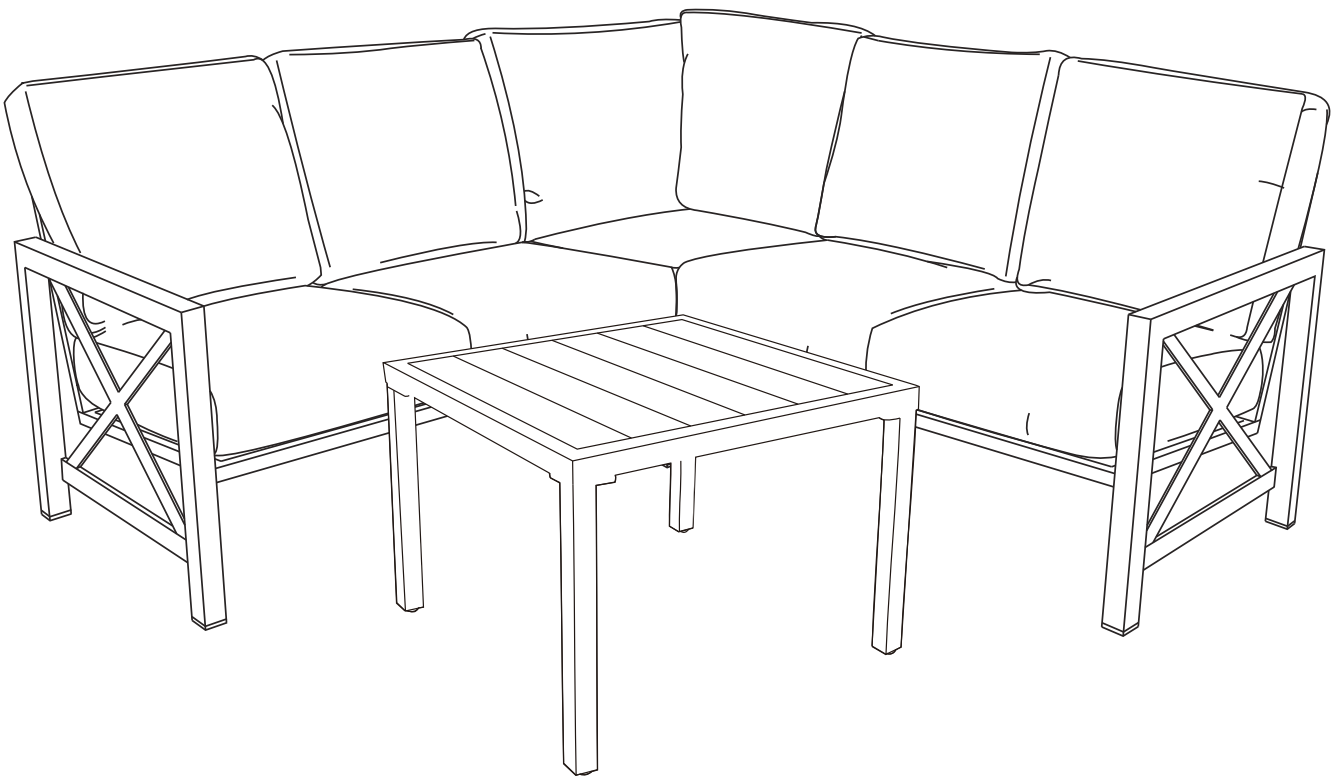









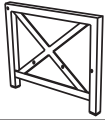

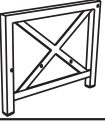
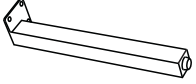
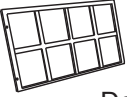

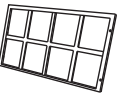









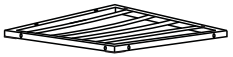



## Assembly Instructions



### WARNING

- 1. Please confirm all parts correct before assemble*
- 2. Do not tighten fastening fully until assembly is complete*
- 3. DO NOT USE POWER TOOLS. Power tools can overtighten screws and strip threads*

# PARTS LIST

CODE	PARTS	QTY.	CODE	PARTS	QTY.
A	 Leg-L	1PC	Q	 Single Leg(Short)	3PCS
B	 Leg-R	1PC	O	 Table Leg	4PCS
C	 Double Back-L	1PC	AA	 Bolt Cap(M6)	52PCS
D	 Double Back-R	1PC	BB	 M6*20	18PCS
E	 Double Seat-L	1PC	CC	 M6*30	6PCS
F	 Double Seat-R	1PC	DD	 M6*45	10PCS
G	 Single Back-L	1PC	EE	 M6*55	2PCS
H	 Single Back-R	1PC	FF	 Washer Φ6*12	48PCS
I	 Single Seat	1PC	GG	 Nut (M6)	4PCS
J	 Double Seat Cushion	4PCS	HH	 Nut Cap(M6)	4PCS
K	 Double Back Cushion	4PCS	II	 Hex Wrench	1PC
L	 Single Seat Cushion	1PC	JJ	 Spanner	1PC
M	 Single Back Cushion	1PC	KK	 M6*40	4PCS
N	 Table Rim	1PC	LL	 Φ6*14	8PCS
P	 Single Leg(Long)	1PC	MM	 M6*15	12PCS

1

**ATTENTION: Not tighten down all the screws until working on final assembly**

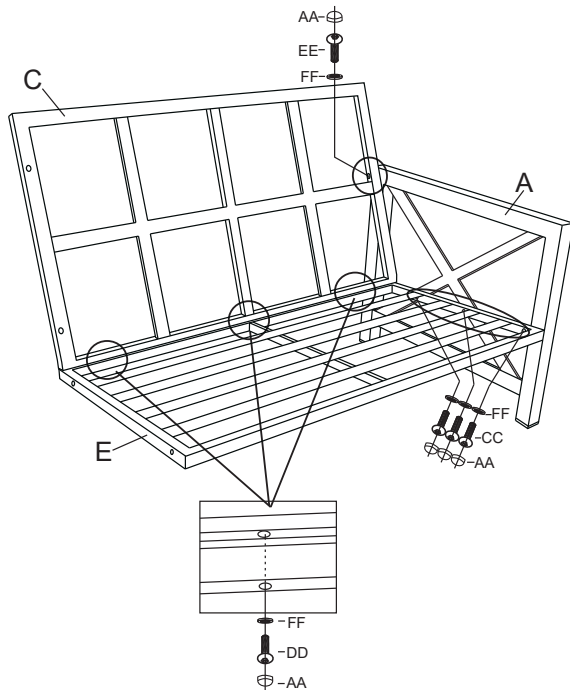

- Attached Double Seat-L (E) to the Double back-L (C) with washer (FF) and bolts (DD) using hex wrench
- Attach Leg-L (A) to the Double Seat-L (E) with washers (FF) and bolts (CC), then attach Leg-L (A) to the Double back-L (C) with washer (FF) and bolts (EE) using hex wrench.

2

**ATTENTION: Not tighten down all the screws until working on final assembly**

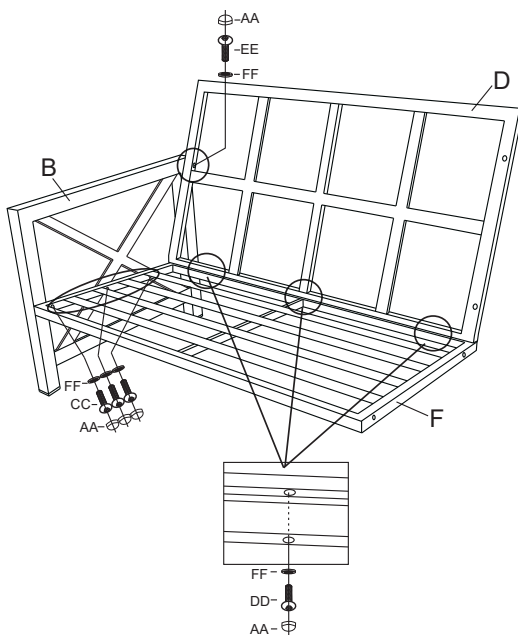

- Attached Double Seat-R (F) to the Double Back-R (D) with washers (FF) and bolts (DD) using hex wrench
- Attach Leg-R (B) to the Double Seat-R (F) with washers (FF) and bolts (CC), then attach Leg-R (B) to the Double Back-R (D) with washers (FF) and bolts (EE) using hex wrench.
- Tighten bolts using hex wrench and put bolt cap (AA) to **all bolts**.

3

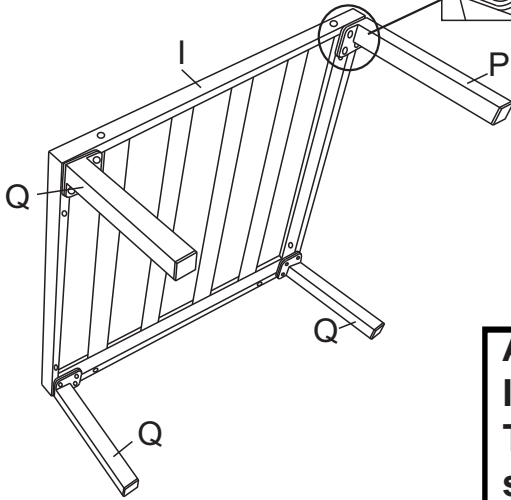
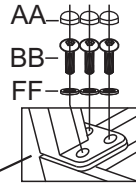

- Attach Single Long Leg(P) and Single Short Leg(Q) to Single Seat(I).
- There are P/Q stickers around all holes, put on legs to accordingly holes with washers(FF) and bolts(BB), using hex wrench.
- Tighten bolts once all bolts in place.
- Cover all bolts with bolts caps(AA).

**Attention:**  
**It's Not Damaged!!!**  
**To provide comfortable seat, the Single seat(I) is curved!!!**  
 It will connect left&right double seat as a corner.

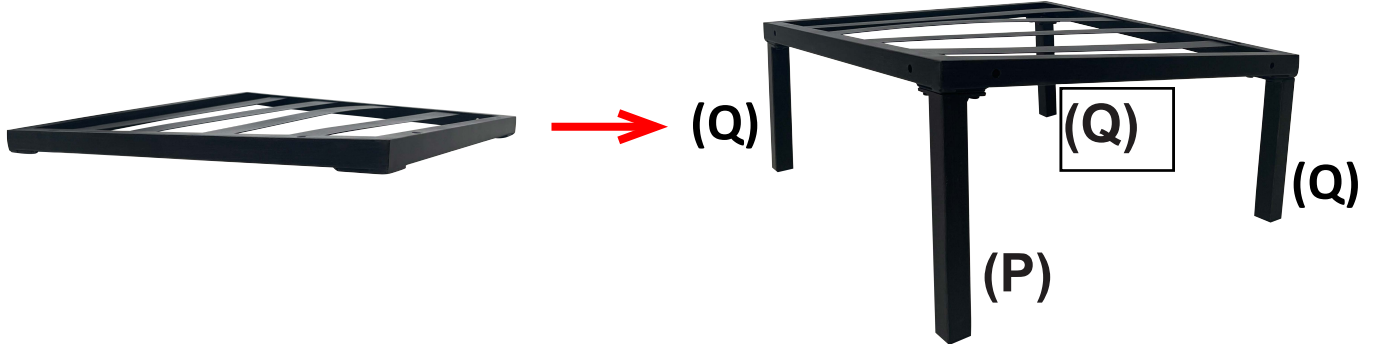

4

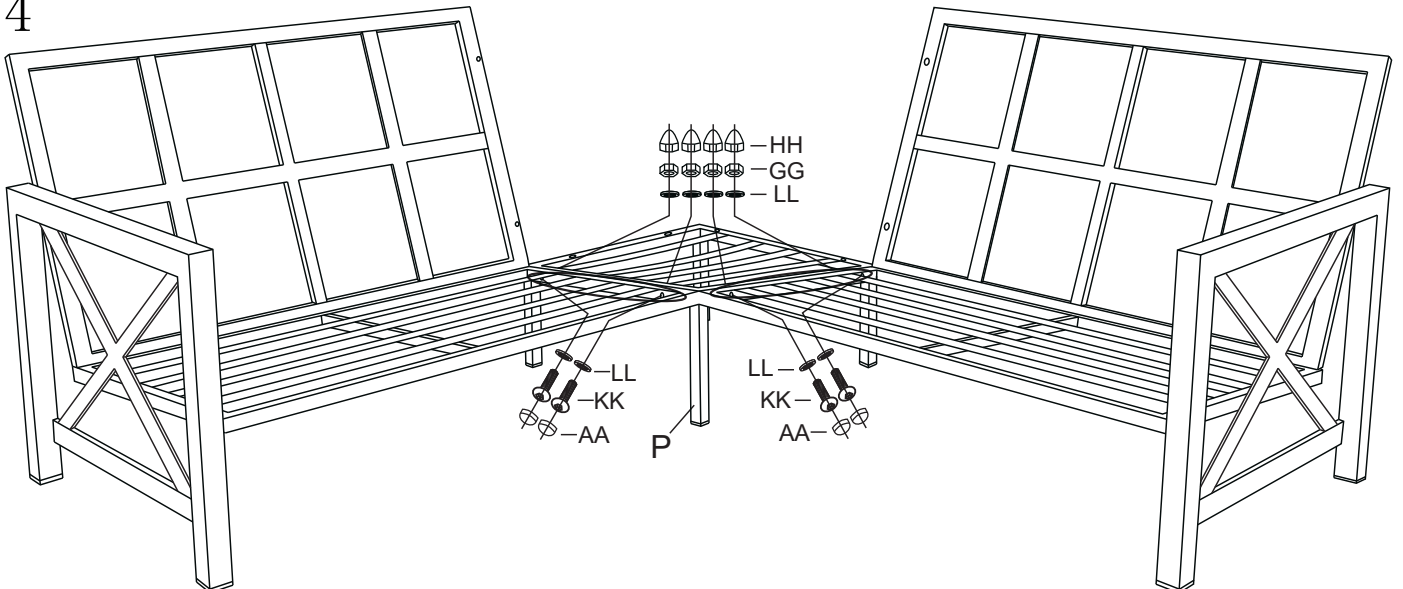

- Attach Left and Right Loveseats to the Corner Seat with washers(LL) and bolts(KK) and nuts (GG)at the seat section.
- Tighten bolts using hex wrench and put bolt cap(AA) and nut cap(HH) to bolts.

5

**ATTENTION: Not tighten down all the screws until working on final assembly**

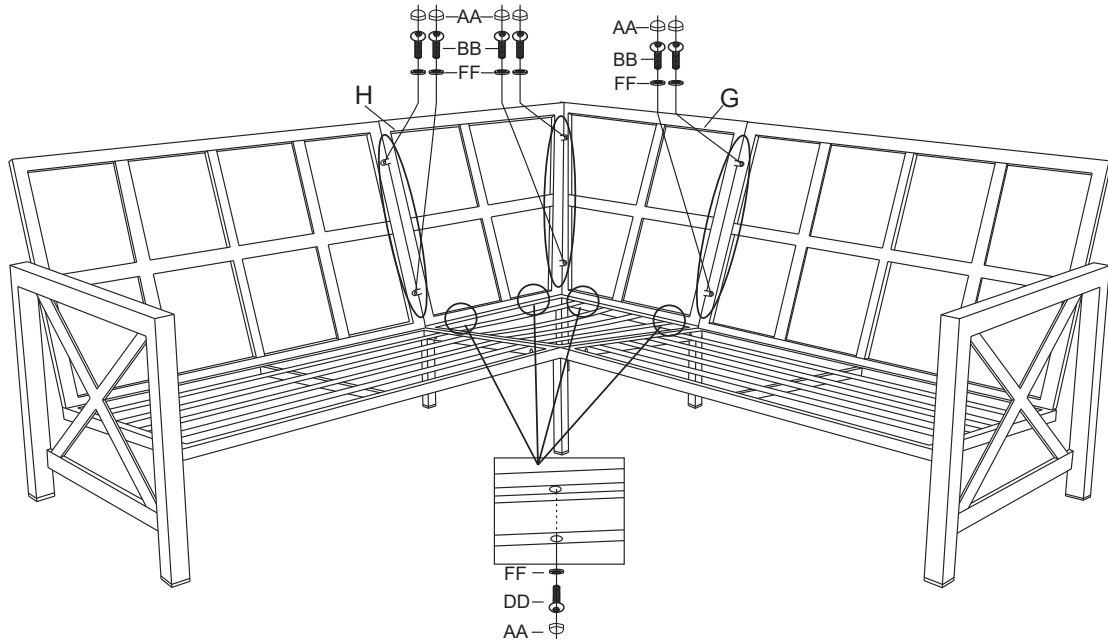

- Attach Single Back-L (G) and Single Back-R(H) to the Corner Seat (I) with washers(FF) and bolts(BB), then assemble to loveseats with washers(FF) and bolts(DD).
- Tighten bolts using hex wrench and put bolt cap(AA) to all bolts.



6

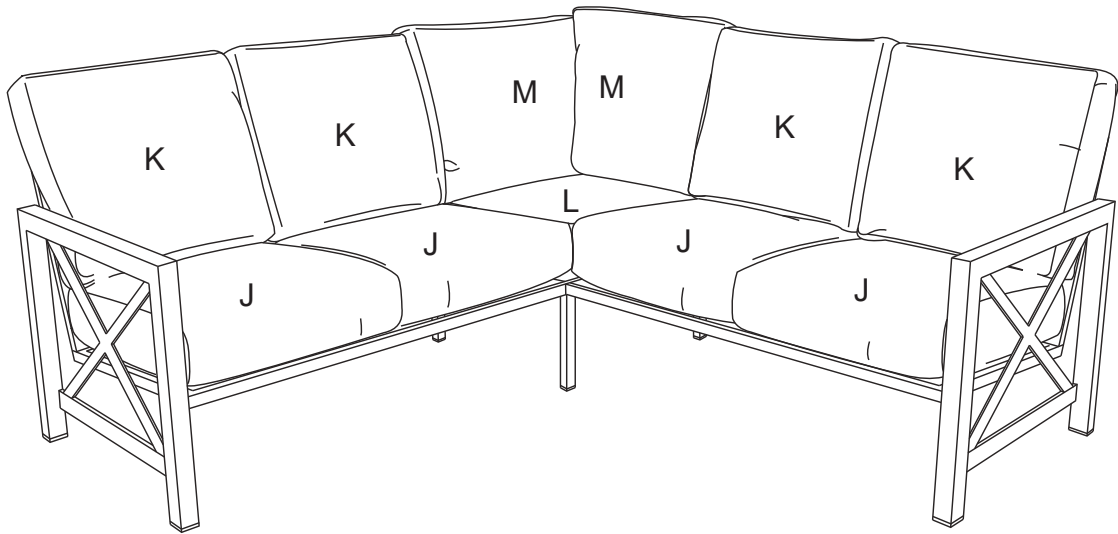

- Place cushions on the chair.
- Cover all bolts with bolts caps
- Level the chair with adjustable feet cap if necessary

7

Step 2

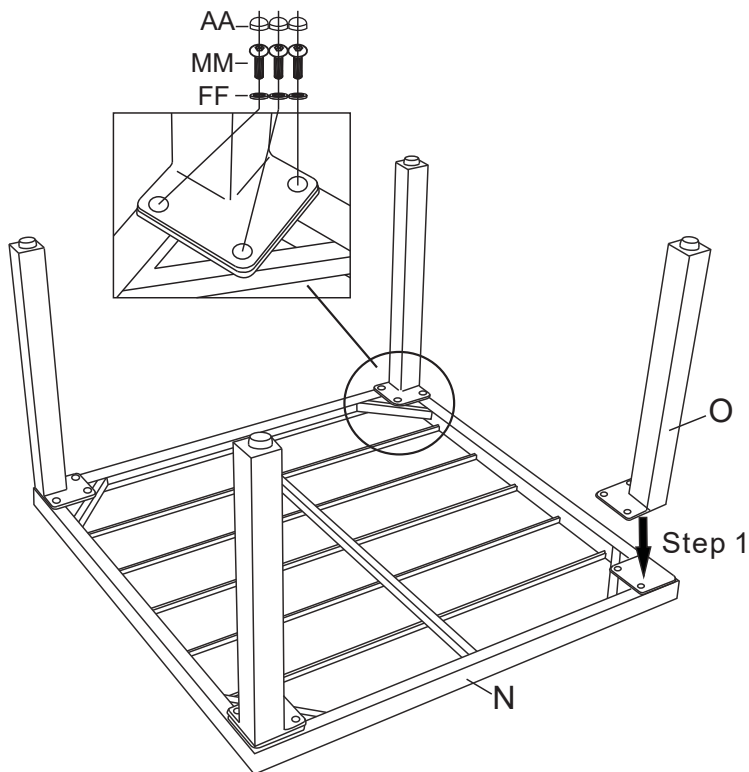

- Align Table Leg (O) to the Table Rim (N) with washers(FF) and bolts(MM), using hex wrench.
- Tighten bolts once all bolts in place.
- Cover all bolts with bolts caps.

8

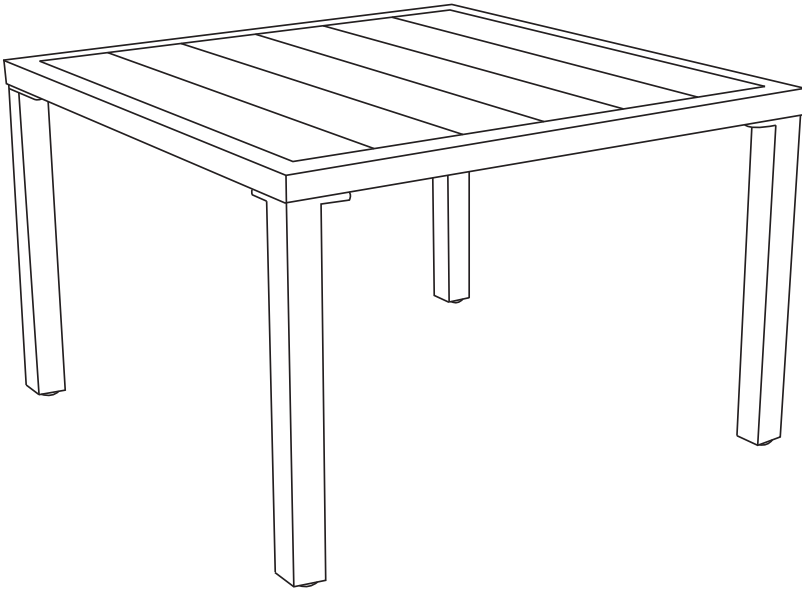

- Turn the table upright.
- If necessary level the table with adjustable feet cap at the bottom of each table leg.

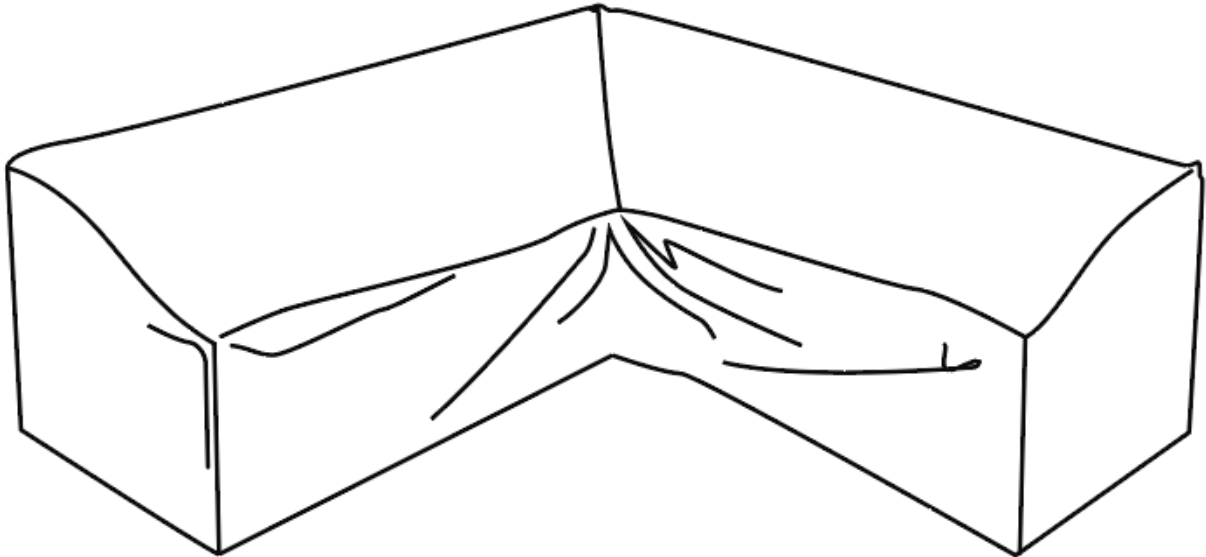

The cover is made by oxford fabric with an added UV-stabilized & Water-proof coating , and a waterproof laminated backing could prevent water from seeping through cover and keeps your conversation set dry and ready to use.