

ASSEMBLY INSTRUCTIONS

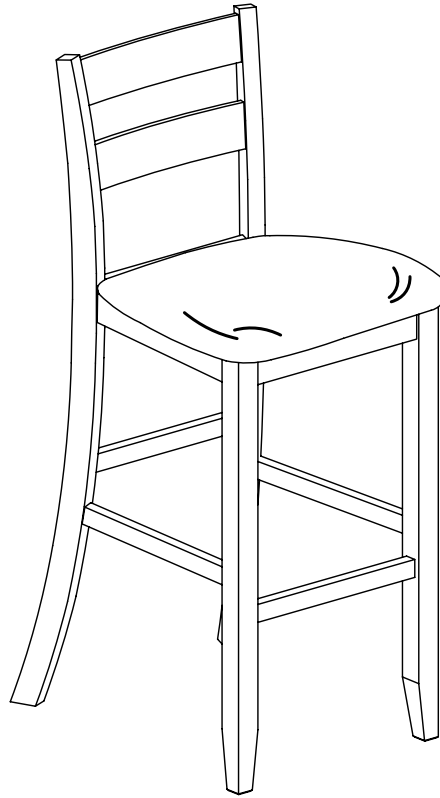





BAR STOOL

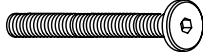

HARDWARE PACKAGE COUNT

OPEN HARDWARE PACKAGE ON A FLAT SURFACE COVERED WITH NEWSPAPER. COUNT EACH PIECE OF HARDWARE TO MATCH THE QUANTITY NUMBER IN THE HARDWARE LIST COLUMN. CALL CUSTOMER SERVICE IF ANY OF THE PARTS ARE MISSING. FOLLOW THE LETTER IDENTIFICATION WHEN READING THE ASSEMBLY DRAWING "A" THROUGH "G"

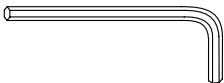
HARDWARE IDENTIFICATION

CODE	HARDWARE	DESCRIPTION	QTY
A	 $\text{Ø}\frac{1}{4}" \times 3\text{-}1/2"$	BOLT	4
B	 $\text{Ø}\frac{1}{4}" \times 2\text{-}1/2"$	BOLT	4
C	 $\text{Ø}\frac{1}{4}" \times 1\text{-}3/4"$	BOLT	2
D		FLAT WASHER	10
E		SPRING WASHER	10
F		ALLEN WRENCH	1
G	 $\text{Ø}4 \times 40\text{mm}$	SCREW	6

ALL PARTS ARE LABELED WITH STICKERS MATCHING THE PART IDENTIFICATION NUMBERS LISTED IN LEFT COLUMN.

IMPORTANT

PLEASE USE ALL THE HARDWARE MENTIONED ABOVE .
THEY WILL ASSURE THE ITEM STABILITY AND SAFETY.

TOOLS REQUIRED

A STANDARD PHILLIPS HEAD SCREWDRIVER (NOT PROVIDED) AND AN ALLEN WRENCH "F" (PROVIDED) ARE REQUIRED TO ASSEMBLE THIS UNIT. USE A PLASTIC HERD MALLET, NOT PROVIDED, TO TAP IN STRETCHERS OR OTHER COMPONENTS.

PART IDENTIFICATION:

CODE	DESCRIPTION	QTY
1	CHAIR BACK	1
2	SEAT FRAME	1
3	FRONT RIGHT LEG	1
4	FRONT LEFT LEG	1
5	FRONT CROSSBAR	1
6	LEFT CROSSBAR	1
7	RIGHT CROSSBAR	1

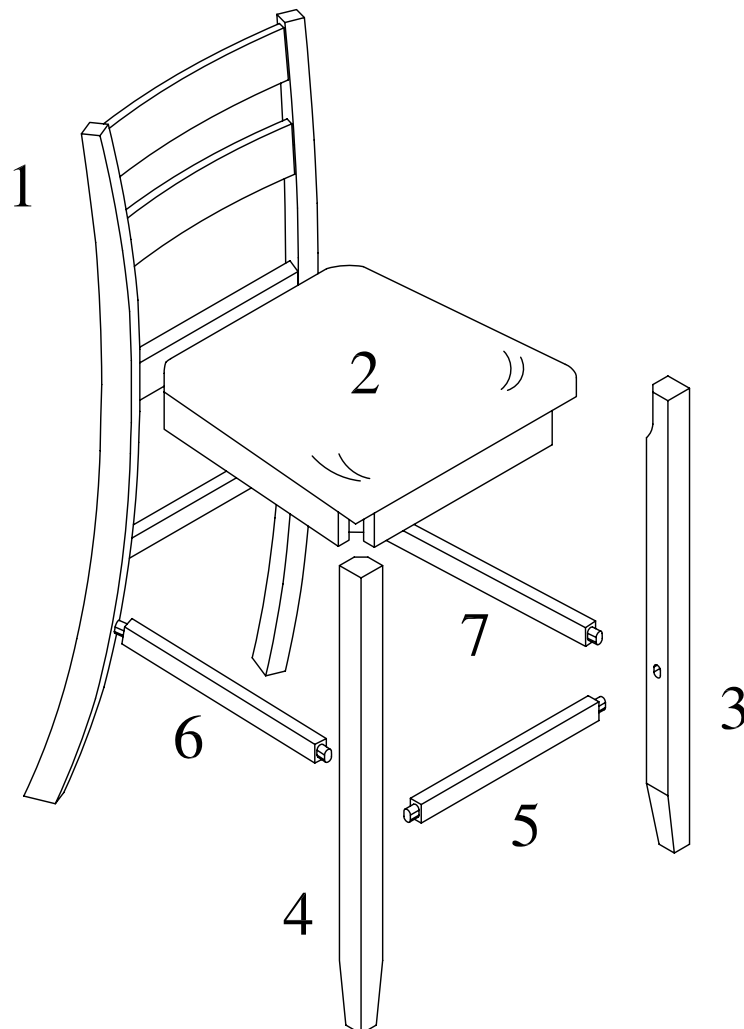

STEP 1

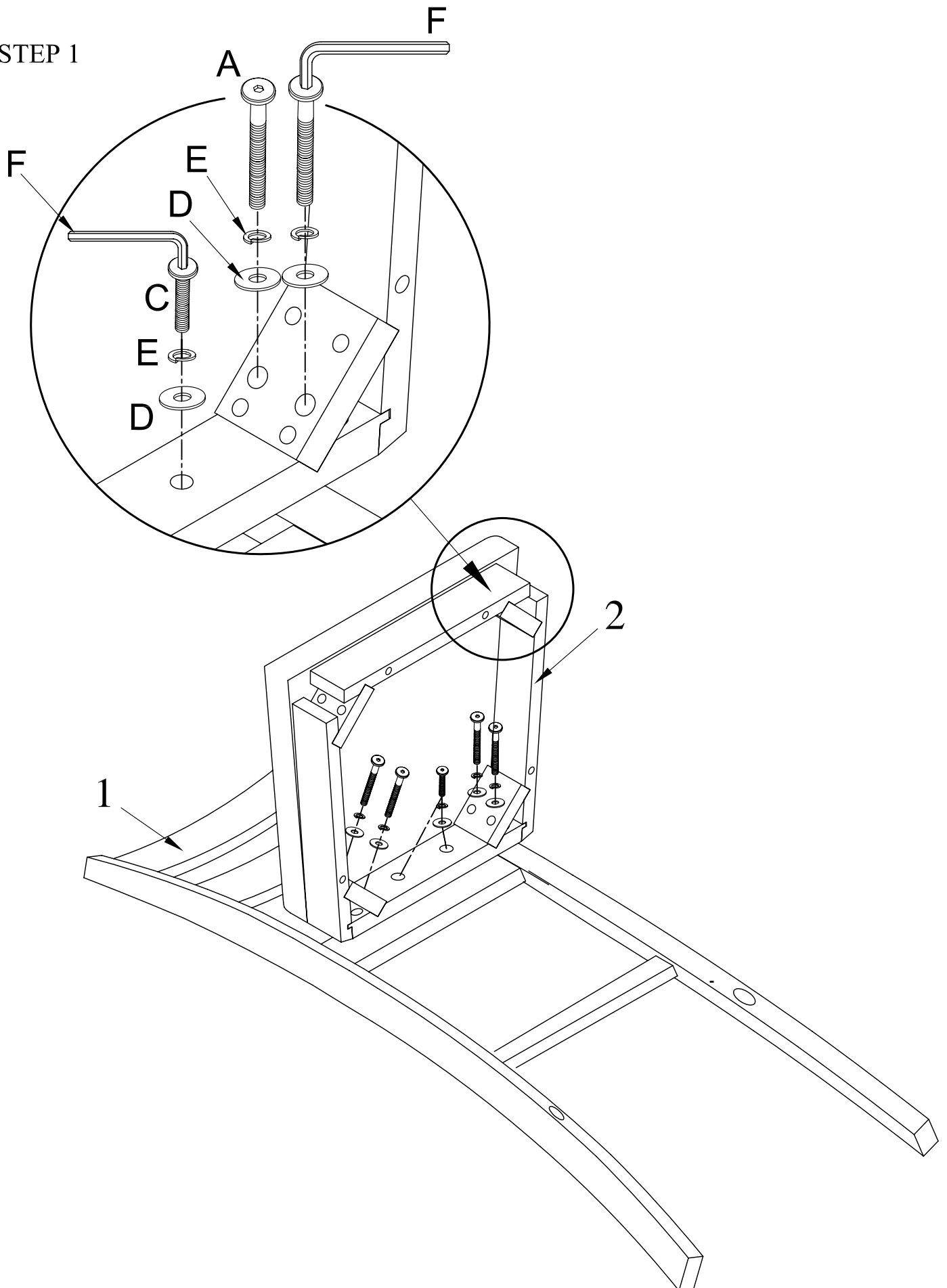

STEP 2

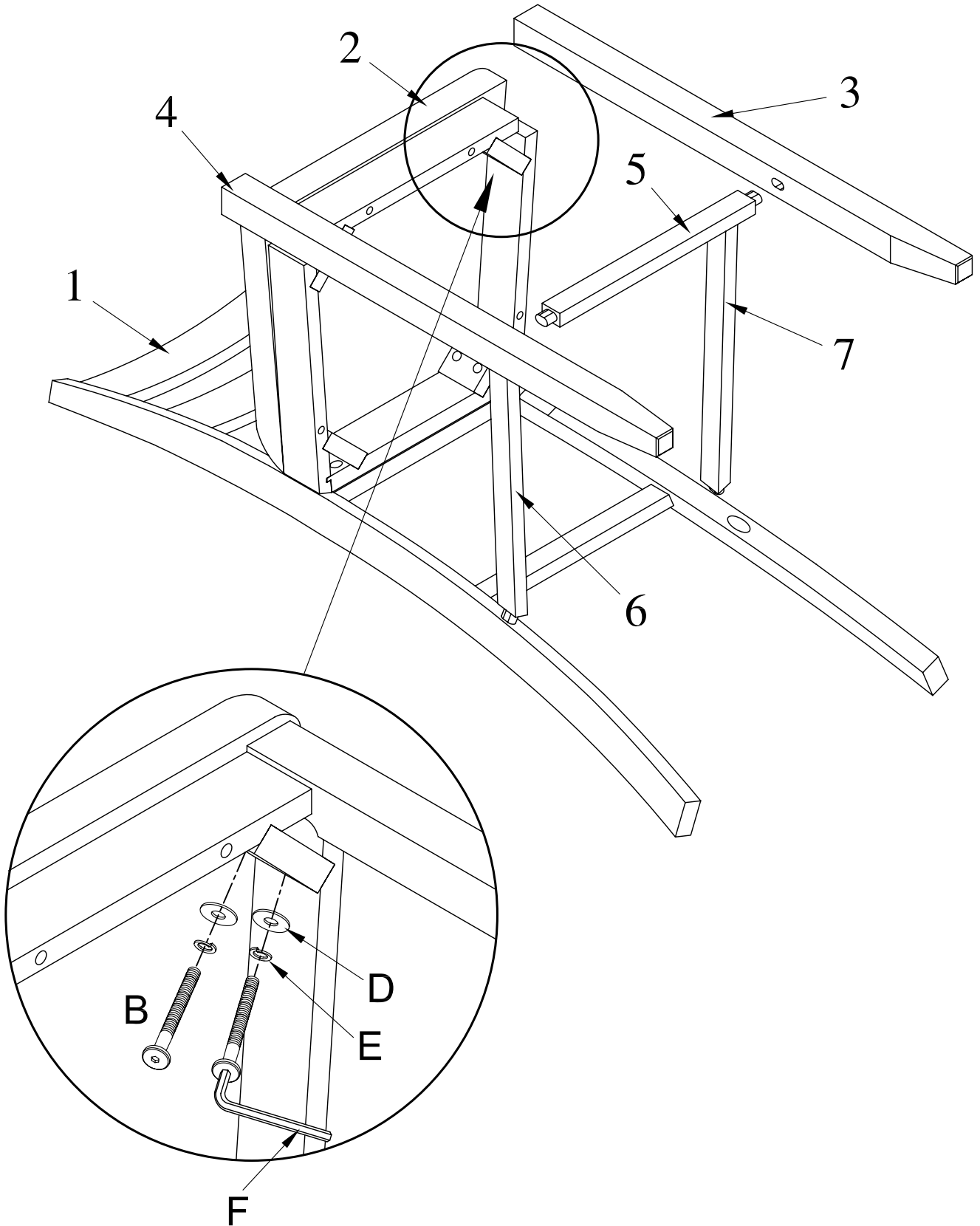

STEP 3

