

# ASSEMBLY INSTRUCTIONS

---

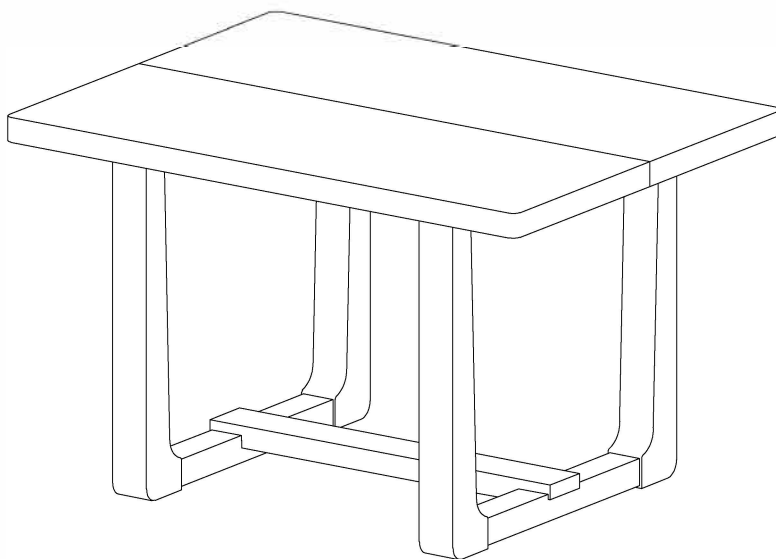

## TOOLS REQUIRED



Screwdriver  
( Not included)

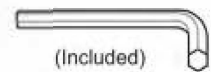

(Included)  
Allen Wrench

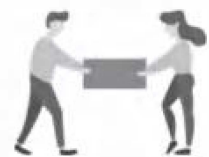

2 - People

## ASSEMBLY RATING



EASY —————> DIFFICULT

The Assembly Rating is a 5-point system showing the level of effort needed to assemble a specific product.

---

# DINING TABLE



- Please keep instructions for future reference.
- Check the quantity and irregularity of parts and hardware before you start.

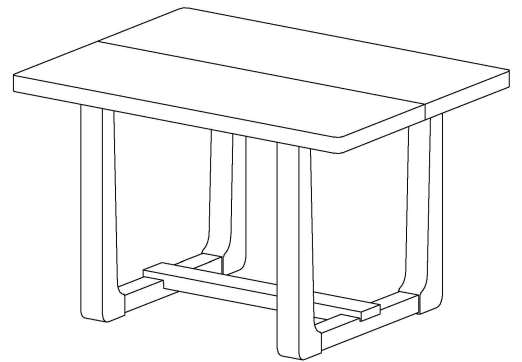

## PARTS

1

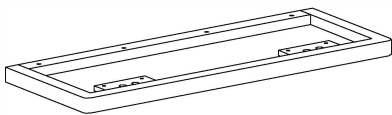

TOP  
2 pcs.

2

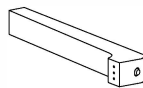

LEGS  
4 pcs.

3

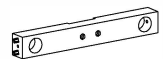

RAILS  
2 pcs.

4

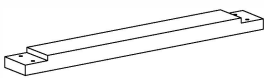

STRETCHER  
1 pc.

5

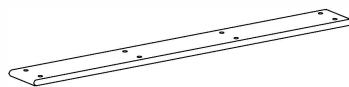

LONG CONNECTOR  
1 pc.

6

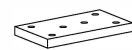

SHORT CONNECTOR  
4 pcs.

## HARDWARE

A

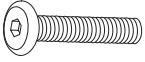

BOLT  
Ø5/16" x  
4 pcs.

B

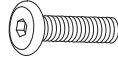

BOLT  
Ø5/16" x  
32 pcs.

C



SPRING WASHER  
Ø5/16"  
36 pcs.

D



FLAT WASHER  
Ø5/16"  
36 pcs.

E

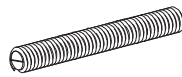

THREADED PINS  
Ø5/16" x 3"  
4 pcs.

F

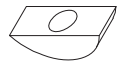

HALF MOON  
Ø5/16"  
4 pcs.

G



HEX NUT  
5/16" x 1/2"  
4 pcs.

H

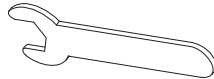

WRENCH  
3-1/2" x 1/2"  
1 pc.

I



ALLEN WRENCH  
M5  
1 pc.

J



WOOD DOWELS  
Ø10" x 30MM  
11 pcs.

---

# ASSEMBLY INSTRUCTIONS

## 1

DO NOT FULLY TIGHTEN ALL BOLTS UNTIL ASSEMBLY IS COMPLETED.

- Part 2 x4pcs
- Part 3 x2pcs
- Hardware E x4pcs
- Hardware F x4pcs
- Hardware G x4pcs
- Hardware H x1pc
- Hardware J x8pcs

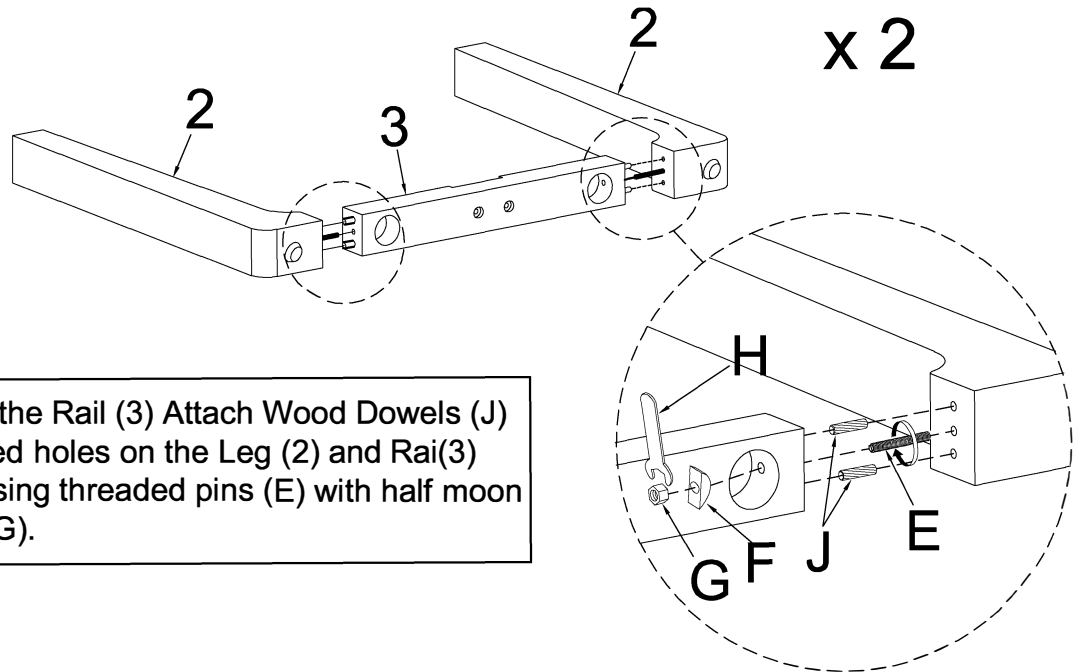

Align Legs (2) to the Rail (3) Attach Wood Dowels (J) into the designated holes on the Leg (2) and Rai(3) then secure by using threaded pins (E) with half moon (F) and hex nut (G).

## 2

- Part 6 x4pcs
- Hardware B x8pcs
- Hardware C x8pcs
- Hardware D x8pcs
- Hardware I x1pc

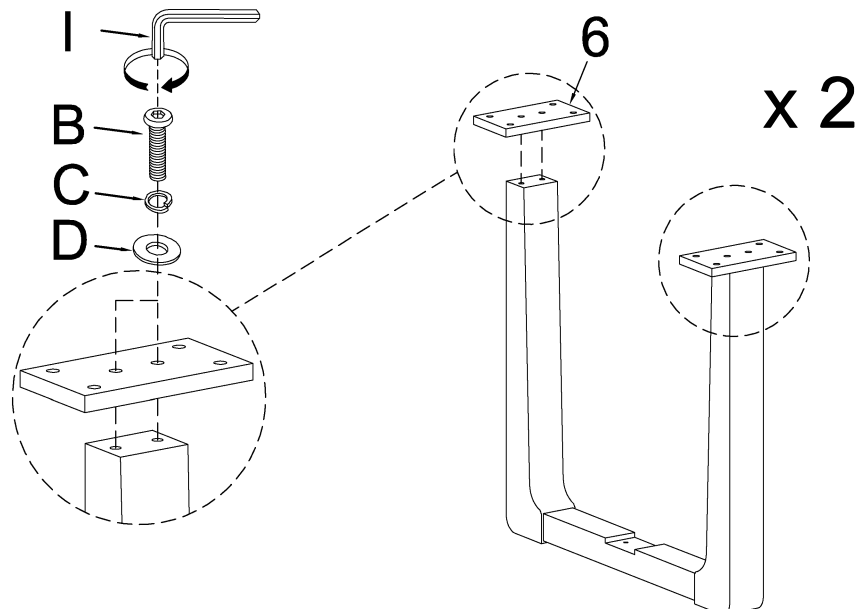

Align Short connector (6) to the Leg (2) then secure by using bolt (B) with Spring washer (C) and flat washer(D)

# ASSEMBLY INSTRUCTIONS

## 3

- Part 4 x1pc
- Hardware A x4pcs
- Hardware C x4pcs
- Hardware D x4pcs

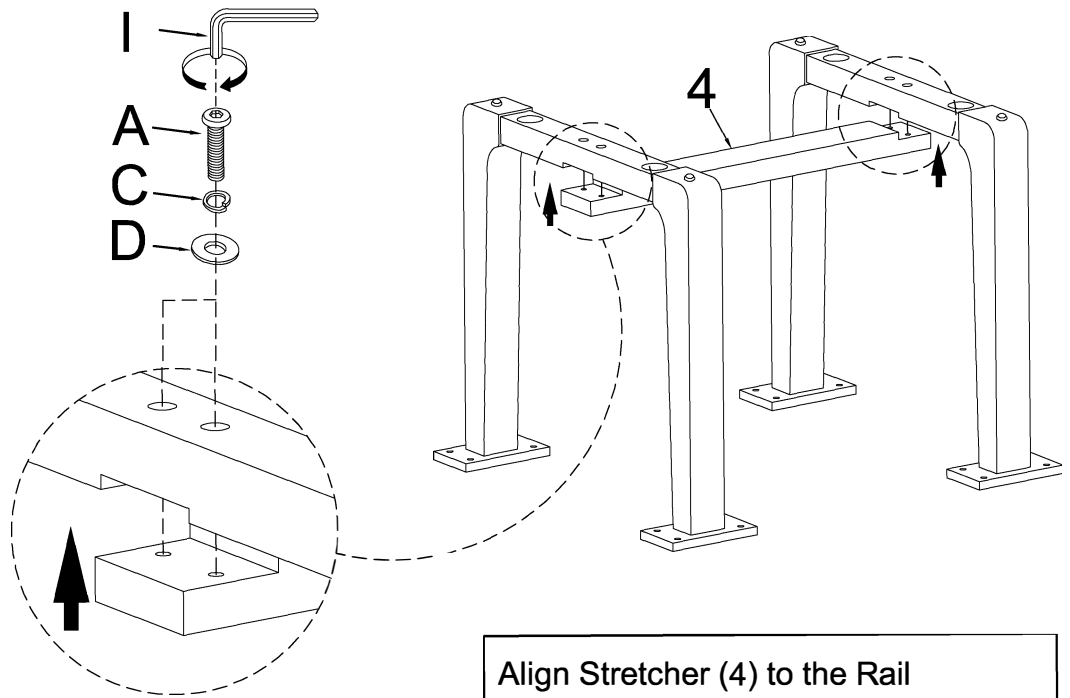

Align Stretcher (4) to the Rail (3) then secure by using bolt (A) with spring washer (C) and flat washer(D).

## 4

- Part 1 x2pcs
- Hardware J x3pcs

Align Attach Wood Dowels (J) into the designated holes on the two table tops (1)

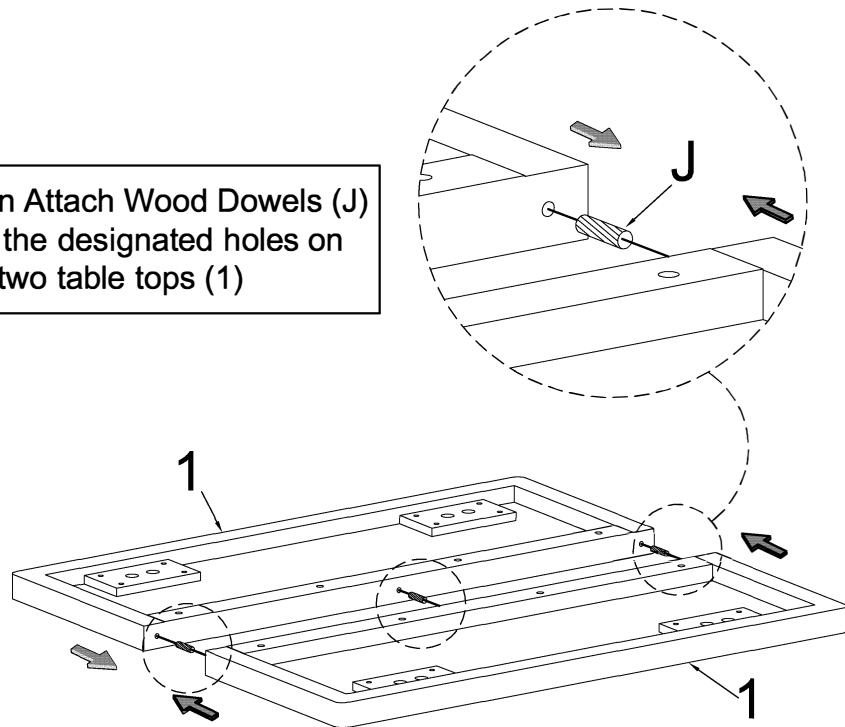

# ASSEMBLY INSTRUCTIONS

## 5

- Part 5 x1pc
- Hardware B x2pcs
- Hardware C x2pcs
- Hardware D x2pcs

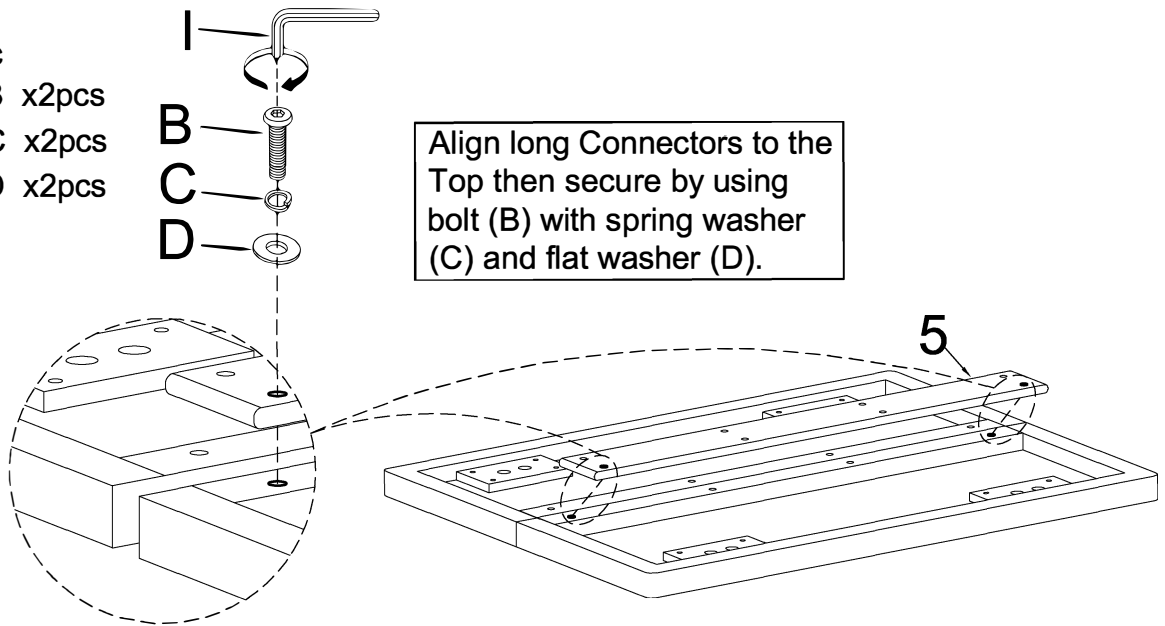

**Only tighten the 2 screws on the same side of the long board**

## 6

- Hardware B x6pcs
- Hardware C x6pcs
- Hardware D x6pcs

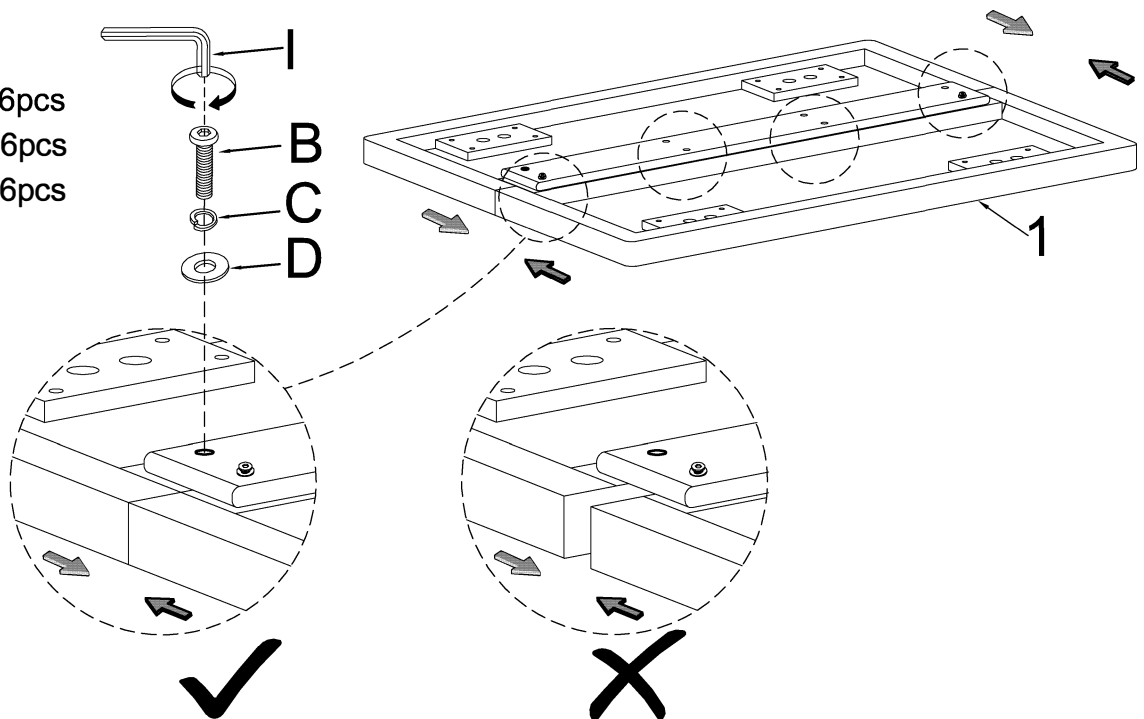

**Use your hands to pull the two tabletops closer together until there is no gap left, then secure by using bolt (B) with spring washer (C) and flat washer (D).**

# ASSEMBLY INSTRUCTIONS

## 7

Hardware B x16pcs

Hardware C x16pcs

Hardware D x16pcs

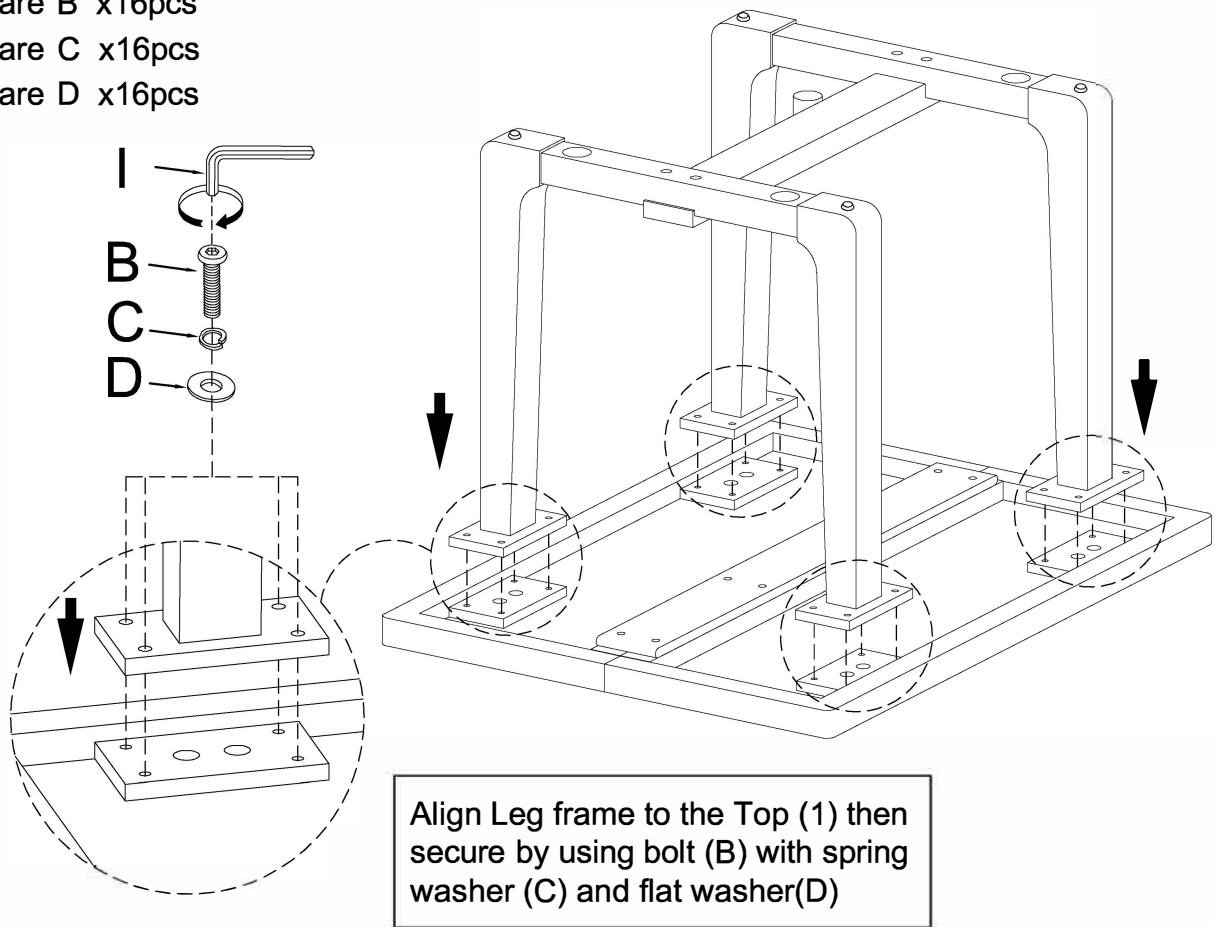

## 8

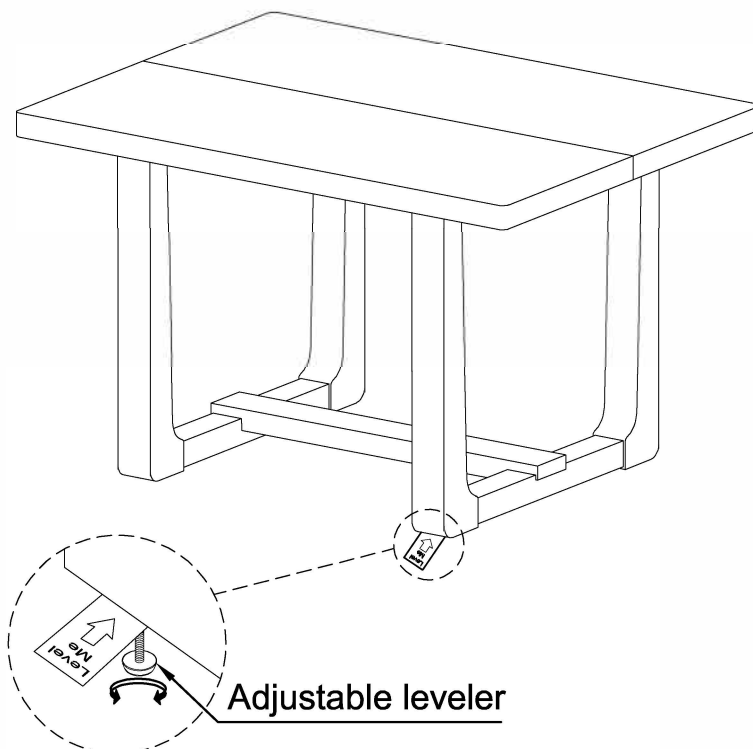

This product is intended for RESIDENTIAL USE ONLY and not for commercial use.