

Part List For Twin Headboard

HEADBOARD CARTONS

GRILL BOX

(5) GRILL (1)

POST BOX

(6) HEADBOARD POST(2)

PART HARDWARE BAG FOR HEADBOARD GRILL/POST AND FRAME ASSEMBLY

- (1) 1/4-20 X 3 1/2" FLAT ALLEN HEAD SCREW-(8)
- (2) 1/4-20 HEX NUT-4
- (3) 5/8" OD METAL WASHER-4
- (4) ALLEN WRENCH

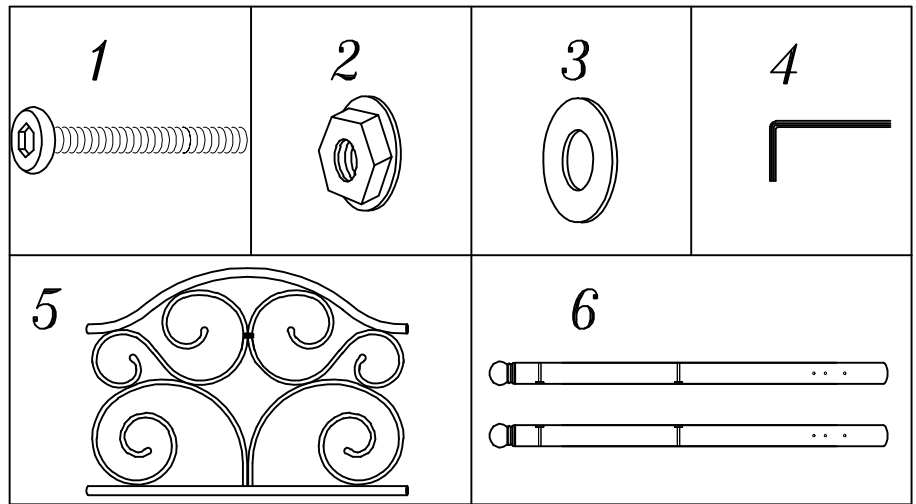

PRODUCT FULLY ASSEMBLED

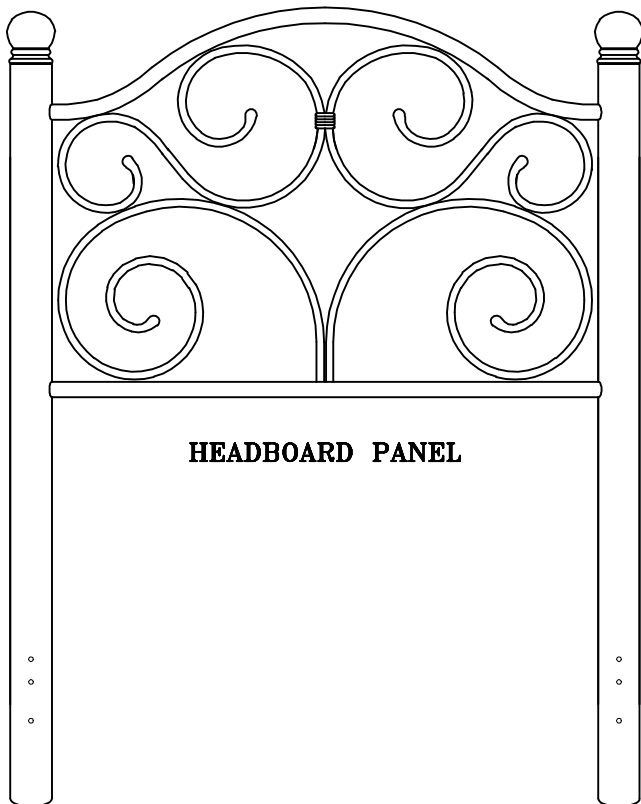

HEADBOARD PANEL

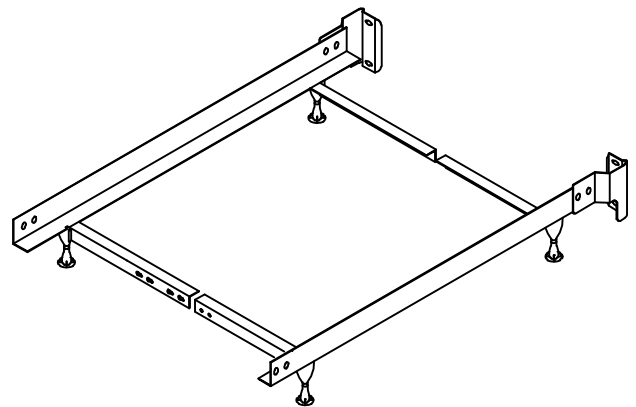

TWIN - FULL HEADBOARD ONLY FRAME FULLY ASSEMBLED

NOTE: SEE INSTRUCTIONS INCLUDED IN FRAME CARTON FOR FRAME ASSEMBLY

FOR ASSISTANCE IN ASSEMBLY ONLY OF THIS PRODUCT. CALL OUR HELP. PLEASE HAVE THE STYLE NUMBER AVAILABLE BEFORE YOU CALL. (STYLE # OR NAME CAN BE FOUND ON PACKING CARTON OR SALES RECEIPT.) OUR PRODUCT IS INSPECTED TO ENSURE IT IS IN GOOD CONDITION. IF YOUR FURNITURE APPEARS TO HAVE BEEN DAMAGED IN SHIPMENT OR YOU ARE IN NEED OF REPLACEMENT PARTS PLEASE CONTACT THE DEALER FROM WHOM YOU PURCHASED THE PRODUCT.

Instruction Sheet

SAVE ALL PACKAGING MATERIALS UNTIL PRODUCT IS FULLY ASSEMBLED. HARDWARE AND SMALL PIECES MAY NOT BE SEEN AND COULD BE ACCIDENTALLY DISCARDED WITH PACKAGING MATERIALS.

FIGURE 1

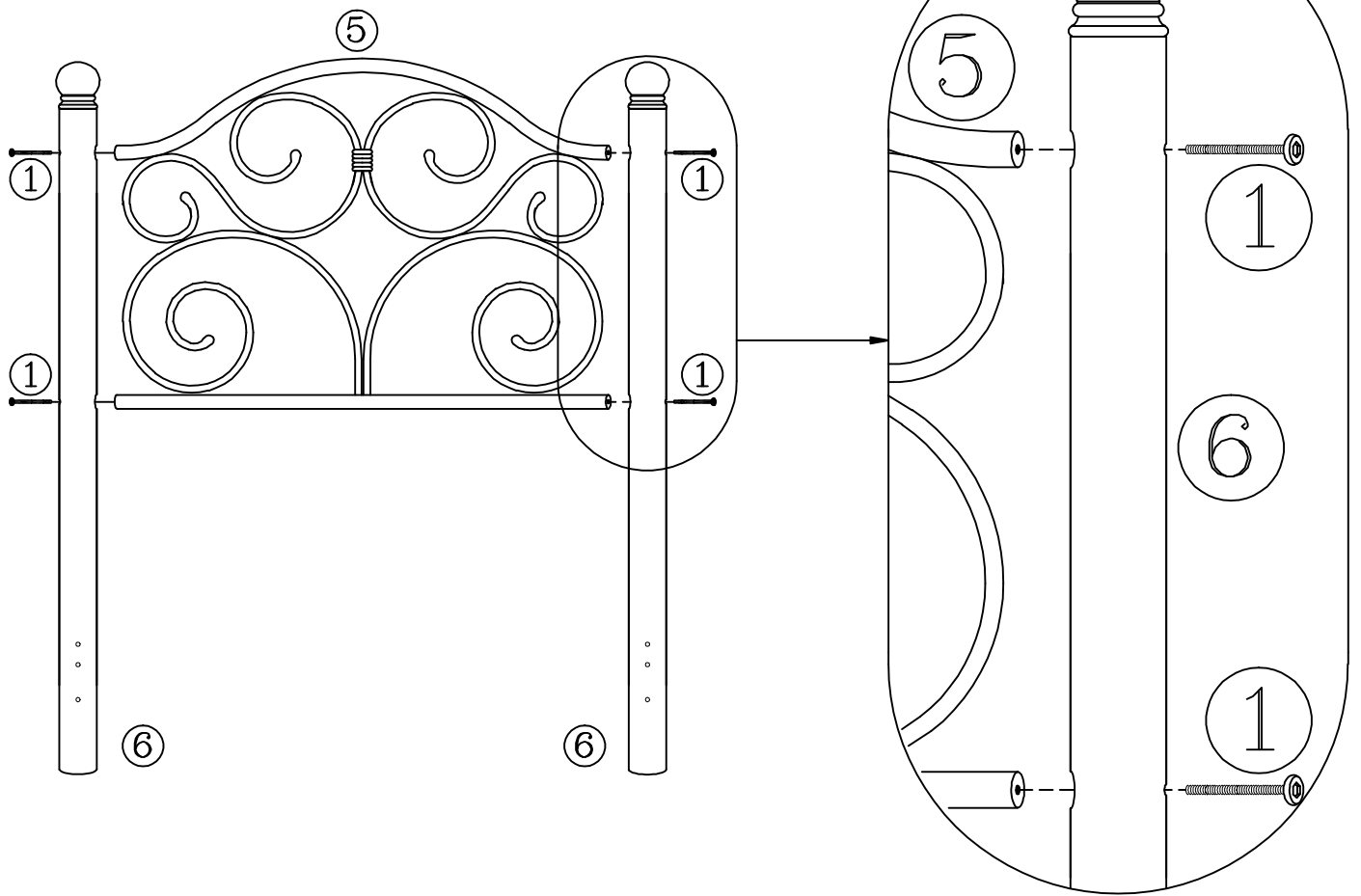
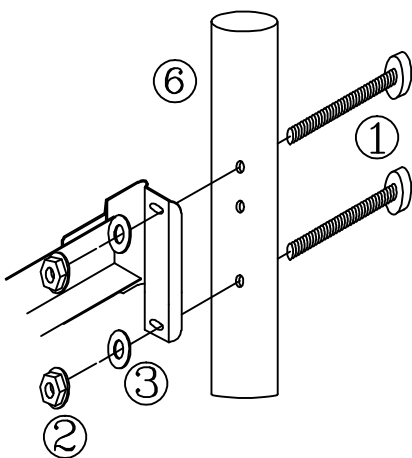

FIGURE 2



Step 1

- Align grill (5) rail ends with holes in headboard post (6). See Figure 1
- Secure post (6) to grill (5) with screws (1). See Figure 1
- Repeat on other side of headboard panel.
- Tighten all screws securely using the Allen wrench (4).

Step 2

- Place headboard and frame in desired location in room.
- Place 2 screws (1) through holes located in post (6). See Figure 2
- Align bed frame bracket over screws.
- Place a washer (3) first and then a nut (2) on each screw. Hand-tighten, DO NOT TIGHTEN screws all the way.
- Repeat on other side of headboard.
- Tighten all screws securely using the Allen wrench (4).

Part List For Bed

BED CARTONS

GRILL BOX

(5) GRILL (2)

POST BOX

(6) HEADBOARD POST(2)
(7) FOOTBOARD POST(2)

PART HARDWARE BAG FOR BED
GRILLS/POST AND FRAME ASSEMBLY

(1) 1/4-20 X 3 1/2" LONG FLAT ALLEN HEAD SCREW-16
(2) 1/4-20 HEX NUT-8
(3) 5/8" OD METAL WASHER-8
(4) ALLEN WRENCH

HEADBOARD CARTONS

GRILL BOX

(5) GRILL (1)

POST BOX

(6) HEADBOARD POST(2)

PART HARDWARE BAG FOR BED
GRILLS/POST AND FRAME ASSEMBLY

(1) 1/4-20 X 3 1/2" LONG FLAT ALLEN HEAD SCREW-(8)
(2) 1/4-20 HEX NUT-4
(3) 5/8" OD METAL WASHER-4
(4) ALLEN WRENCH

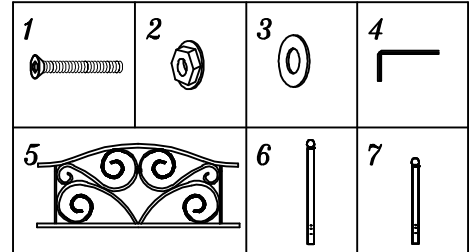

PRODUCT FULLY ASSEMBLED

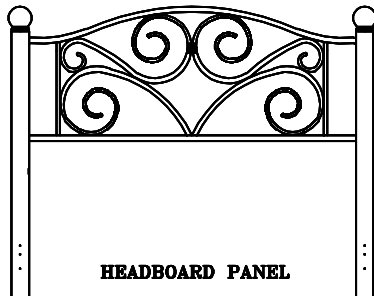

HEADBOARD PANEL

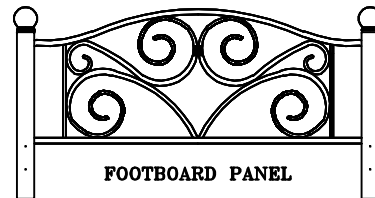

FOOTBOARD PANEL

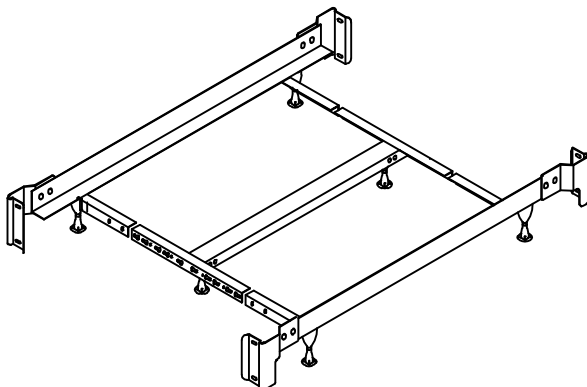

QUEEN - KING FRAME FULLY ASSEMBLED

NOTE: SEE INSTRUCTIONS INCLUDED IN FRAME CARTON
FOR FRAME ASSEMBLY

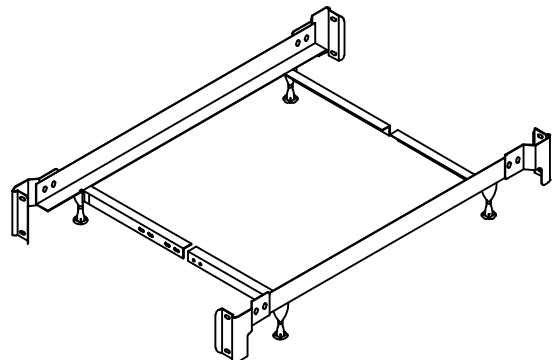

TWIN - FULL FRAME FULLY ASSEMBLED

NOTE: SEE INSTRUCTIONS INCLUDED IN FRAME CARTON
FOR FRAME ASSEMBLY

FOR ASSISTANCE IN ASSEMBLY ONLY OF THIS PRODUCT. CALL OUR HELP DESK. PLEASE HAVE THE STYLE NUMBER AVAILABLE BEFORE YOU CALL. (STYLE # OR NAME CAN BE FOUND ON PACKING CARTON OR SALES RECEIPT.) OUR PRODUCT IS INSPECTED TO ENSURE IT IS IN GOOD CONDITION. IF YOUR FURNITURE APPEARS TO HAVE BEEN DAMAGED IN SHIPMENT OR YOU ARE IN NEED OF REPLACEMENT PARTS PLEASE CONTACT THE DEALER FROM WHOM YOU PURCHASED THE PRODUCT.

Instruction Sheet

SAVE ALL PACKAGING MATERIALS UNTIL PRODUCT IS FULLY ASSEMBLED. HARDWARE AND SMALL PIECES MAY NOT BE SEEN AND BE ACCIDENTALLY DISCARDED WITH PACKAGING MATERIALS.

FIGURE 1

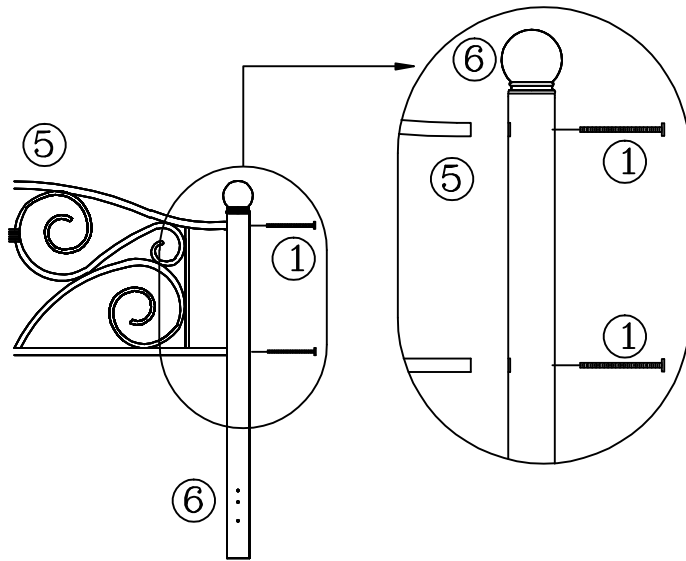

FIGURE 2

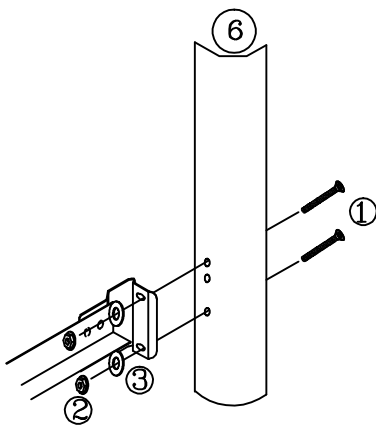
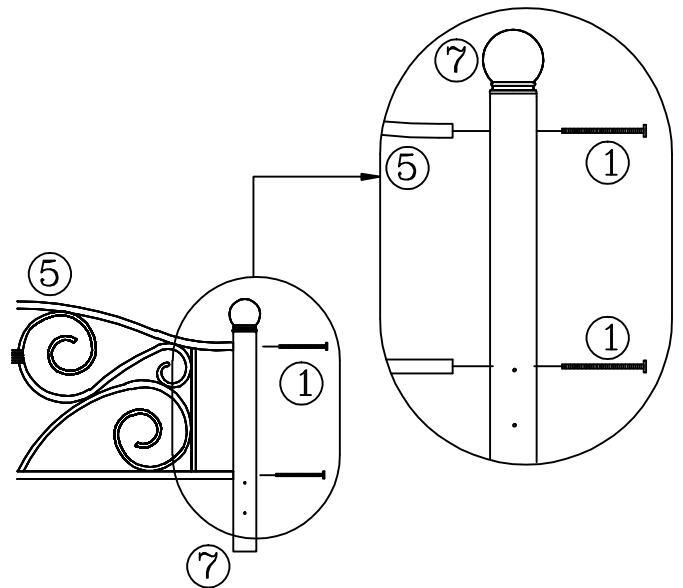

FIGURE 3

Step 1

- Align grill (5) rail ends with holes in headboard post (6). See Figure 1
- Secure post (6) to grill (5) with screws (1). See Figure 1
- Repeat on other side of headboard panel.
- Tighten all screws securely using the Allen wrench.
- Repeat same step for assembly of footboard. (See Figure 2)

Step 2

- Place headboard and frame in desired location in room.
- Place 2 screws (1) through holes located in post (6). (See Figure 3)
- **Align bed frame bracket over screws.**
- Place a washer (3) first and then a nut (2) on each screw. Hand-tighten, DO NOT TIGHTEN screws all the way.
- Repeat on other side of headboard.
- Tighten all screws securely using the Allen wrench (4).

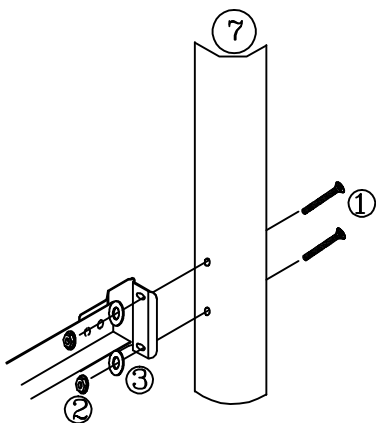

FIGURE 4

Step 3

- Position footboard panel and align holes in the post (7) with holes in the frame bracket. See Figure 4
- Place 2 screws (1) through holes located in post (7). (See Figure 4)
- **Align bed frame bracket over screws.**
- Place a washer (3) first and then a nut (2) on each screw. Hand-tighten, DO NOT TIGHTEN screws all the way.
- Repeat on other side of footboard.
- Tighten all screws securely using the Allen wrench (4).