

ASSEMBLY INSTRUCTION EXTENSION ROUND TABLE

1

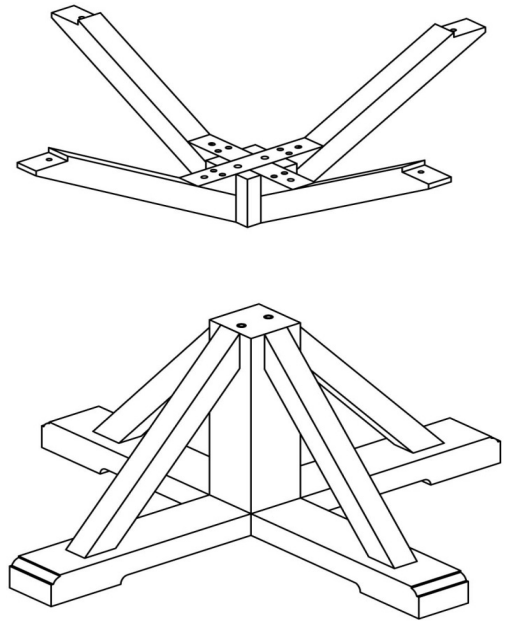

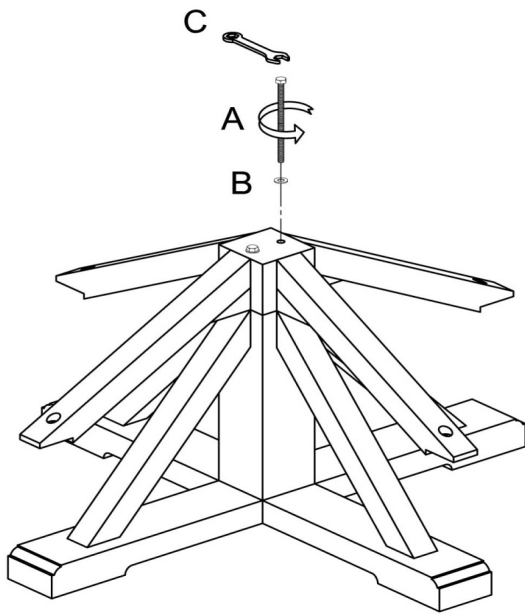

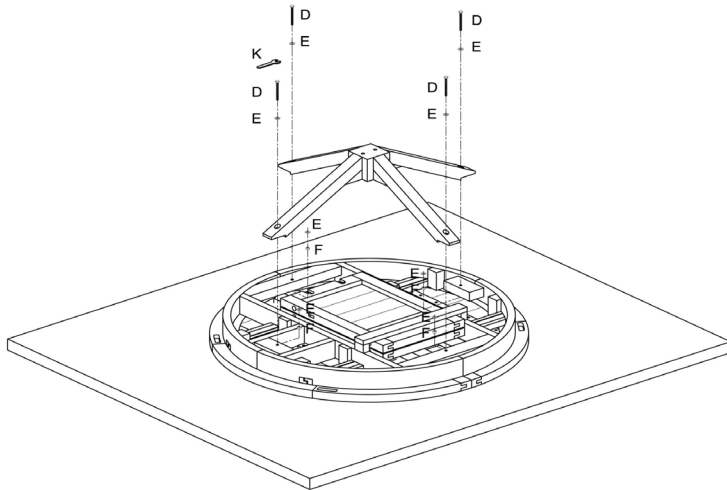

Assembly requires two adults.

Remove two part which are connected by ring spanner ©, do not use power tool.

2



	HARDWARE		QUANTITY
D	BOLT Φ 8 x 80		4
E	WASHER Φ 8 x 19 x 1.2		8
F	NUT Φ 10		4
K	RING SPANNER K13 x 28 x 90		1

We suggest to place the table upside down on a blanket to protect it from scratching.

Connect support leg with table top by bolts (D), washers (E) and nut (F).

Tighten all bolts by using ring spanner (K)

©

No person or organization is permitted to reproduce or modify under any circumstances wherever and however displayed without written

ASSEMBLY INSTRUCTION EXTENSION ROUND TABLE

3

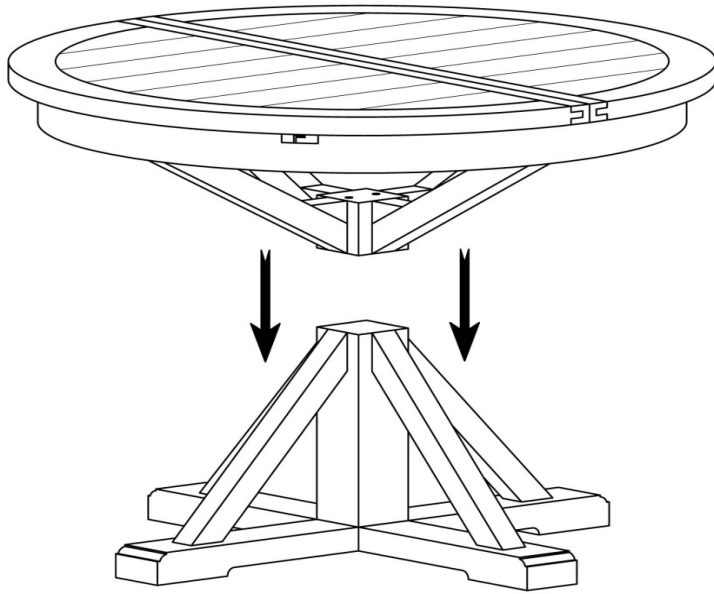

Put the table top on pedestal leg

4

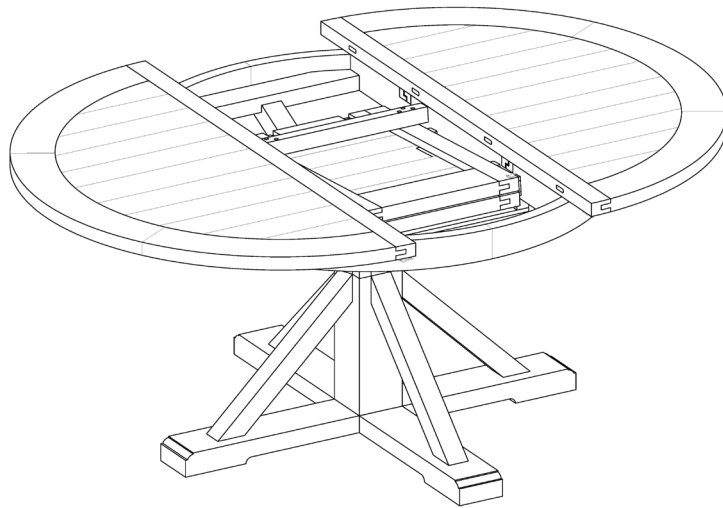





Open the table top, which is magnetically held at the centre

©

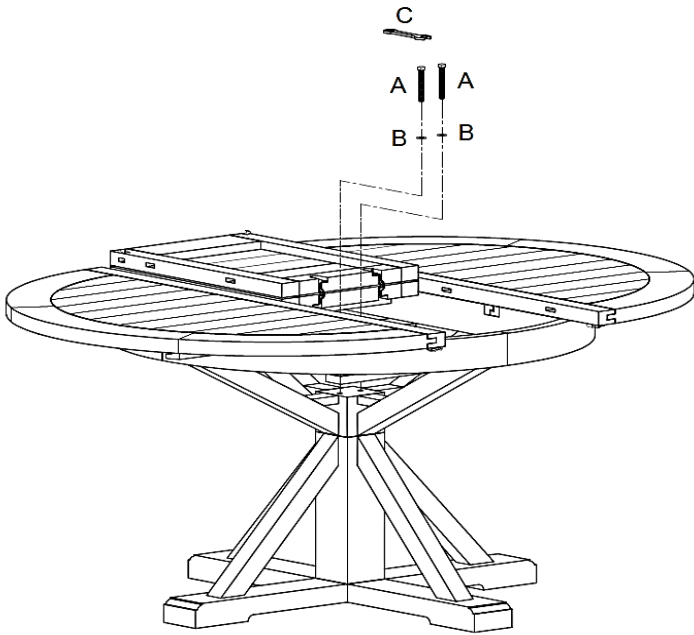
ASSEMBLY INSTRUCTION EXTENSION ROUND TABLE

5



HARDWARE			QUANTITY
A	BOLT Φ 10 x 150		2
B	WASHER Φ 11 x 26 x 1.8		2
C	RING SPANNER K17 x 25 x 135		1

Attach the table top and pedestal leg using bolt (A) and washer (B)
Tighten both bolts by using ring spanner (C), do not use power tool

6

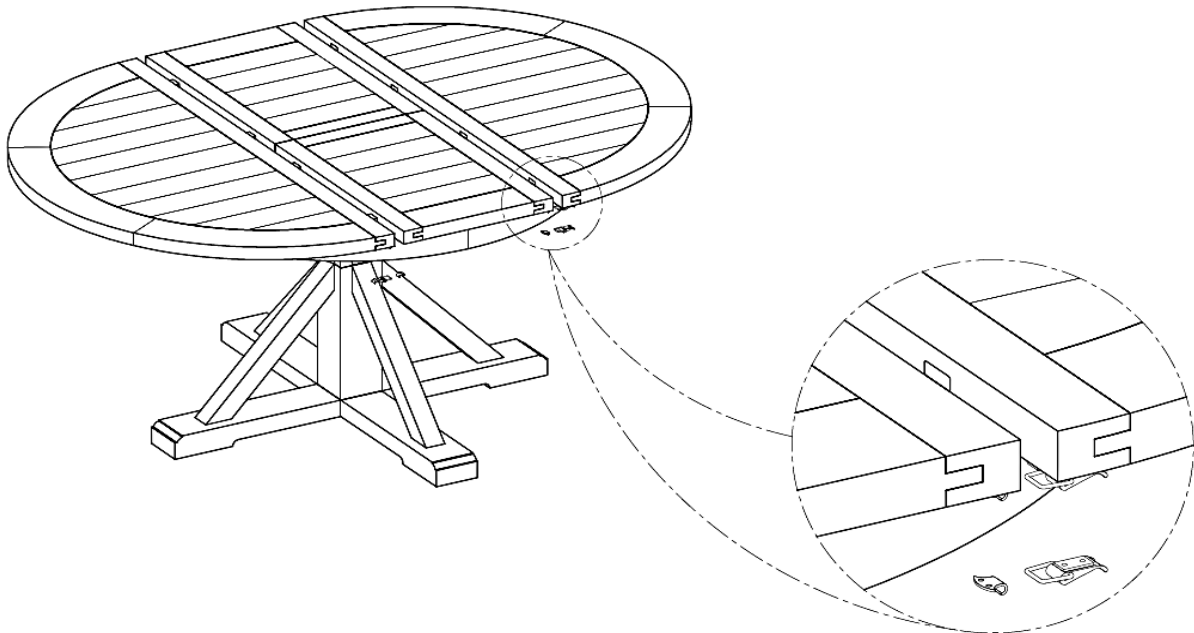

Fully open the leaf and close the table top

©

No person or organization is permitted to reproduce or modify under any circumstances wherever and however displayed without written

**ASSEMBLY INSTRUCTION
EXTENSION ROUND TABLE**

7

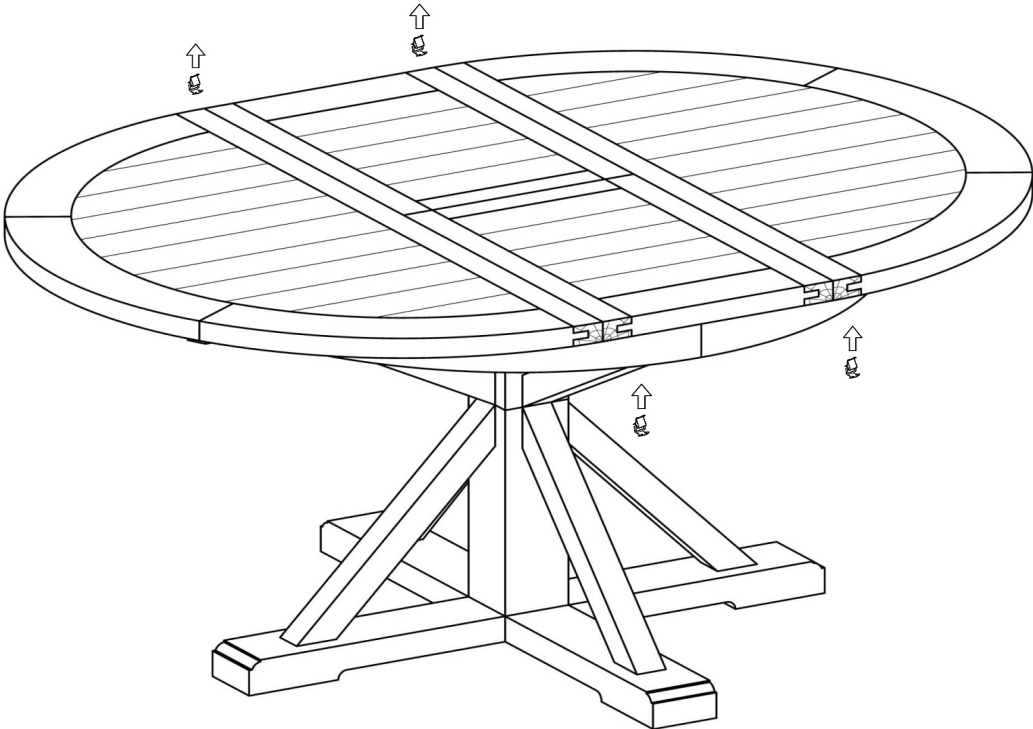

©

— FINISH —

No person or organization is permitted to reproduce or modify under any circumstances wherever and however displayed without written