

Assembly Instructions

Before beginning the assembly process, please read and save these instructions for reference. Following these guidelines will ensure a smooth and successful assembly of your product.

1. Part Identification:

Carefully separate and identify all the parts included in your package. Confirm that you have all the components listed in the instruction manual. This step will help you avoid any missing or misplaced parts during assembly.

2. Work Surface:

To prevent any scratches or damage to the product, assemble it on a soft mat or a similar protective surface. This will provide a cushioned area for the components and protect the surfaces from unwanted marks.

3. Step-by-Step Assembly:

Follow the assembly instructions provided, proceeding one step at a time. Take care to understand each step properly before proceeding to the next one. This sequential approach ensures that the assembly is done correctly and minimizes the chance of errors.

4. Proper Screw Seating:

When attaching screws and nuts, it is essential not to fully tighten them until all screws are correctly seated. By partially tightening each screw and nut initially, you can ensure that they are aligned properly and fit securely before final tightening.

5. Avoid Over-Tightening:

While each screw and nut should be tightened correctly, it is crucial not to over-tighten them. Over-tightening can cause damage to the product or compromise its structural integrity. Use the appropriate amount of force to secure the components without excessive tightening.

Parts List

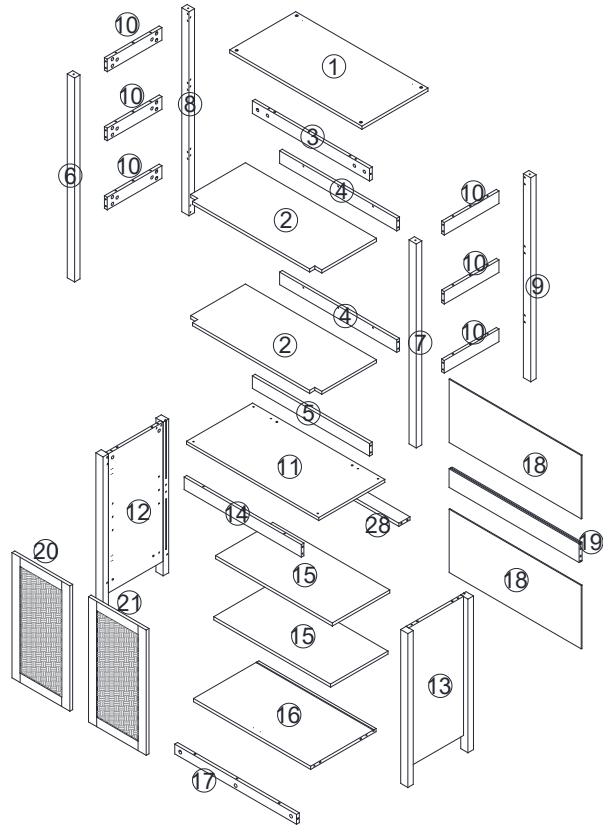

Hardware List

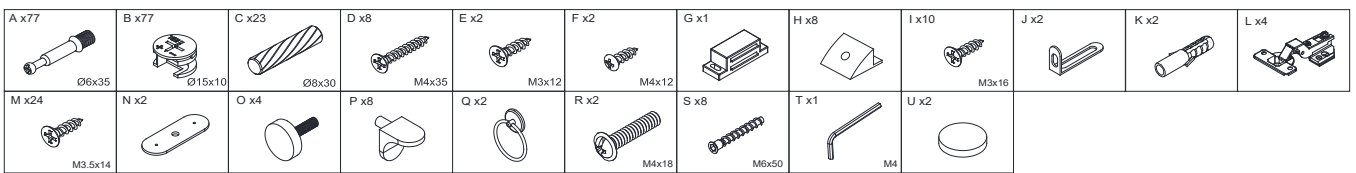

Code	Description	Quantity
A	Cam bolt	77+4
B	Cam lock	77+4
C	Wooden dowel	23+2
D	M4x35MM Screw	8+2
E	M3x12MM Screw	2+1
F	M4x12MM Screw	2+1
G	Magnet	1
H	Back clip	8+2
I	M3x16MM Screw	10+2
J	Anti falling iron sheet	2
K	Plastic anchor	2
L	Hinge	4

Code	Description	Quantity
M	M3.5x14MM Screw	24+2
N	Magnet plate	2
O	Adjusting the footrest	4+1
P	Metal Pin	8+1
Q	Handle	2
R	M4x18MM bolt	2+1
S	M6x50MM bolt	8+2
T	Wrench	1
U	Cushion	2

Step 1

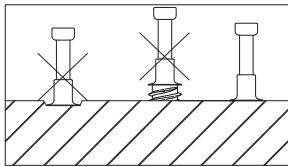
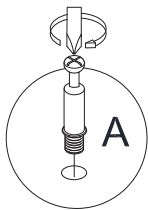
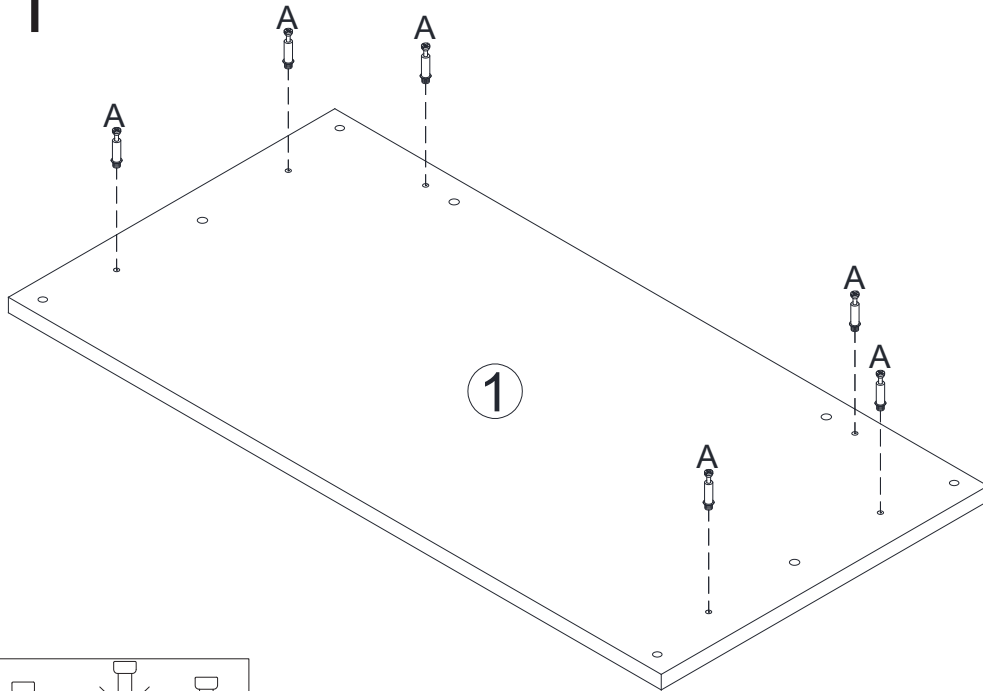

A

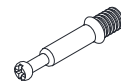

X 6

Step 2

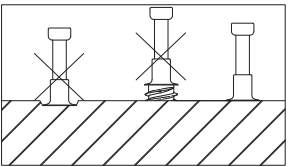
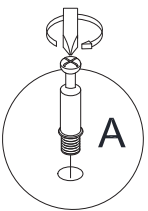
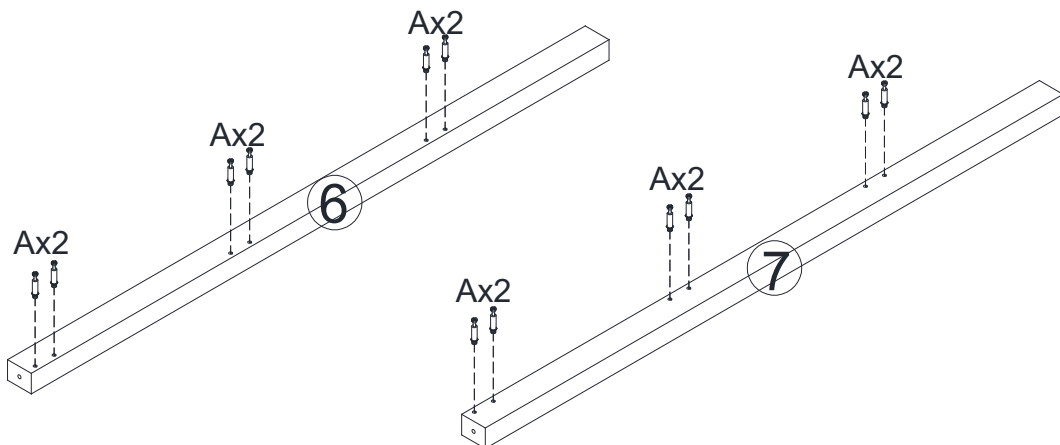

A



X 12

Step 3

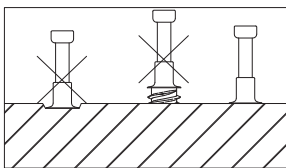
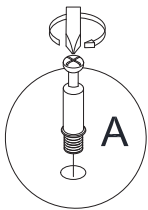
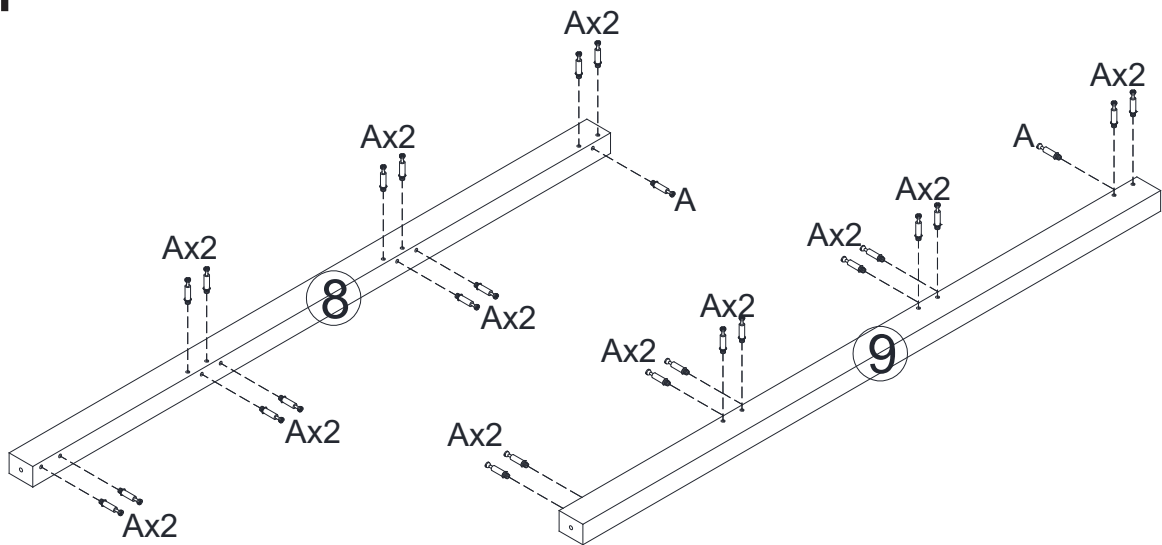

A



X 26

Step 4

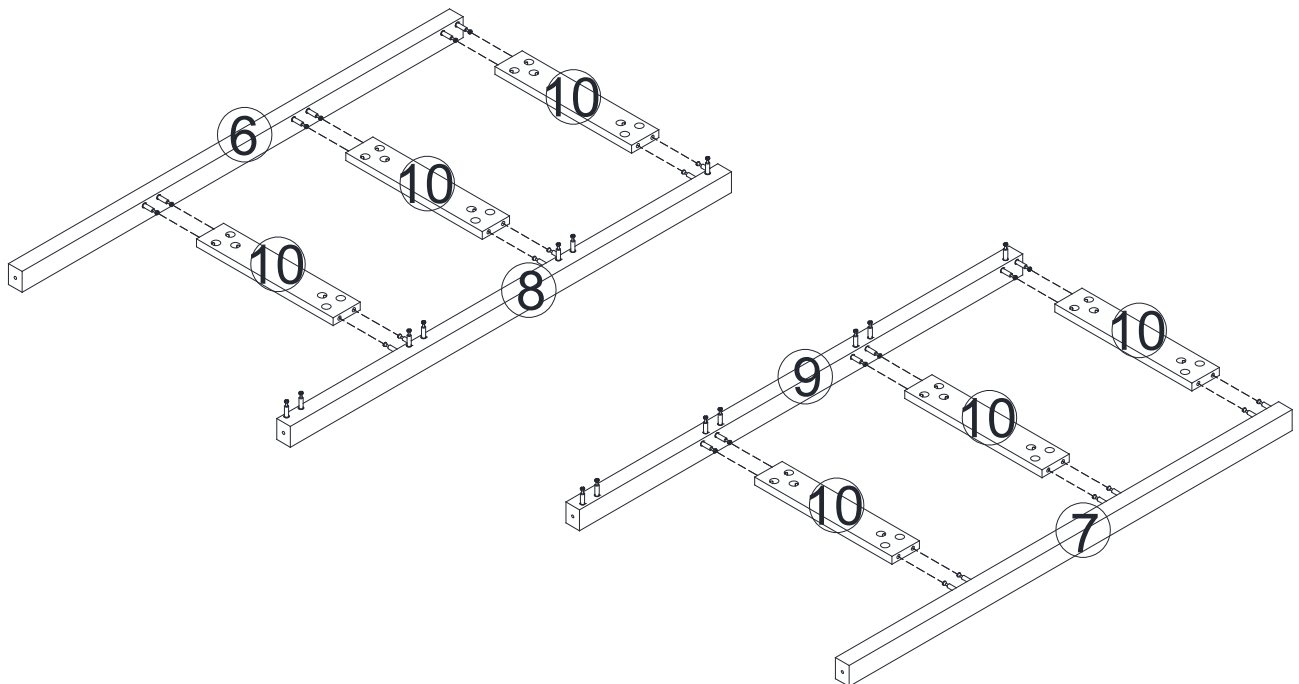

Step 5

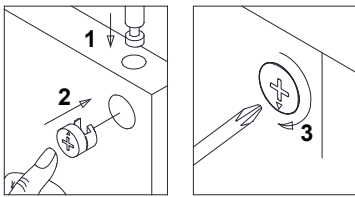
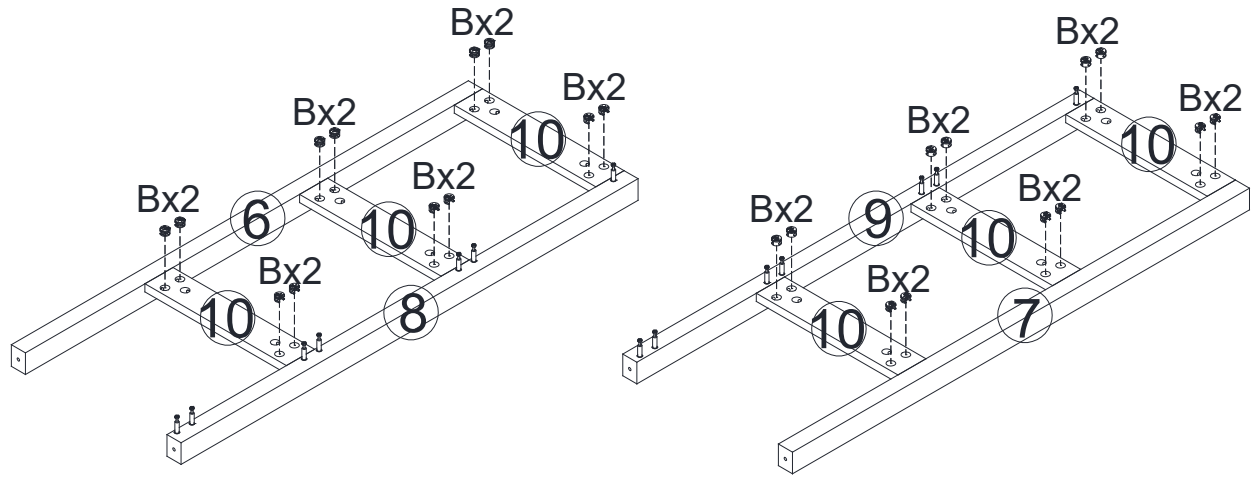

B



X 24

Step 6

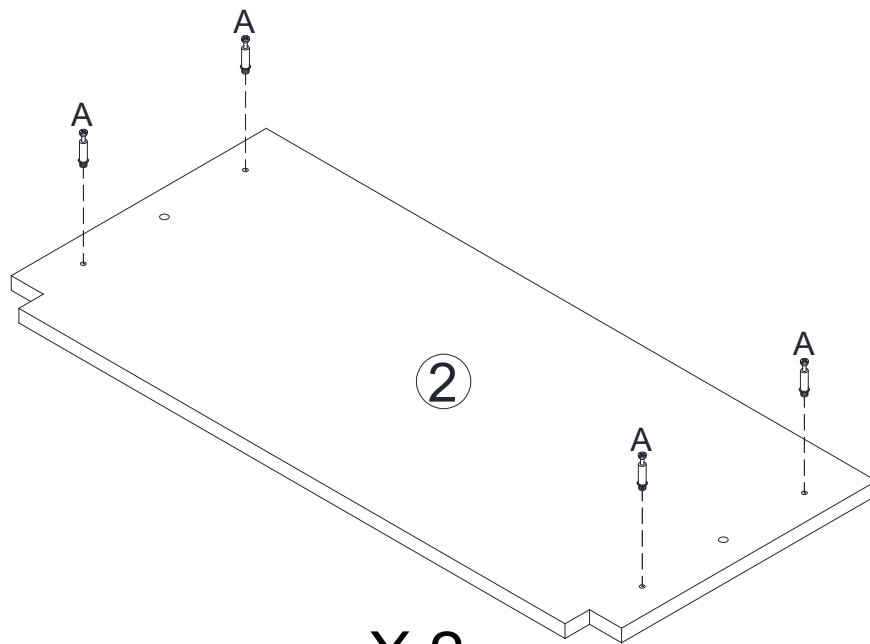

X 2

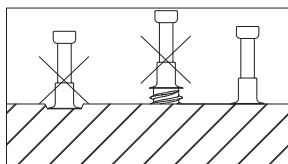
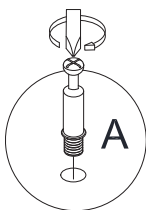

A

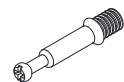

X 8

Step 7

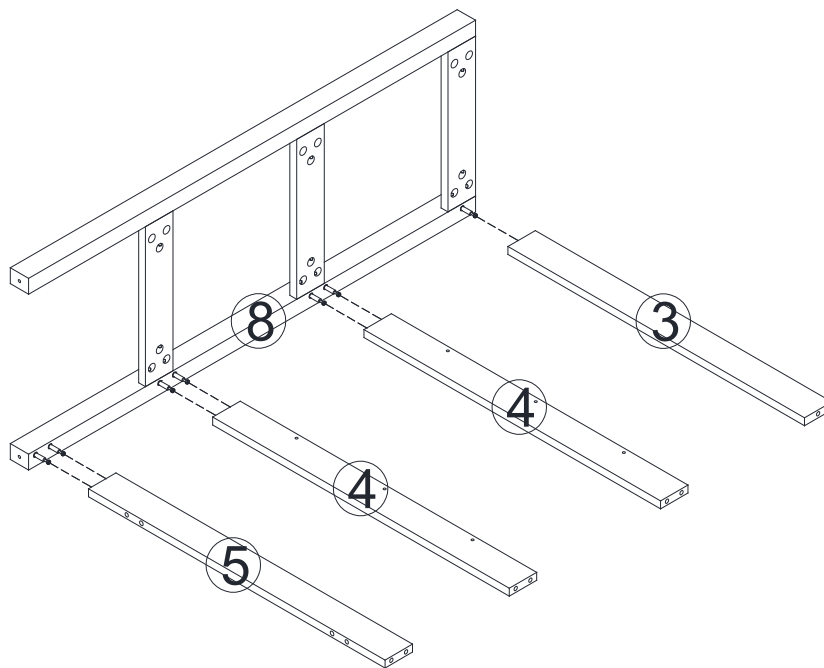

Step 8

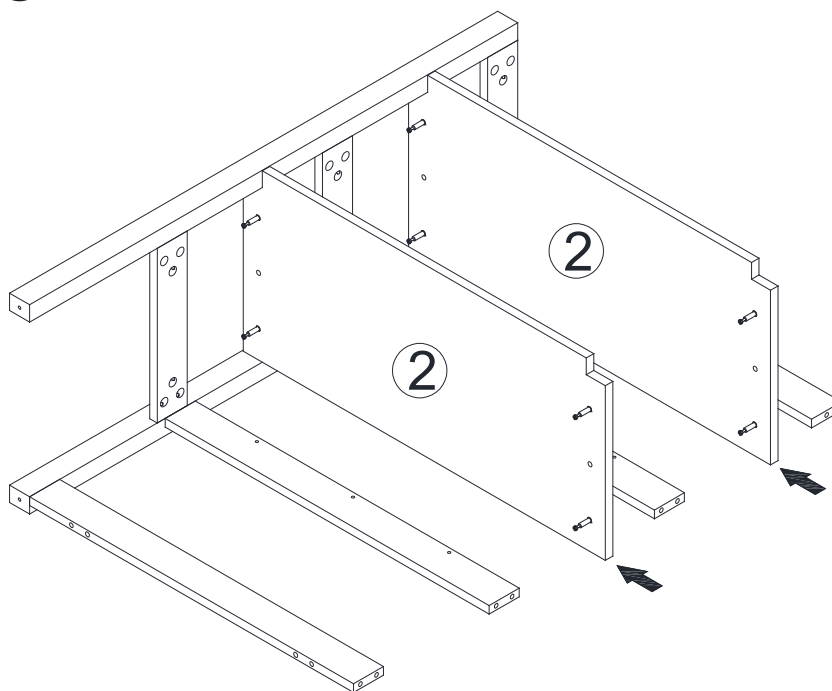

Step 9

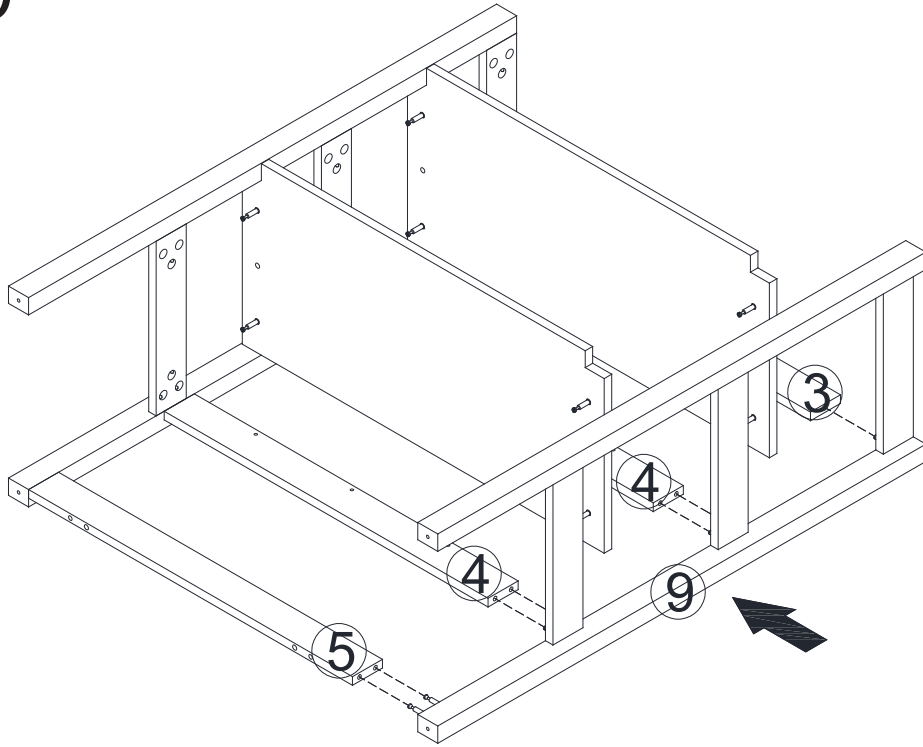

Step 10

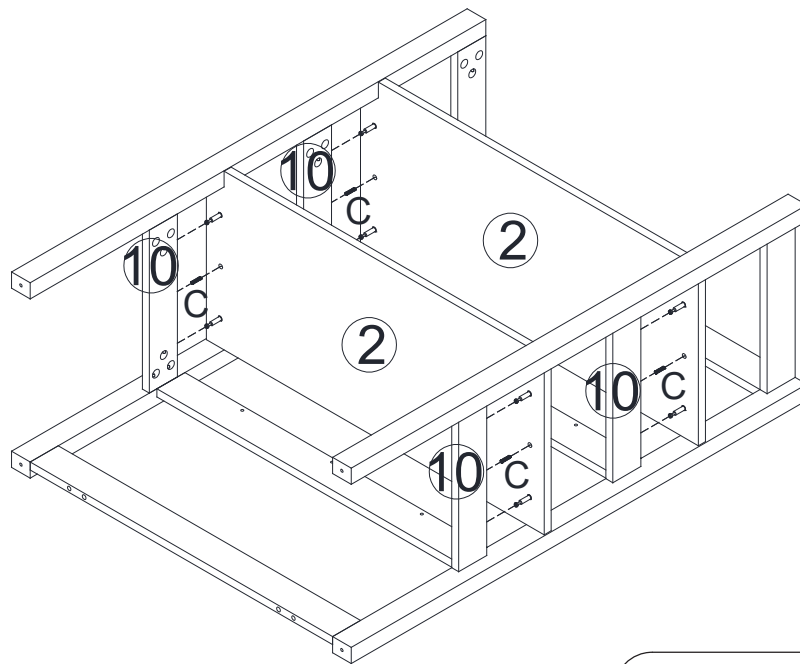

C



X 4

Step 11

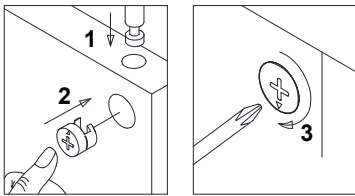
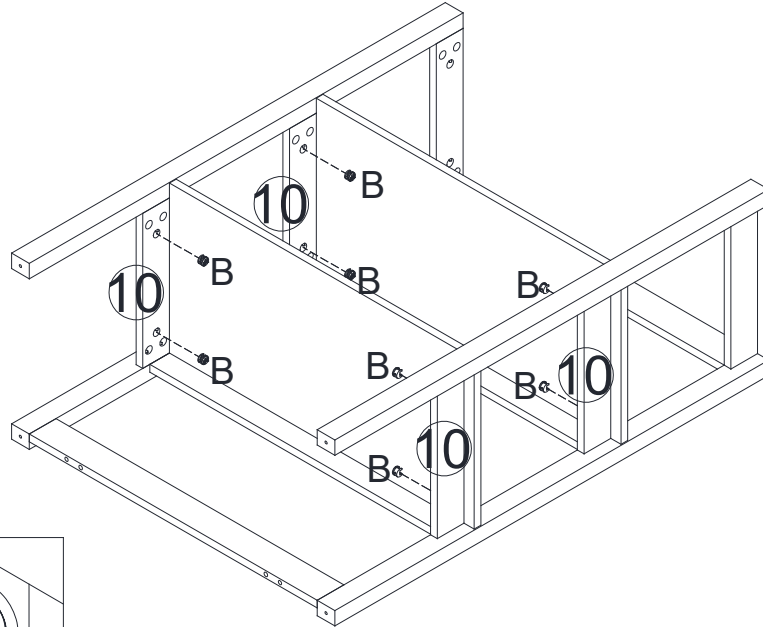

B



X 8

Step 12

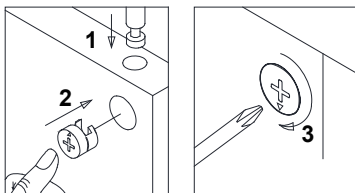
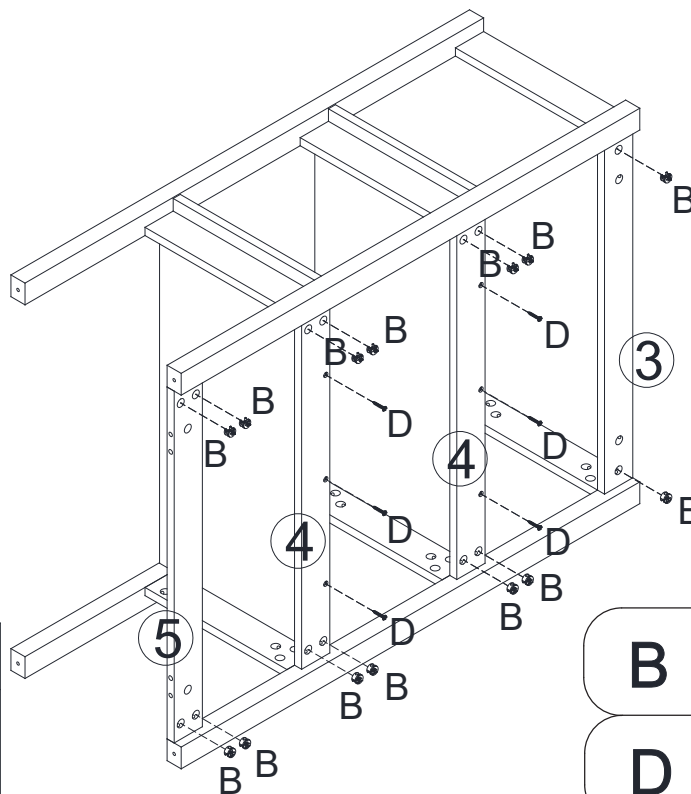

B



X 14

D



X 6

Step 13

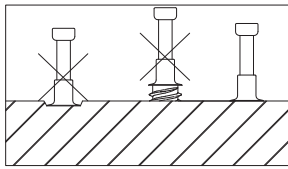
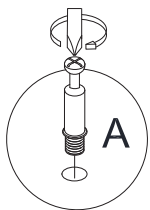
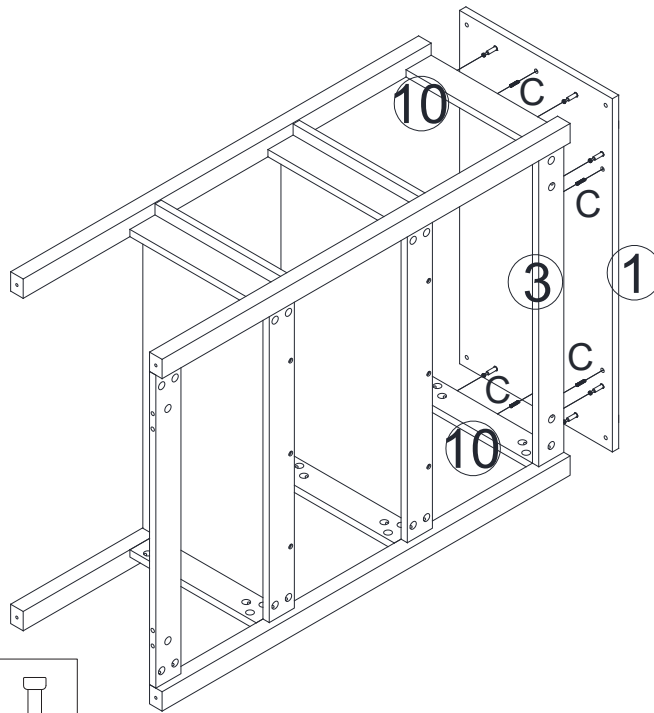

C  X 4

Step 14

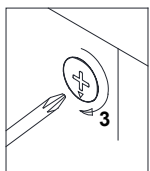
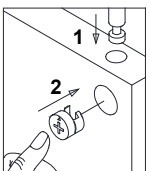
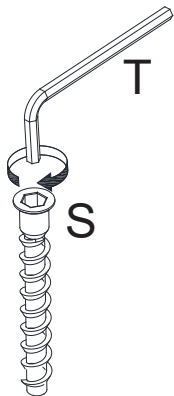
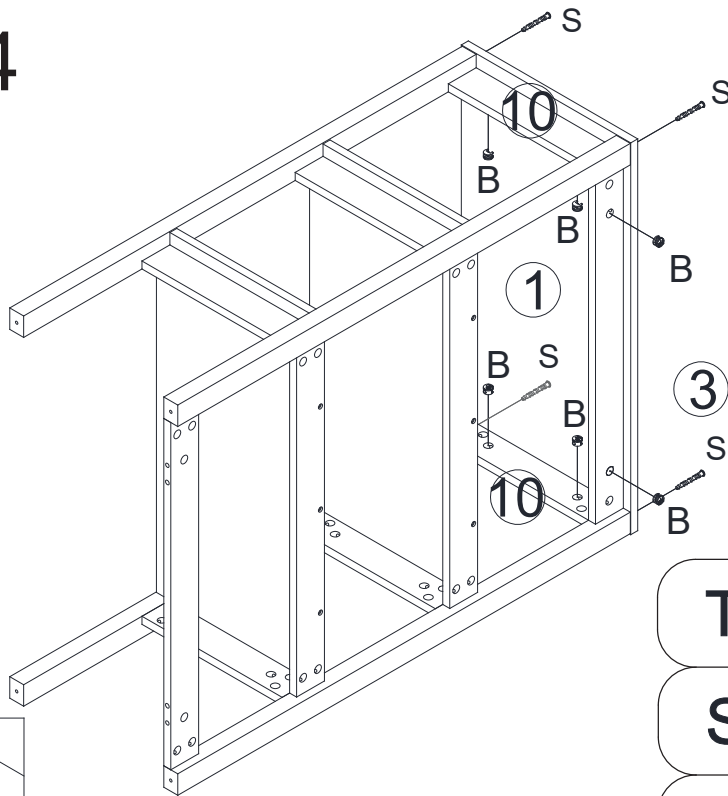

T  X 1

S  X 4

B  X 6

Step 15

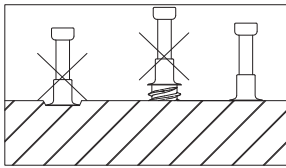
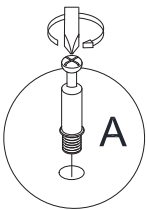
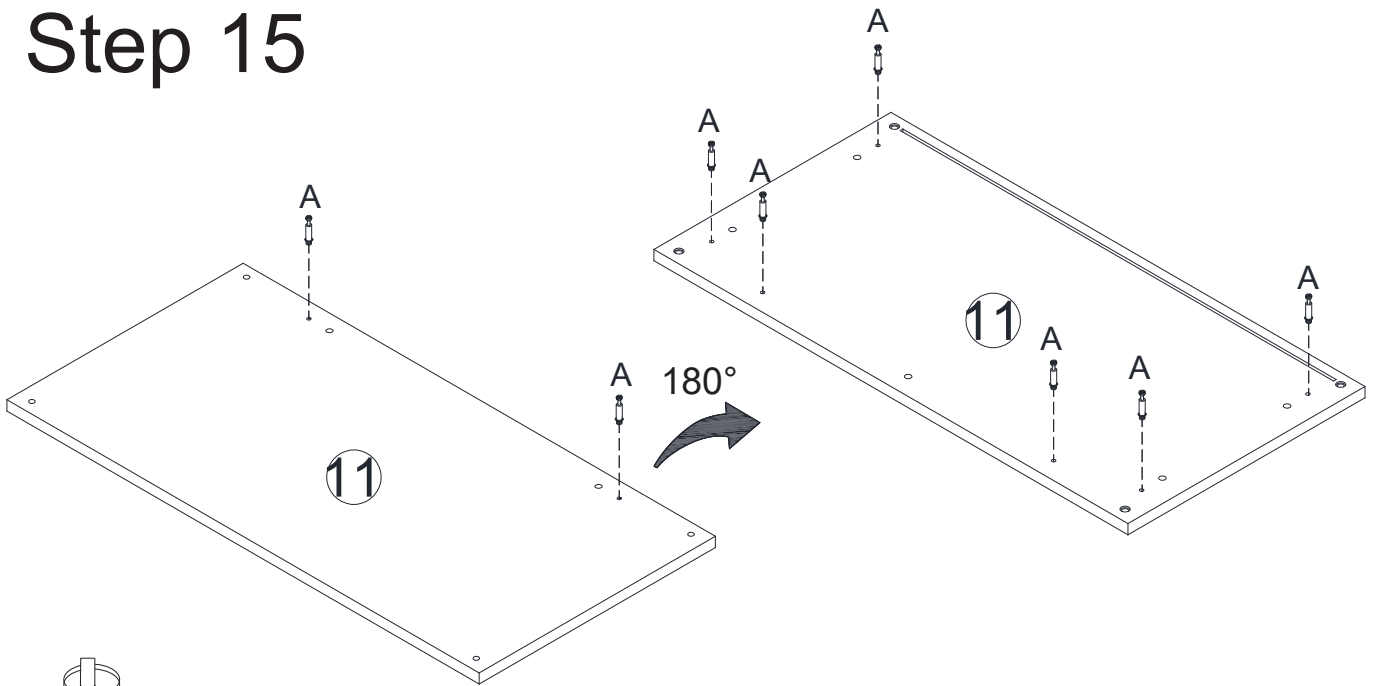

A

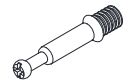

X 8

Step 16

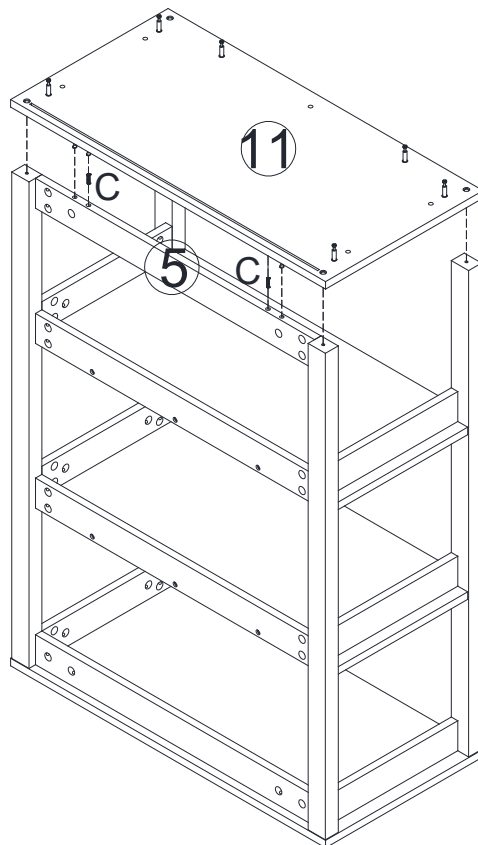

C



X 2

Step 17

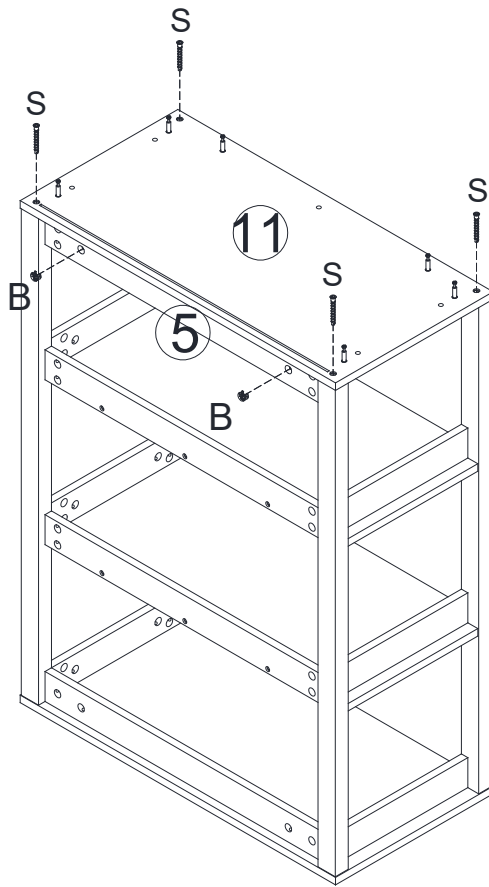
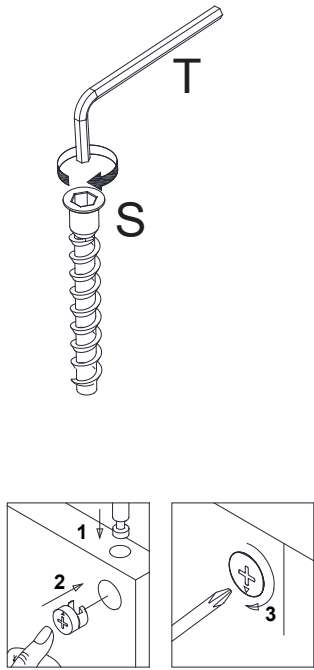

- | | | |
|---|--|-----|
| T | | X 1 |
| B | | X 2 |
| S | | X 4 |

Step 18

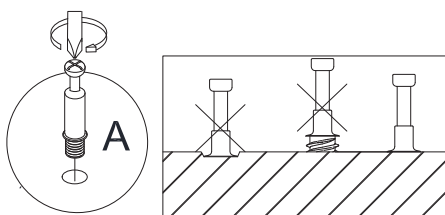
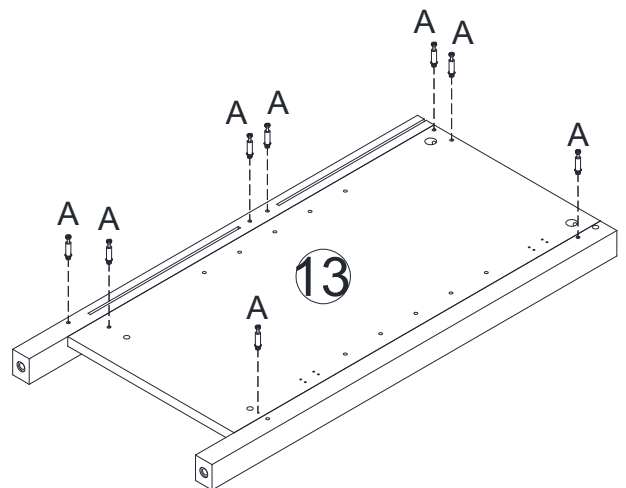
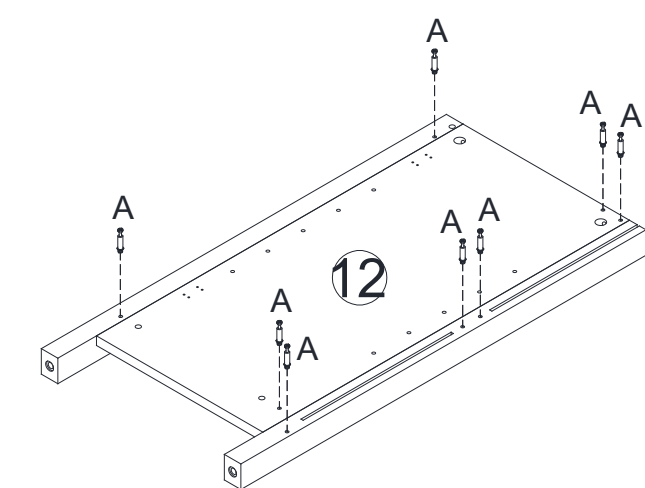

- | | | |
|---|--|------|
| A | | X 16 |
|---|--|------|

Step 19

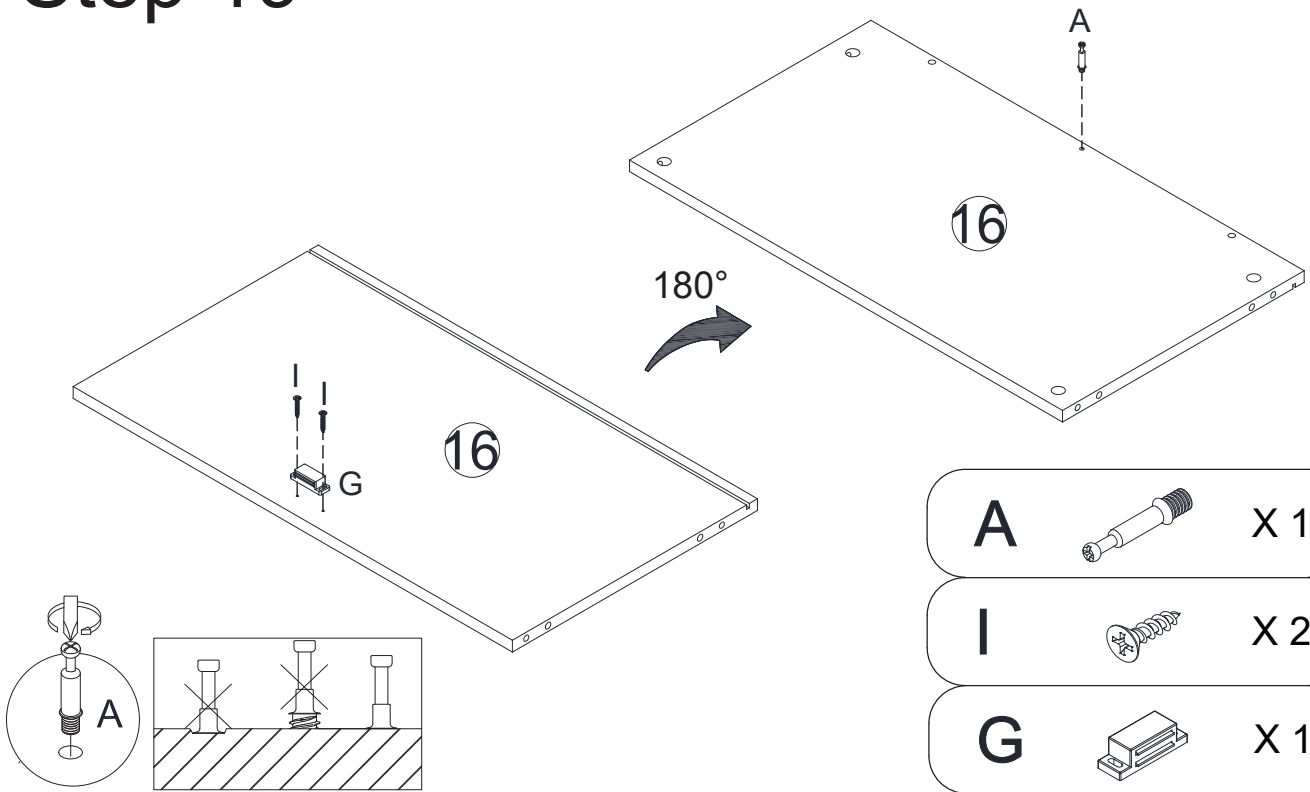

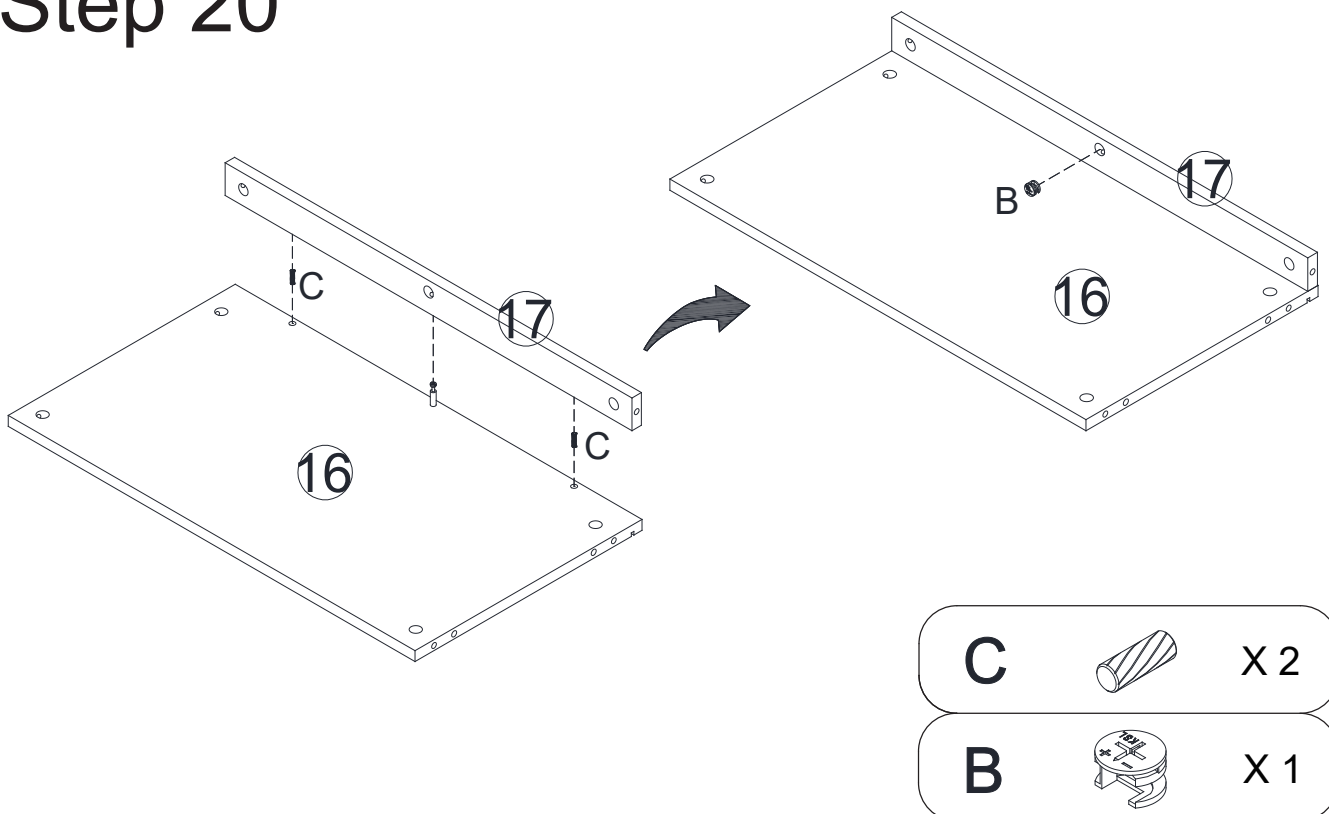

Step 20



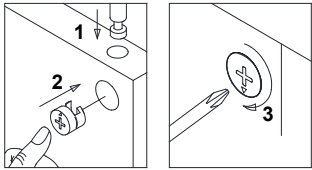
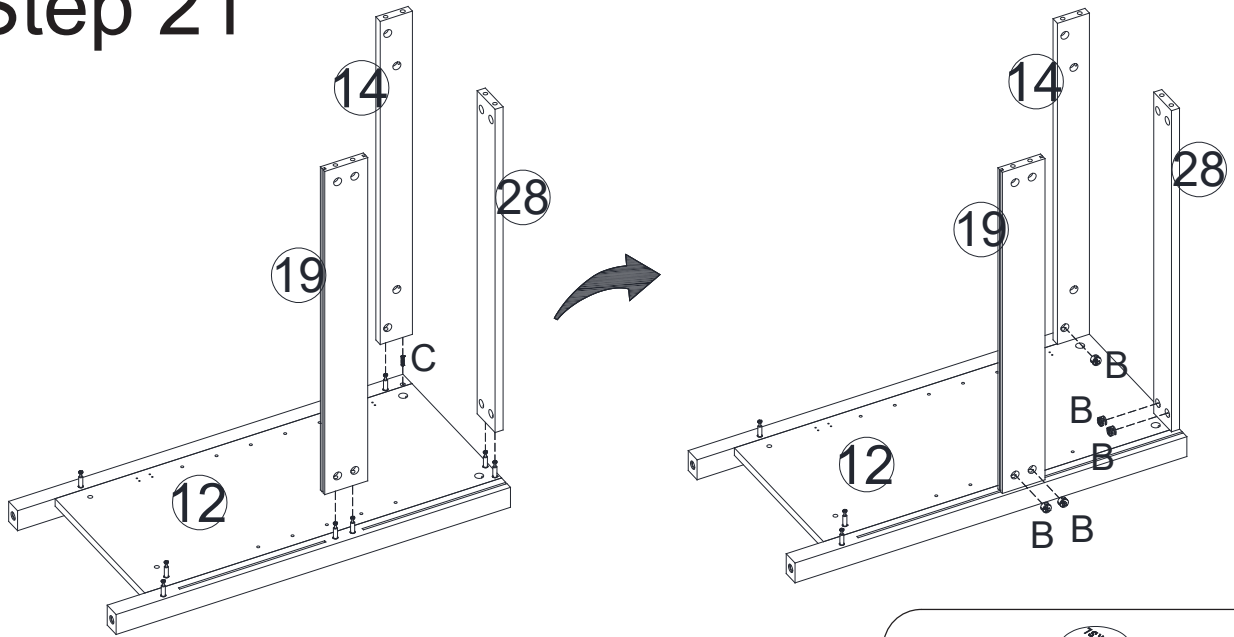

Step 21

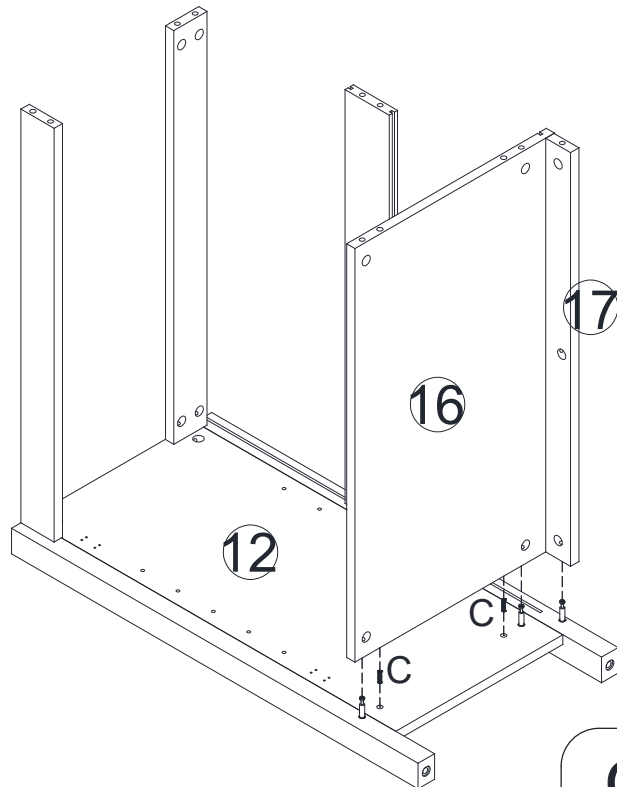

B		X 5
C		X 1

Step 22



C		X 2
----------	---	-----

Step 23

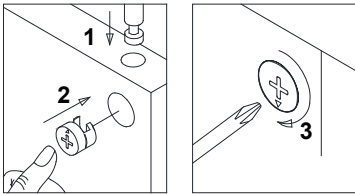
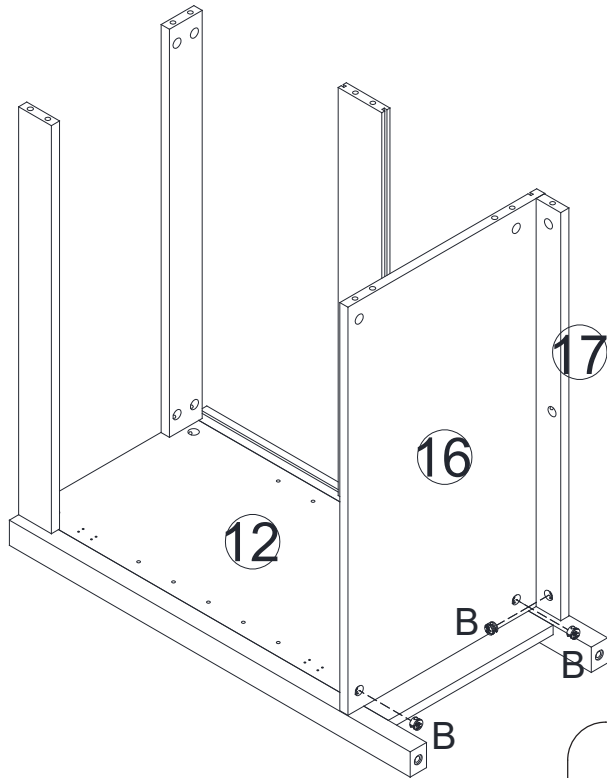

B



X 3

Step 24

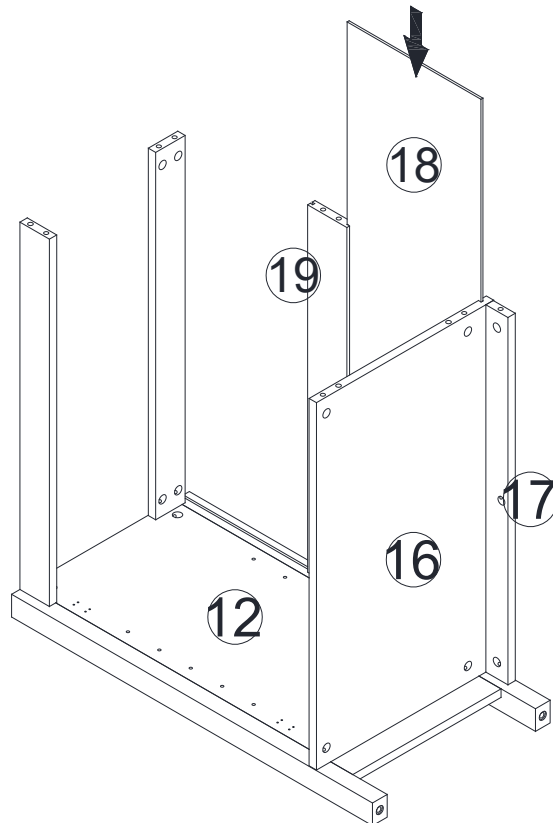

Step 25

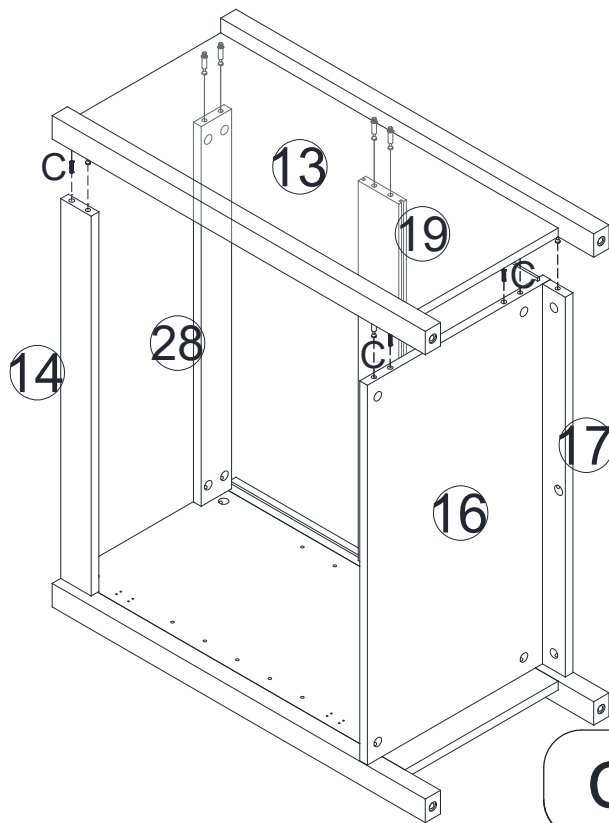

C



X 3

Step 26

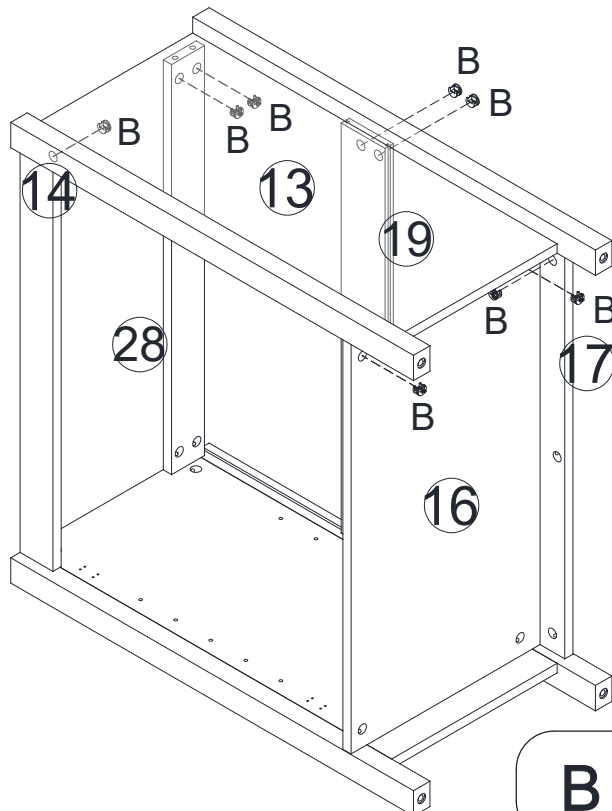

B



X 8

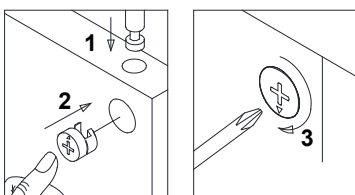

Step 27

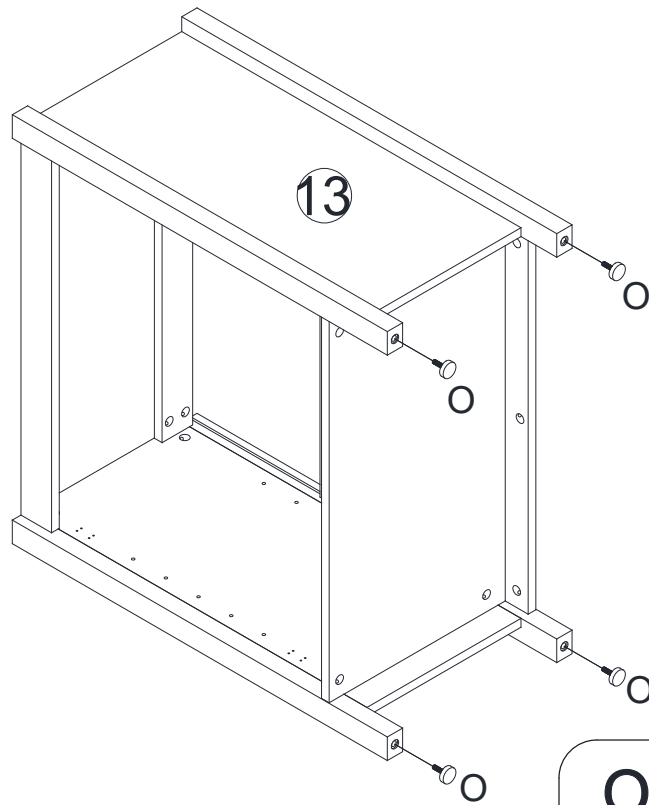

Step 28

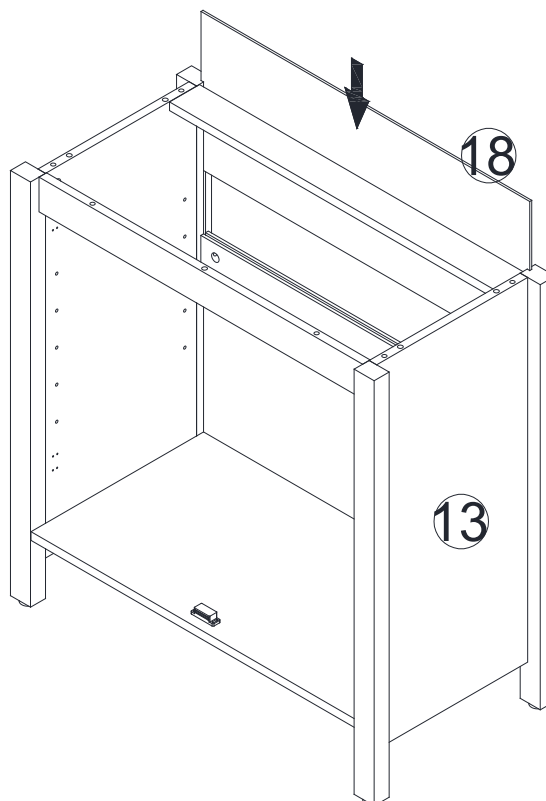

Step 29

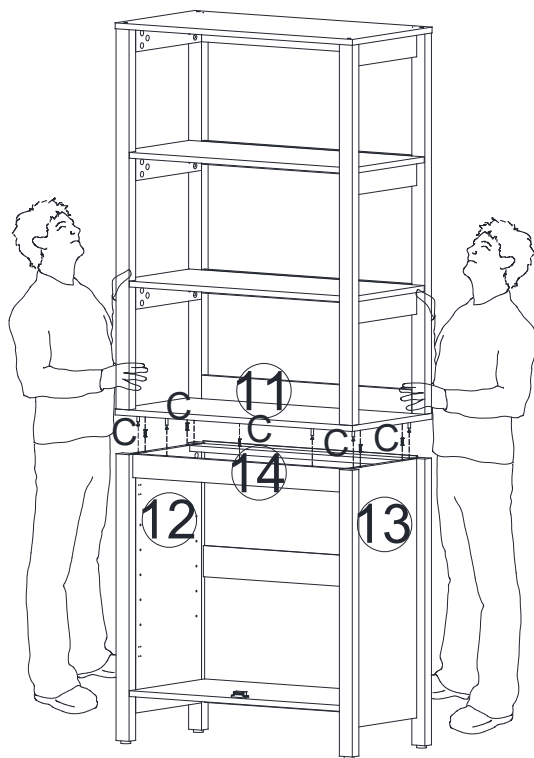

C



X 5

Step 30

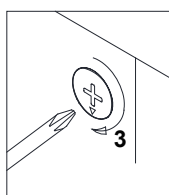
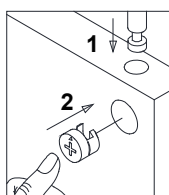
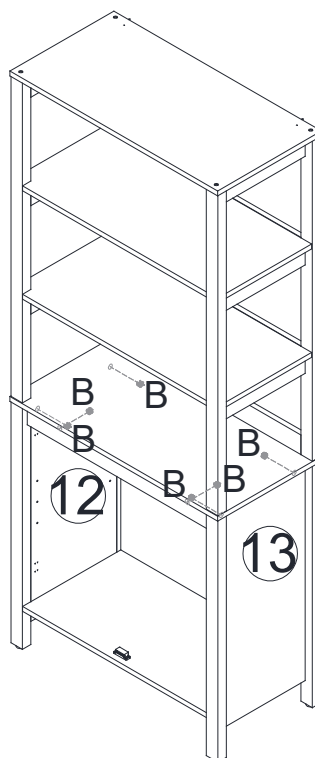

B



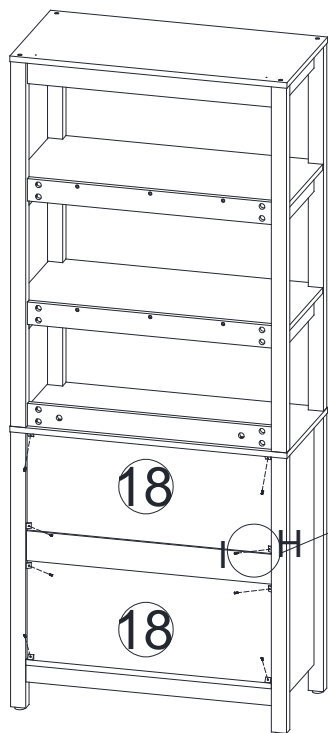

X 6

Step 31



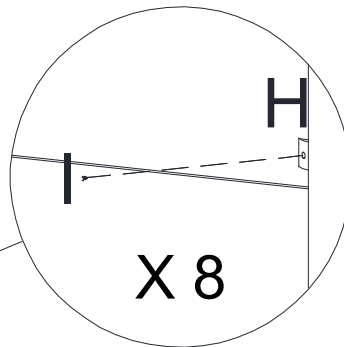

Must Be Installed

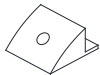

- | | | |
|---|---|-----|
| I |  | X 8 |
| H |  | X 8 |

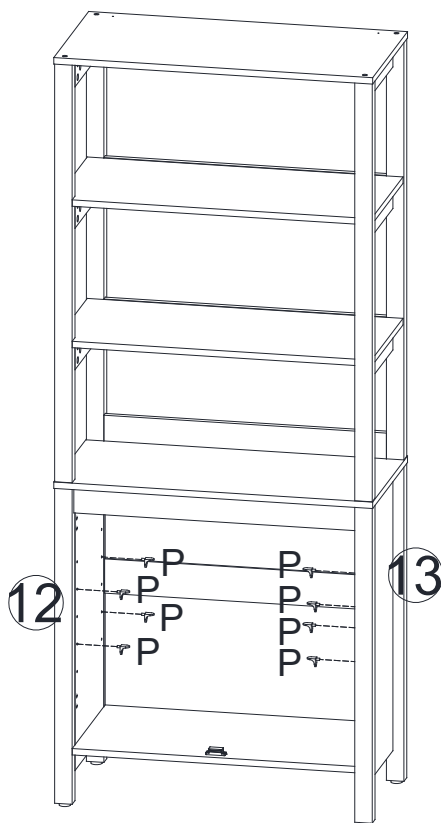
Step 32



- | | | |
|---|---|-----|
| P |  | X 8 |
|---|---|-----|

Step 33

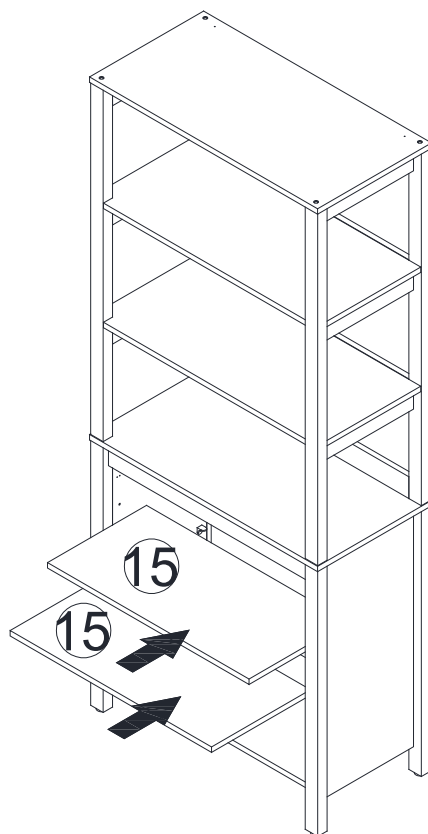

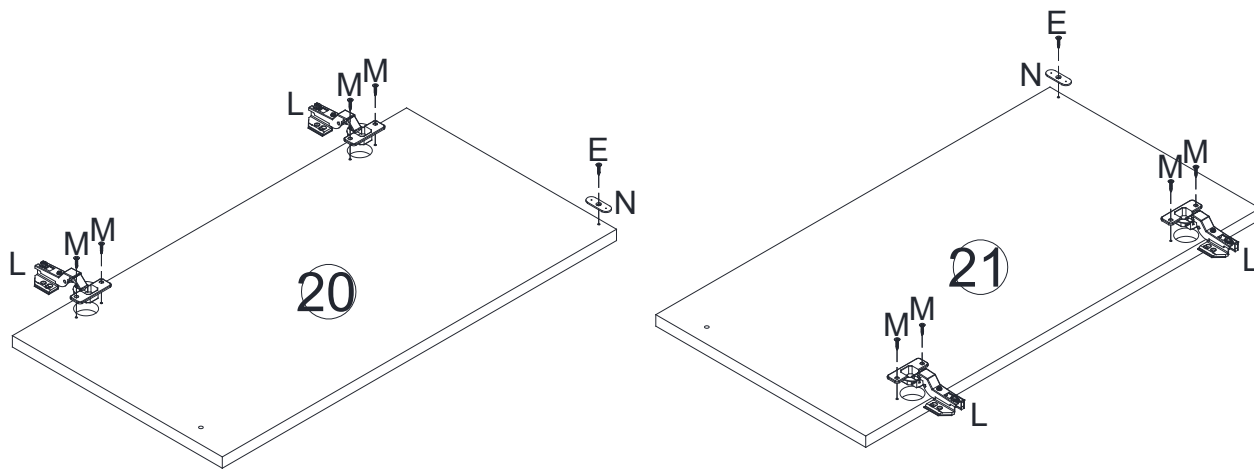

Step 34



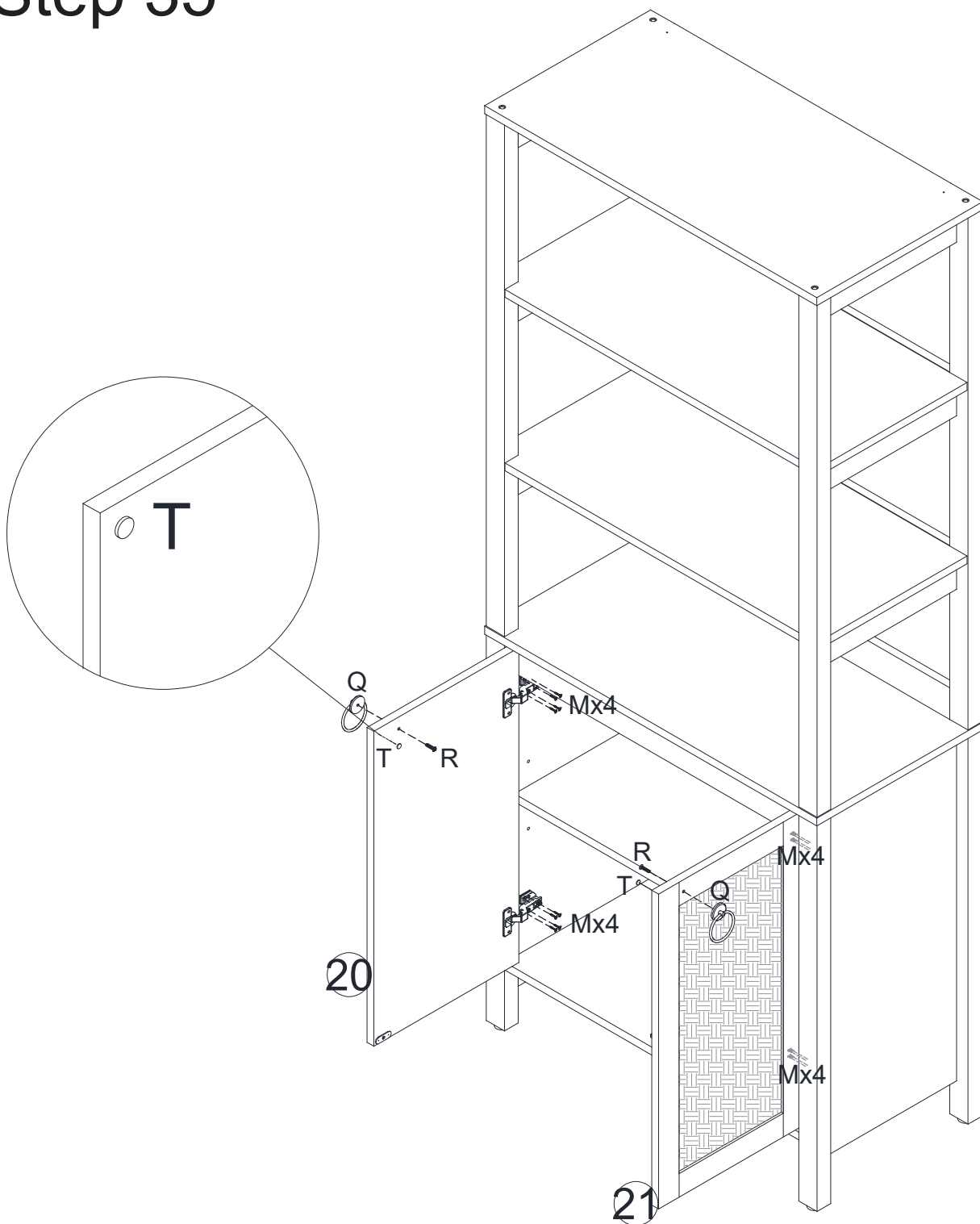

L		X 4	M		X 8
N		X 2	E		X 2

Step 35



M  X 16



R  X 2

T  X 2

Q  X 2

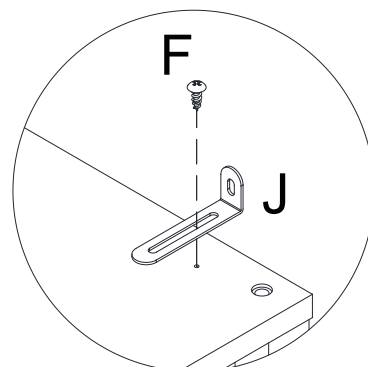
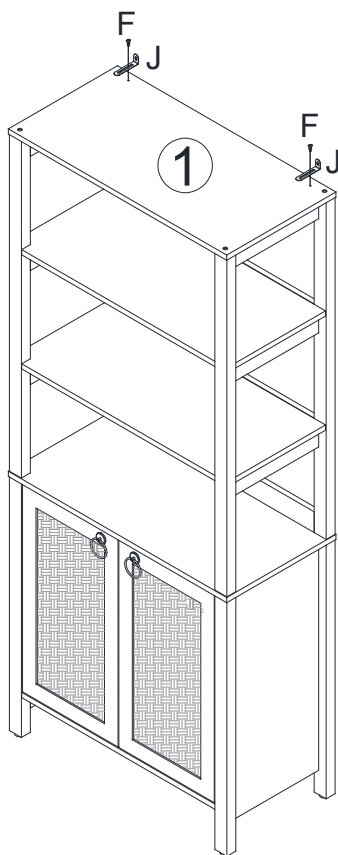

Step 36

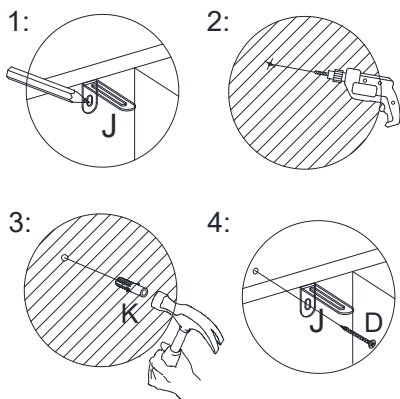
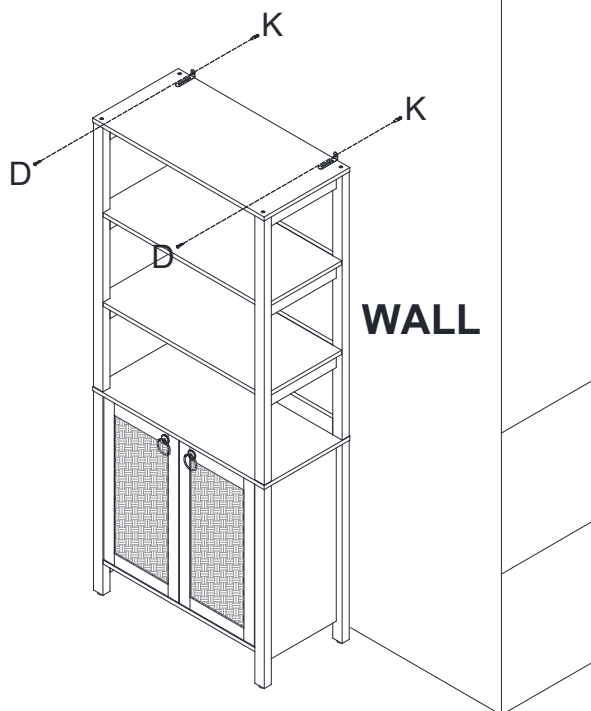

F		X 2
J		X 2

Step 37



K		X 2
D		X 2

Step 38

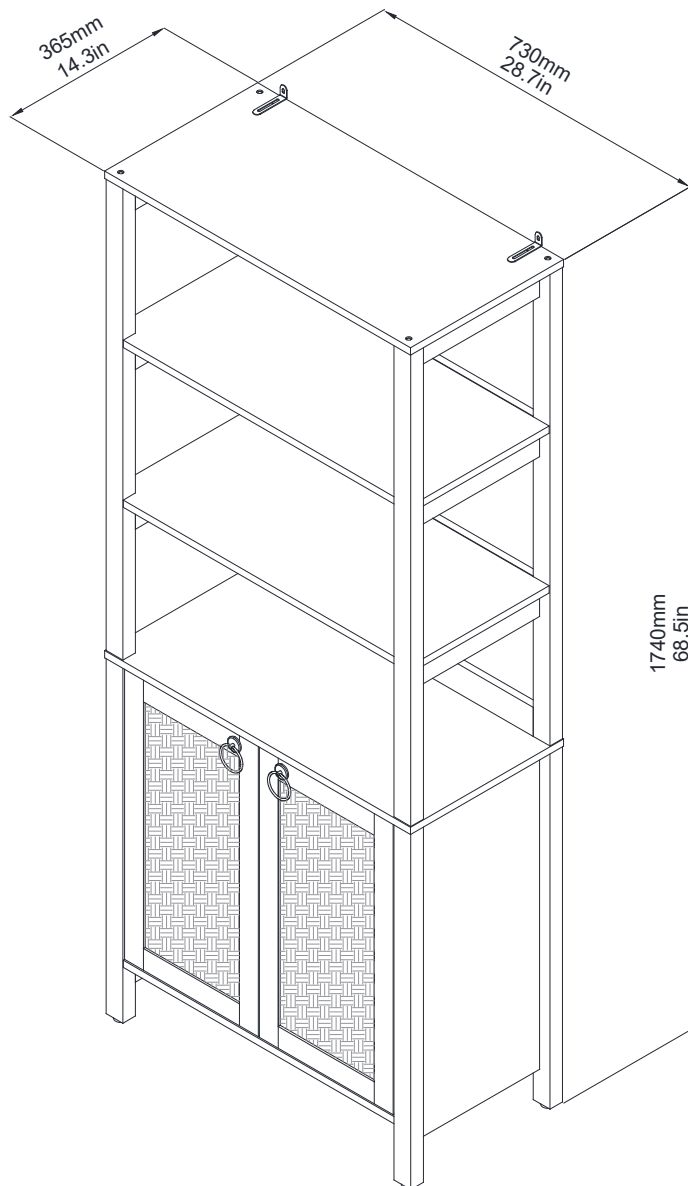

Final assmebly

Cabinet Door Adjustment Instructions

Height adjustment:

- Locate the height adjustment screws on the hinge.
- Use the Phillips screwdriver to either tighten or loosen the screws to raise or lower the cabinet door as desired.

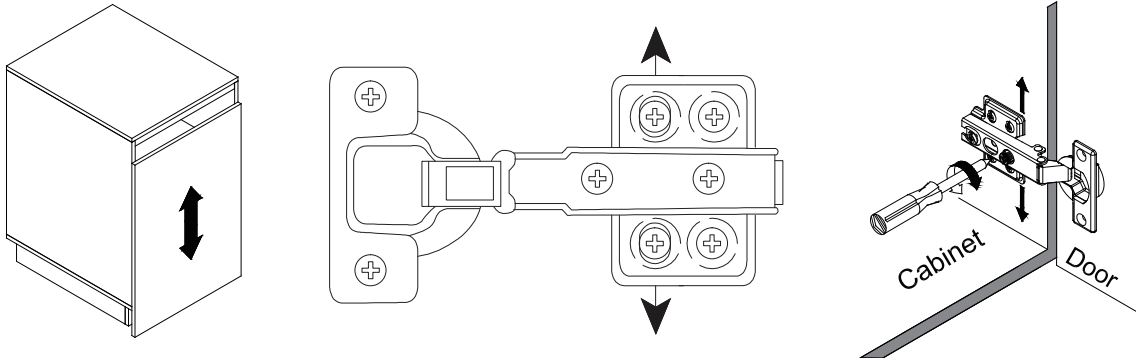

Side-to-side adjustment:

- If the cabinet door needs to be moved closer to or away from the cabinet frame, locate the side-to-side adjustment screws on the hinge.
- Use the Phillips screwdriver to adjust these screws and gradually move the door in the desired direction.

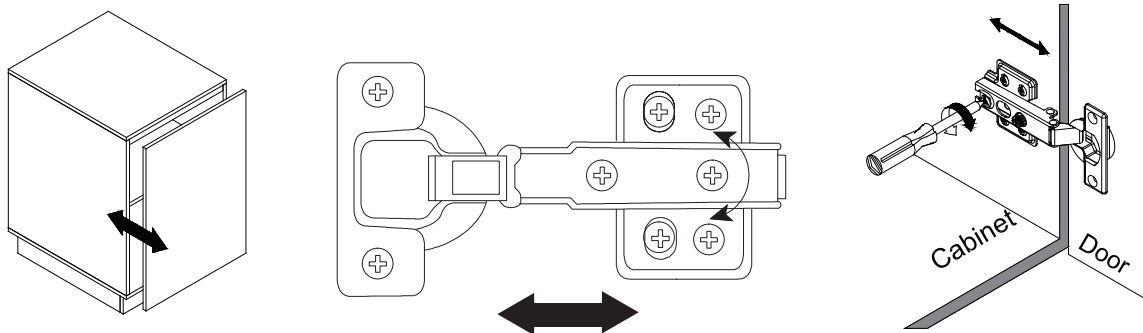

Depth adjustment (if applicable):

- Check if the cabinet door needs to be brought closer to or further away from the cabinet frame.
- For-depth adjustment, locate the depth adjustment screws on the hinge.
- Use the Phillips screwdriver to turn these screws clockwise or counterclockwise accordingly.

