

Wall-mounted Basin Faucet Installation Manual

W-178(ES)

Warranty Duration

All components of this faucet system are covered under a lifetime limited warranty, ensuring they are free from defects in material and workmanship for the original purchaser.

Repair and Replacement

If the product shows defects in material or workmanship under normal use and within the warranty period, we will, at our discretion, either repair the product or provide a replacement at no cost to the original purchaser. Please note that proof of purchase (e.g., an invoice) is required when requesting service. The warranty does not cover damages caused by improper installation, misuse, or modifications.

Exclusions

We shall not be responsible for the following cases:

- Damage to the product caused by improper installation, misuse, unauthorized repair or replacement, or abuse (including damage during shipment).
- Damage to the product caused by improper dismantling after installation.
- Damage resulting from abnormal water pressure or impurities in water pipes, which is not covered under this warranty.
- Rust on the product due to insufficient care and maintenance, which is not covered under this warranty.
- Damage caused by natural disasters such as fire, flood, earthquake, lightning storms, etc., which is not covered under this warranty.

I hope this helps! If you have any further questions or concerns, please let me know.

Having Trouble? Contact us.

 Email: info@faucetsupport.com

 Toll Free: 1-888-969-6880



M2265
SFS-1317B

CONTENT

Basin Faucet Installation Manual ----- (1-7)

CONTENIDO

Manual de instalación del grifo para lavabo ----- (8-14)

◆ Installation and Maintenance Matters

1. Check the accessories list to ensure all parts are included.
2. Do not disassemble the main body by yourself.
3. Connect inlet pipes to supply valves.
4. Make sure inlet pipes and supply valves have no impurities and are cleaned, with no impurities in the pipeline.
5. After installation, check all joints for leakages.
6. Do not leave the basin faucet exposed to a severely corrosive environment.

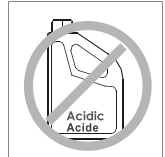
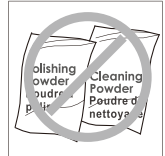
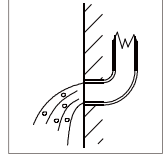
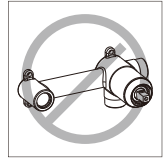

Do's

1. In order to keep the mixer surface bright, please clean the mixer regularly.
2. Rinse the faucet with clean water and wipe it with a soft cotton cloth.
3. Use one of the following cleaners to remove dirt from the surface: a. Mild liquid cleaner. b. Colorless glass cleaner and powder cleaner that do not cause abrasion and can be dissolved completely. c. Polish liquid that does not cause abrasion.

Don'ts

1. Avoid using cleaning powder, harsh cleaning chemicals, brushes and coarse cloth to prevent scratching and friction.
2. Do not use acid cleaners to clean the faucet as they may cause surface corrosion of the faucet. If the faucet is exposed to harmful acid substances, please rinse it immediately with water.

Tools Needed:

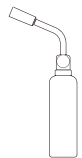
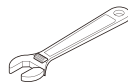
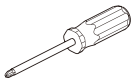

◆ **Concealed Hot and Cold Basin Faucet Accessories List**

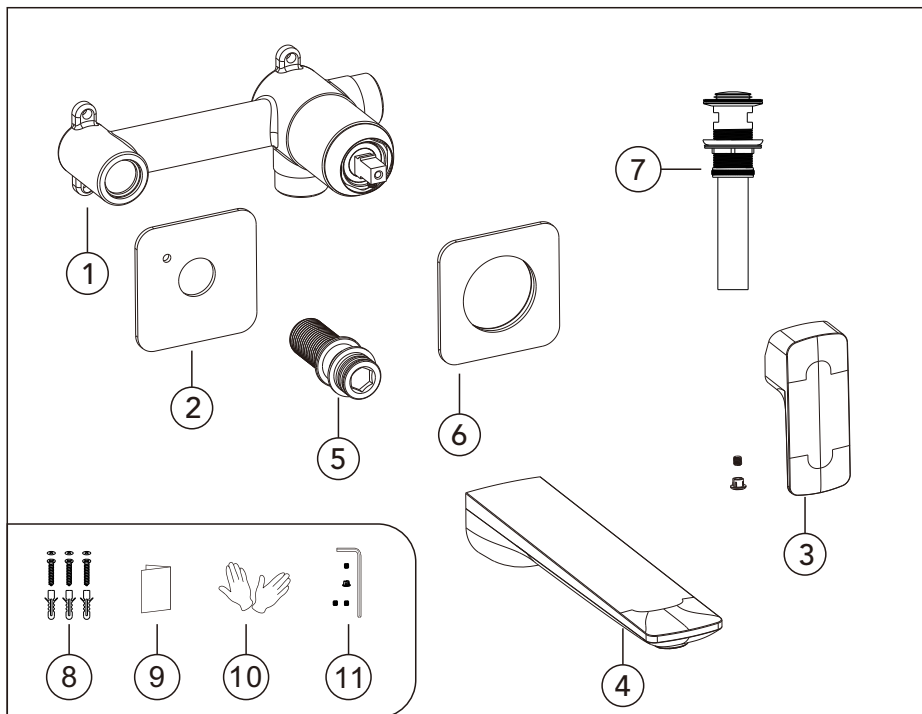

No.	Part Name	Qty	No.	Part Name	Qty
1	Rough-in Valve	1	7	Drain	1
2	Flange	1	8	Main Body Spare Parts	1set
3	Handle	1	9	Instruction Manual	1
4	Spout	1	10	Gloves	1pair
5	Outlet Connector	1	11	Screw Parts	1set
6	Flange	1	12		

◆ Water Circuit Diagram of Basin Faucet

Unit: mm/inch

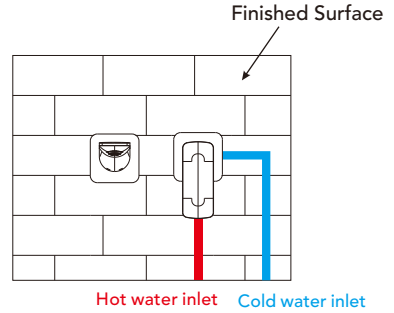
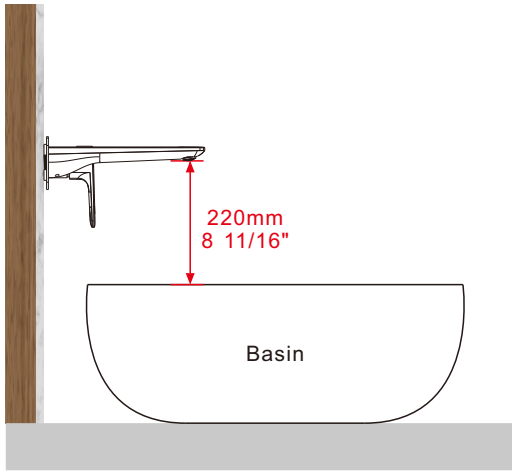

◆ Embedding depth of the Rough-in Valve

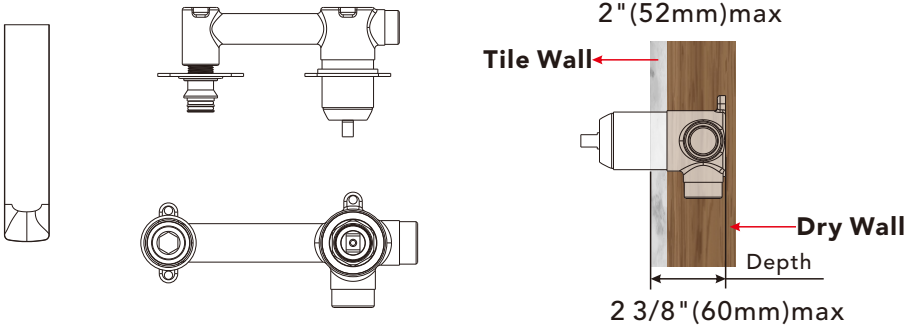

Notice: 1. The installation depth of rough-in valve should be no less than 2" (52mm) and no more than 2 3/8" (60mm), including the thickness of tile. Otherwise, the deck plate cannot be installed.

◆ Installation of the Rough-in Valve (concrete wall)

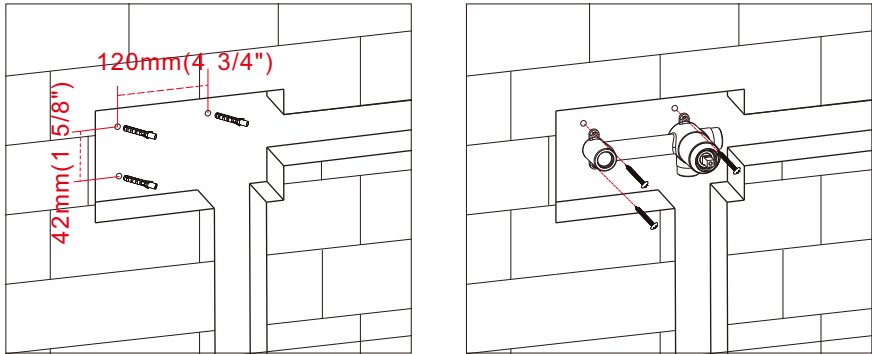

- Step 1: Measure and mark the installation points based on the dimensions of the rough-in valve. Drill holes into the concrete wall at the marked locations and insert the wall anchors.
- Step 2: Secure the rough-in valve to the wall using screws inserted into the wall anchors. Connect the hot and cold water inlet pipes to their respective inlets.
- Step 3: Perform a pressure test to check for leaks at all connections. Ensure there are no leaks before proceeding to the next step.
- Step 4: Once the pressure test is complete and all connections are confirmed to be secure, seal the rough-in valve with concrete.

◆ Installation of the Rough-in Valve (wood wall)

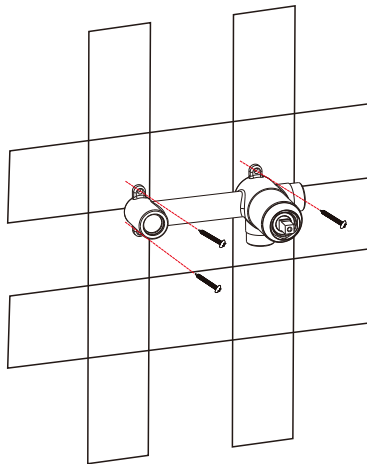

- 1: Secure the rough-in valve directly to the wooden structure using screws.

◆ Installation of the Basin Faucet

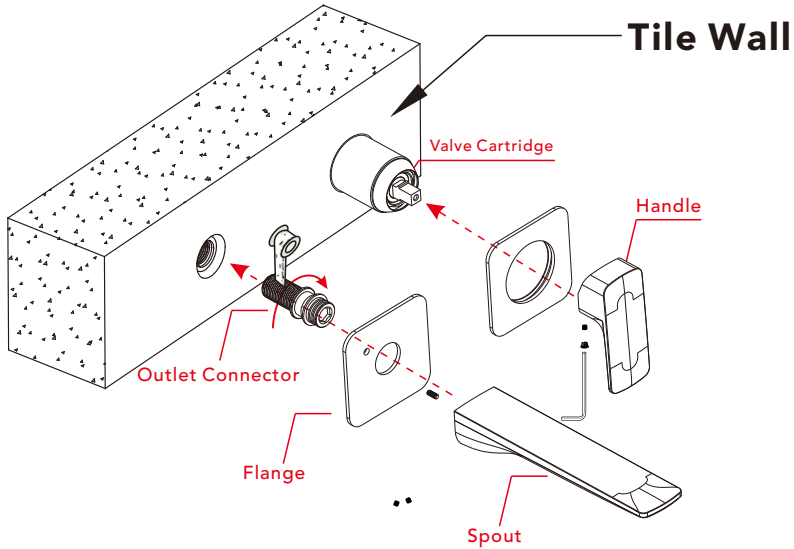

1. After wrapping plumber's tape around the outlet connector, screw it clockwise into the rough-in valve (concealed body) as shown in the figure.
 2. Pass the spout through the opening in the flange, install it onto the outlet connector, and tighten the screw underneath. Then push the flange back until it sits flush against the tile.
 3. Install the handle and flange onto the valve cartridge and tighten the set screw.
-

◆ Drain Installation

Step1

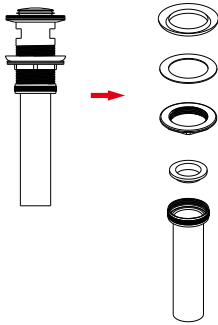

- Disassemble the drain starting from the bottom part. As shown in the left image, remove all components.

Step2

- Insert the top of the drain into the basin drain hole, and from the bottom upwards, sequentially fit the rubber gasket, washer, and fixing brass sleeve. Rotate the brass sleeve to the right until it is tight, but do not over-tighten to avoid damaging the basin or the drain.

- Finally, continue to rotate and tighten the lower part of the drain components downward to complete the drain installation.

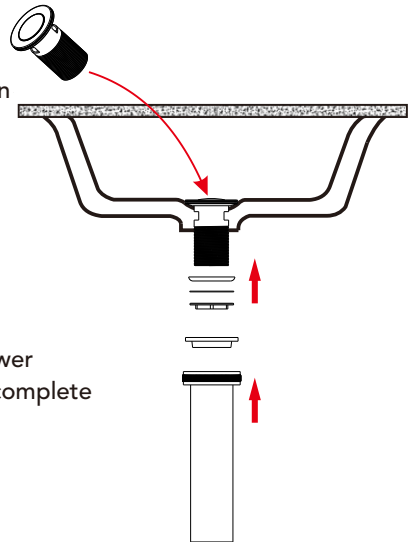

◆ Drain Installation

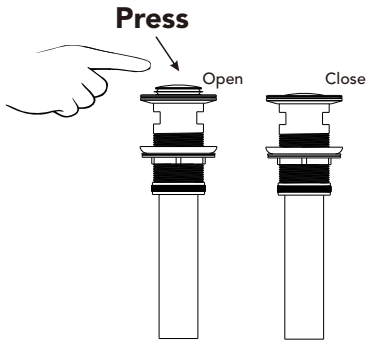

Press the pop-up button on top of the drain to open and close the drain outlet.



Notice:

1. **Sealing Test:** Turn on the faucet and let the water run for a few minutes. Observe the drain and the drainage pipe connections for any leaks. If you find any leaks, readjust the tightness of the gasket and nuts.
2. **Drainage Speed Test:** Ensure that the water drains smoothly without any blockages or slow drainage issues.
3. **Choose the Right Drain:** Different basins may require different sizes and types of drains. Make sure the drain you purchase matches your basin.

◆ Instalación y cuestiones de mantenimiento

1. Verifique la lista de accesorios para asegurarse de que todas las piezas estén incluidas.
2. No desmonte el cuerpo principal por sí mismo.
3. Conecte las tuberías de entrada a las válvulas de suministro.
4. Asegúrese de que las tuberías de entrada y las válvulas de suministro no tengan impurezas y estén limpias, sin impurezas en la tubería.
5. Después de la instalación, verifique todas las uniones para detectar fugas.
6. No deje el grifo de lavabo expuesto a un ambiente altamente corrosivo.

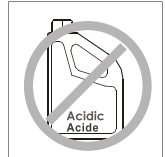
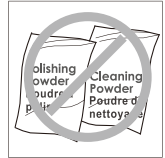
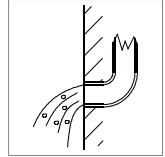
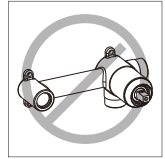

Hacer

1. En para mantener la superficie de la batidora brillante, limpie el mezclador regularmente.
2. Inse el grifo con agua limpia y límpielo con un suave ropa de algodón.
3. Utilice uno de los siguientes limpiadores para eliminar la suciedad de la superficie: a. Limpiador líquido suave. b. Limpiador de vidrio incoloro y limpiador en polvo que no causen abrasión y que se puedan disolver completamente. c. Líquido pulidor que no cause abrasión.

No es decir

1. Valte con polvo de limpieza, productos químicos de limpieza duros, cepillos y tela gruesa para evitar rascar y fricción.
2. No use limpiadores de ácidos para limpiar el grifo, ya que pueden causar corrosión superficial del grifo. Si el grifo está expuesto a sustancias ácidas dañinas, enjuague inmediatamente con agua.

HERRAMIENTAS NECESARIAS:

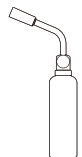
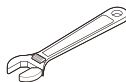
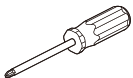

◆ **Grifo de lavabo empotrado de agua caliente y fría**
Lista de accesorios

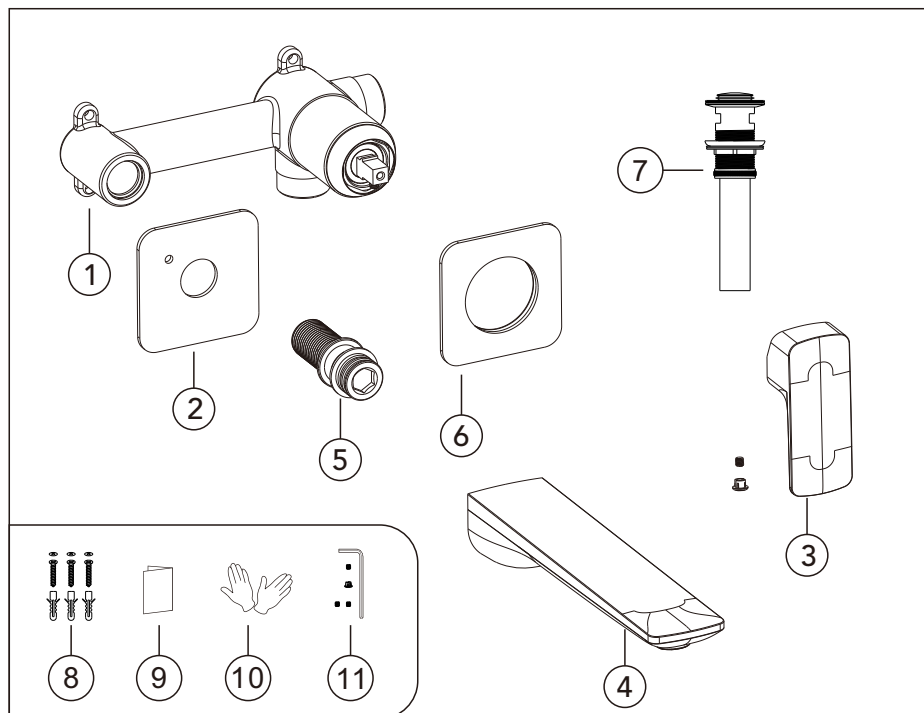

N.º	Nombre de la pieza	Cant	N.º	Nombre de la pieza	Cant
1	Válvula de Preinstalación	1	7	Desagüe	1
2	Brida	1	8	Repuestos del cuerpo principal	1 juego
3	Brida de la manija	1	9	Manual de instrucciones	1
4	Caño de bañera	1	10	Guantes	1 par
5	Brida del surtidor	1	11	Piezas de la manija	1 juego
6	Casquillo de fijación	1	12		

◆ Diagrama del circuito de agua del grifo de lavabo

Unidad: mm/pulgada

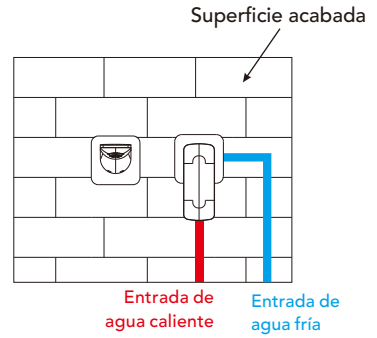
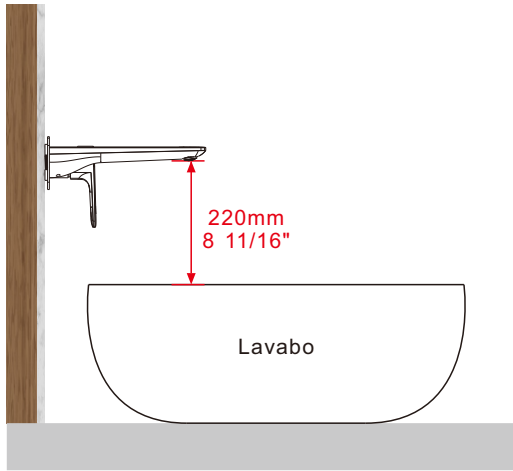

◆ Profundidad de empotramiento de la válvula de instalación

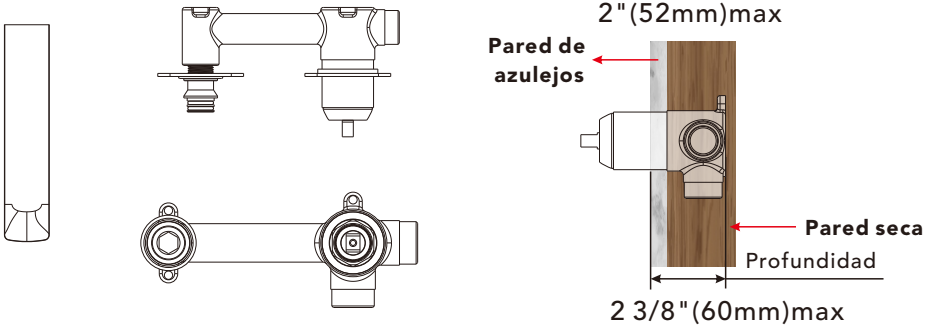

Aviso: 1. La profundidad de instalación de la válvula empotrada debe ser no menor de 2" (52 mm) y no mayor de 2 3/8" (60 mm), incluido el espesor del azulejo. De lo contrario, no se podrá instalar la placa embellecedora.

◆ Instalación de la válvula de empotramiento (pared de concreto)

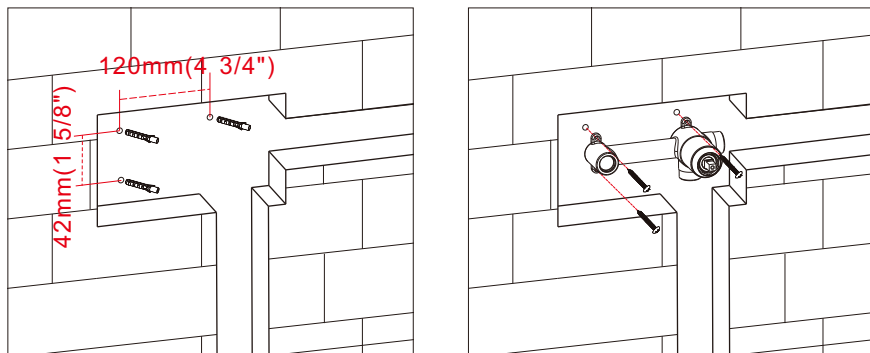

- Paso 1: Mida y marque los puntos de instalación según las dimensiones de la válvula de preinstalación. Perfore agujeros en la pared de concreto en las ubicaciones marcadas e inserte los anclajes de pared.
- Paso 2: Fije la válvula de preinstalación a la pared utilizando tornillos insertados en los anclajes de pared. Conecte las tuberías de entrada de agua caliente y fría a sus respectivas entradas.
- Paso 3: Realice una prueba de presión para verificar si hay fugas en todas las conexiones. Asegúrese de que no haya fugas antes de proceder al siguiente paso.
- Paso 4: Una vez completada la prueba de presión y confirmadas todas las conexiones como seguras, selle la válvula de preinstalación con concreto.

◆ Instalación de la Válvula de Preinstalación (pared de madera)

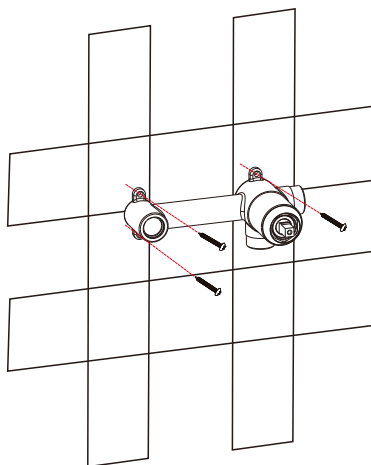

- 1: Fije la válvula de preinstalación directamente a la estructura de madera utilizando tornillos.

◆ Instalación del grifo de lavabo

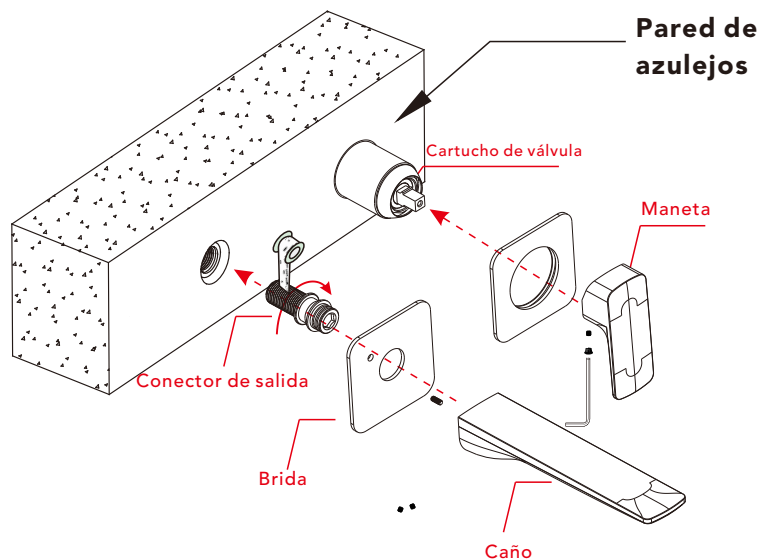

1. Tras envolver el conector de salida con cinta de teflón (cinta PTFE), enrósquelo en sentido horario en la válvula empotrada (cuerpo oculto) tal como se muestra en la figura.
 2. Pase el caño por la abertura de la brida, instálelo en el conector de salida y apriete el tornillo situado en la parte inferior. Luego empuje la brida hacia atrás hasta que quede al ras contra el azulejo.
 3. Instale la maneta y la brida en el cartucho de la válvula y apriete el tornillo prisionero.
-

◆ Instalación del desagüe

Paso 1

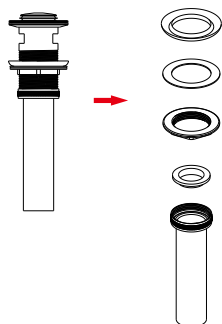

- Desmonte el desagüe comenzando por la parte inferior. Como se muestra en la imagen de la izquierda, retire todos los componentes.

Paso 2

- Inserte la parte superior del desagüe en el orificio de drenaje del lavabo y, desde la parte inferior hacia arriba, coloque secuencialmente la junta de goma, la arandela y la manga de fijación de latón. Gire la manga de latón hacia la derecha hasta que quede ajustada, pero no apriete en exceso para evitar dañar el lavabo o el desagüe.
- Finalmente, continúe girando y apretando hacia abajo la parte inferior de los componentes del desagüe para completar la instalación.

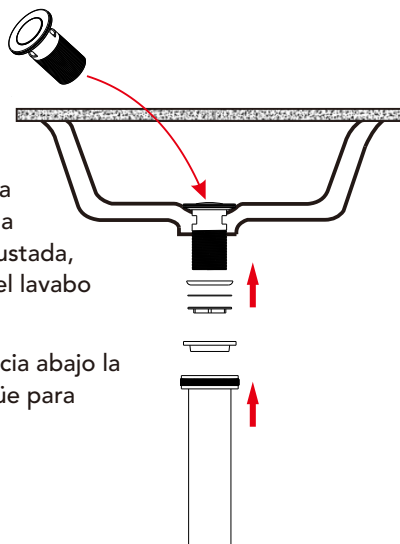

◆ Instalación del desagüe

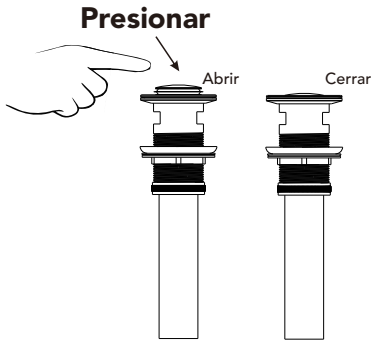

Presione el botón emergente en la parte superior del desagüe para abrir y cerrar la salida de agua.



Aviso:

1. Prueba de sellado: Abra el grifo y deje correr el agua durante unos minutos. Observe el desagüe y las conexiones de la tubería de drenaje para detectar posibles fugas. Si encuentra alguna fuga, reajuste la junta y las tuercas hasta lograr un sellado adecuado.
2. Prueba de velocidad de drenaje: Asegúrese de que el agua drene sin problemas, sin bloqueos ni problemas de drenaje lento.
3. Elija el desagüe adecuado: Diferentes lavabos pueden requerir distintos tamaños y tipos de desagües. Asegúrese de que el desagüe que compre sea compatible con su lavabo.