

# ASSEMBLY INSTRUCTIONS & PARTS IDENTIFICATION LADDERBACK STOOL

Thank you for purchasing this quality product. Be sure to check all packing material carefully for small parts that may have come loose inside the carton during shipment

Hardware kit			
No		Description	Q'Ty
A		Hexa Nut 5/16"	4 pcs
B		Lock Washer 5/16"	11 pcs
C		Flat Washer 5/16"	11 pcs
D		Long Bolt 1/4" x 3"	4 pcs
E		Short Bolt 1/4" x 1.5"	3 pcs
F		Allen Key	1 pc
G		Key Wrench	1 pc
H		Screw Ø4 x 38mm	6 pcs

Key Parts			
No	Code	Description	Q'Ty
1	A	Chair Back	1 pc
2	B	Complete Seat	1 pc
3	C	Right Facing Front Leg	1 pc
4	D	Left Facing Front Leg	1 pc
5	E	Right Facing Side Stretcher	1 pc
6	F	Left Facing Side Stretcher	1 pc
7	G	Front Stretcher	1 pc
8	H	Floor glide	4 pcs

FABRIC CARE : CLEANING CODE "S"

Clean only with dry cleaning solvent. Do not saturate. Do not use water.  
Pile fabrics may require brushing to restore appearance.

FABRIC CONTENT: 55% Cotton, 45% Linen

## STEP 1

- Carefully lay Chair Back flat on a smooth flat surface to prevent scratches.
- Attach Complete Seat to Chair Back by inserting a Flat Washer (C), Lock Washer (B) with Short Bolt (E) into each of the hole on the back rail of the seat, and Long Bolt (D) into each of 2 holes in the Complete Seat corners. (See Detail A & B).
- Tighten screws with provided Allen Key (F) by turning clockwise until secure

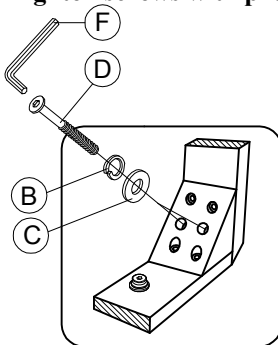

DETAIL B

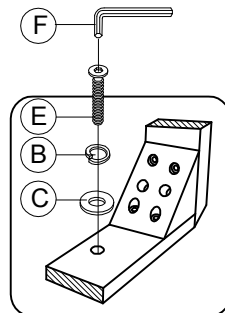

DETAIL A

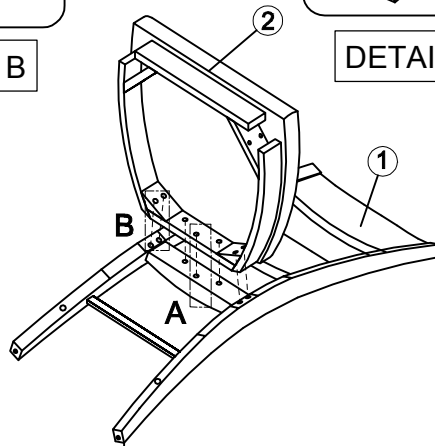

DETAIL D

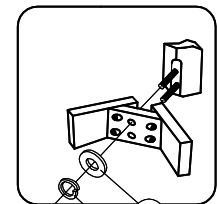
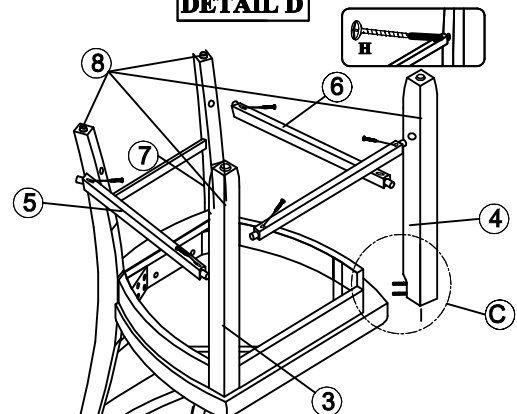

DETAIL C

## STEP 2

- Carefully turn chair upside down and insert the right stretcher into the back leg and then attach the right front leg to corner block and the right stretcher.
- Insert the center stretcher into the right stretcher
- Insert the left stretcher to back leg and the front stretcher and then attach the left front leg to corner block and the left stretcher.
- Place Flat Washer (C), Lock Washer (B) and Nut (A) on for each bolt, using provided Key Wrench (G).
- Tighten the Nuts at this stage until all the parts are in position (See Detail C).
- Fasten stretchers with Wood Screw(H) on either and using Phillips head screw driver. (not provided).(See Detail D)
- Be sure to tighten all screws and nuts prior to using Chair.

MADE IN VIET NAM