

Assembly Instructions

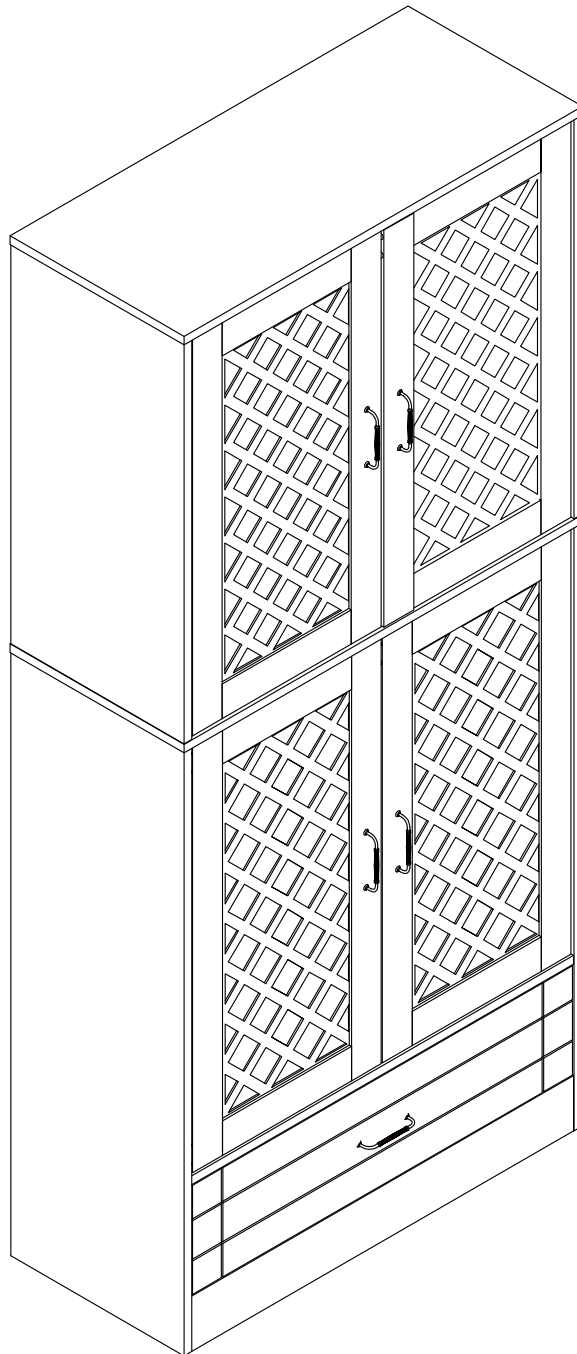

Kitchen Pantry

Model
HOGA-JW0955

Contact Us

We're here to help you.



Your satisfaction is our top priority. If you encounter any issues with this product, such as missing or damaged parts, we're here to help. Please retain the original packaging and take photos of the packaging and the product, then contact us as soon as possible.

Warm Tips

1. Carefully read these instructions and keep them for future reference.
2. Check the parts list and confirm everything's there before starting assembly.
3. When assembling, put all parts on a soft, smooth surface like a carpet to avoid scratches.
4. Don't fully tighten screws until all parts are confirmed in place to avoid misalignment.

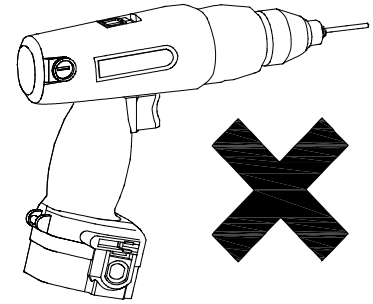
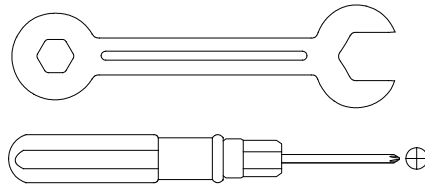
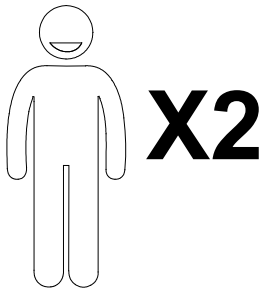

We recommend using hand tools for assembly.

If an electric screwdriver is used, reduce power and torque to avoid damage to the product.

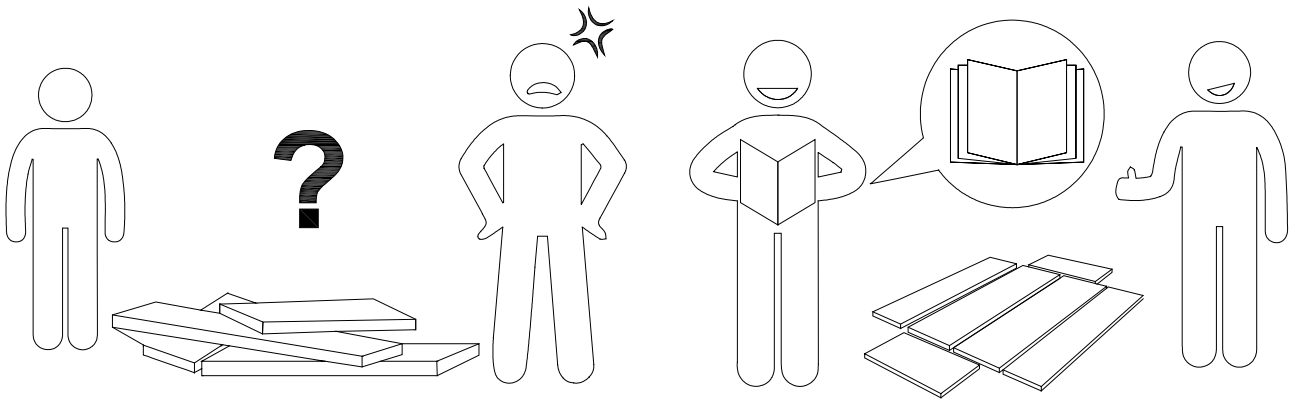

Install the Anti-Tip Straps

Using the anti-tip straps can reduce the risk of tipping over, but can not eliminate it.

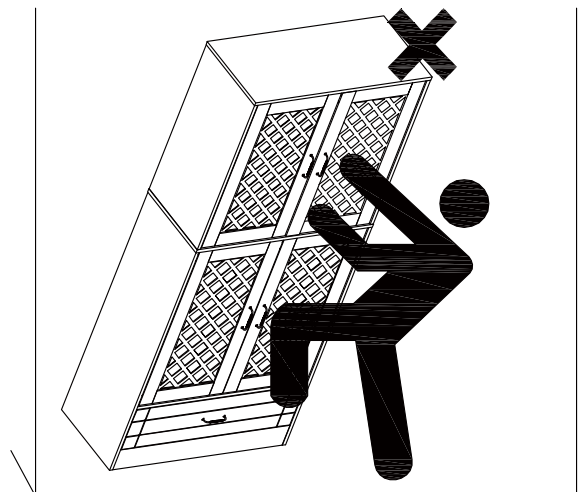
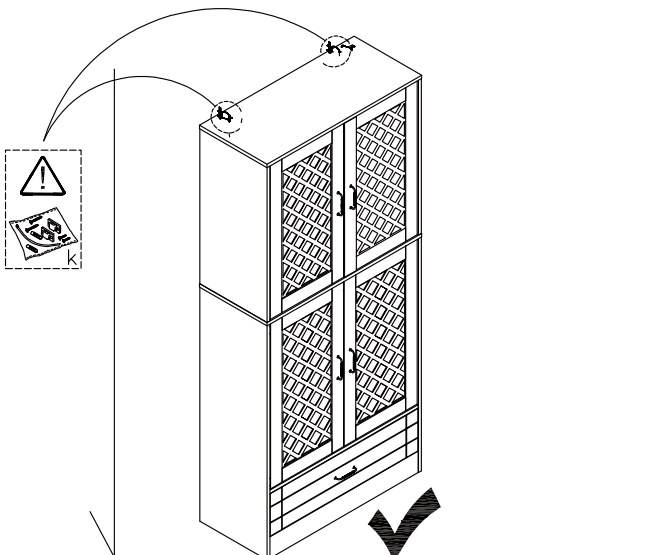

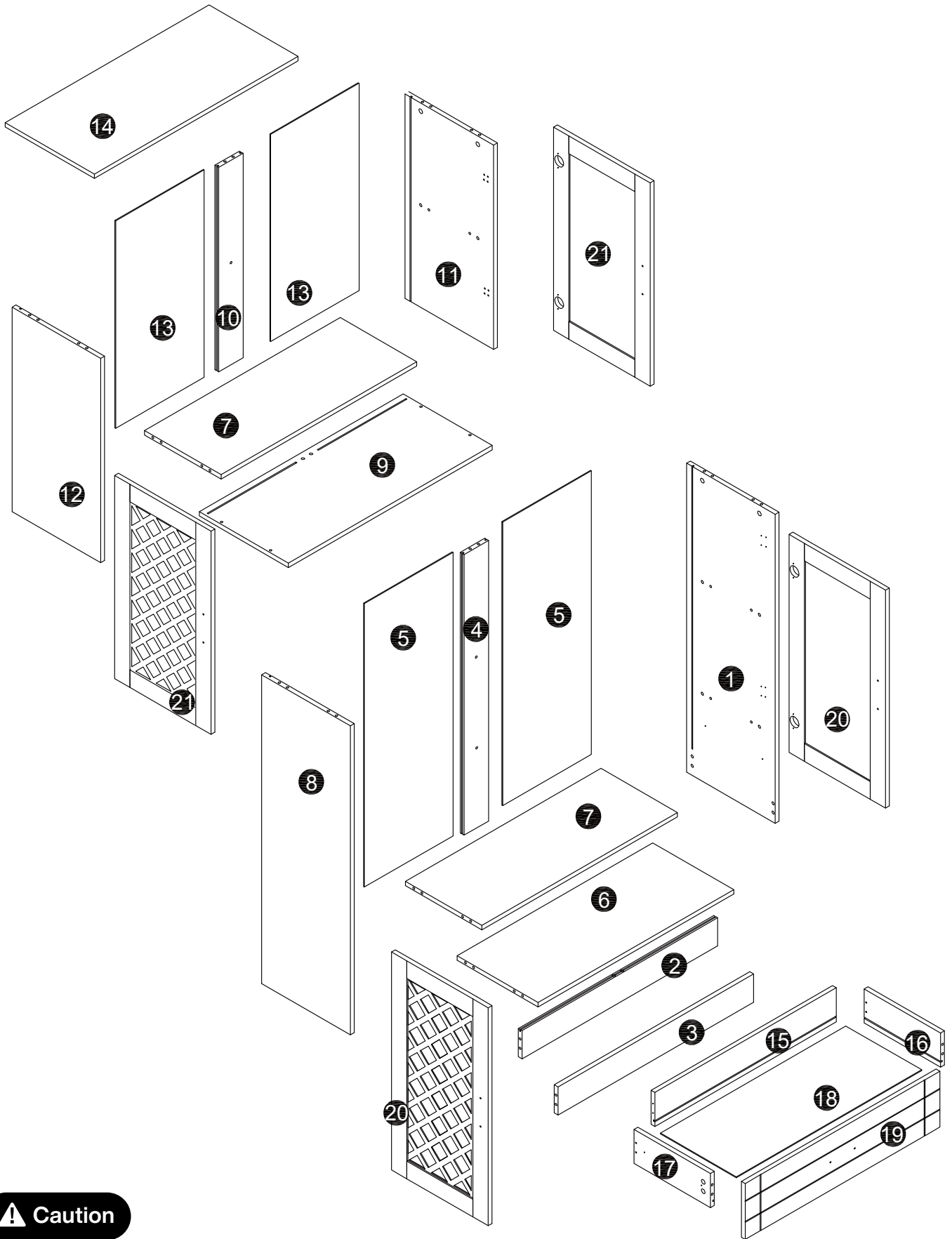



⚠ Caution

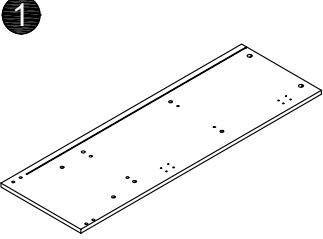
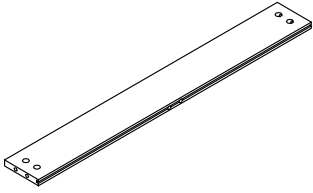
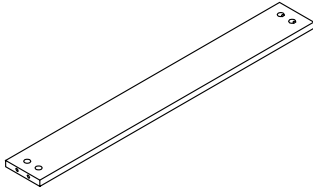
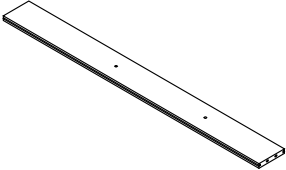
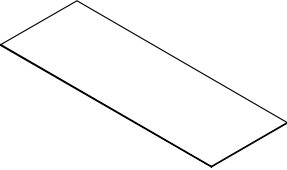
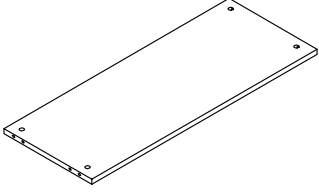
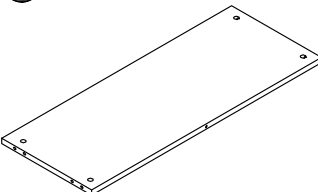
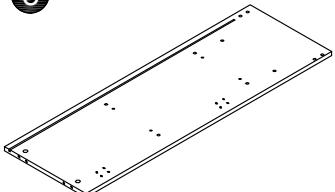
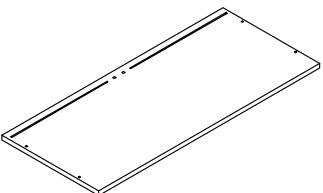
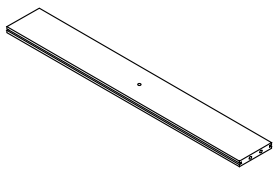
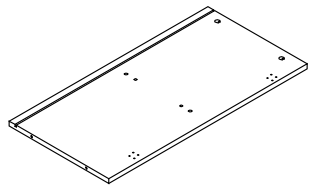
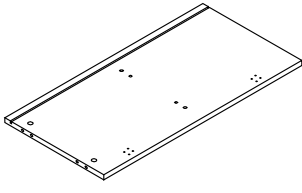
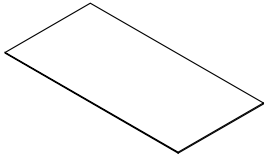
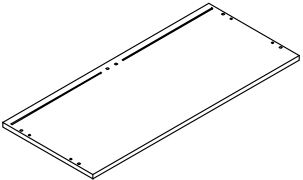
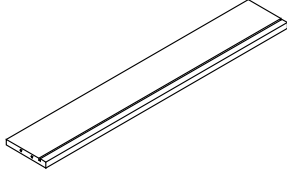
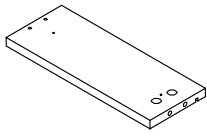
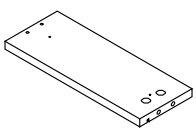
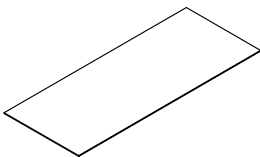
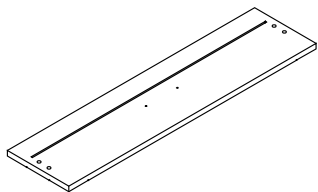
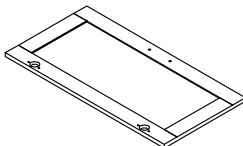
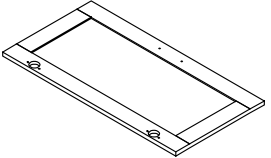

Make sure all parts are included. Most board parts are labeled or stamped on the raw edge. Contact us for a free replacement if you encounter any damaged or missing parts.

Parts List

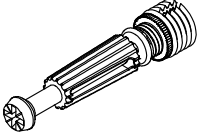
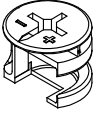
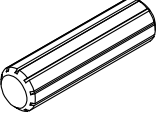
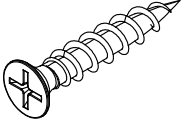
 <p>1 pc</p>	 <p>1 pc</p>	 <p>1 pc</p>	 <p>1 pc</p>
 <p>2 pcs</p>	 <p>1 pc</p>	 <p>2 pcs</p>	 <p>1 pc</p>
 <p>1 pc</p>	 <p>1 pc</p>	 <p>1 pc</p>	 <p>1 pc</p>
 <p>2 pcs</p>	 <p>1 pc</p>	 <p>1 pc</p>	 <p>1 pc</p>
 <p>1 pc</p>	 <p>1 pc</p>	 <p>1 pc</p>	 <p>2 pcs</p>
 <p>2 pcs</p>			

Hardware List

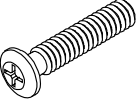
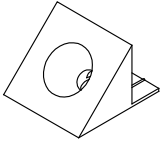
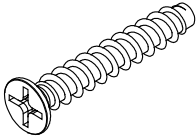
A	O	B	C	D	E
					
M6x35mm	Ø15x12mm	Ø8x30mm	Ø3.5x35mm	Ø3.5x14mm	96mm
36 pcs	40 pcs	20 pcs	4 pcs	82 pcs	5 pcs

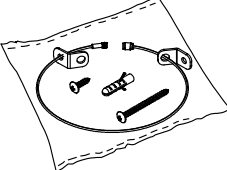
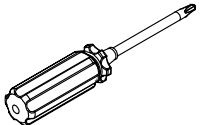
F	G	H	J	K	L
					
M4x18mm		M4x18mm			
10 pcs	24 pcs	7 pcs	8 pcs	2 pcs	1 pc

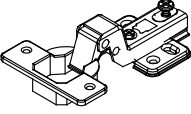
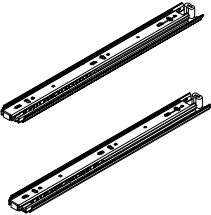
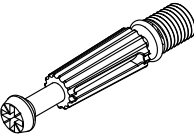
M	N	P			
					
	300mm	M6x35mm			
8 pcs	1 set	4 pcs			

Installation of Cams and Pins

Read each step carefully before starting. Each step of instruction should be performed in the correct order. If these steps are not followed in sequence, assembly difficulties may occur.

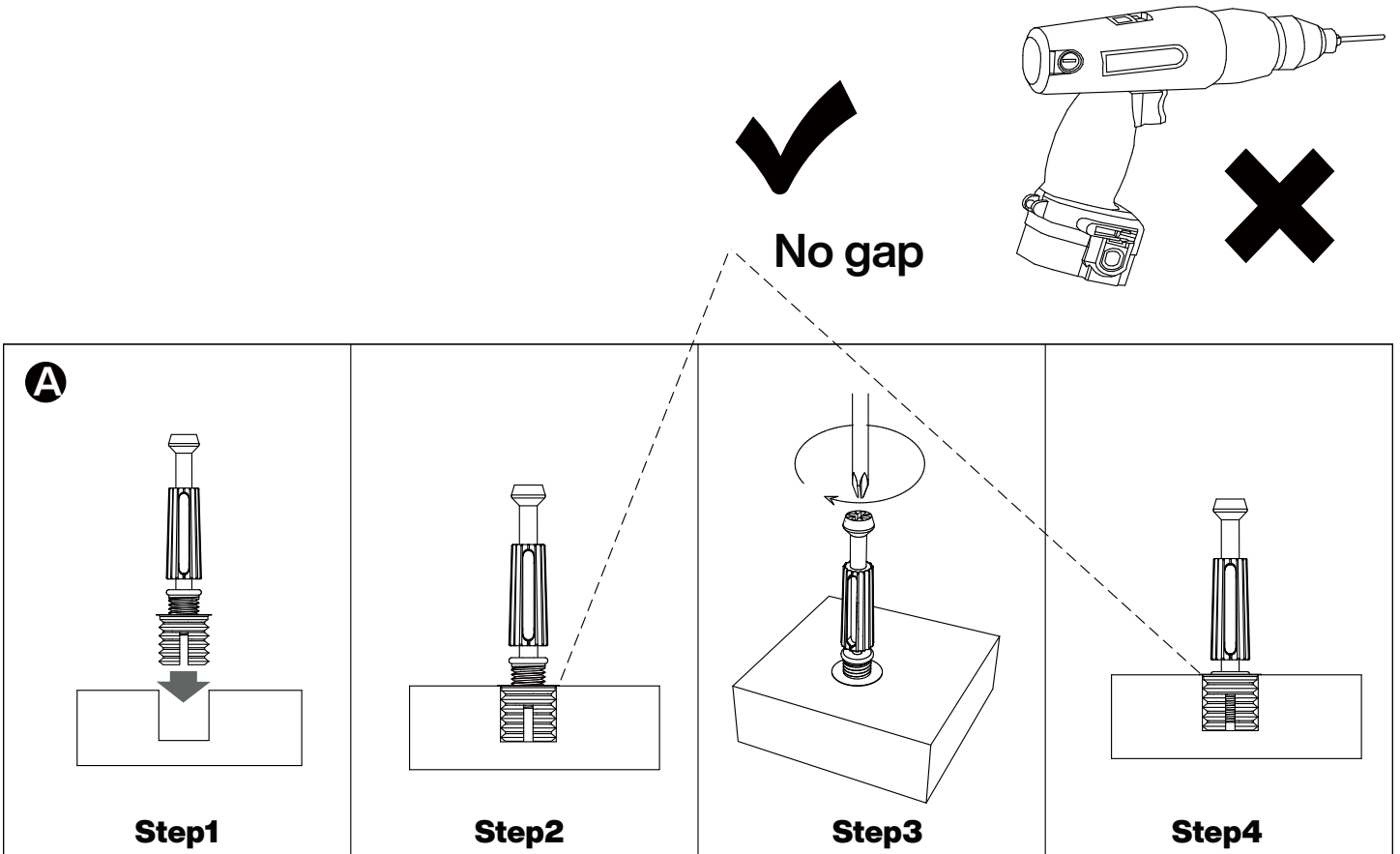

Screw the pin into the hole. Set the cams correctly by aligning the head of the cams with the lock pins. Lock the cam by turning the cam head with a screwdriver until it is tightened. Please do not use an electric screwdriver to assemble the unit.

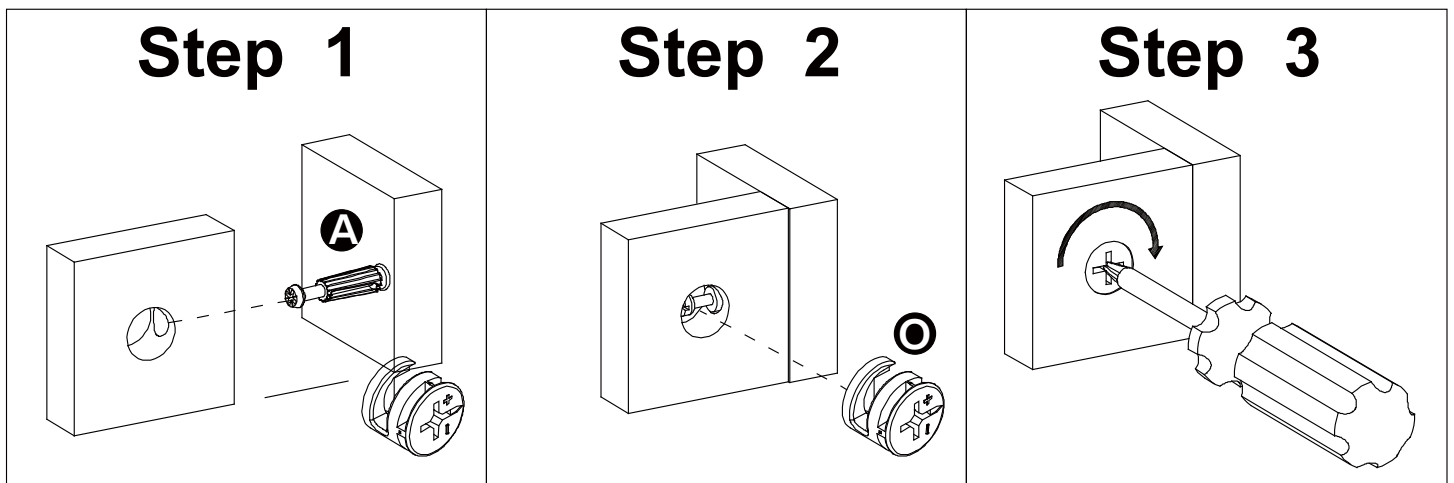

Please split component "N" into "N-1" and "N-2" before assembling the slide and then proceed to the next step of assembly

Step 1

Pull apart component "N" to each side, and then gently push up the lever of component "N-1"

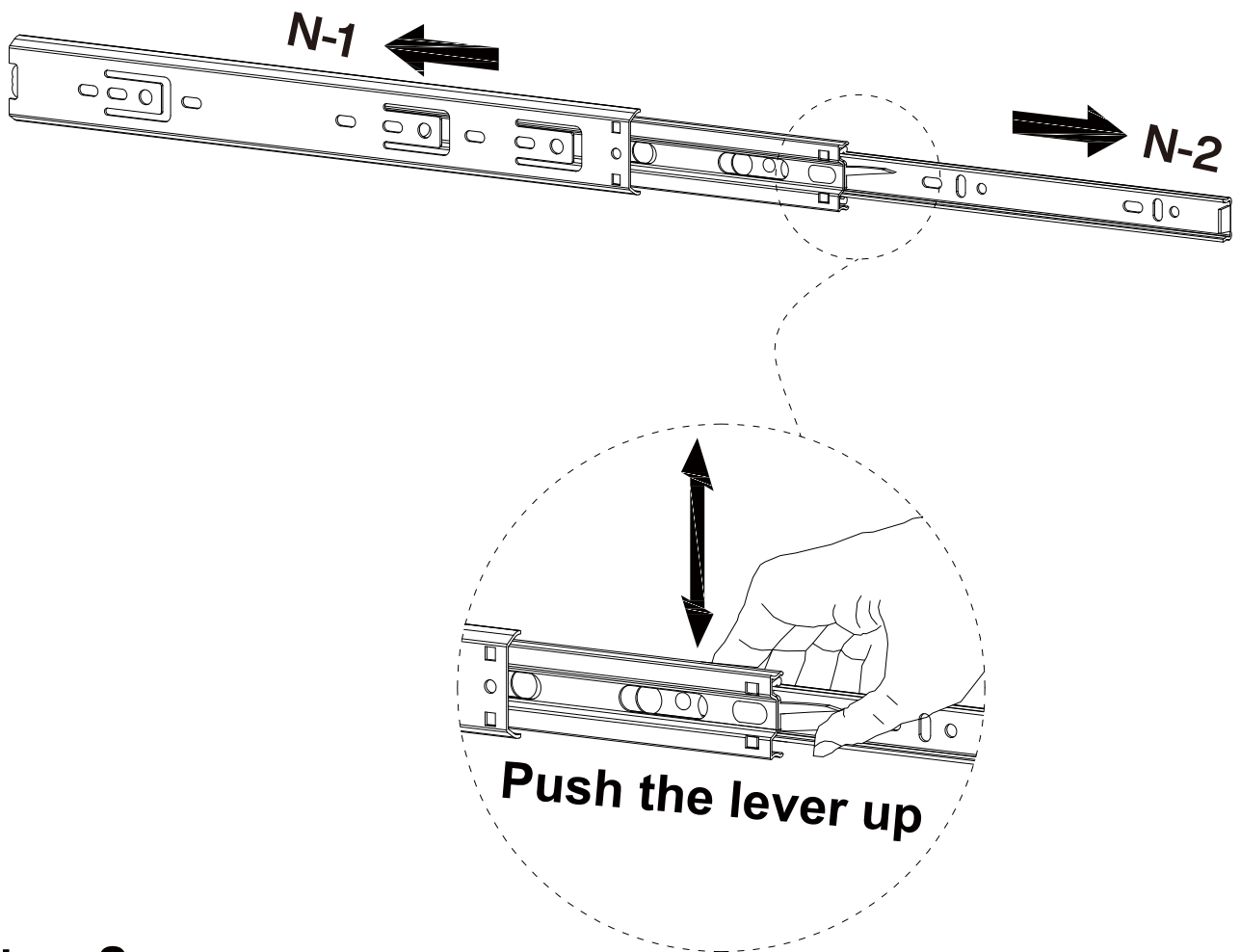

Step 2 Split component "N-1" and "N-2"

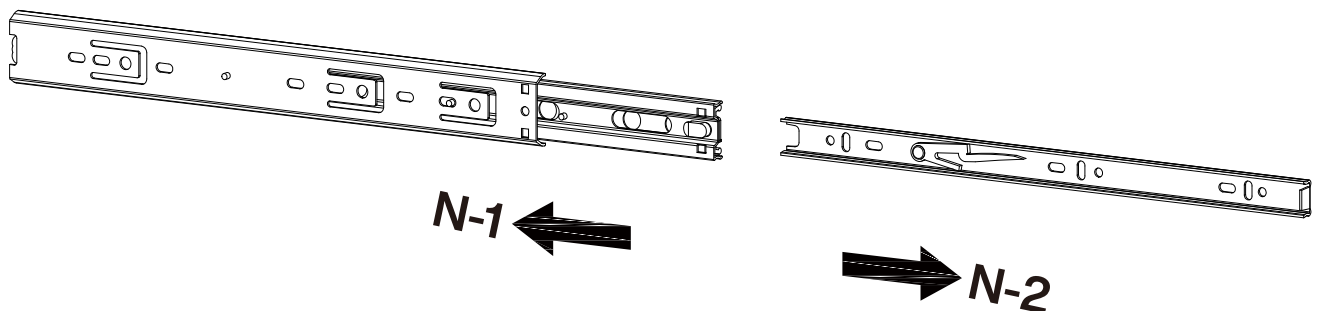

1

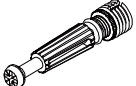
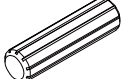
A	B
	
M6x35mm	Ø8x30mm
4 pcs	4 pcs

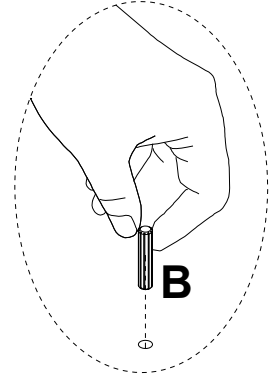
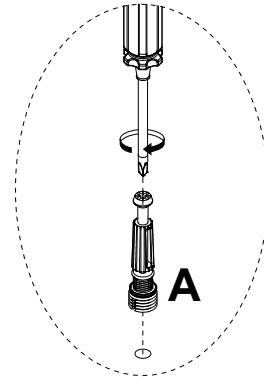
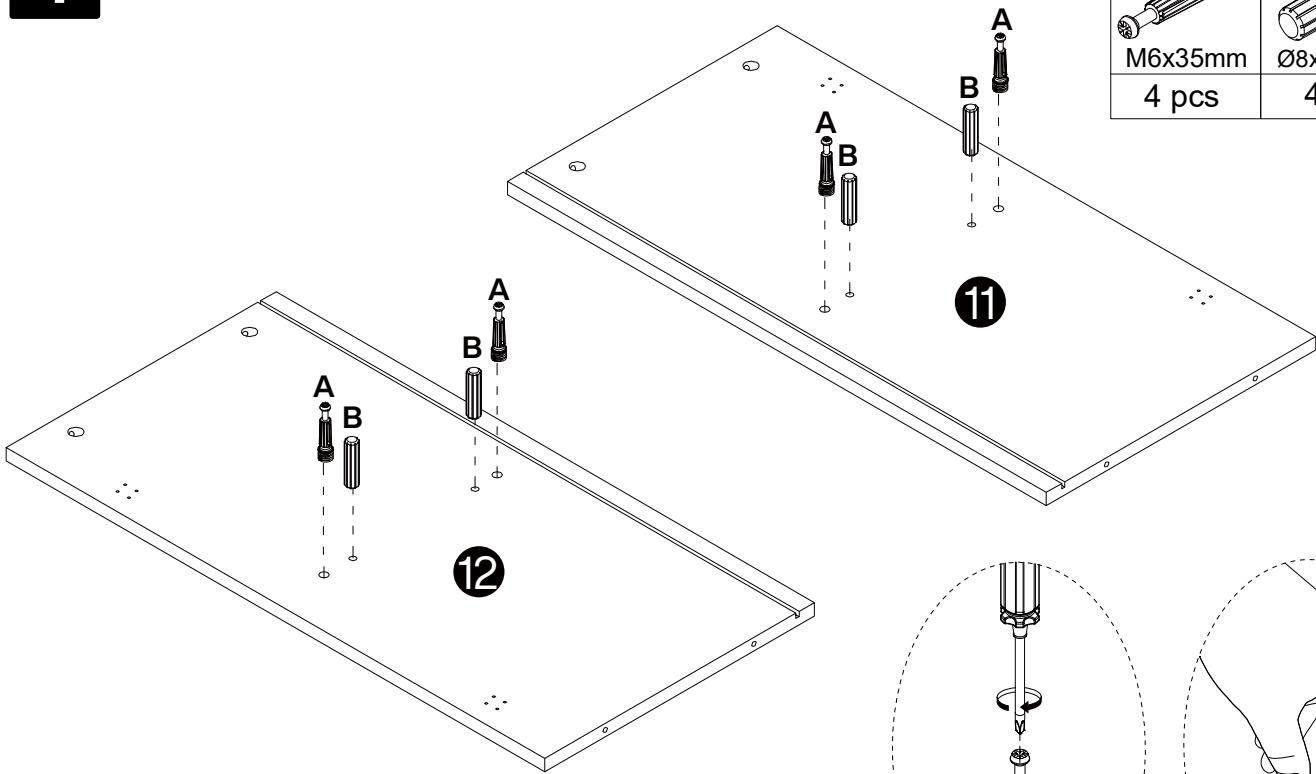

2

O

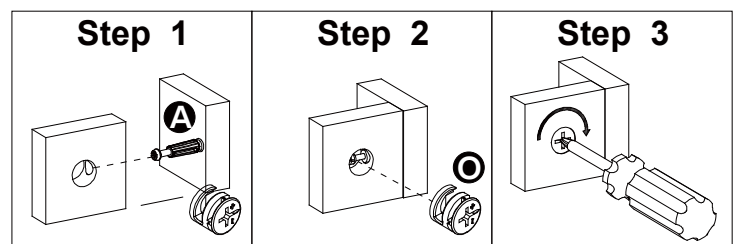
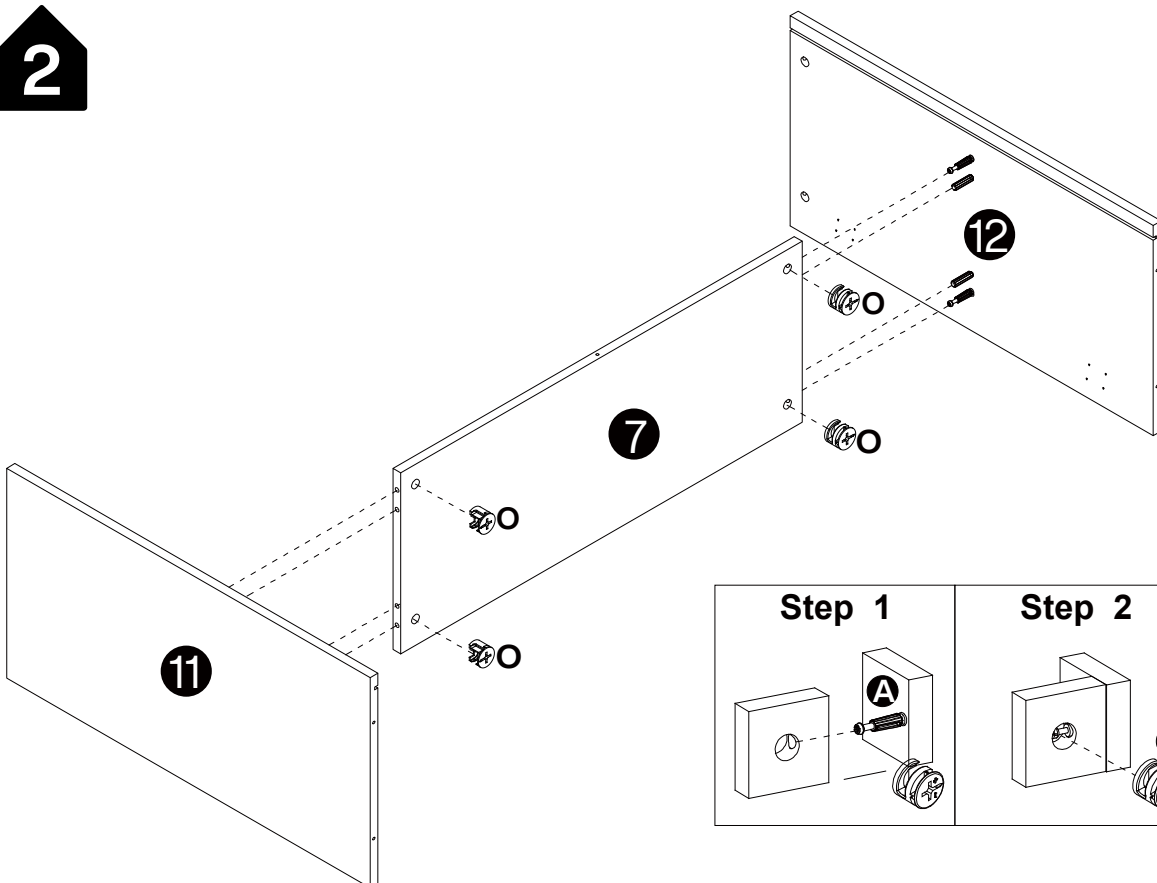
Ø15x12mm
4 pcs

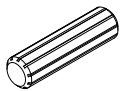

3

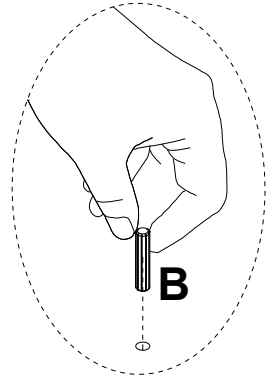
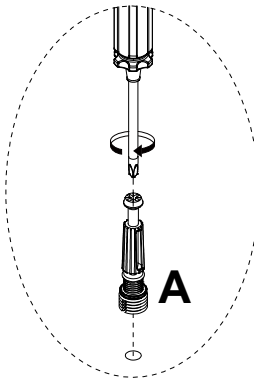
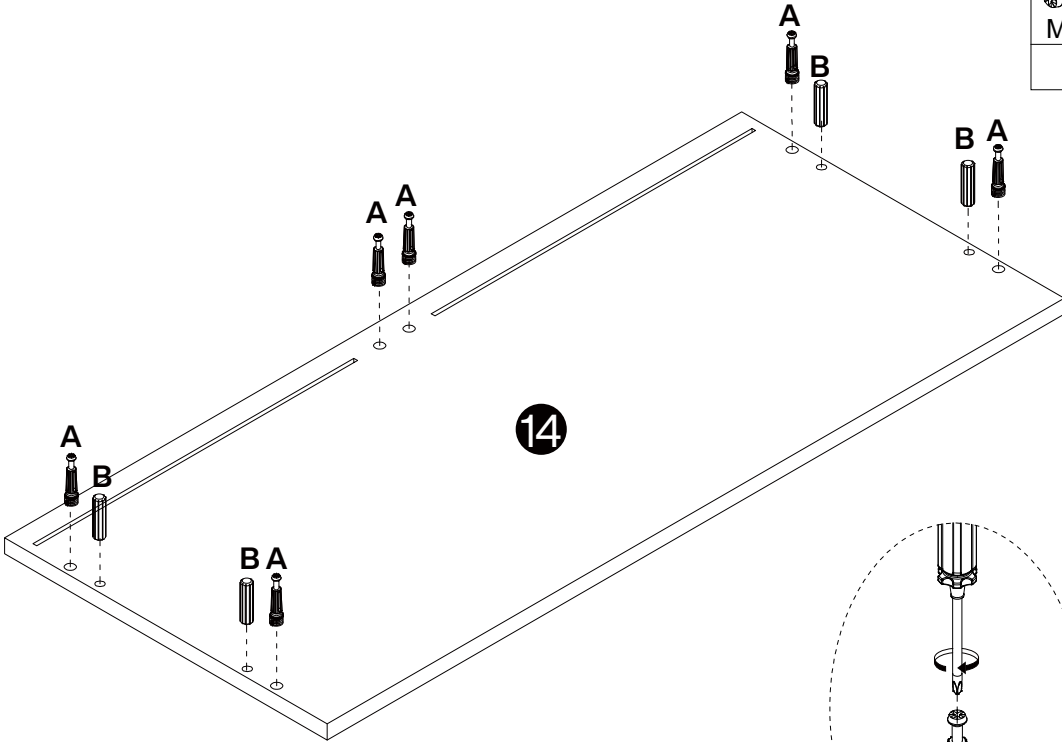
A	B
	
M6x35mm	Ø8x30mm
6 pcs	4 pcs



4

O

Ø15x12mm
4 pcs

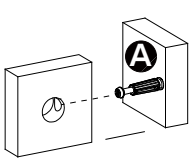
Step 1

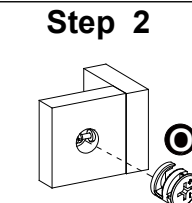

Step 2



Step 3

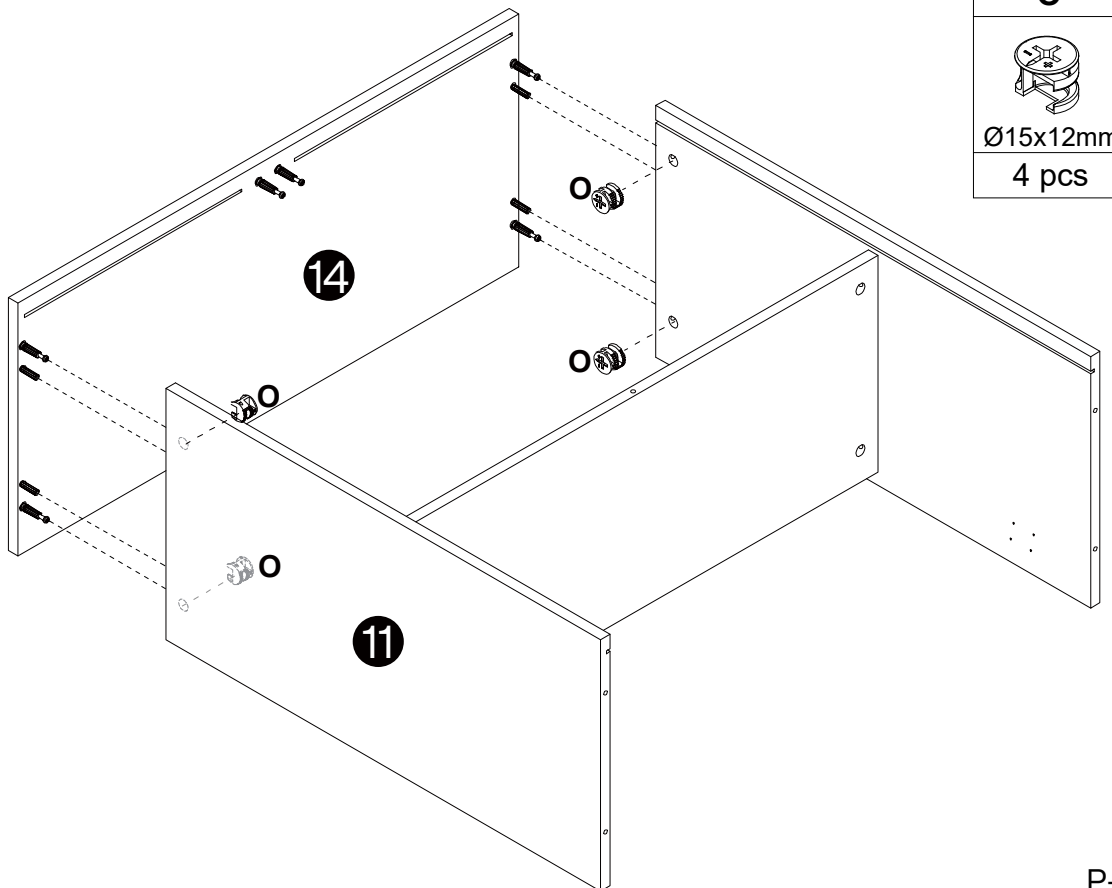
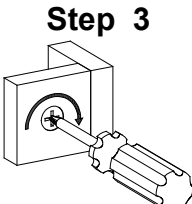

5

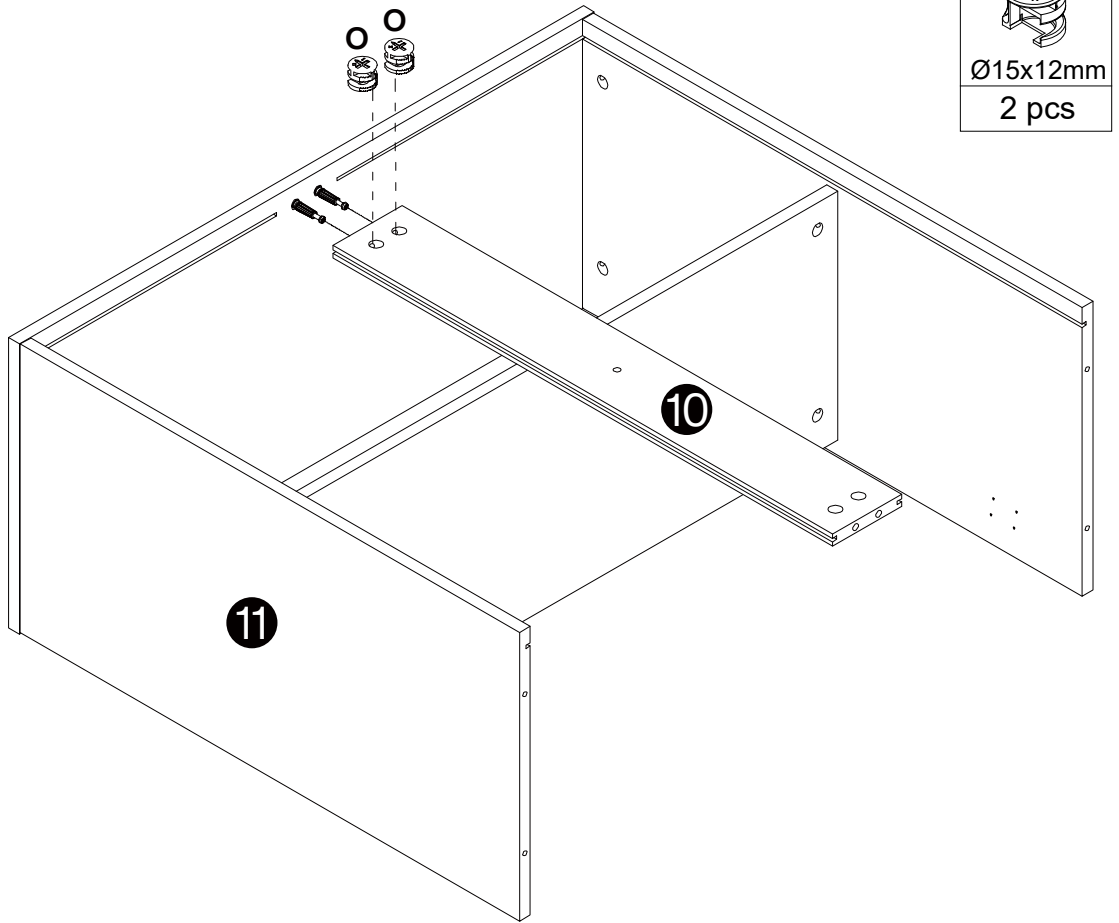
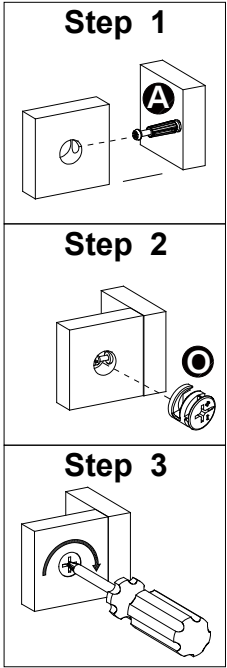

6

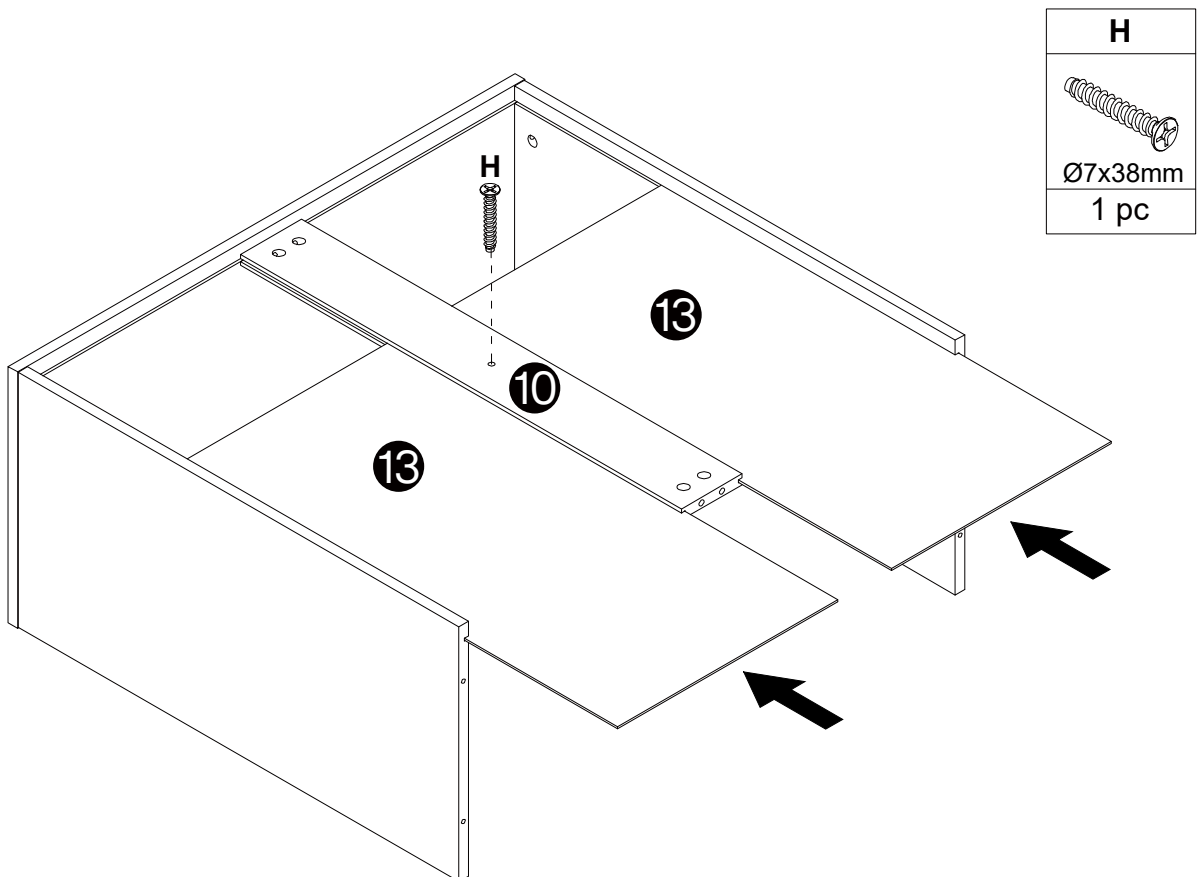

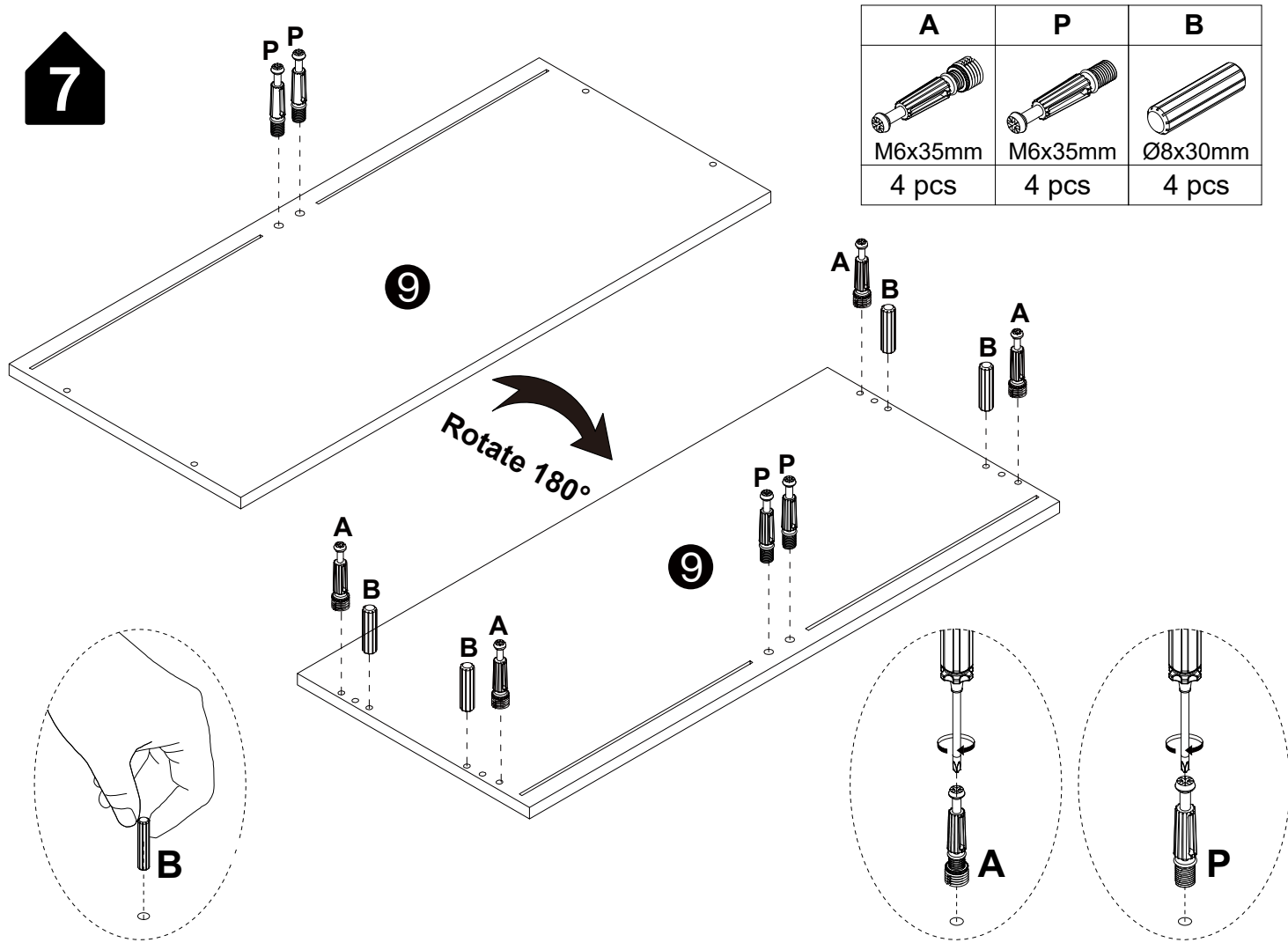

7

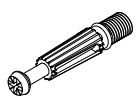
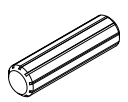

A	P	B
		
M6x35mm	M6x35mm	Ø8x30mm
4 pcs	4 pcs	4 pcs

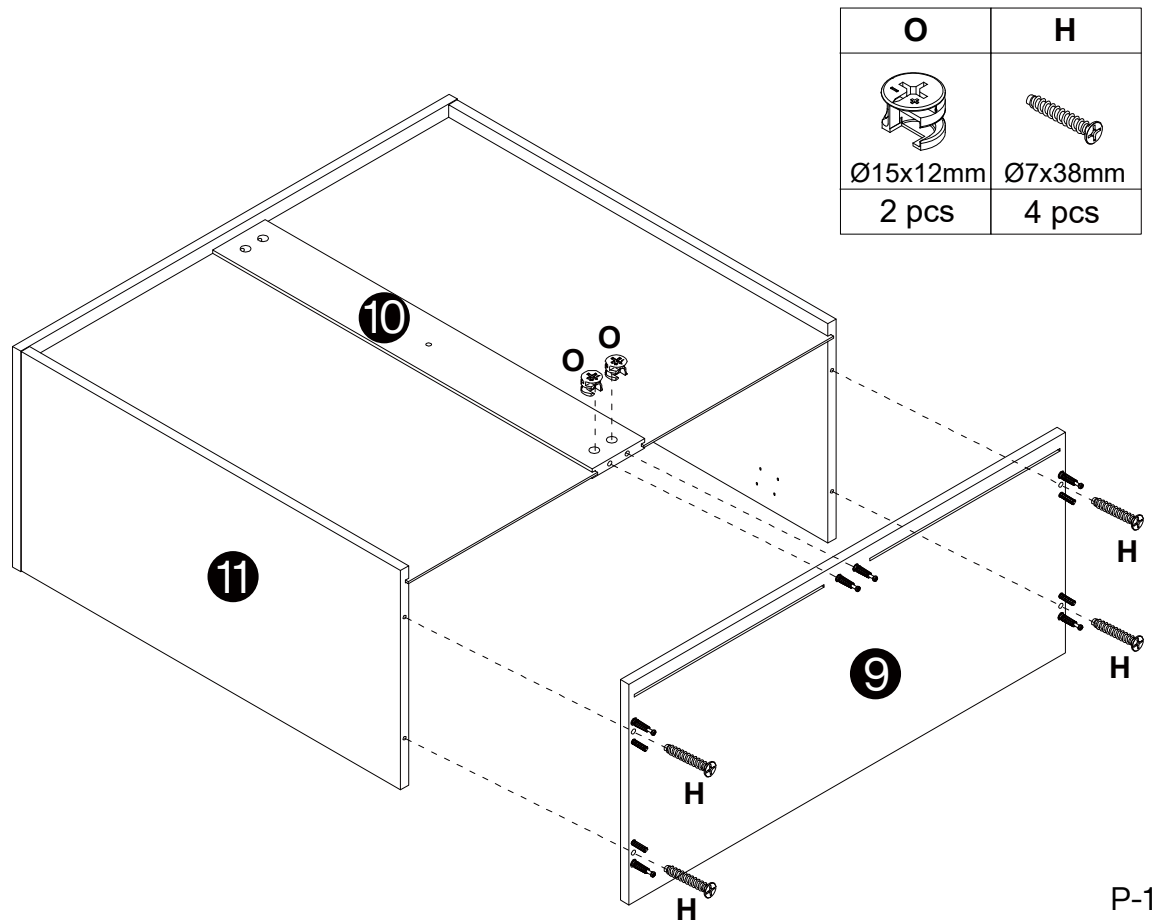
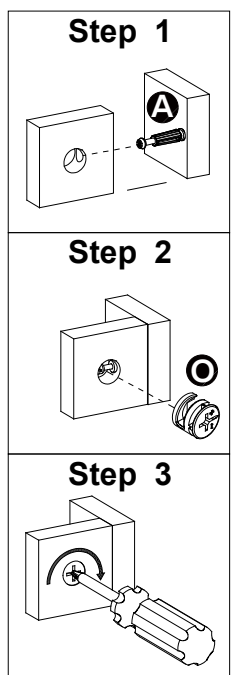

8



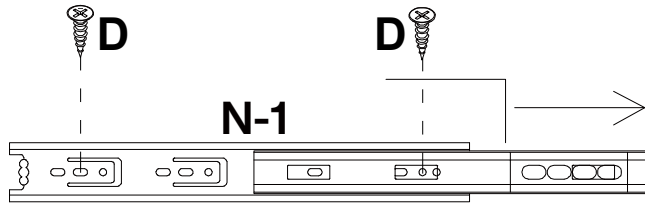

O	H
	
Ø15x12mm	Ø7x38mm
2 pcs	4 pcs

9





A	B
	
M6x35mm	Ø8x30mm
8 pcs	4 pcs

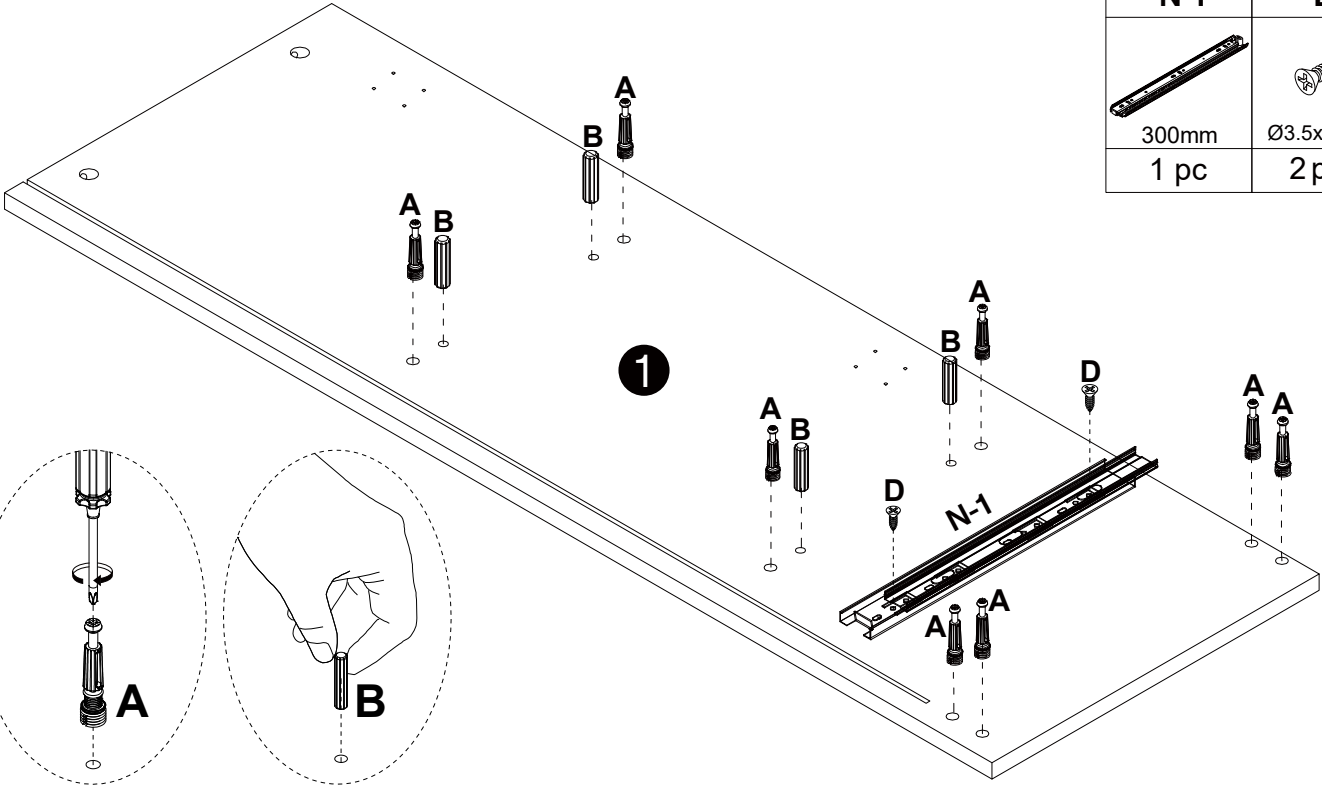

N-1	D
	
300mm	Ø3.5x14mm
1 pc	2 pcs

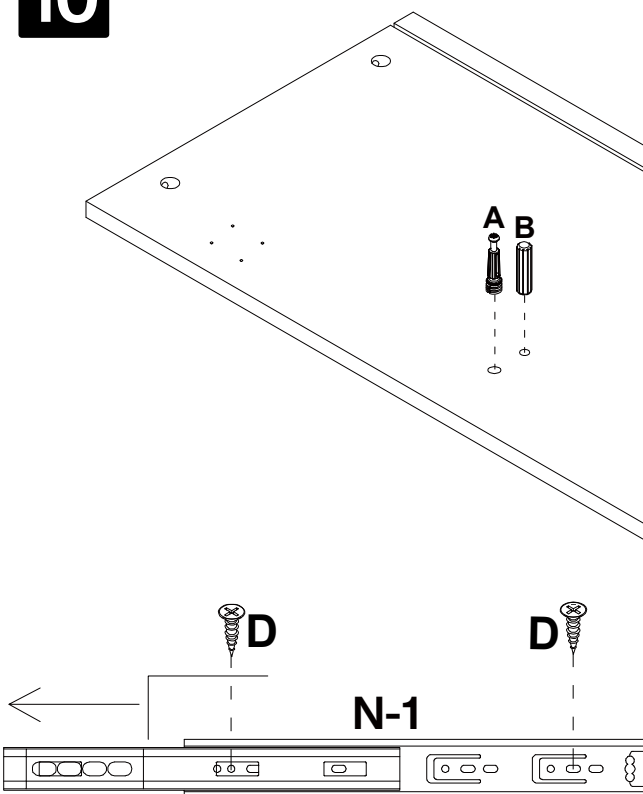

10



A	B
	
M6x35mm	Ø8x30mm
8 pcs	4 pcs

N-1	D
	
300mm	Ø3.5x14mm
1 pc	2 pcs

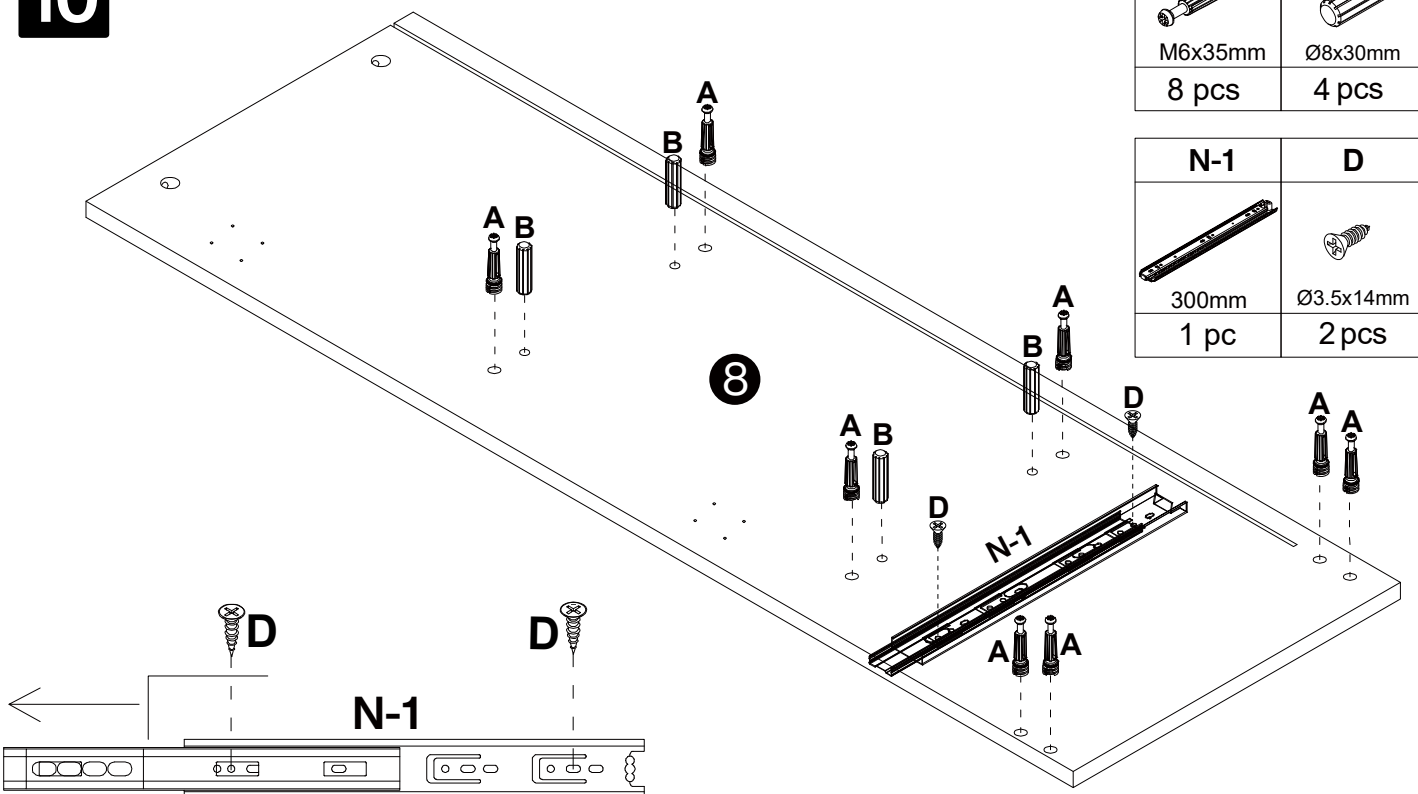

11

A

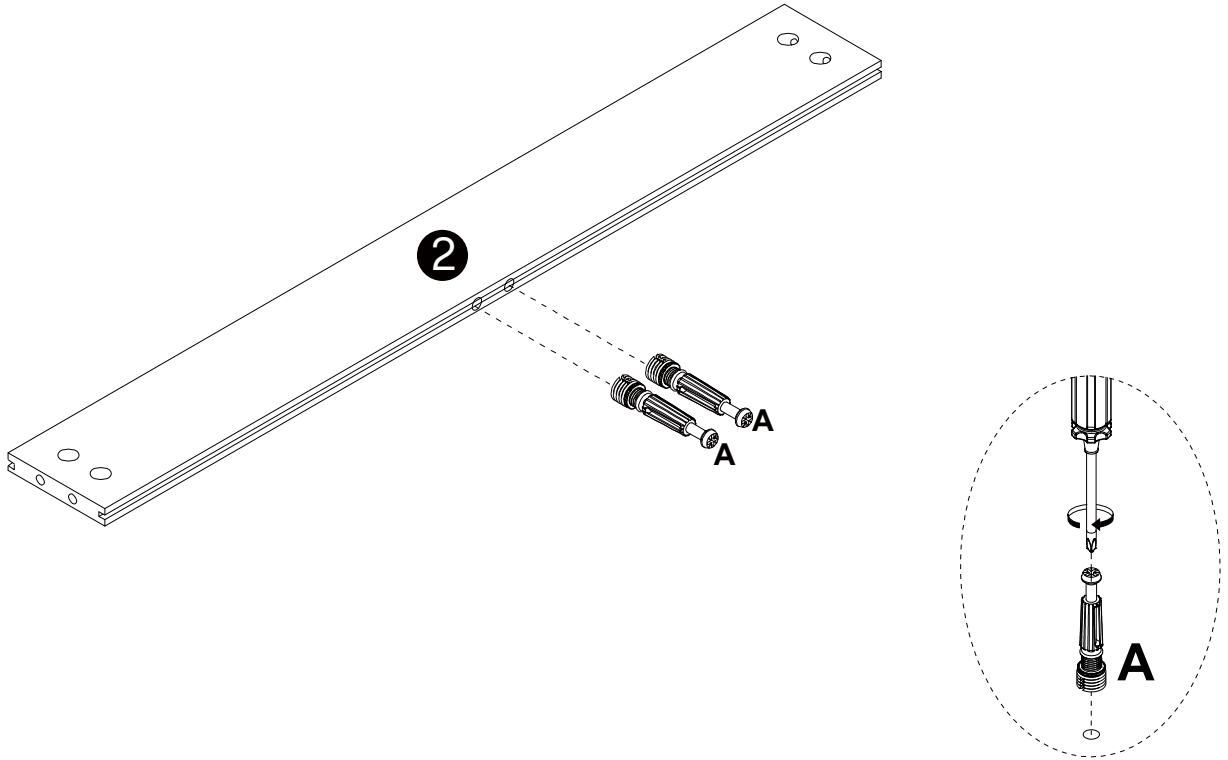
M6x35mm
2 pcs

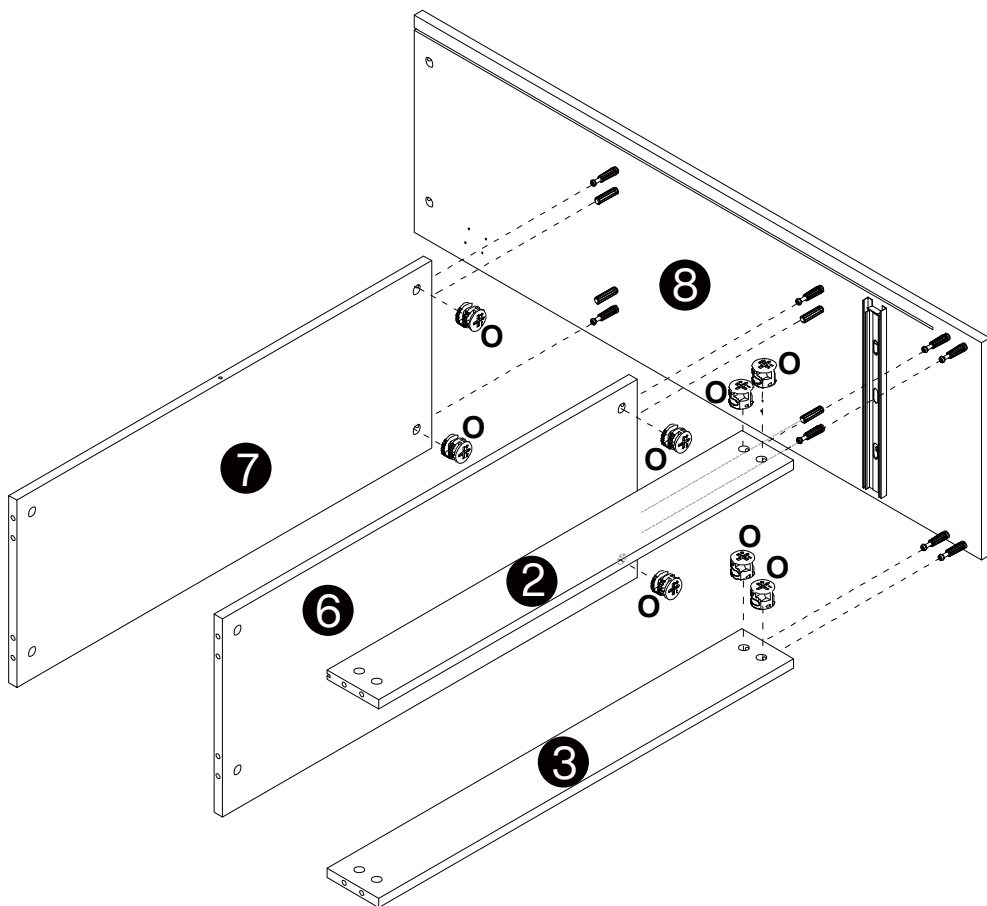
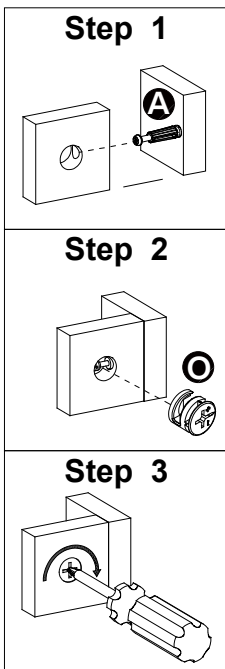

12

O

Ø15x12mm
8 pcs



13

0

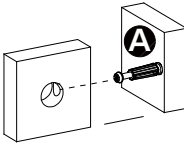
Ø15x12mm
8 pcs

Step 1

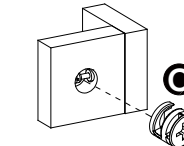

Step 2



Step 3

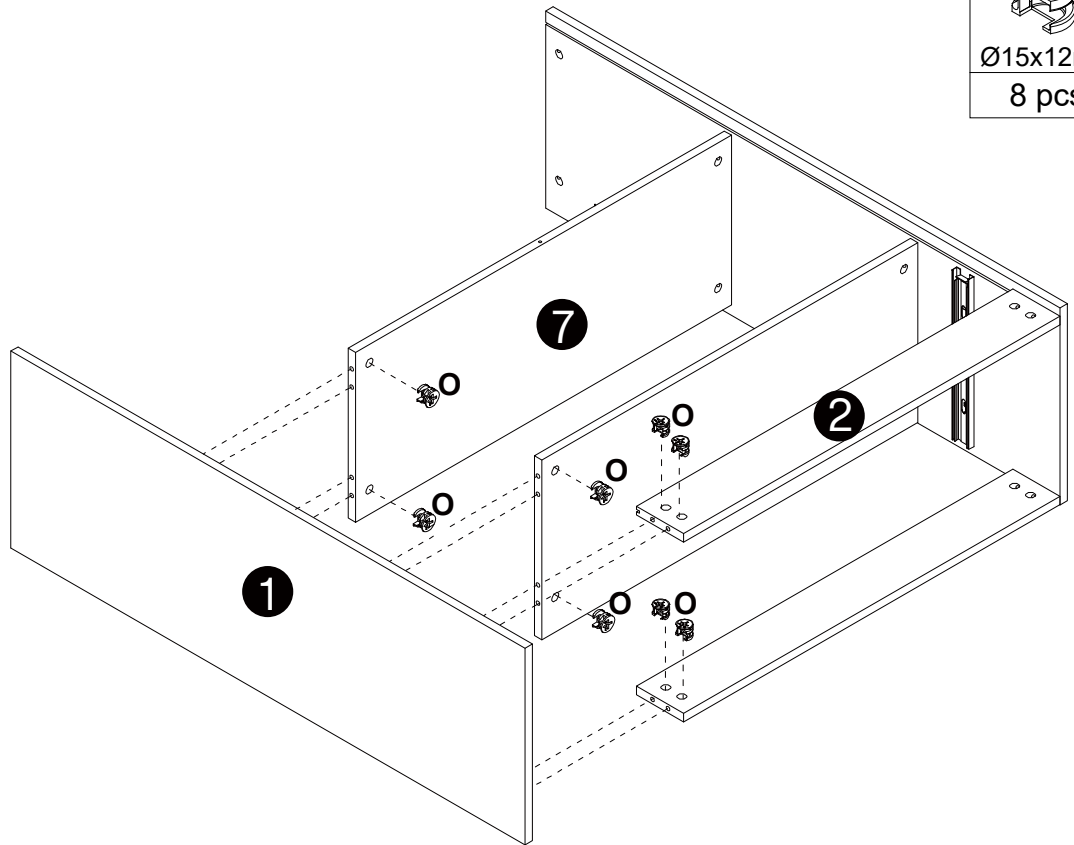
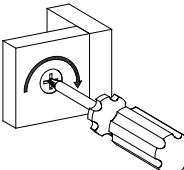

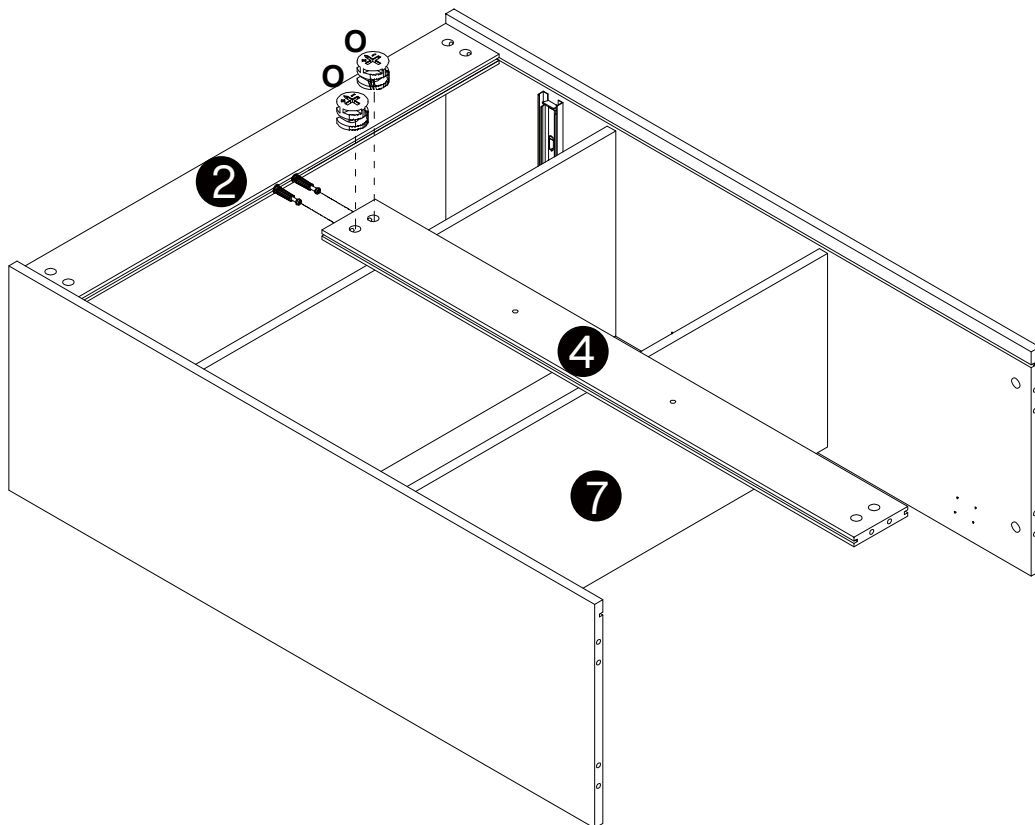

14

0

Ø15x12mm
2 pcs

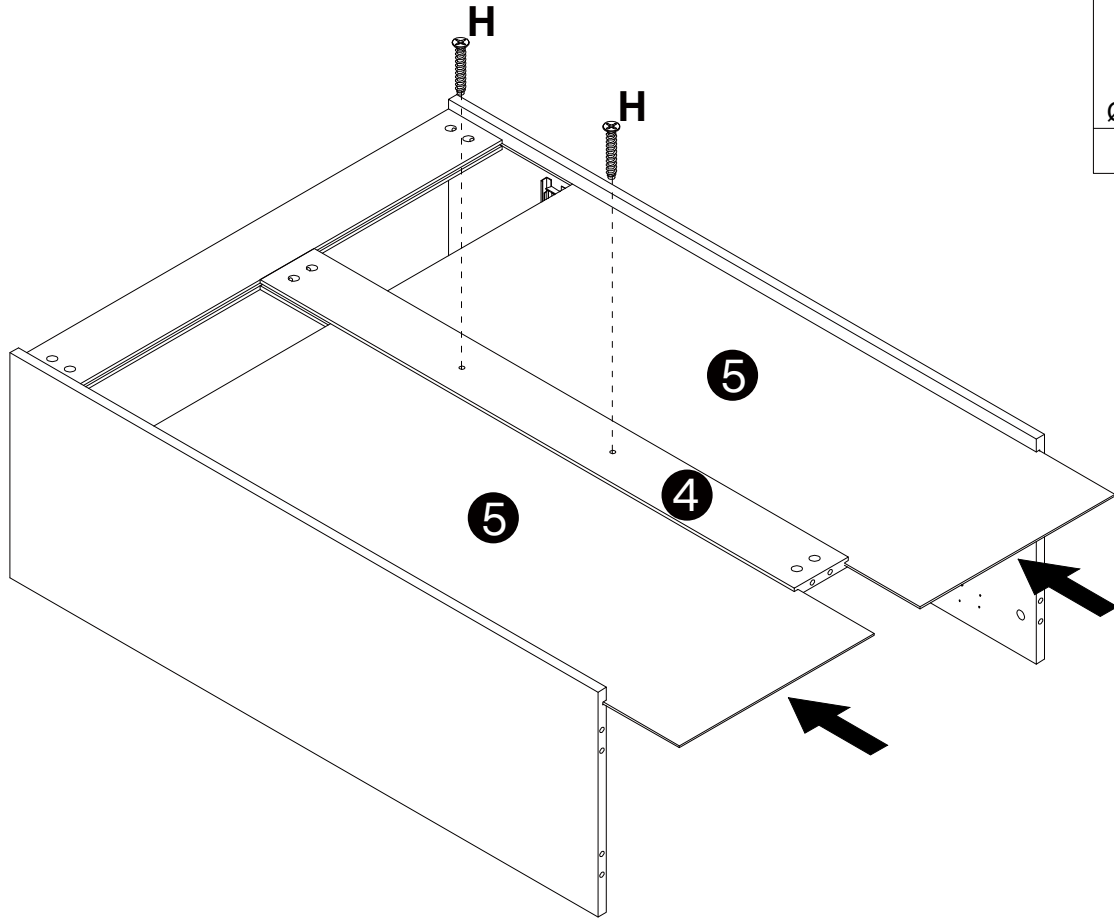



15

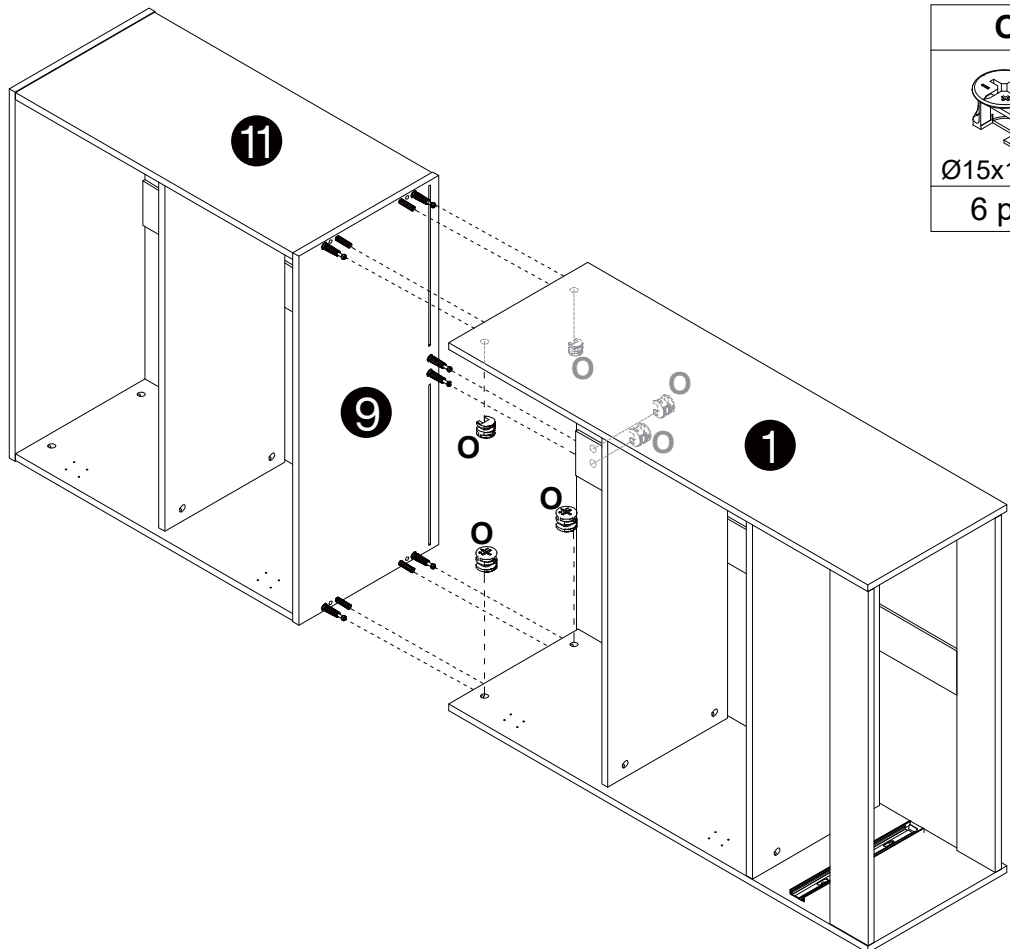

H

Ø7x38mm
2 pcs

16

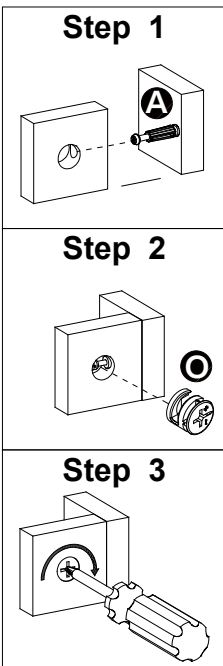

O

Ø15x12mm
6 pcs



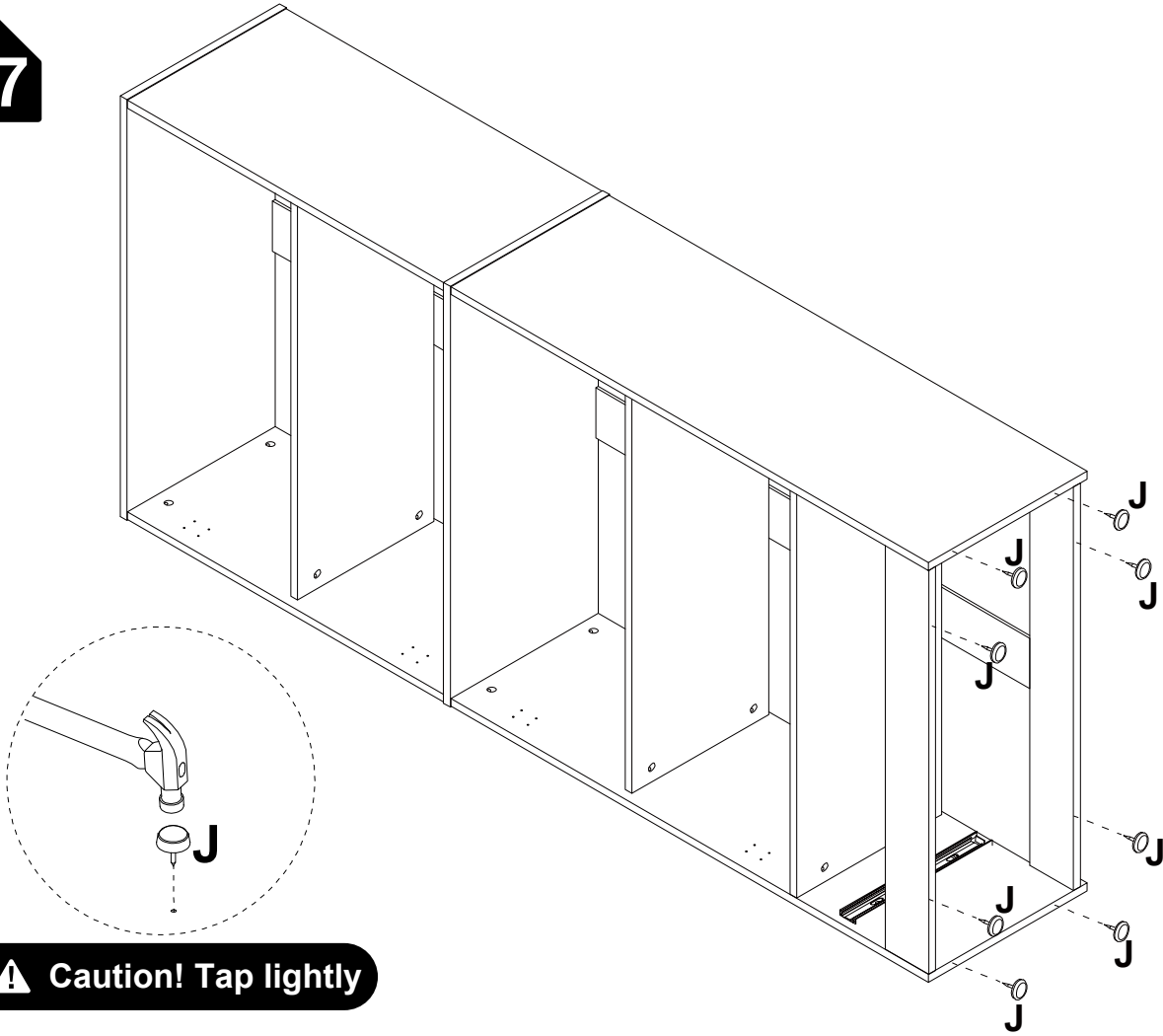

17

J

8 pcs

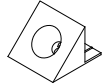

⚠ Caution! Tap lightly

18

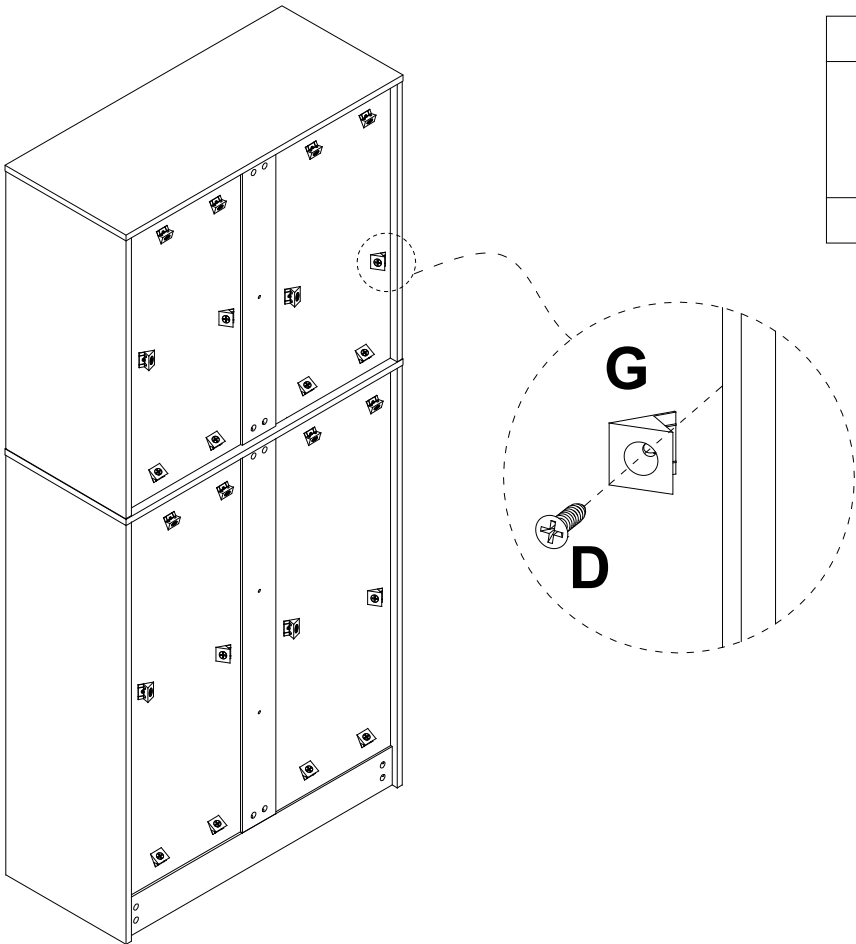
G	D
	
24 pcs	Ø3.5x14mm 24 pcs



19

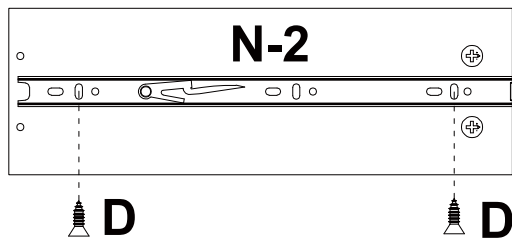

N-2	D
	 Ø3.5x14mm
1 set	4 pcs

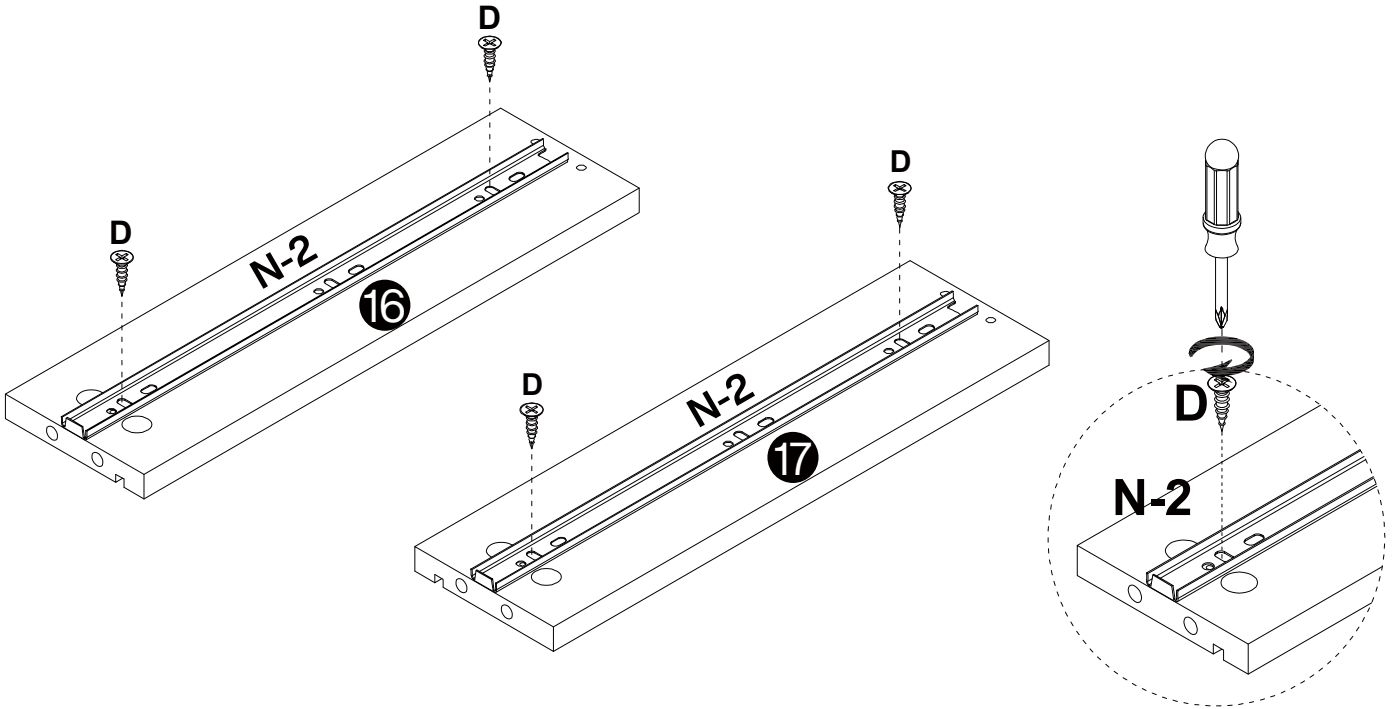

20

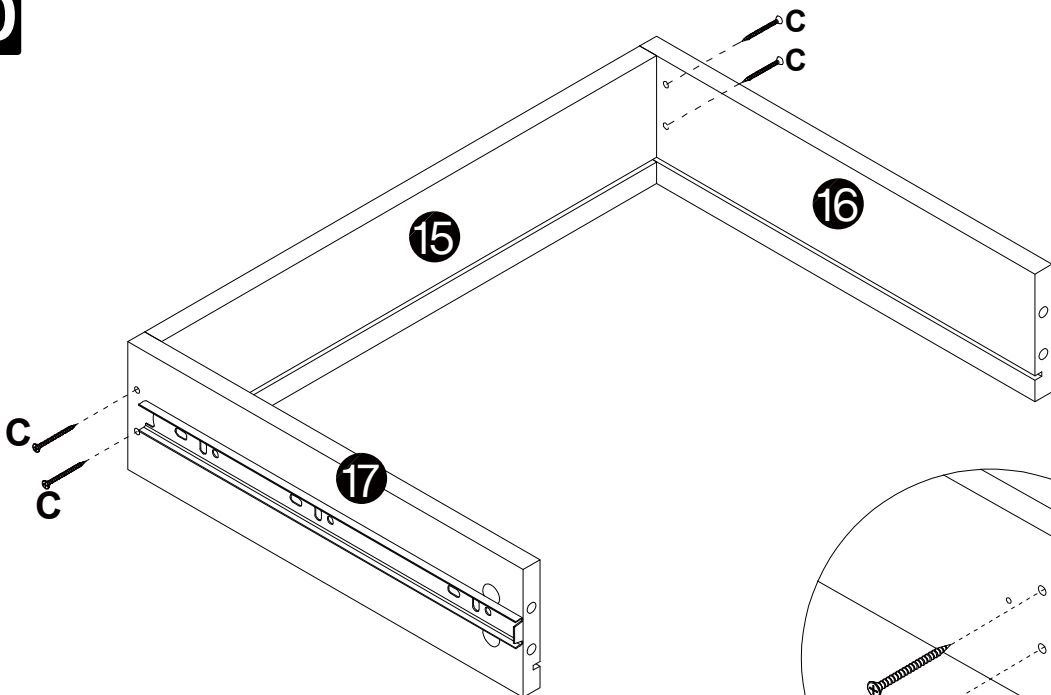

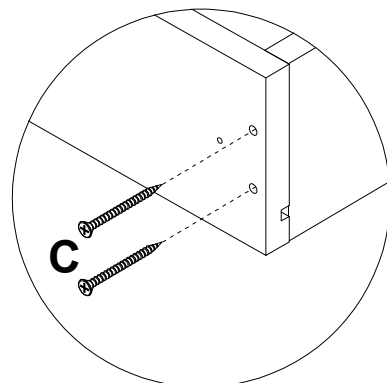

C
Ø3.5x35mm
4 pcs

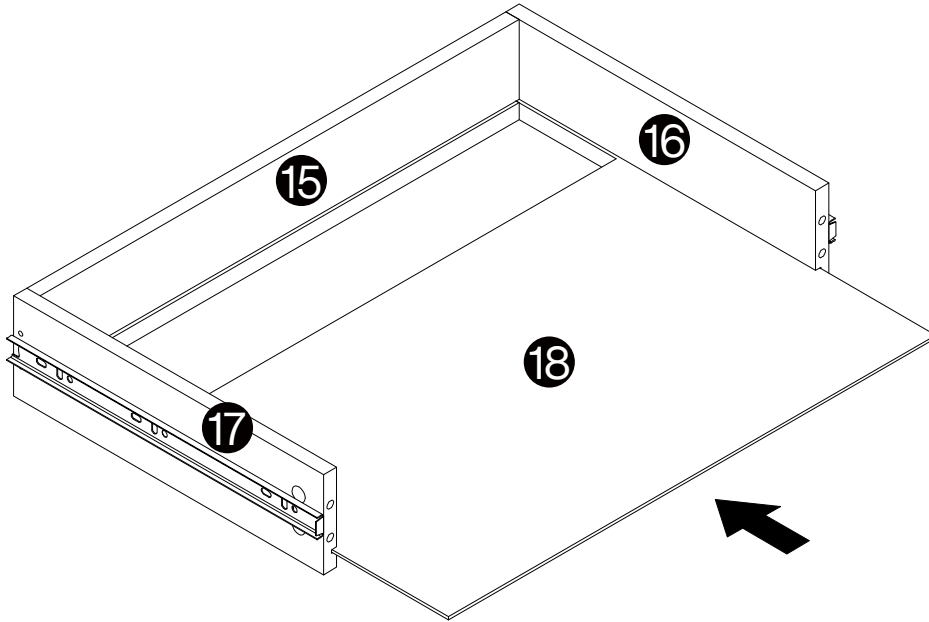

21



22

A	E	F
		
M6x35mm	96mm	M4x18mm
4 pcs	1 pcs	2 pcs

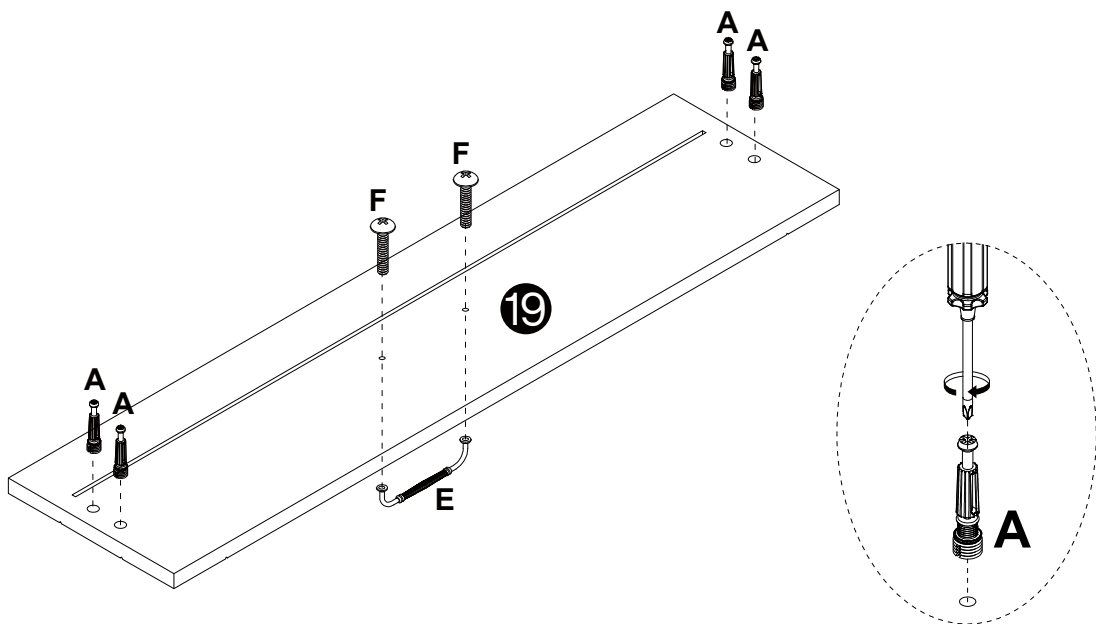

23

O

Ø15x12mm
4 pcs

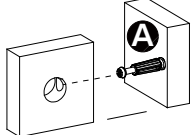
Step 1



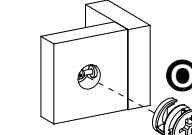

Step 2

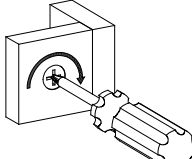
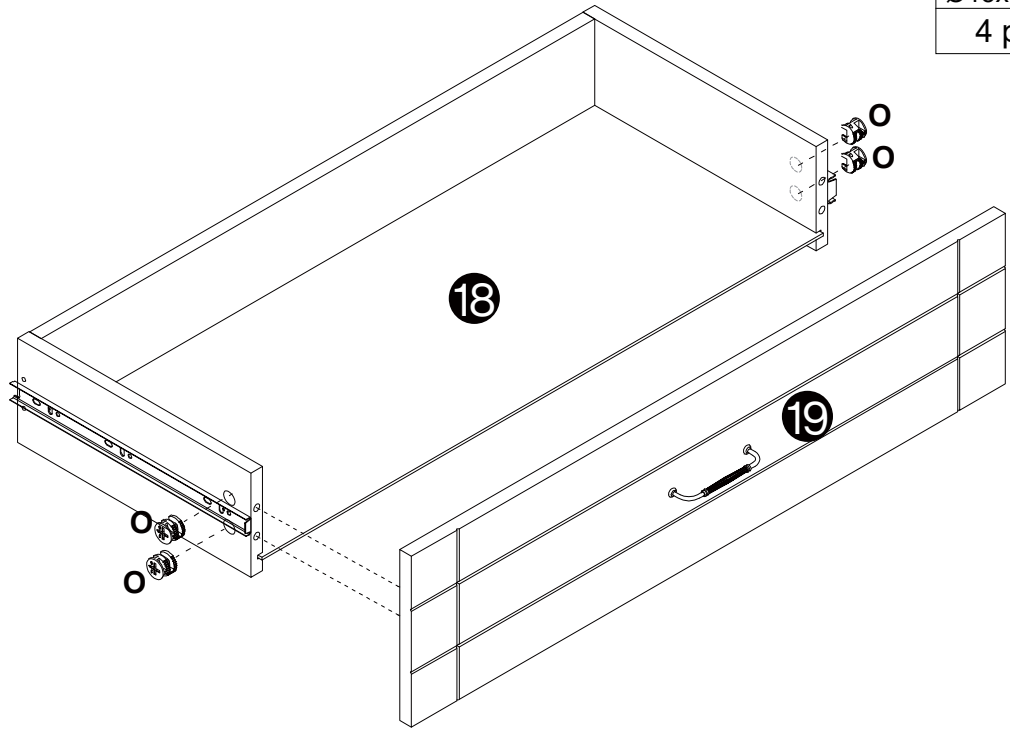

Step 3

24

D	E
	
Ø3.5x14mm	96mm
8 pcs	2 pcs

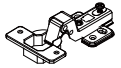

F	M
	
4 pcs	4 pcs

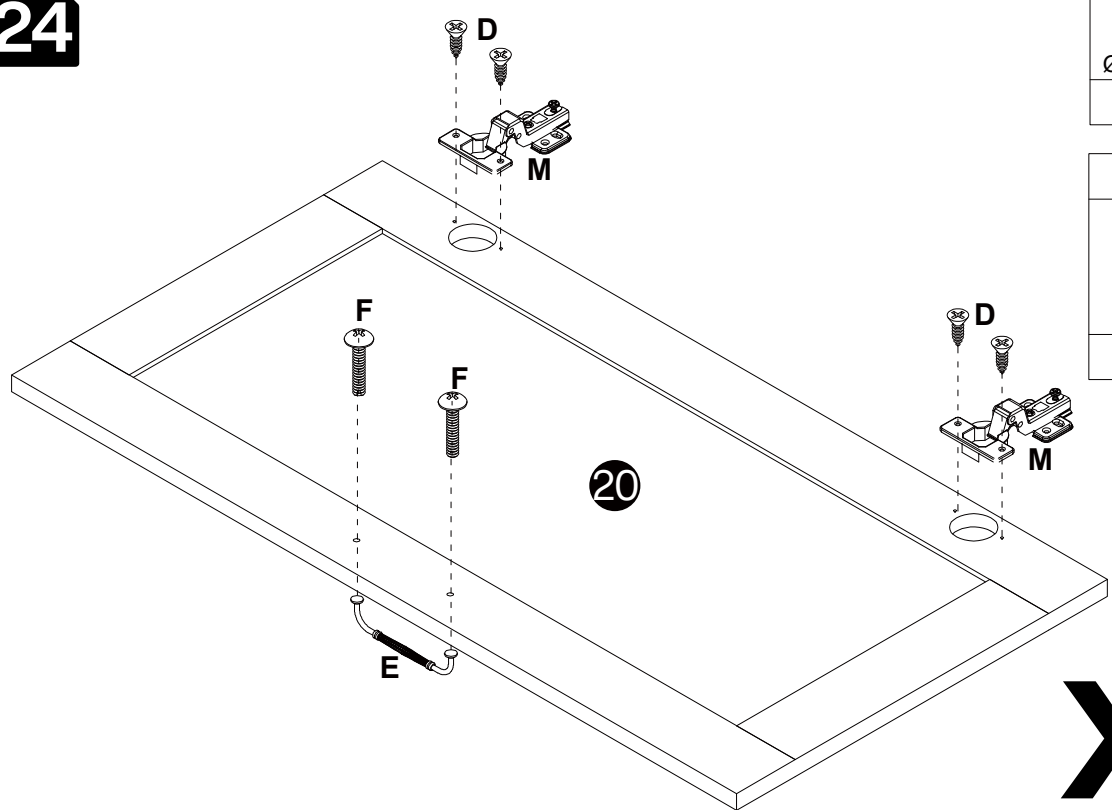

x2

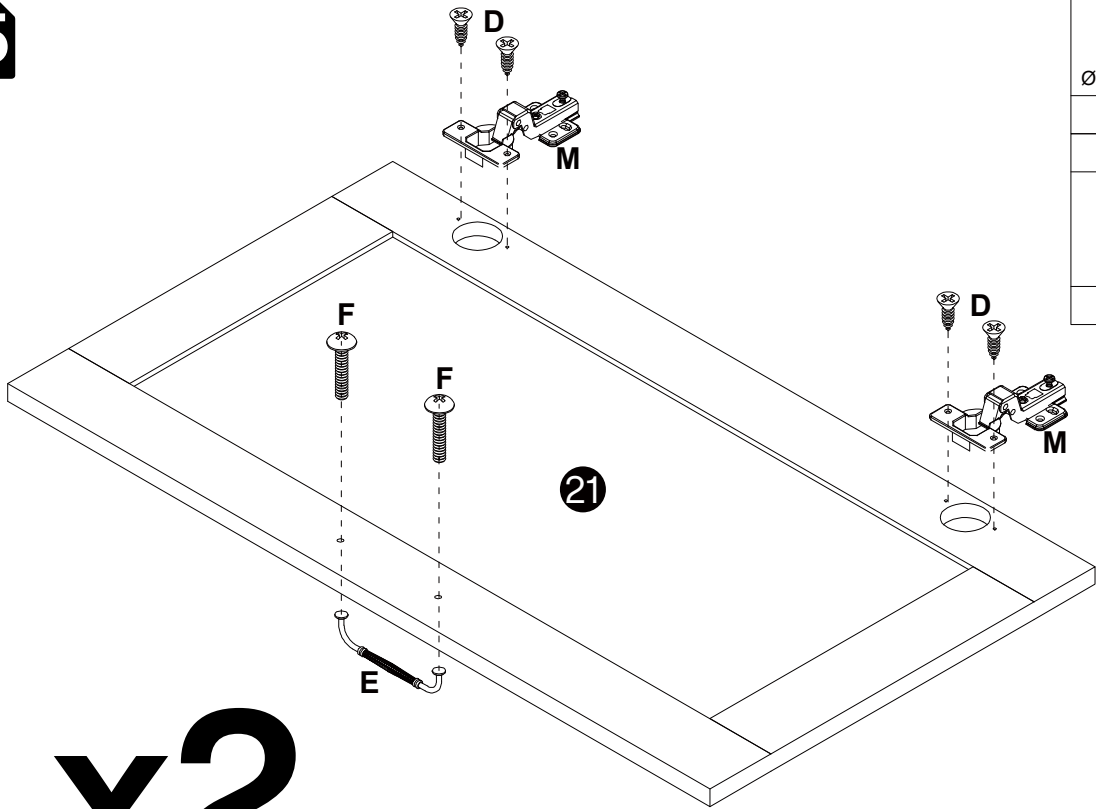
25

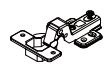

D	E
 Ø3.5x14mm	 96mm
8 pcs	2 pcs
F	M
	
4 pcs	4 pcs

x2

26

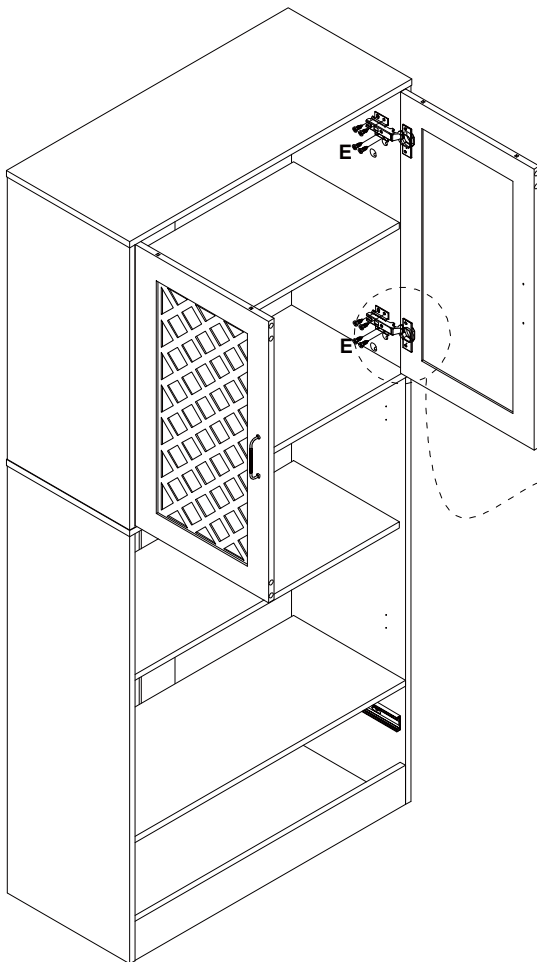

E
 Ø3.5x14mm
16 pcs

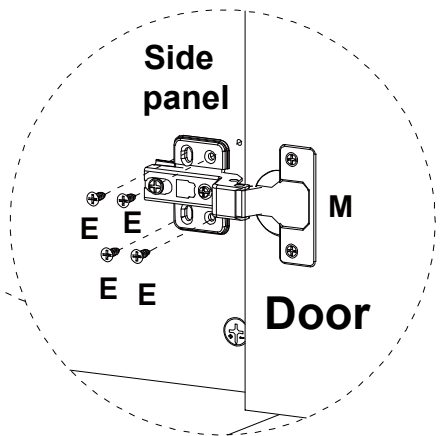

27

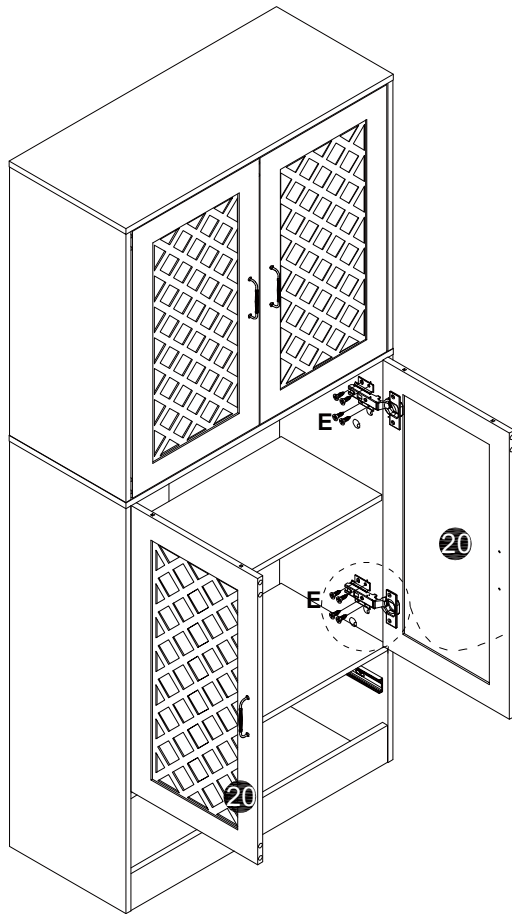

E

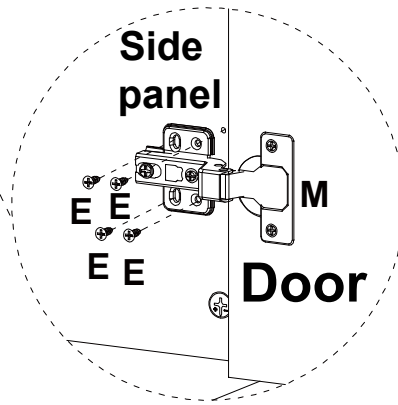
Ø3.5x14mm
16 pcs

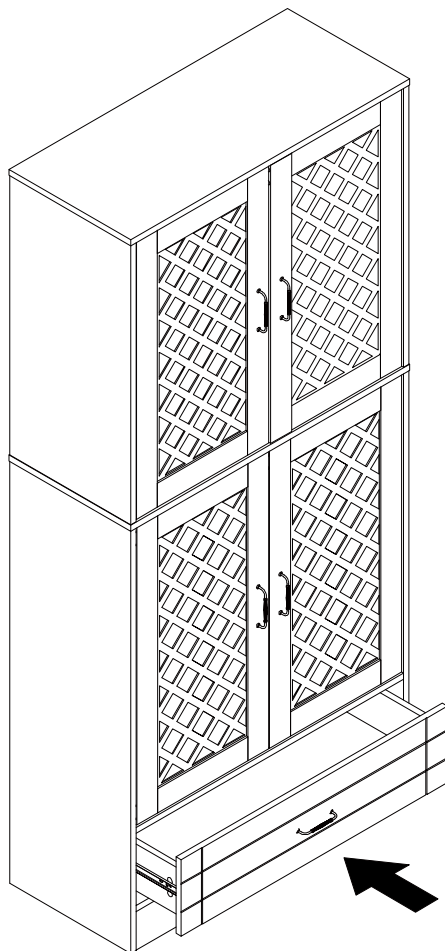

28



Step 1

Open the door.

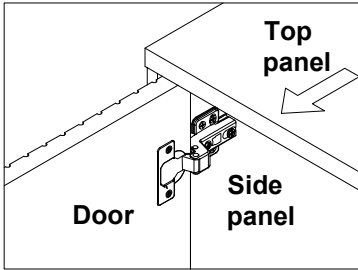

ADJUST YOUR DOORS TO MAKE THE GAPS MORE EVEN (OPTIONAL).

Step 2

Adjust the door panel to be flush with side panel and top panel edge.

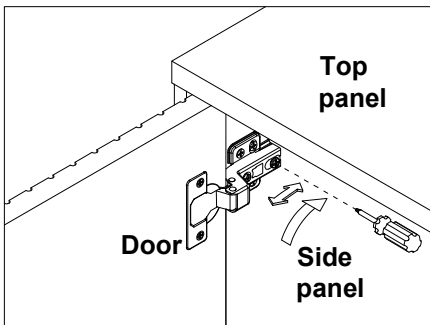

Loosen the screw indicated a little, adjust the hinge to the right position (see step 2a & 2b), then tighten the screw.

Step 2a MOVE DOOR OUT

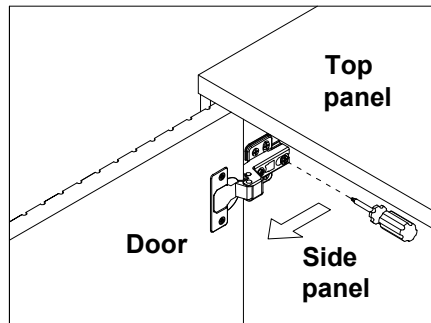
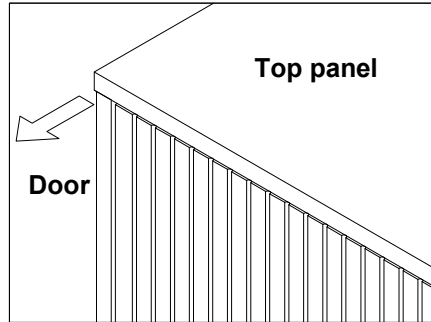

Pull the hinge forward a little.

Step 2b MOVE DOOR IN

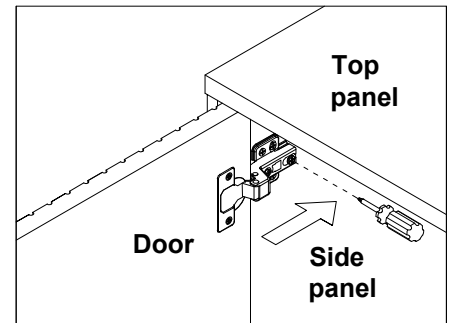
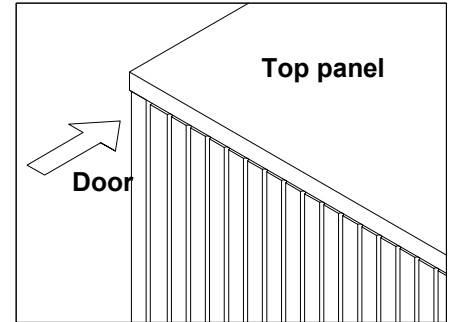

Push the hinge back a little.

Step 3

Adjust the gap between the door panel and the side panel.

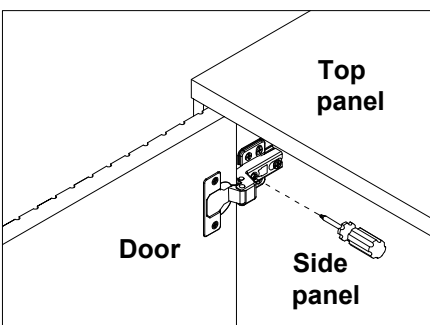

Loosen or tighten the screw indicated a little to adjust the gap between the door panels, adjust the hinge to the right position (see step 3a & 3b).

Step 3a MOVE DOOR LEFT

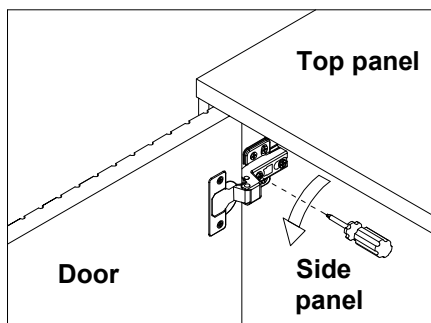
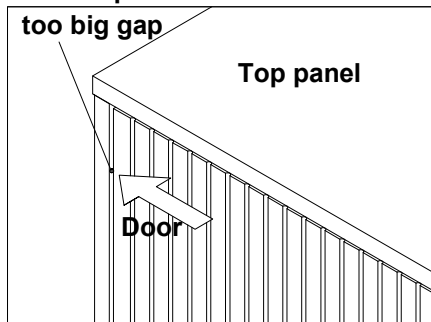

Turn the screw clockwise a little as shown to make the gap smaller

Step 3b MOVE DOOR RIGHT

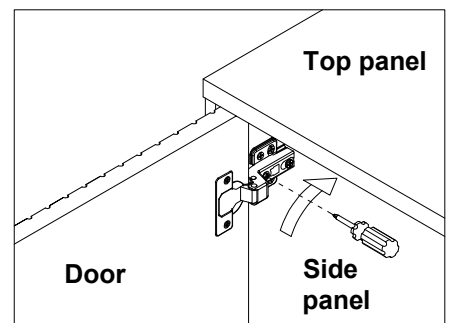
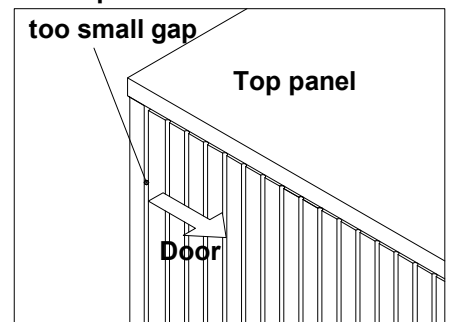

Turn the screw counterclockwise a little as shown to make the gap bigger

K

2 pcs

Wall

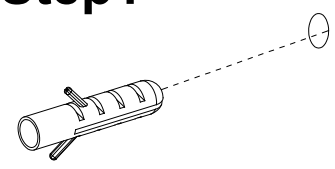
Step1

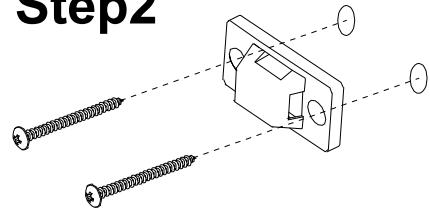

Step2



Step3

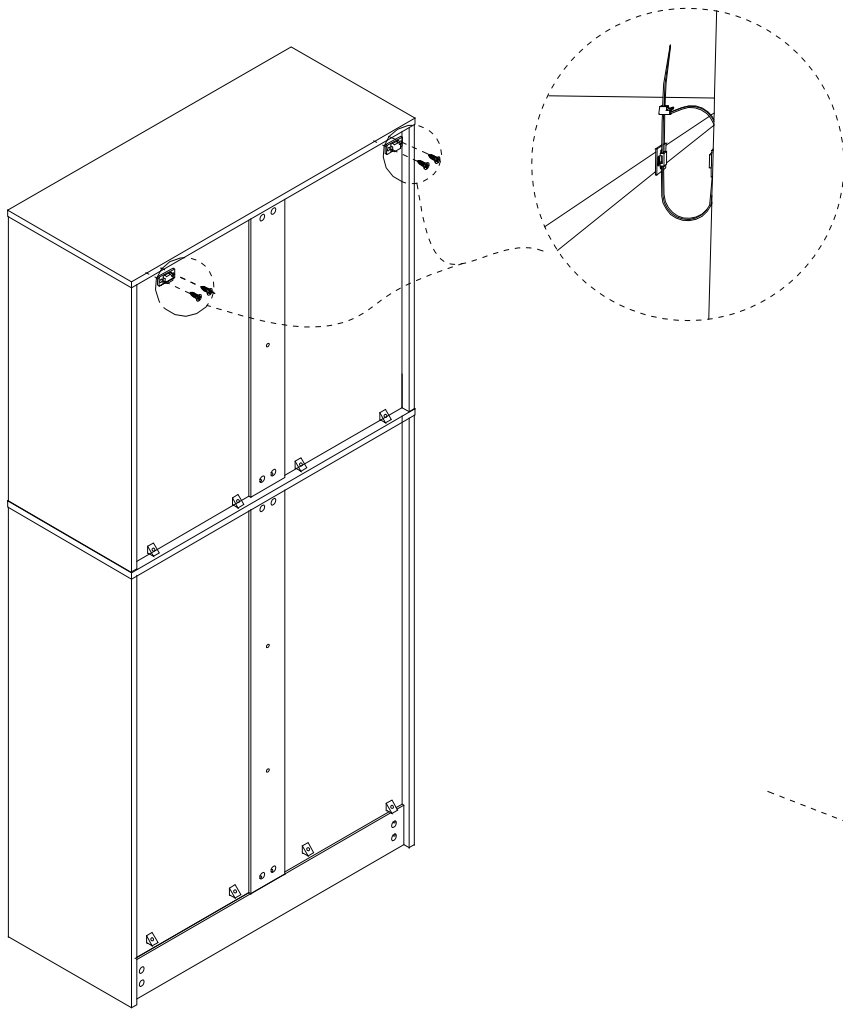

Thank you for your support!

