

Assembly Instructions

Shoe Cabinet

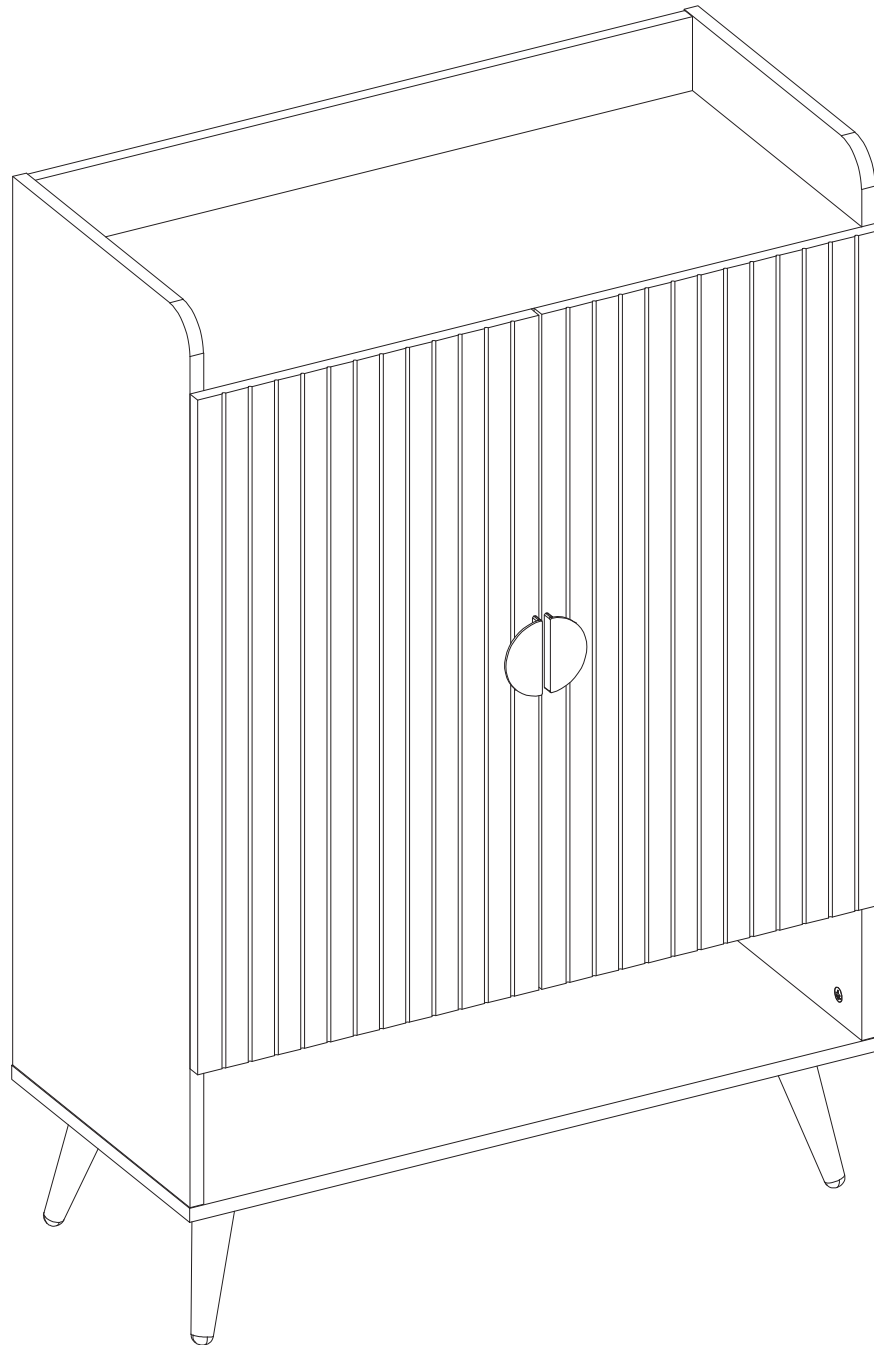

Contact Us

We're here to help you.

Your satisfaction is our top priority. If you encounter any issues with this product, such as missing or damaged parts, we're here to help. Please retain the original packaging and take photos of the packaging and the product, then contact us as soon as possible.

Warm Tips

1. Carefully read these instructions and keep them for future reference.
2. Check the parts list and confirm everything's there before starting assembly.
3. When assembling, put all parts on a soft, smooth surface like a carpet to avoid scratches.
4. Don't fully tighten screws until all parts are confirmed in place to avoid misalignment.

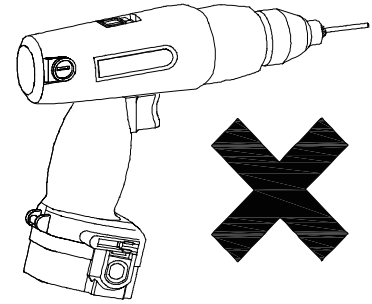
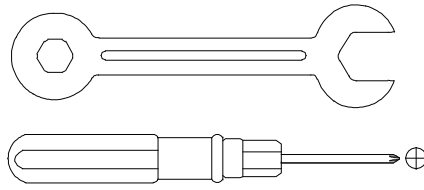
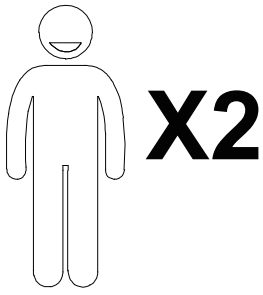

We recommend using hand tools for assembly.

If an electric screwdriver is used, reduce power and torque to avoid damage to the product.

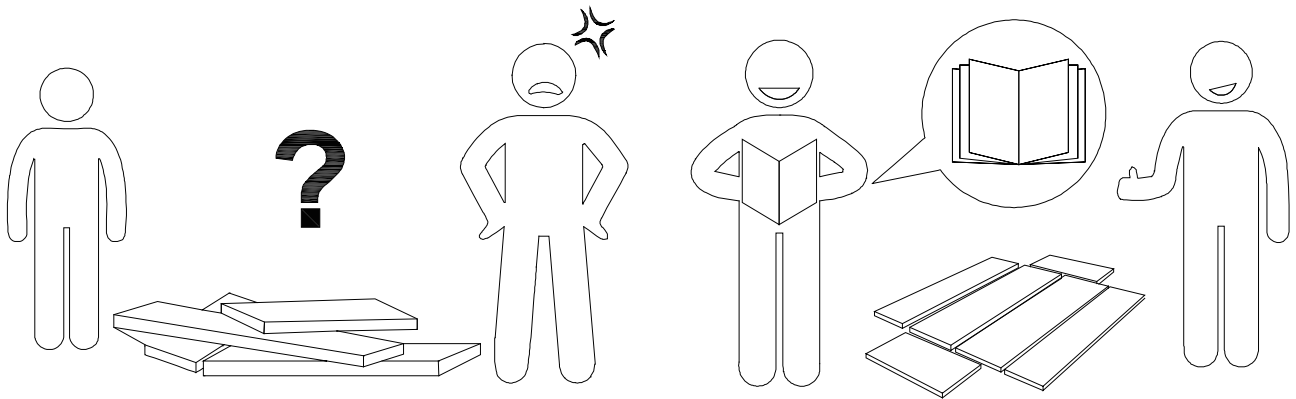

Install the Anti-Tip Straps

Using the anti-tip straps can reduce the risk of tipping over, but can not eliminate it.

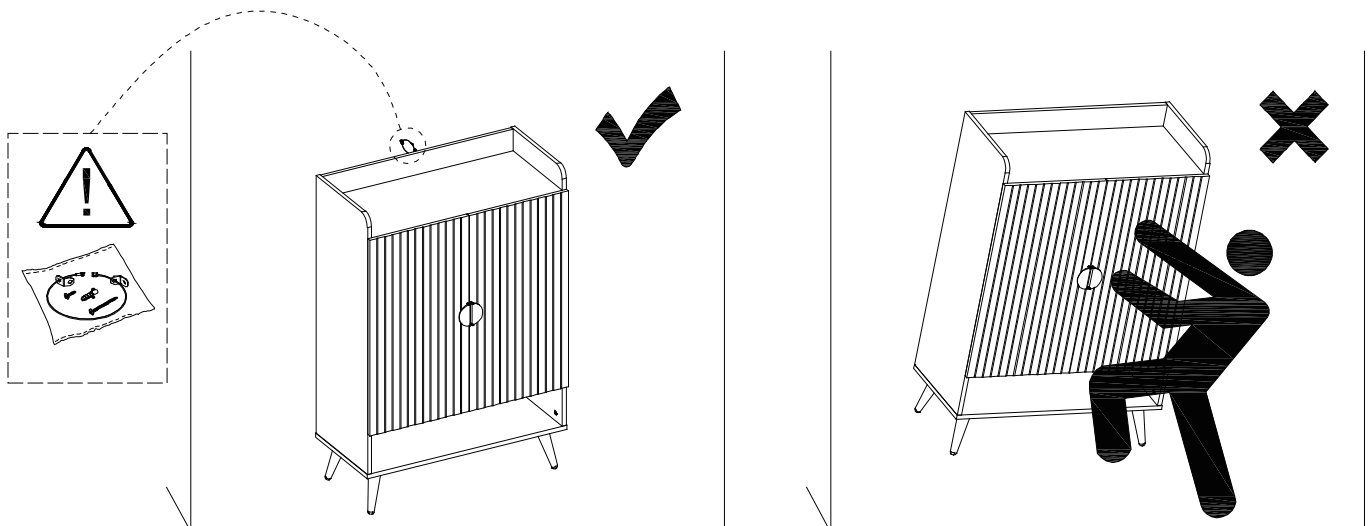

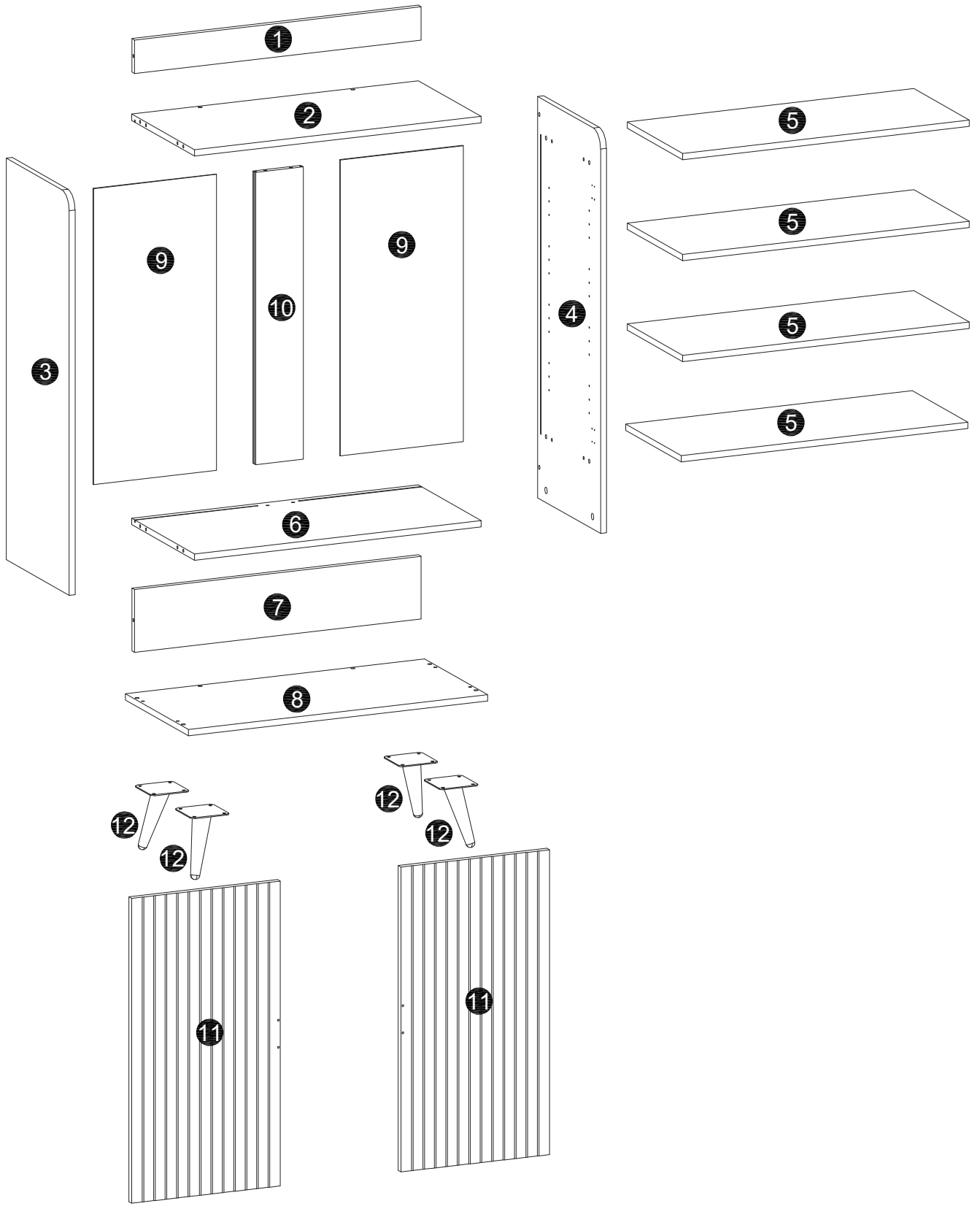



⚠ Caution

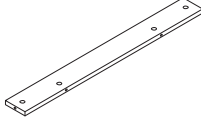
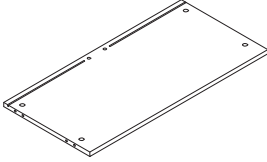
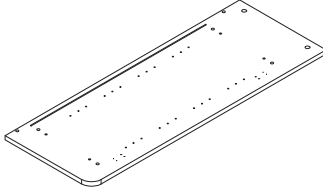
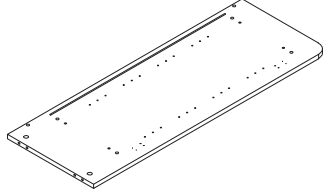
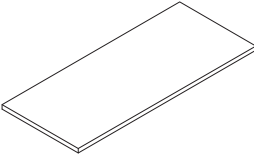
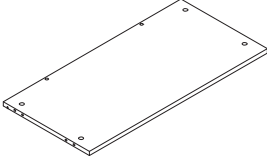
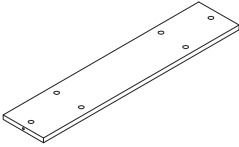
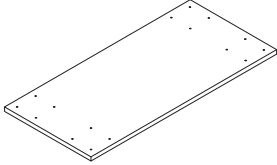
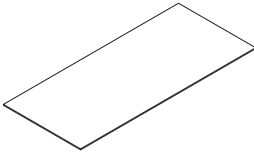
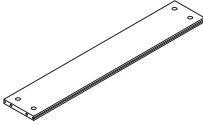
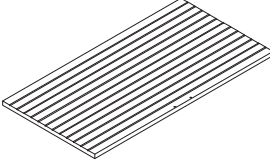
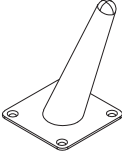

Make sure all parts are included. Most board parts are labeled or stamped on the raw edge. Contact us for a free replacement if you encounter any damaged or missing parts.

Parts List

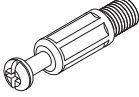
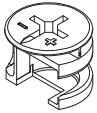
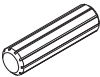
 1 pc	 1 pc	 1 pc	 1 pc
 4 pcs	 1 pc	 1 pc	 1 pc
 2 pcs	 1 pc	 2 pcs	 4 pcs

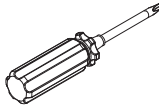
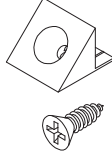
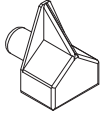
Hardware List

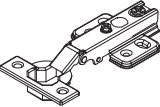
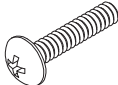
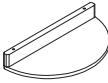
A	B	C	D	E	F	G
 M6x35mm	 Ø15x12mm	 Ø8x30mm	 Ø3.5x14mm	 1 pc	 12 pcs	 16 pcs

H	I	J	K			
 4 pcs	 Ø4x20mm	 2 pcs	 1 pc			

Installation of Cams and Pins

Read each step carefully before starting. Each step of instruction should be performed in the correct order. If these steps are not followed in sequence, assembly difficulties may occur.

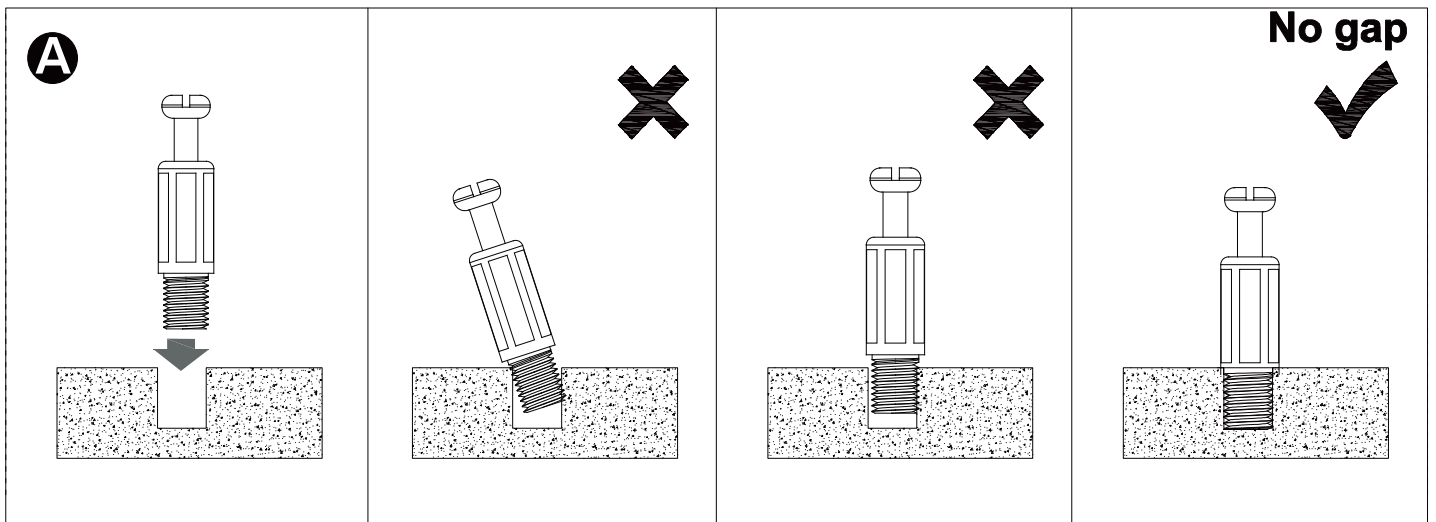
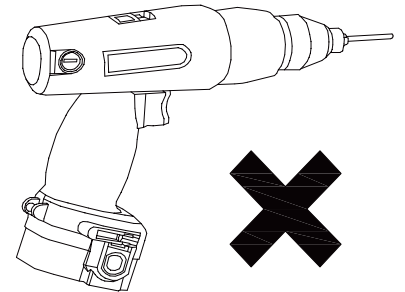

Screw the pin into the hole. Set the cams correctly by aligning the head of the cams with the lock pins. Lock the cam by turning the cam head with a screwdriver until it is tightened. Please do not use an electric screwdriver to assemble the unit.

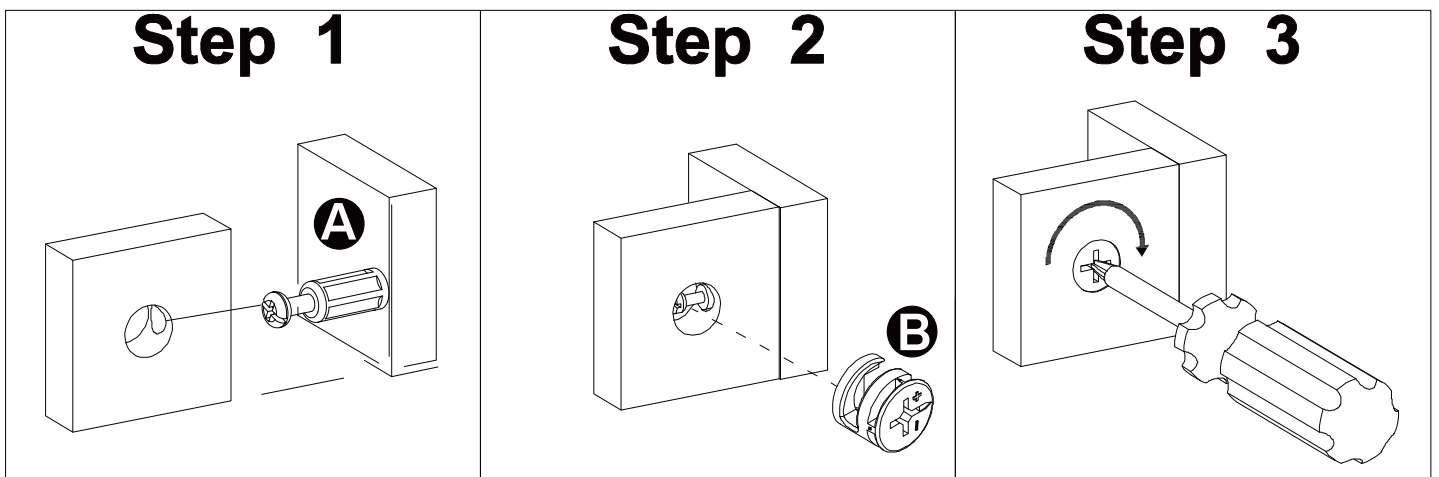

1

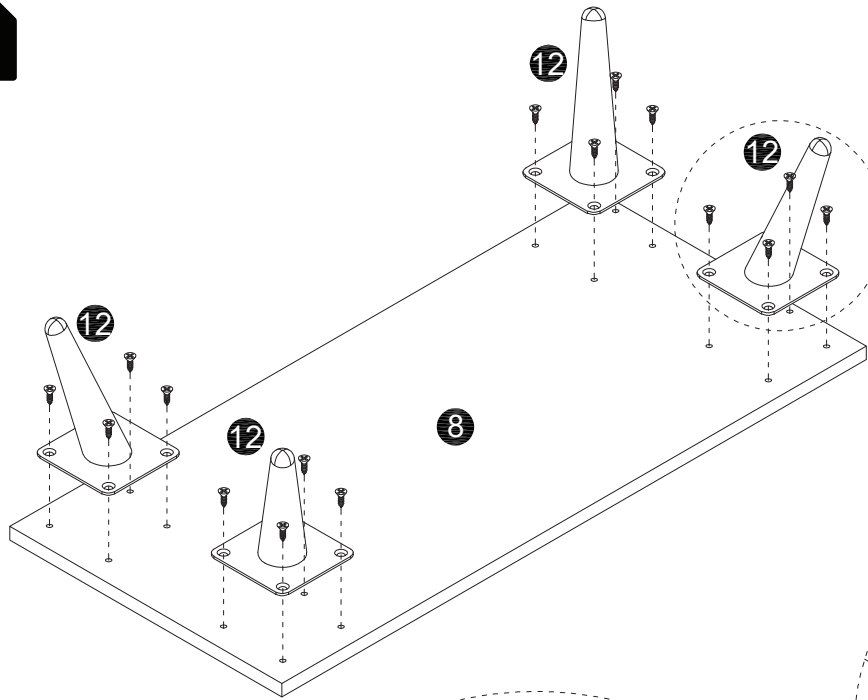

D

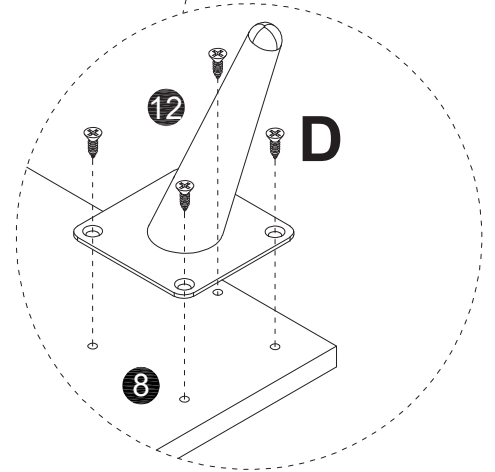
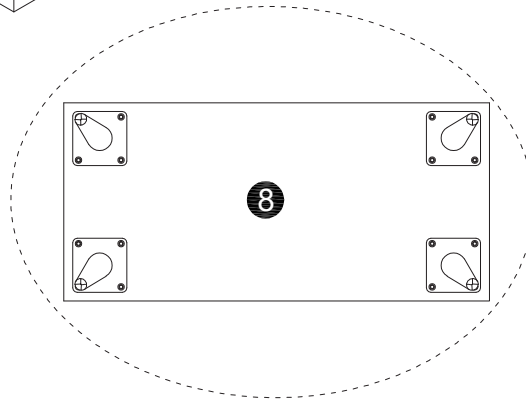
Ø3.5x14mm
16 pcs

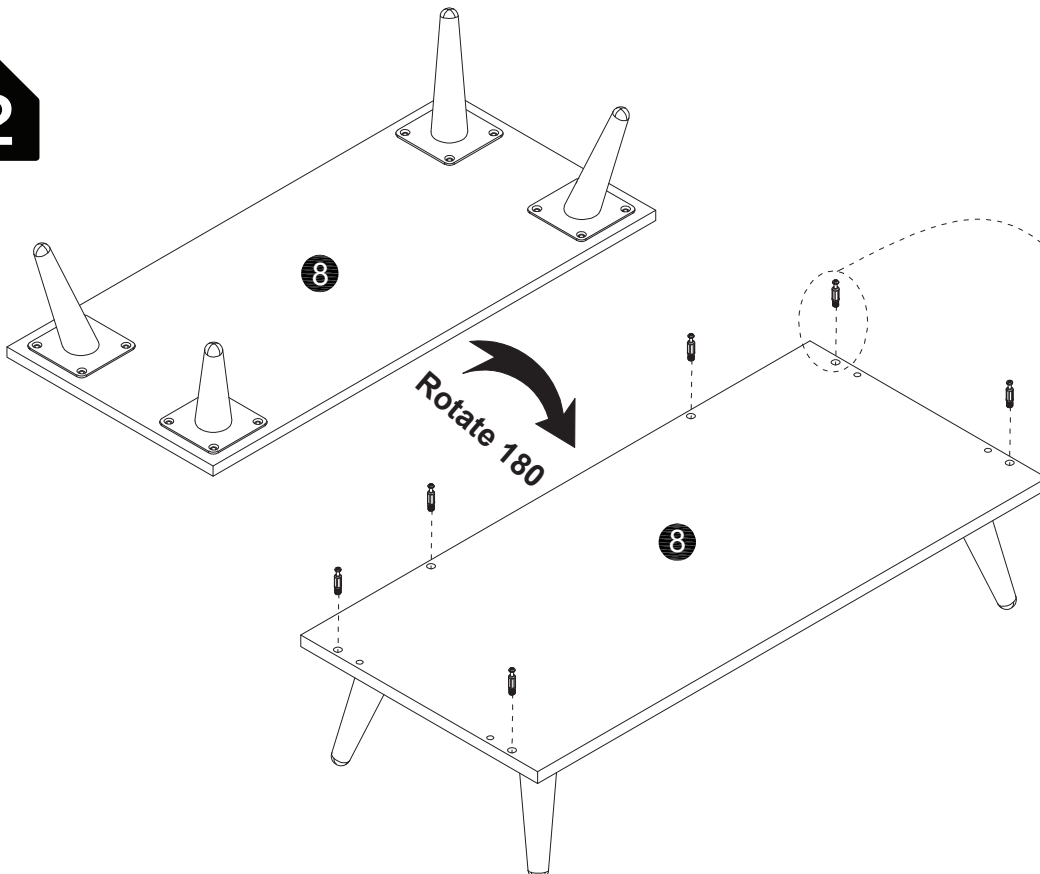

2

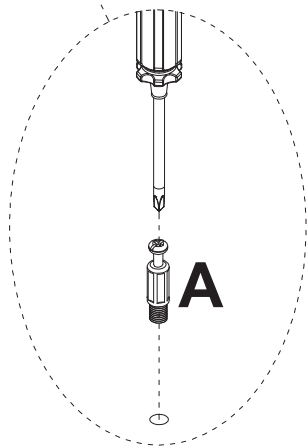

A

M6x35mm
6 pcs

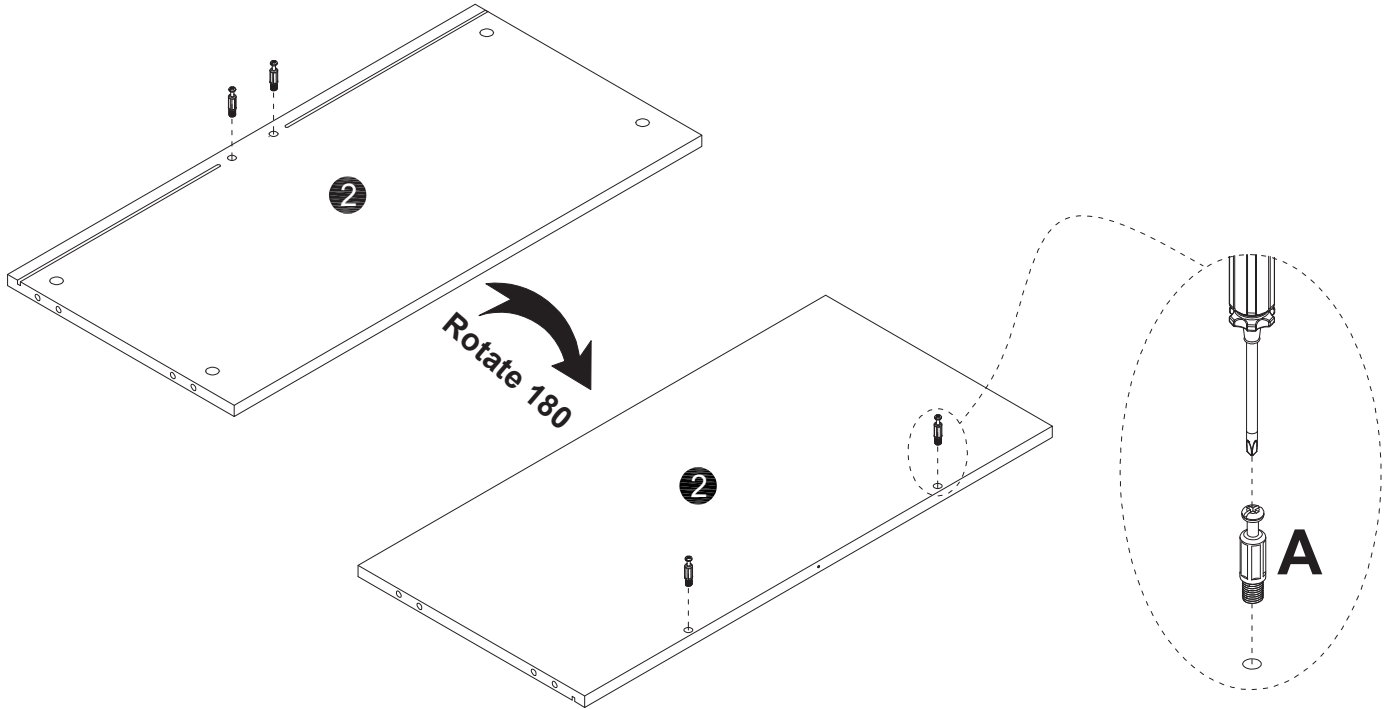

3

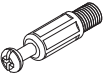

A

M6x35mm
4 pcs

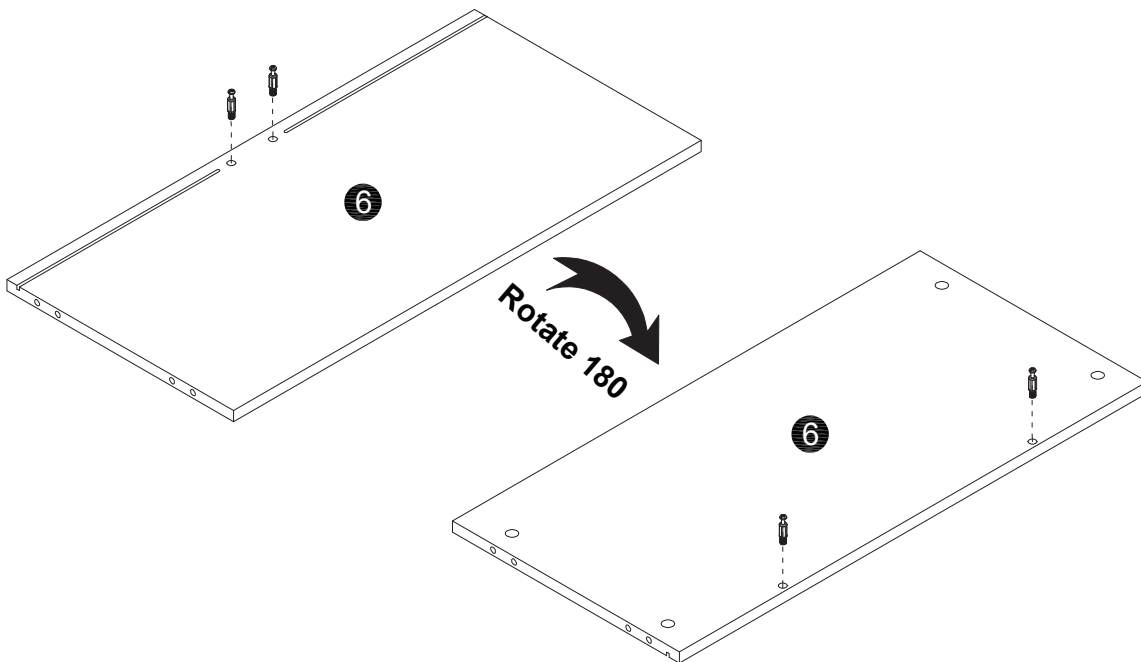
4

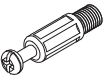

A

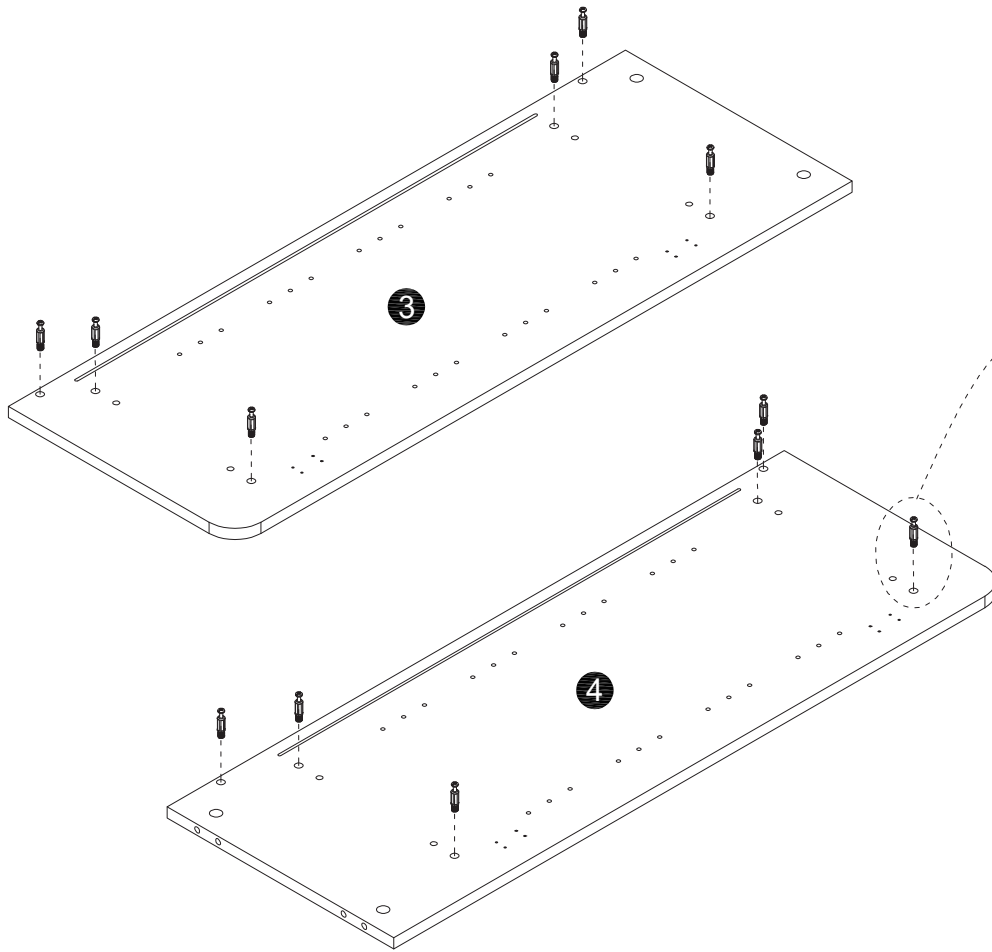
M6x35mm
4 pcs

5



A

M6x35mm
12 pcs

6

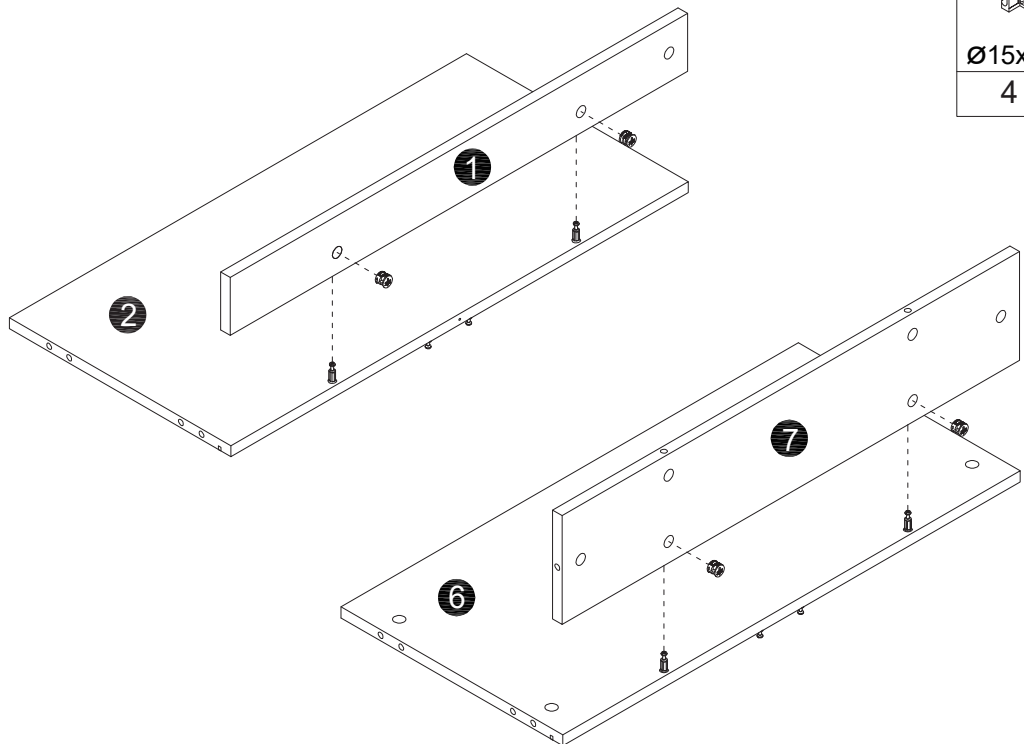
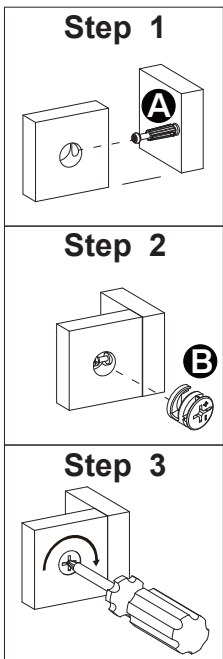

B

Ø15x12mm
4 pcs

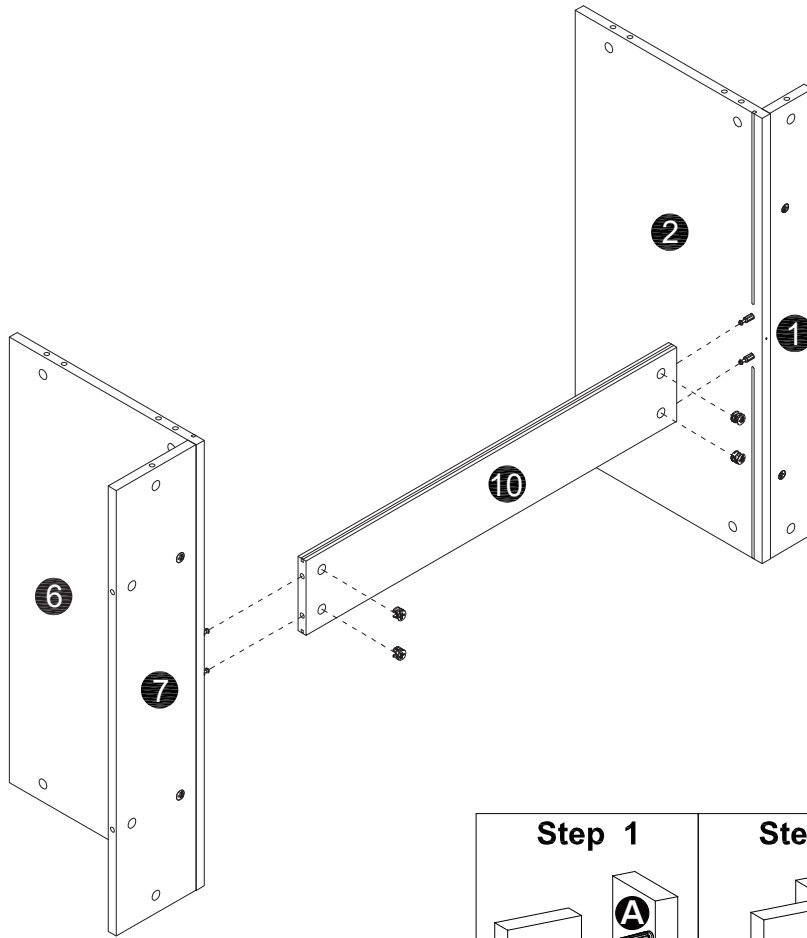
7

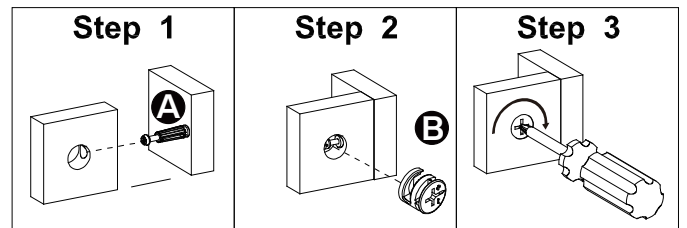

B

Ø15x12mm
4 pcs

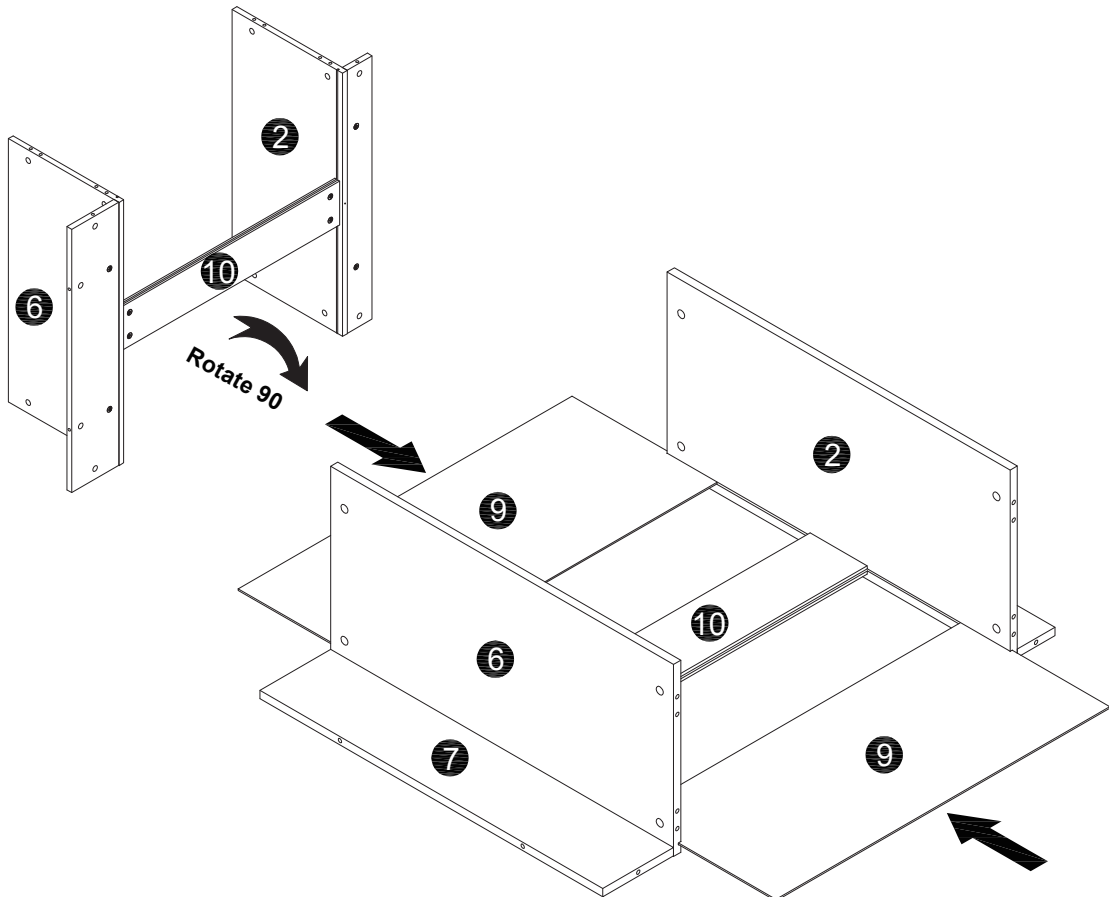

8

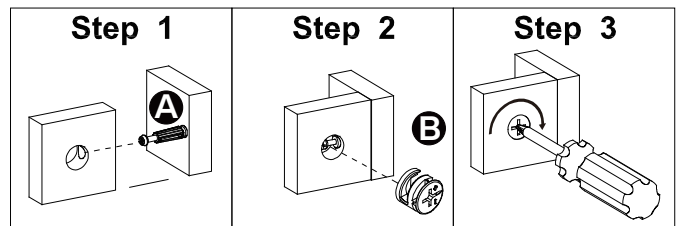
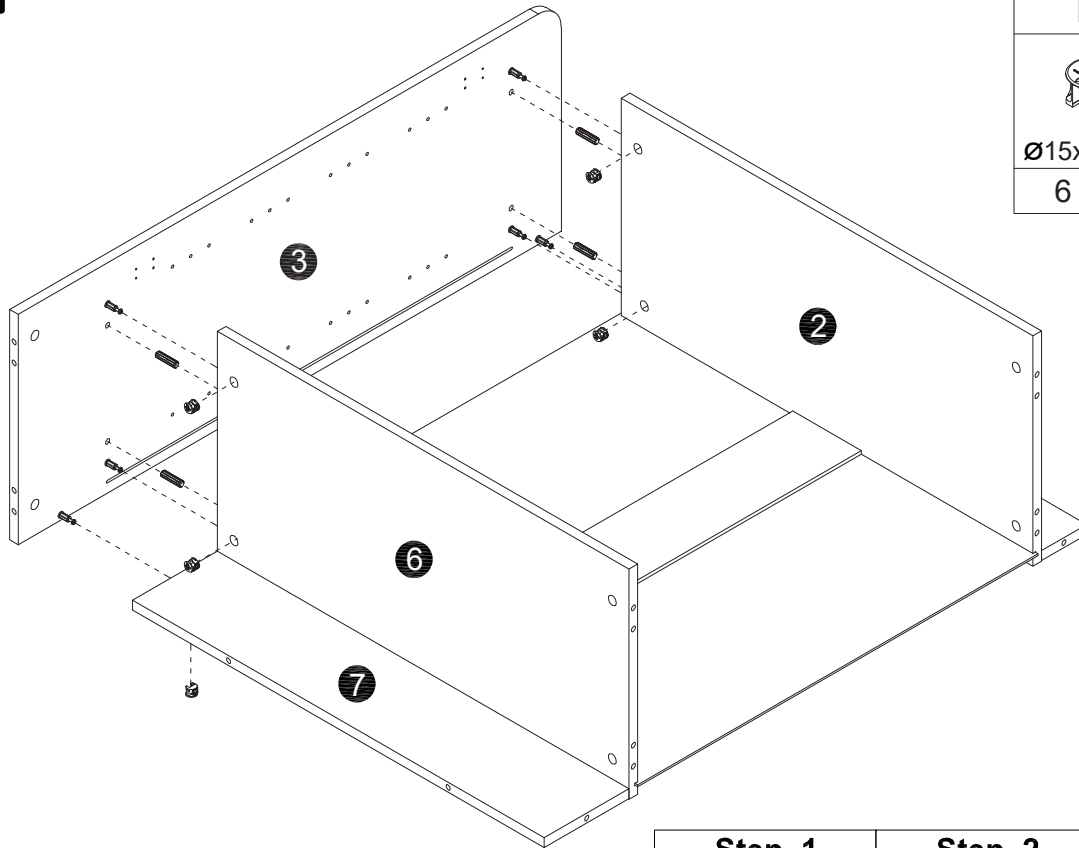

9



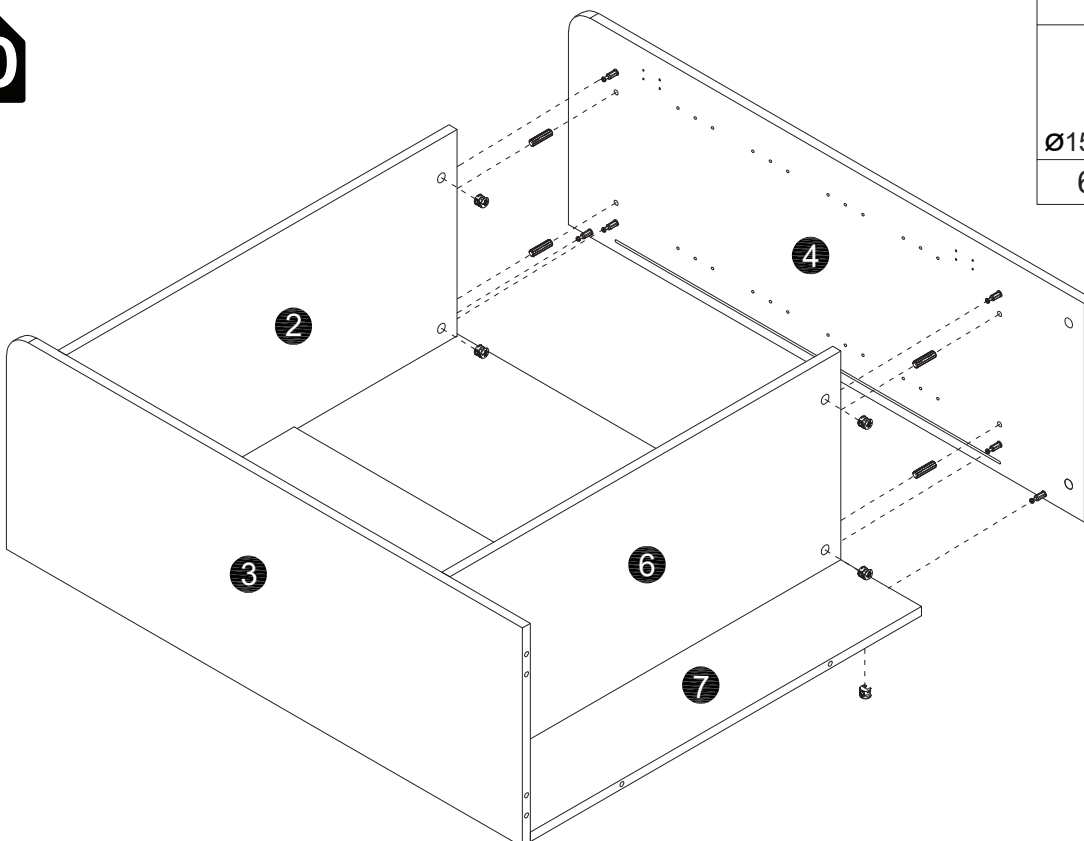

10

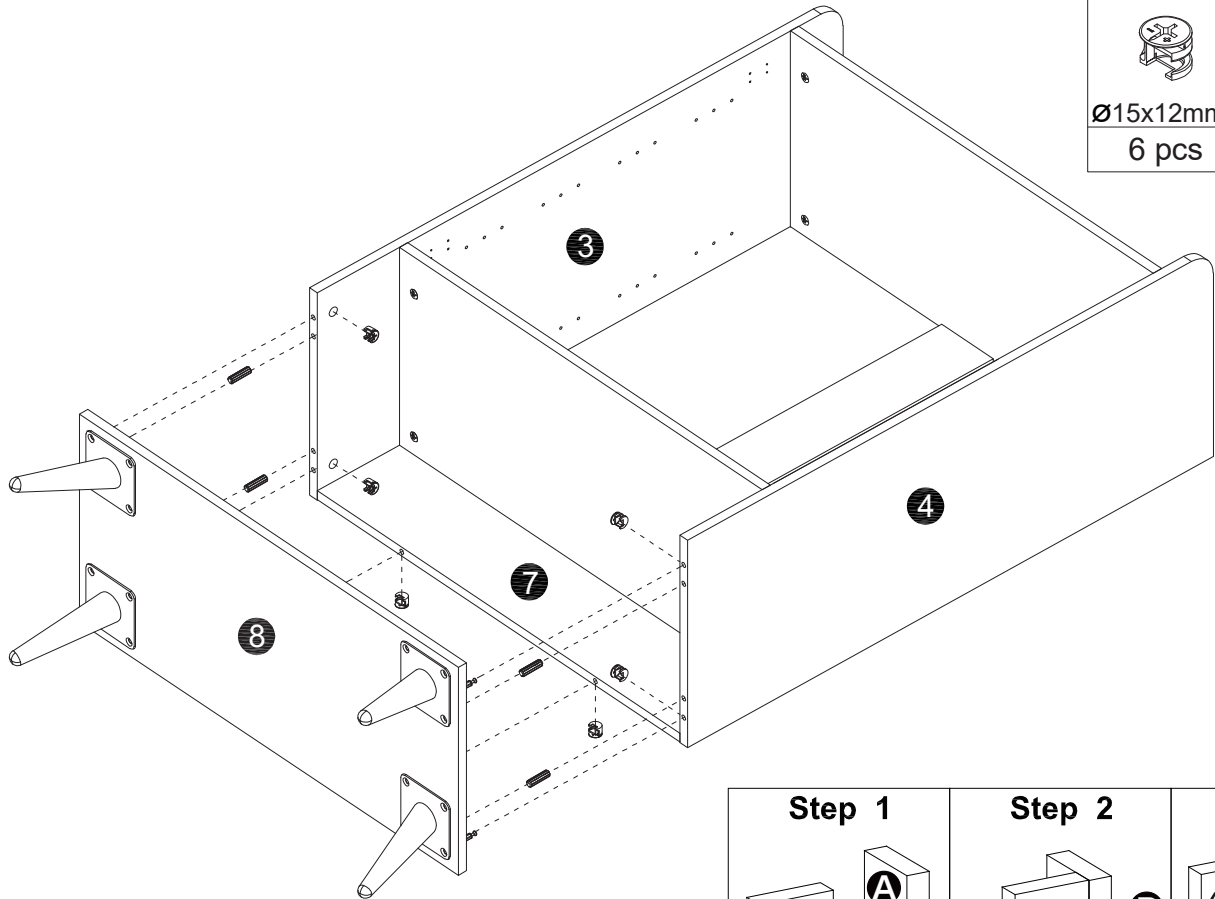

11



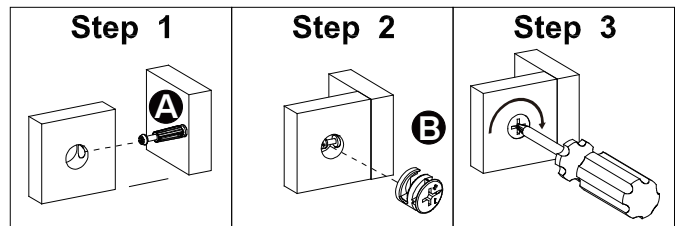

B	C
	
Ø15x12mm	Ø8x30mm
6 pcs	4 pcs

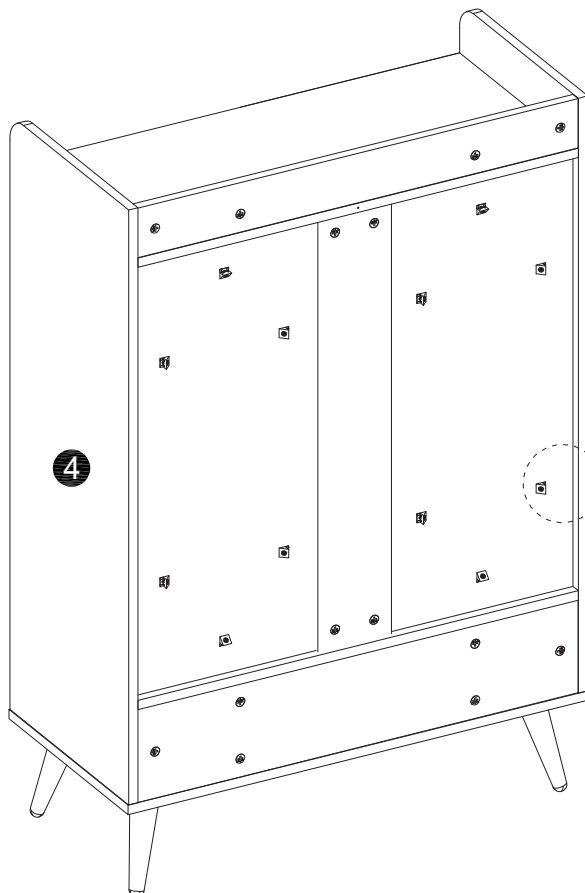

12



F
 
12 pcs

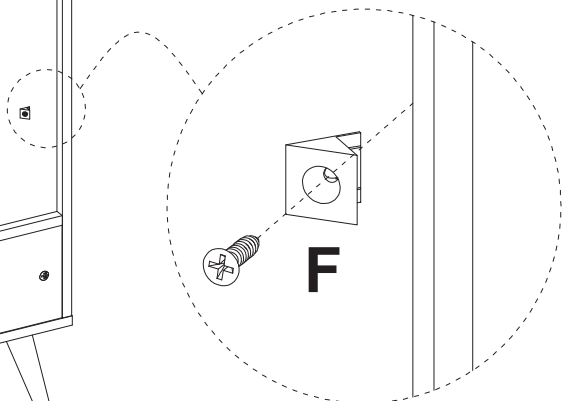

13

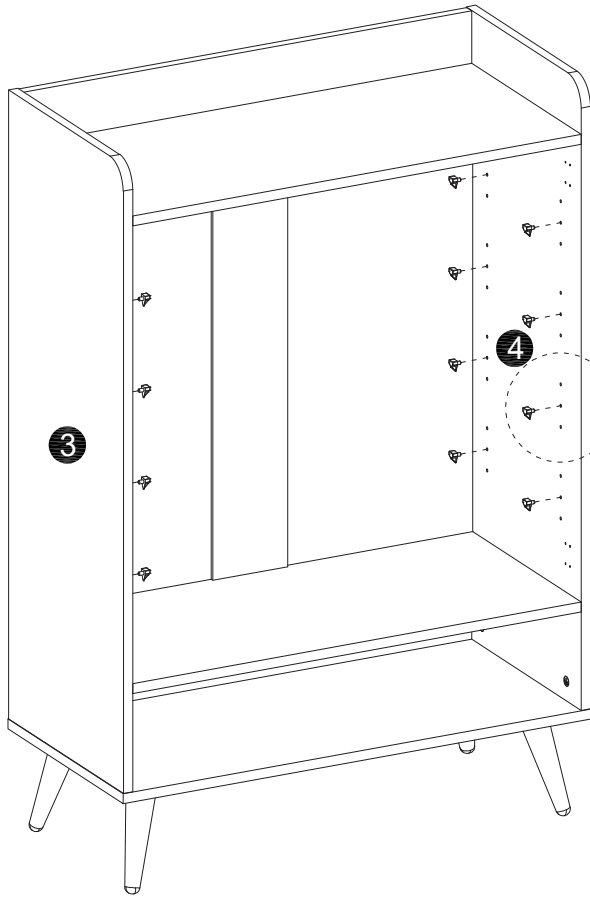

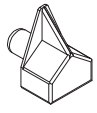
G

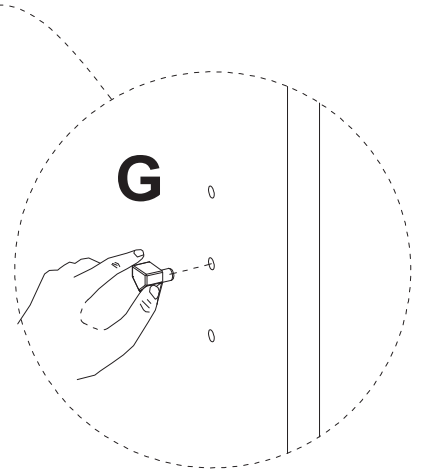
16 pcs

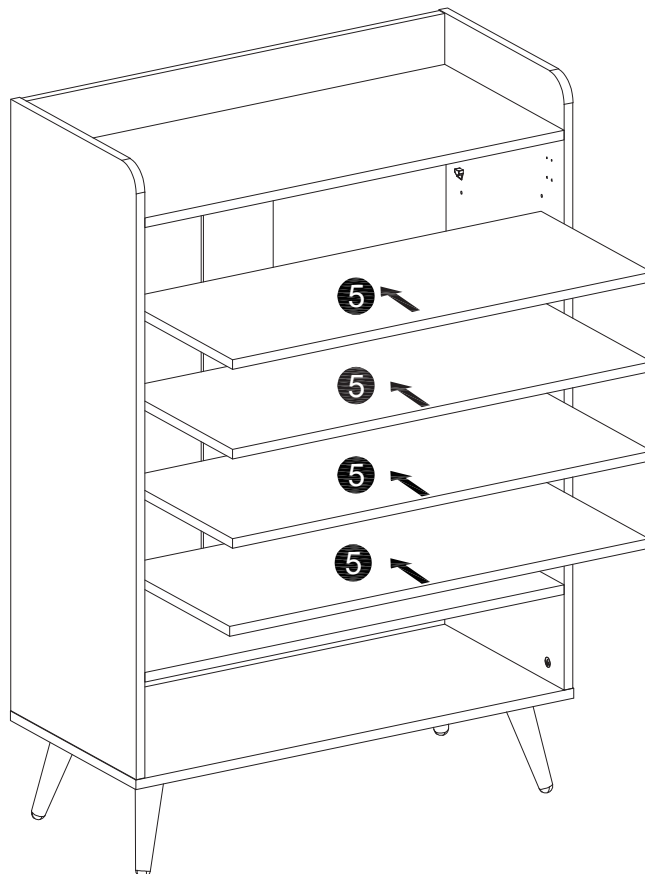

14

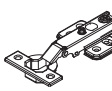
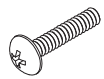
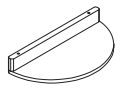

15

D	H	I	J
			
Ø3.5x14mm		Ø4x20mm	
8 pcs	4 pcs	4 pcs	2 pcs

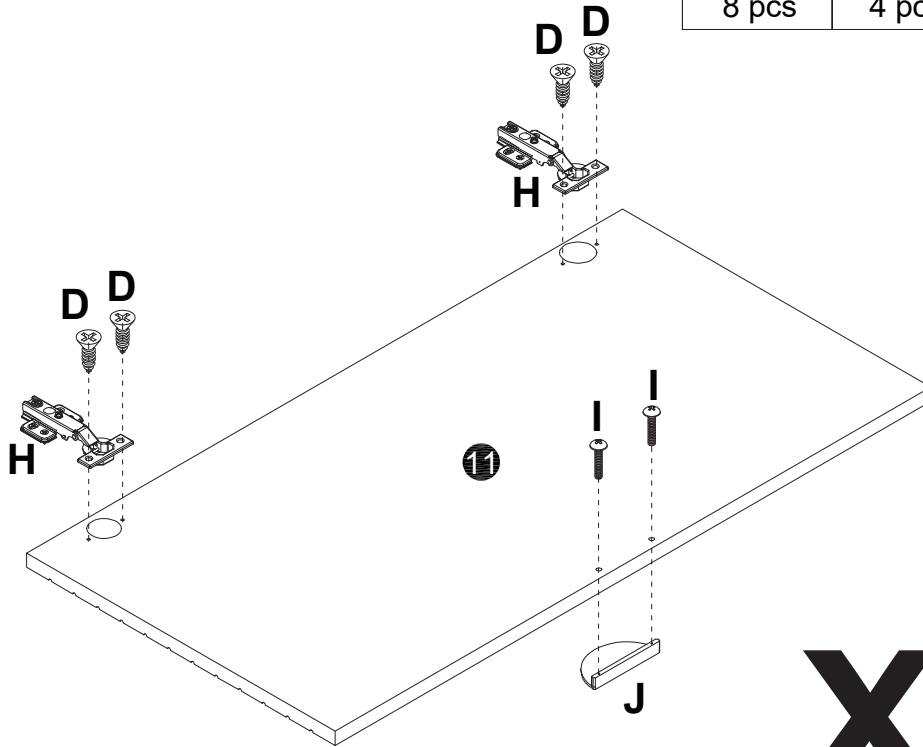

x2

16

D

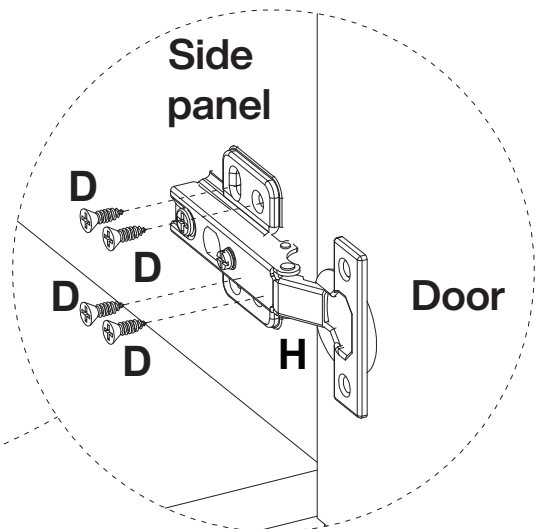
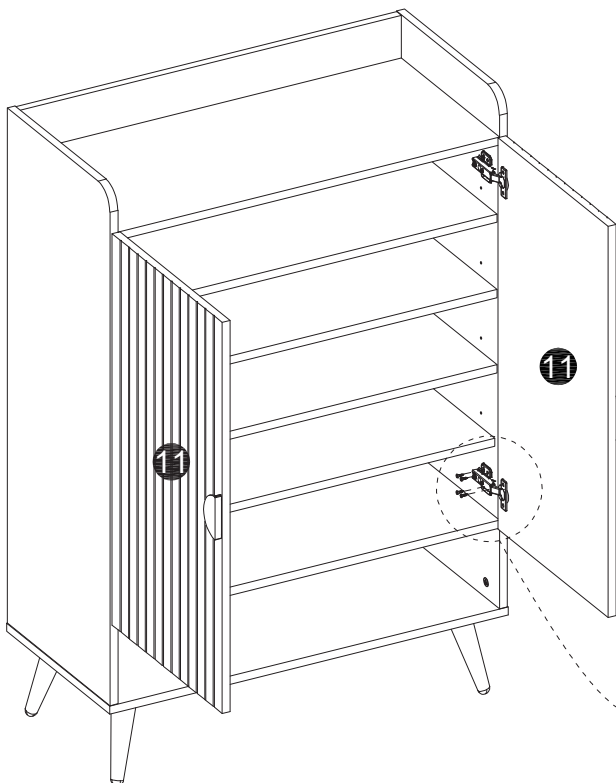
Ø3.5x14mm
16 pcs



To prevent the door hinge from falling off, please install 4 screws

Step 1

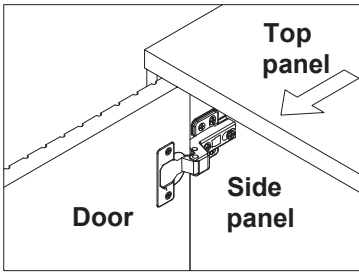
Open the door.



ADJUST YOUR DOORS TO MAKE THE GAPS MORE EVEN (OPTIONAL).

Step 2

Adjust the door panel to be flush with side panel and top panel edge.

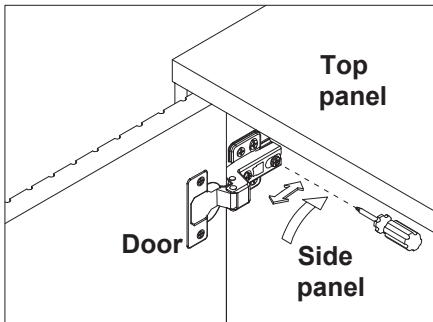

Loosen the screw indicated a little, adjust the hinge to the right position (see step 2a & 2b), then tighten the screw.

Step 2a MOVE DOOR OUT

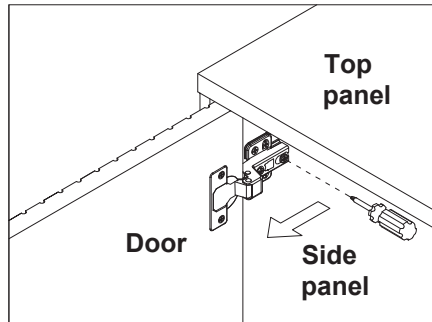
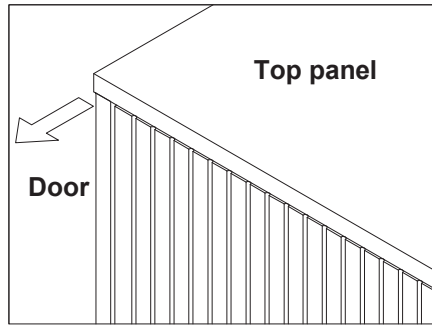

Pull the hinge forward a little.

Step 2b MOVE DOOR IN

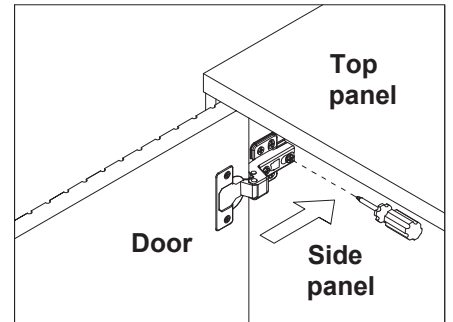
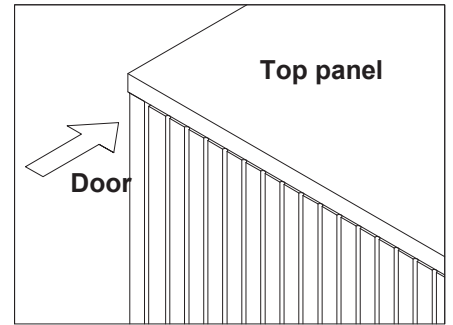

Push the hinge back a little.

Step 3

Adjust the gap between the door panel and the side panel.

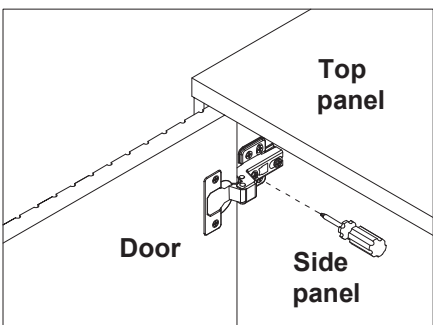

Loosen or tighten the screw indicated a little to adjust the gap between the door panels, adjust the hinge to the right position (see step 3a & 3b).

Step 3a MOVE DOOR LEFT

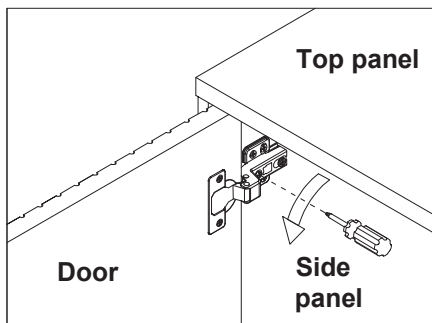
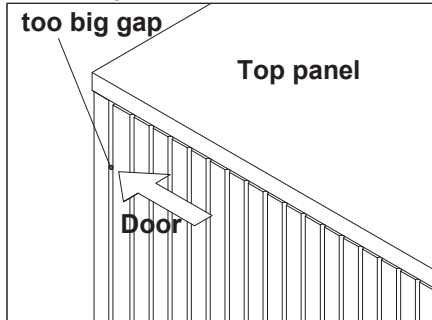

Turn the screw clockwise a little as shown to make the gap smaller

Step 3b MOVE DOOR RIGHT

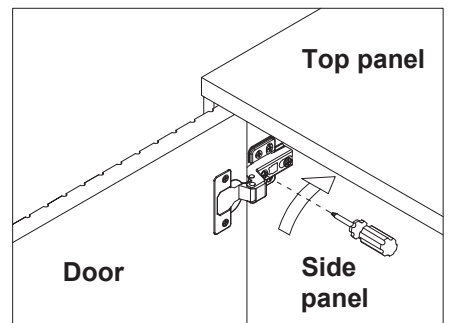
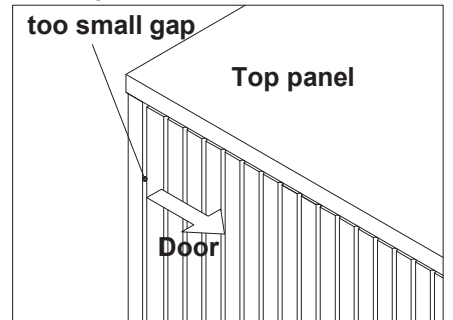

Turn the screw counterclockwise a little as shown to make the gap bigger

17

K

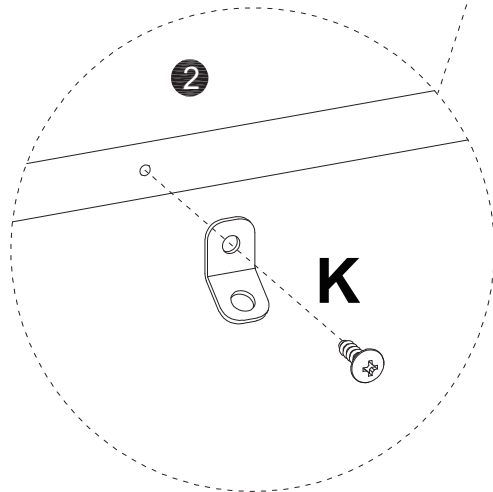
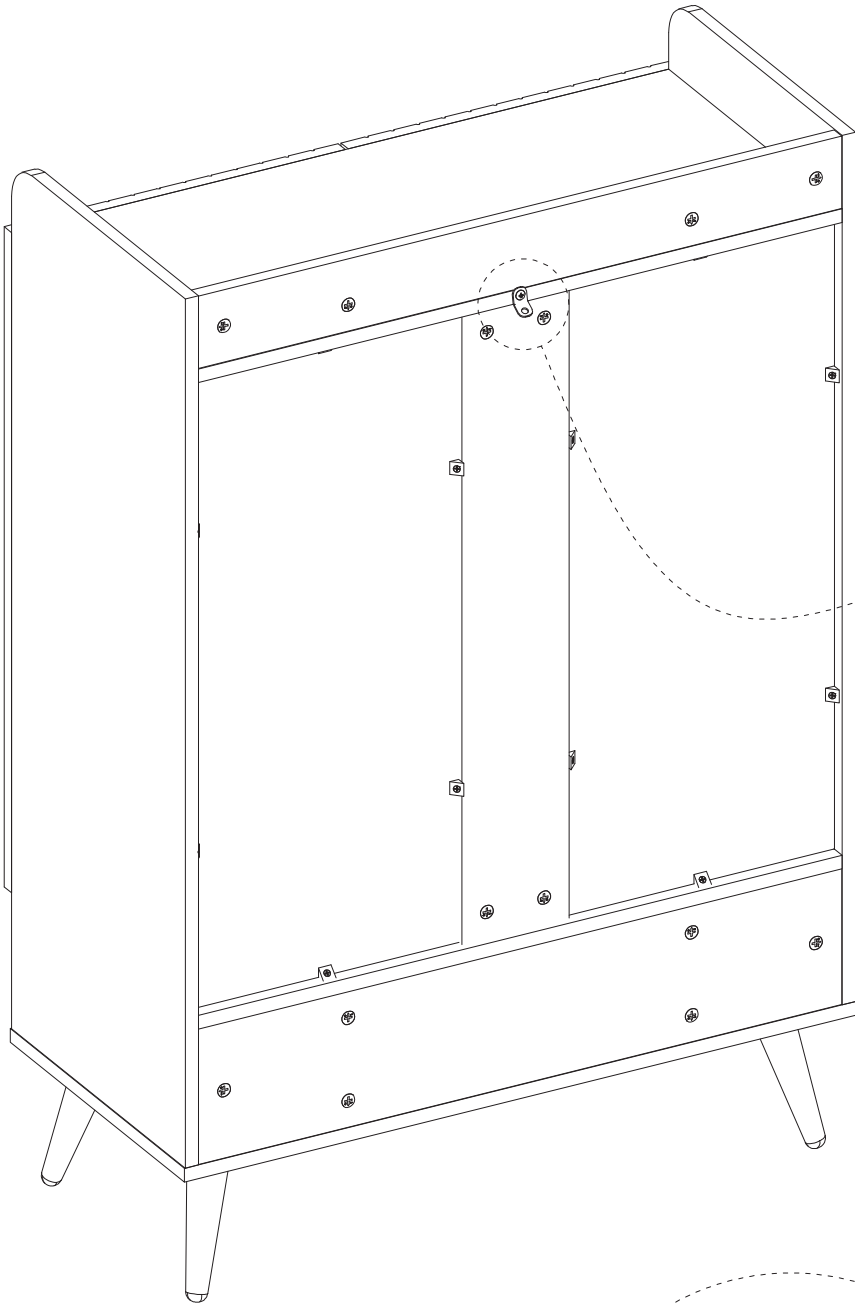
1 pc

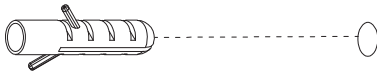

Wall

Step1



Step2

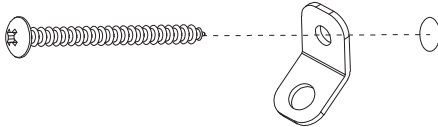

Step3

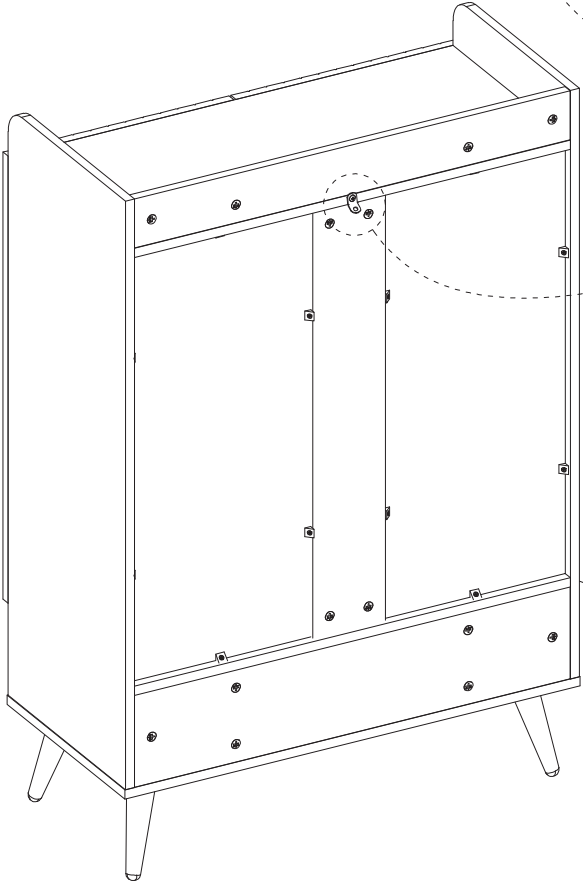
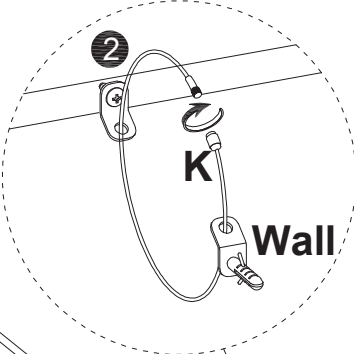

Thank you for your support!

