

# Assembly Instruction

## Assembly mode A

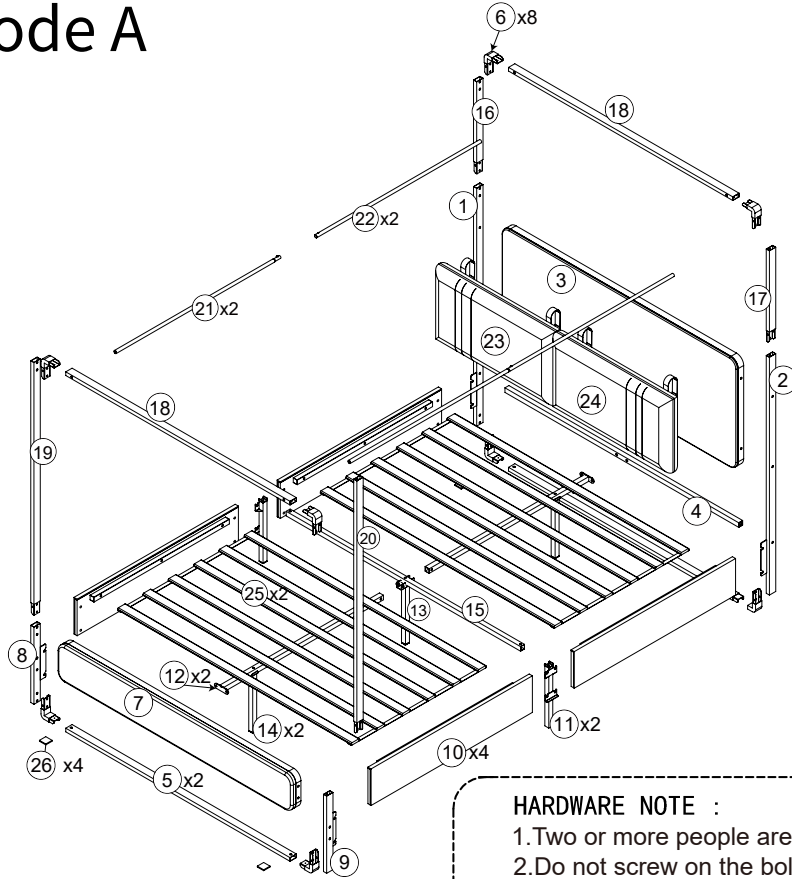

### Important Note

#### HARDWARE NOTE :

1. Two or more people are required for assembly
2. Do not screw on the bolts too tight unless the installation is done. Make sure all bolts are tightly screwed before you use it.

## Assembly mode B

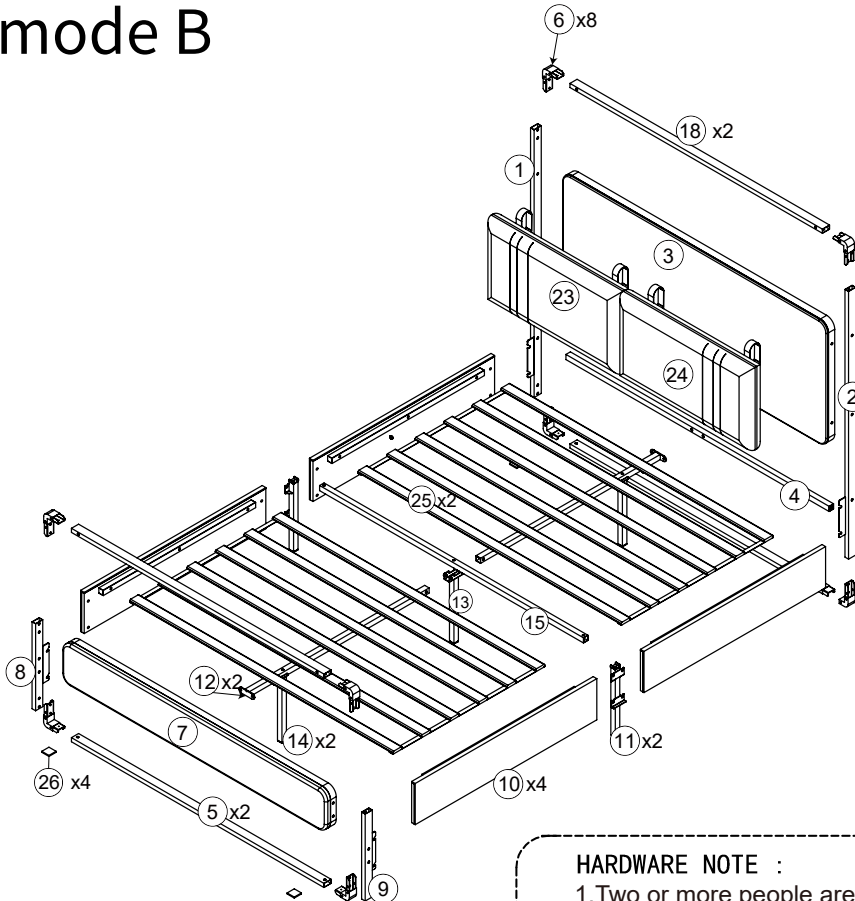

### Important Note

#### HARDWARE NOTE :

1. Two or more people are required for assembly
2. Do not screw on the bolts too tight unless the installation is done. Make sure all bolts are tightly screwed before you use it.

# Components

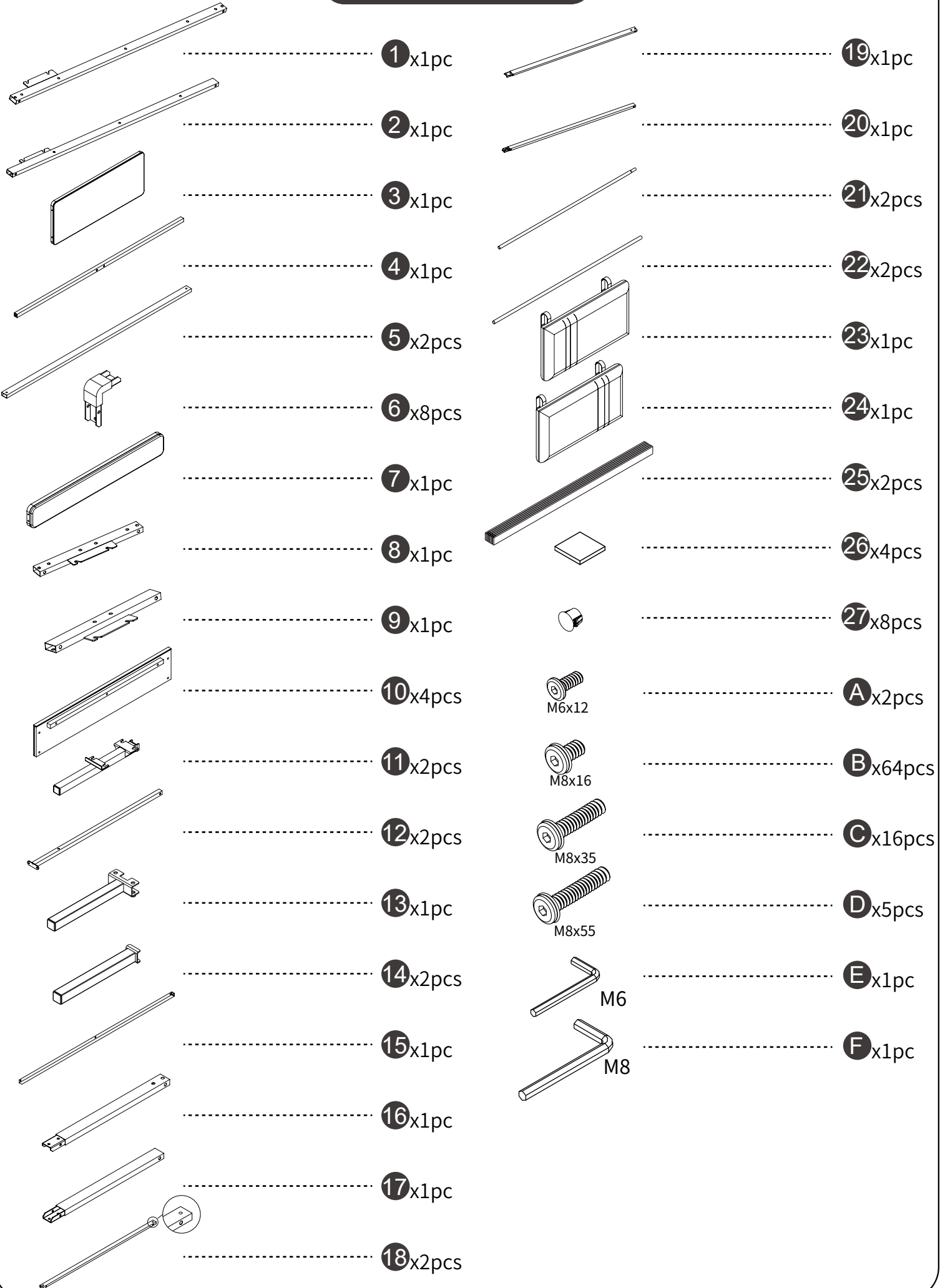

1

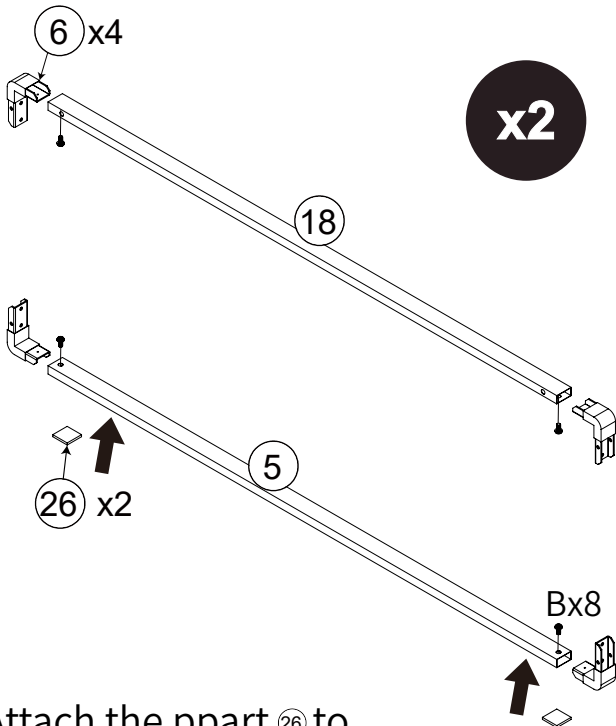

x2

Attach the part 26 to the bottom of part 5

B	 M8x16	8
---	---	---

2

Assemble part 5 first with parts 1 and 2, and part 3 and 4.

! The screw is not locked in this step

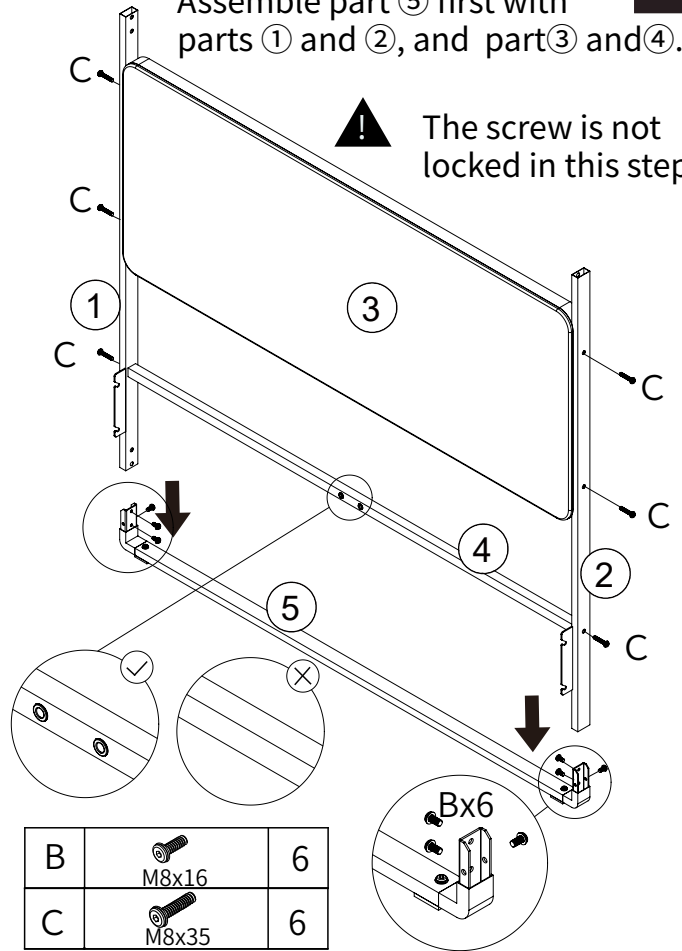

B	 M8x16	6
C	 M8x35	6

3

First assemble part 5 with parts 8 and 9, then assemble part 7.

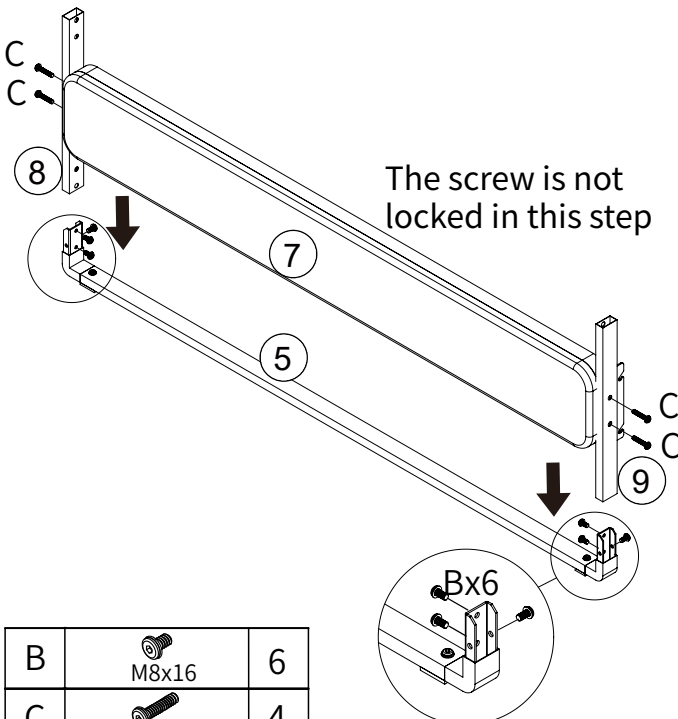

The screw is not locked in this step

B	 M8x16	6
C	 M8x35	4

4

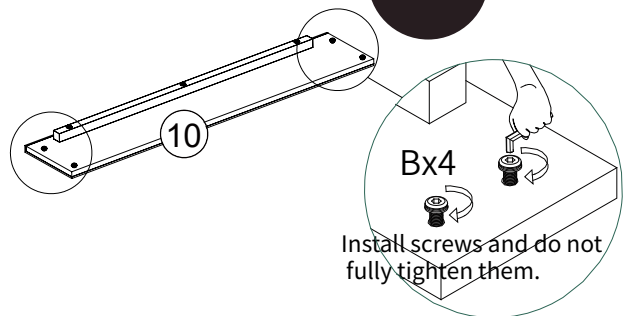

Install screws and do not fully tighten them.

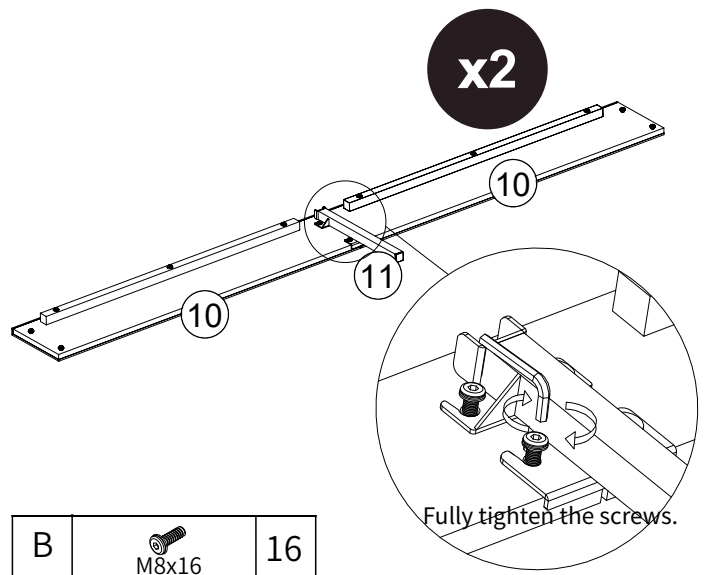

Fully tighten the screws.

B	 M8x16	16
---	--	----

5

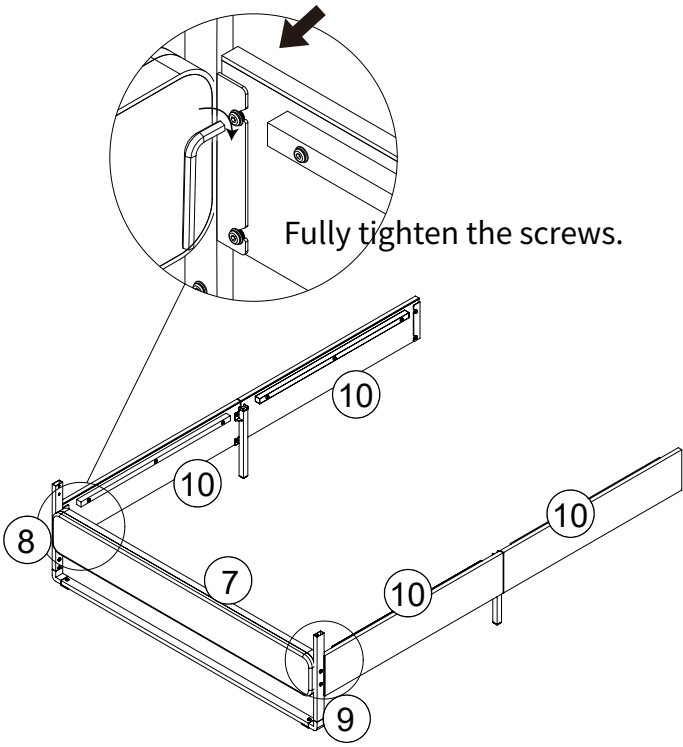

6

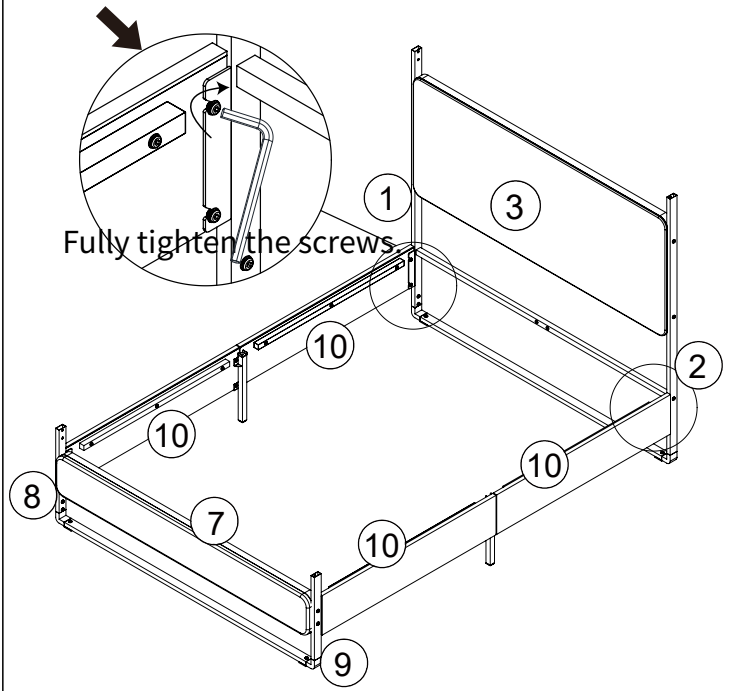

7

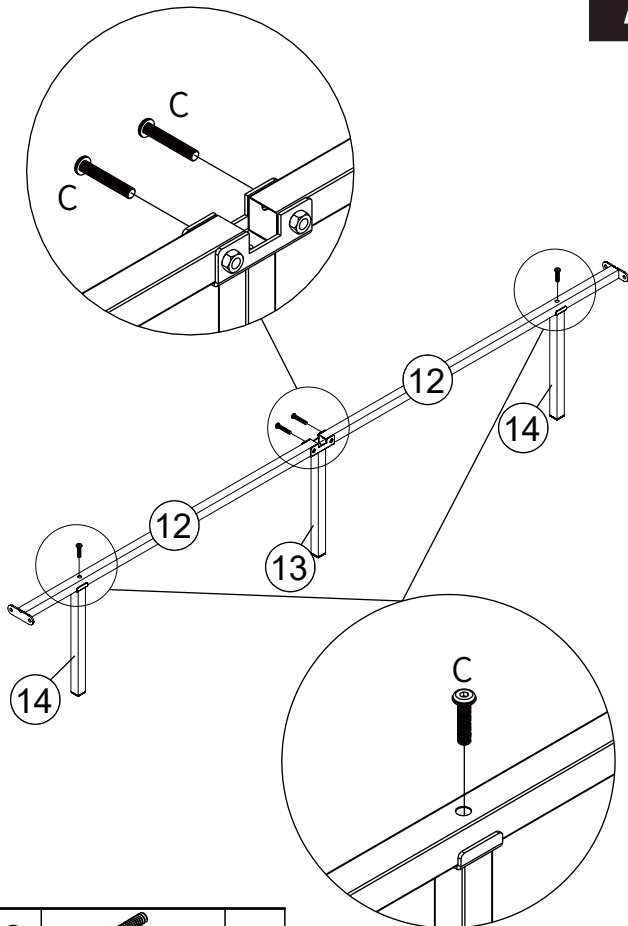

C		4
M8x35		

8

The second assembly

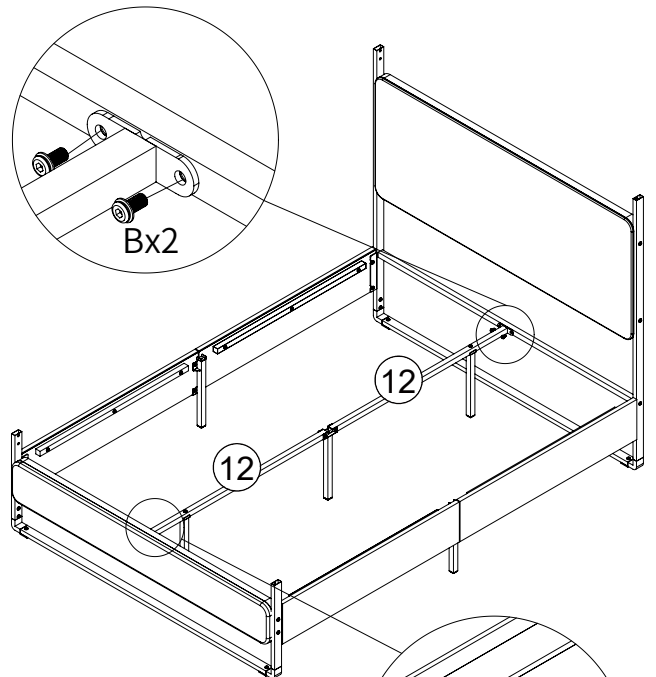

First assembly

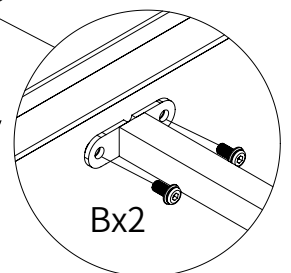

B		4
M8x16		

9

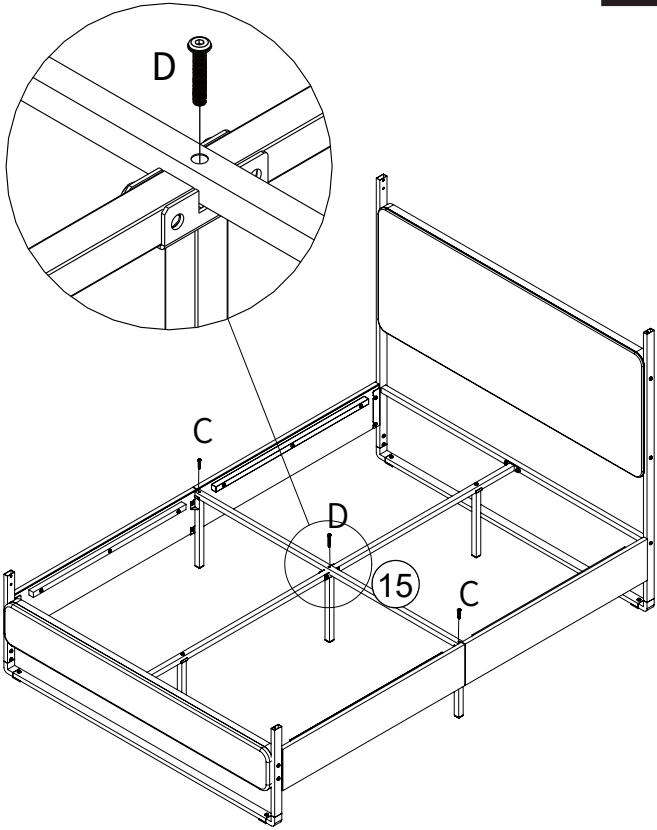

C	M8x35	2
D	M8x55	1

10

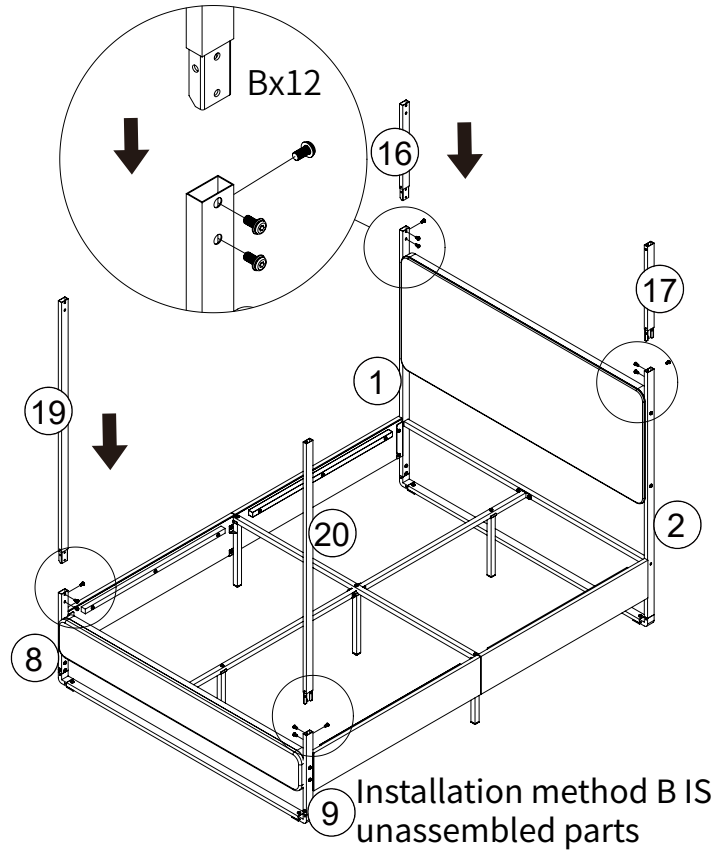

B	M8x16	12
---	-------	----

Installation method B IS unassembled parts 16 17 19 20.

11

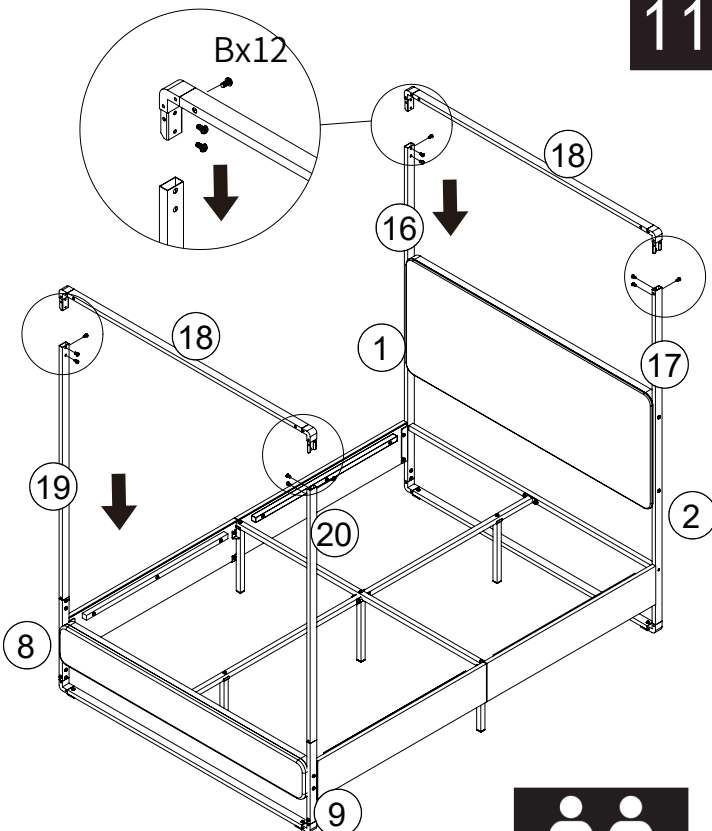

Installation method B is to assemble part 18 with parts 1, 2, 8 and 9.

B	M8x16	12
---	-------	----



12

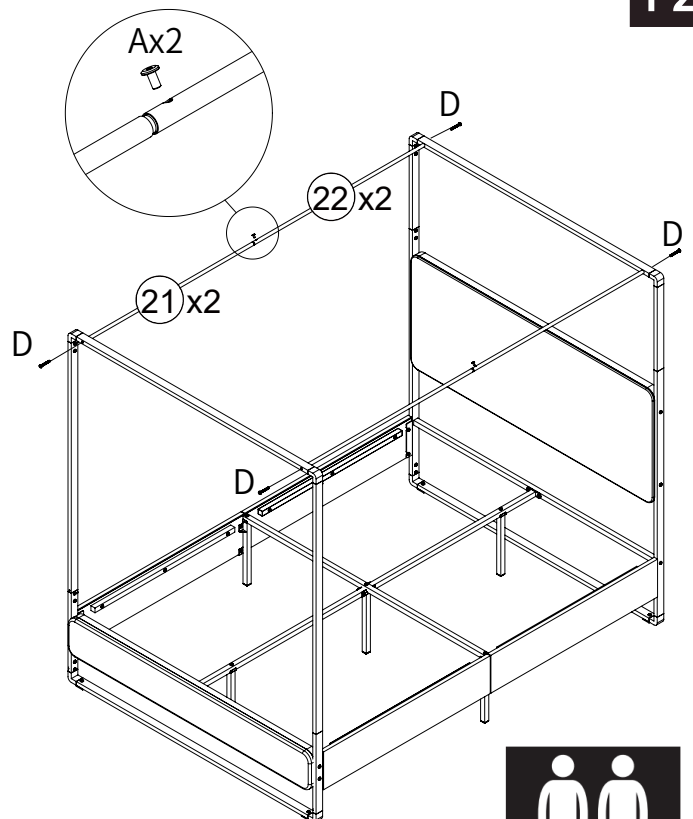

A	M6x12	2
D	M8x55	4



13

Remove the soft bag from the PE bag and assemble using Velcro on the back

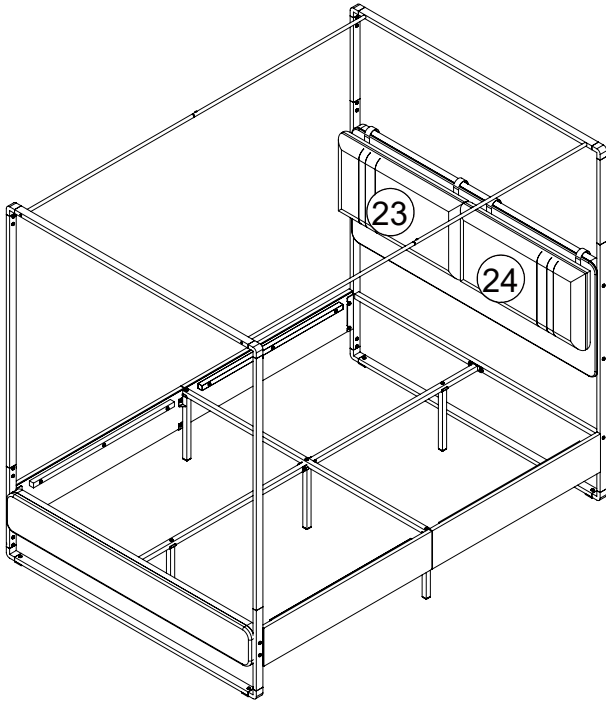

14

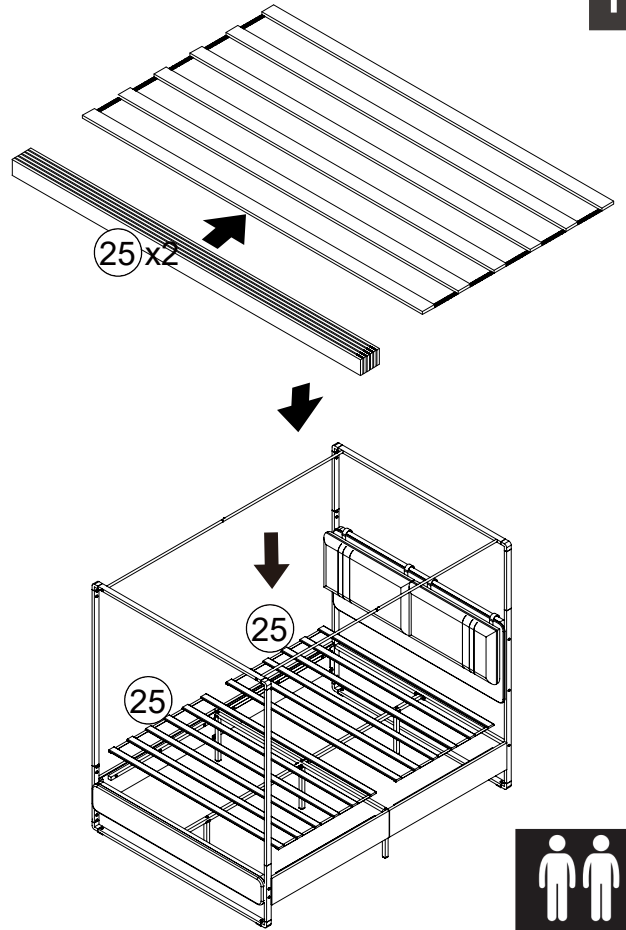

### Assembly mode A

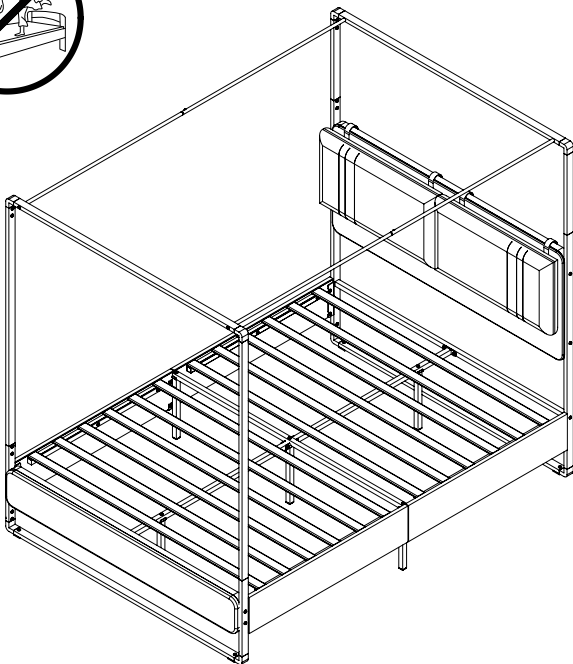

Installation Complete

### Assembly mode B

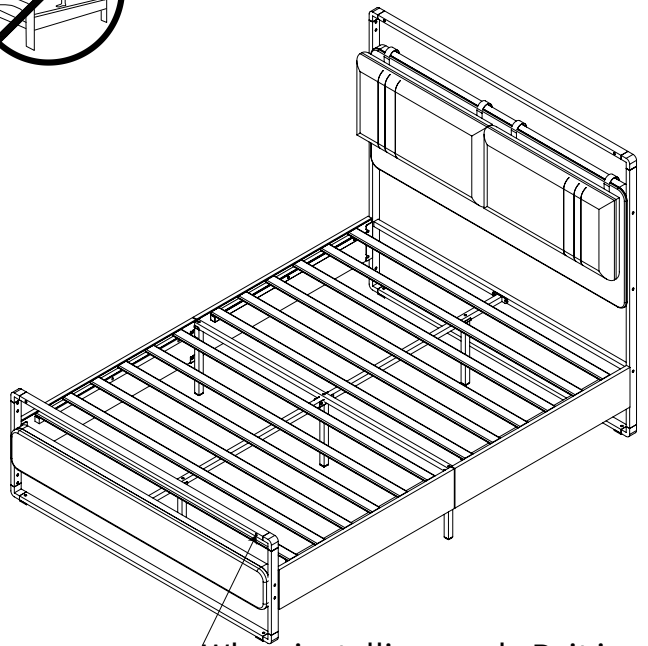

When installing mode B, it is necessary to install Part 27 to block the hole .

Installation Complete