

Exchange Lounge Chair 2.0

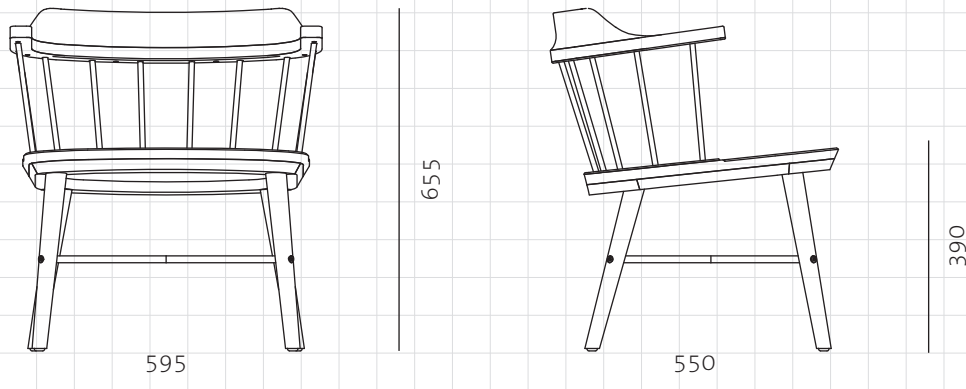

CODE
DIMENSIONS

EX-S111-R2
W595 x D550 x H655mm
Seating height: 390mm

NET WEIGHT
ENVIRONMENT
MATERIALS

8.5 kg
Indoor
Solid wood frame, wood veneer seat, steel black powder coat matt
*Please refer to website or contact your local representative for complete material swatches.

SHIPPING

Package	Assembled		
Package Qty	1 pcs/box		
Packaging	Measurement (mm)	Volume (cbm)	Gross Weight (kg)
FCL	W660 x D615 x H740	0.30	13.24
LCL/AIR	W680 x D635 x H835	0.36	18.26