

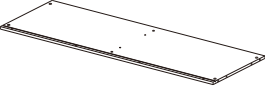

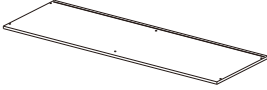

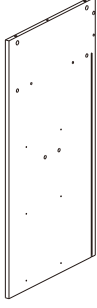

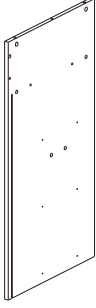

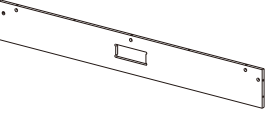
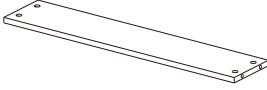
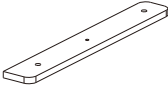
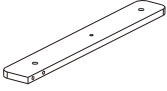

# Wooden Dresser with LED Light

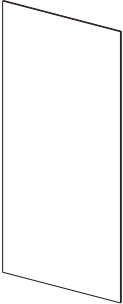
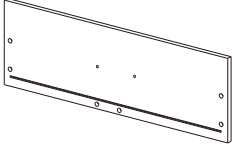
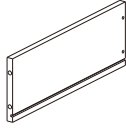
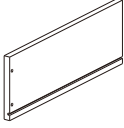

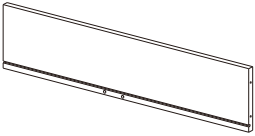

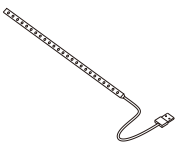
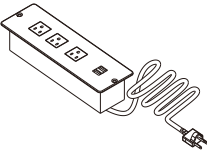
# BOARD IDENTIFICATION

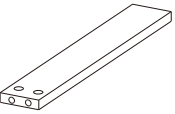
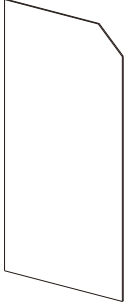
				
<b>Ax1</b>	<b>Bx1</b>	<b>Cx1</b>	<b>Dx1</b>	<b>Ex1</b>
				
<b>Fx1</b>	<b>Gx2</b>	<b>Hx1</b>	<b>Ix1</b>	<b>Jx1</b>
				
<b>Kx2</b>	<b>Lx6</b>	<b>Mx6</b>	<b>Nx6</b>	<b>Ox6</b>
				
<b>Px6</b>	<b>Qx2</b>	<b>Rx1</b>	<b>Sx1</b>	<b>Tx5</b>
				
<b>Ux6</b>	<b>Vx2</b>			

# BOARD IDENTIFICATION

## Installation of Eccentric Wheel Nut Set

1

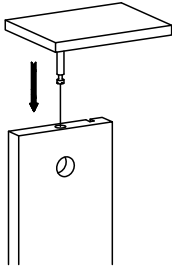

Screw the end of cambolt on the board, find the corresponding board and insert the other end.

2

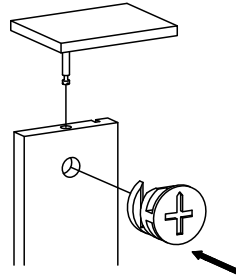

Stuff the camlock into the round hole. The arrowpoints to the cambolt.

3

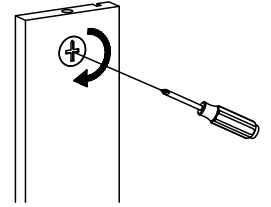

Turn clockwise about 180° to lock the plate.

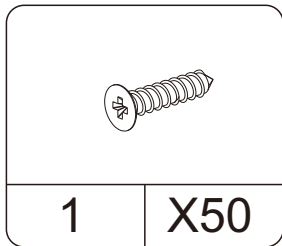

Screws  
M4X10

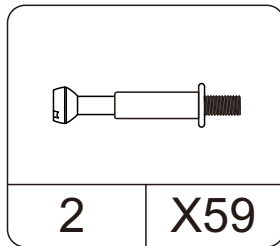

Cam bolt  
Ø6X18

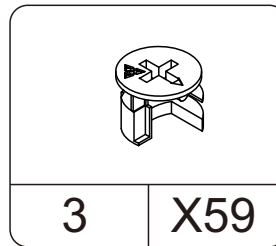

Cam lock  
Ø 12X10

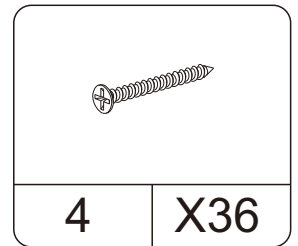

Screws  
M4x30

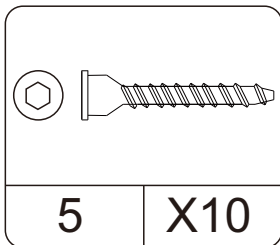

Screws  
M6.3x50

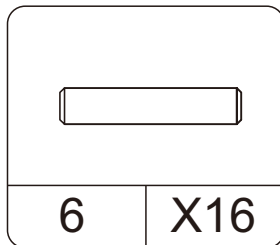

Wood dowel  
Ø6X30

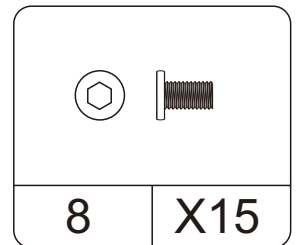
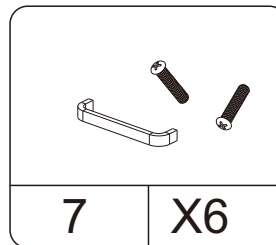

Screws  
M6x10

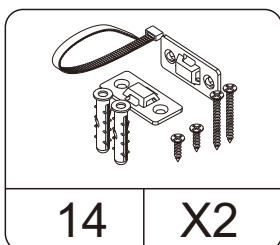
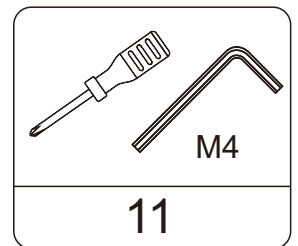
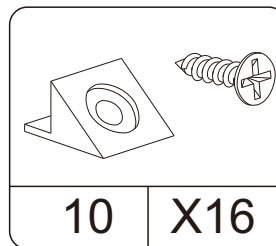
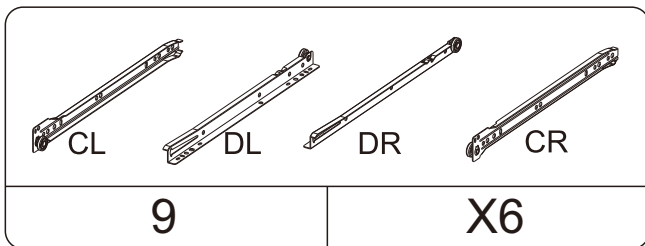

# INSTALLATION STEPS

STEP1:

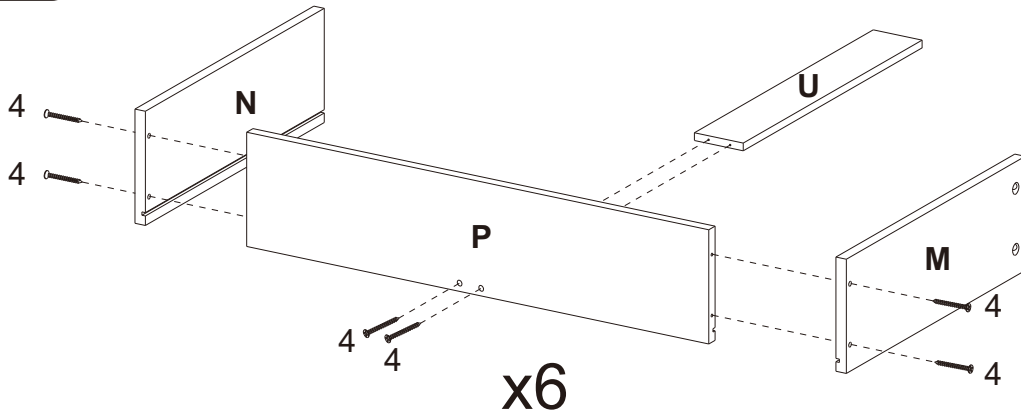
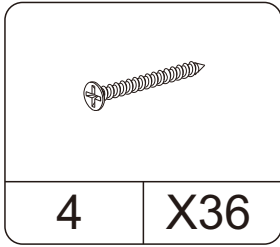

STEP2:

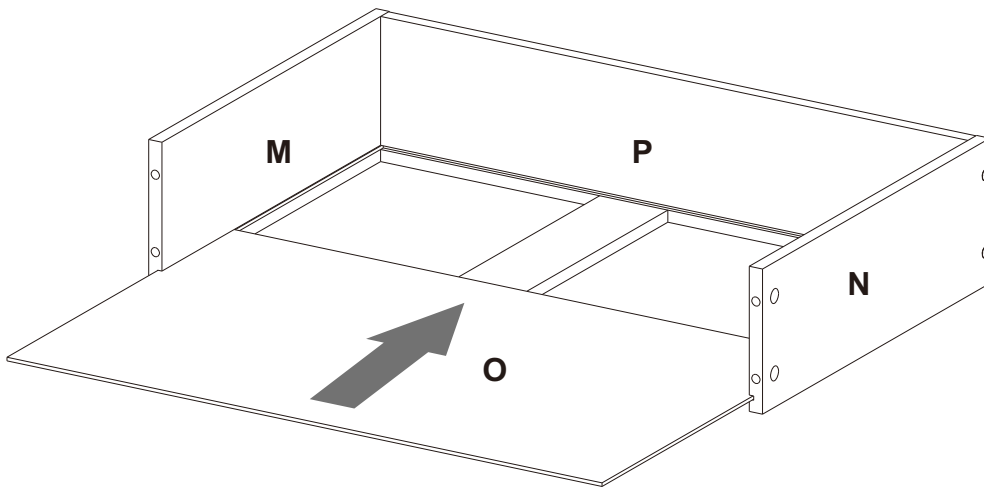

x6

# INSTALLATION STEPS

## STEP3:

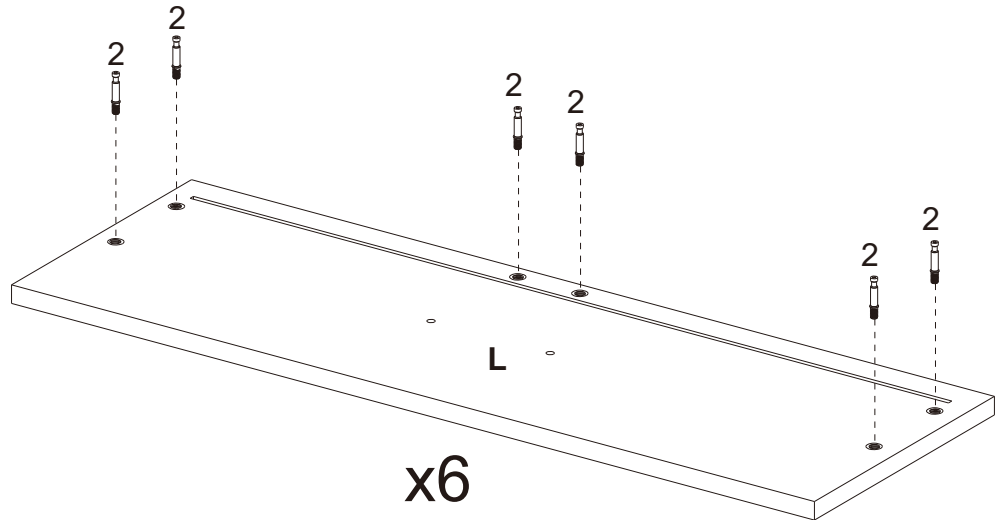
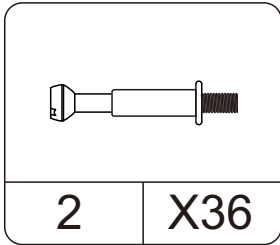

## STEP4:

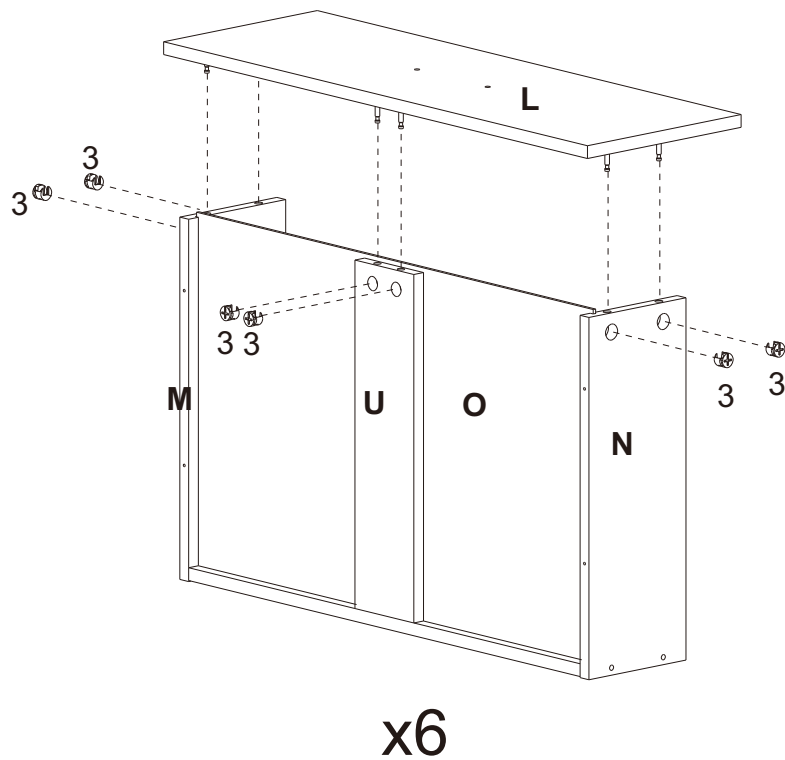
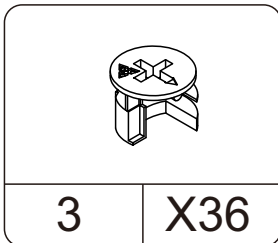

# INSTALLATION STEPS

## STEP5:

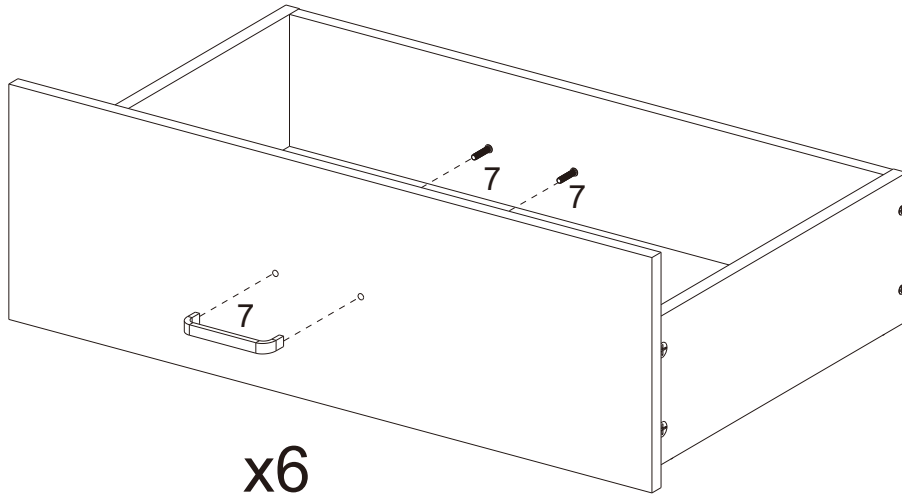
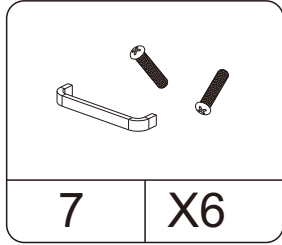

## STEP6:

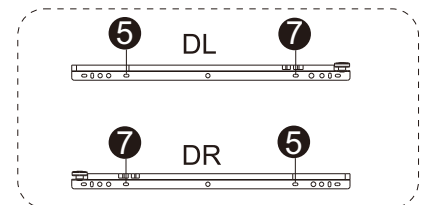
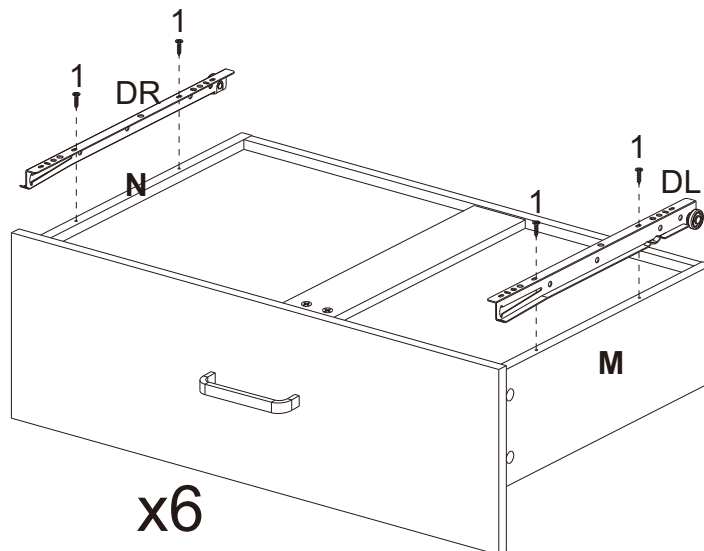
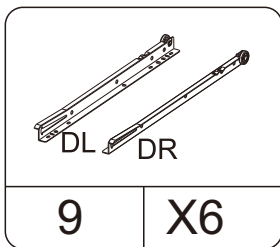
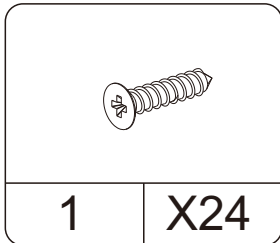

# INSTALLATION STEPS

## STEP7:

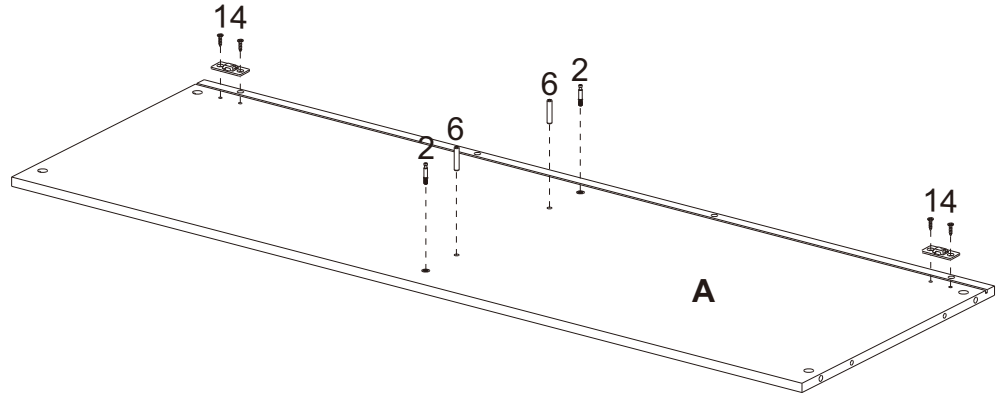
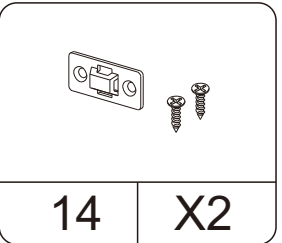
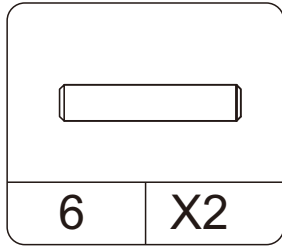
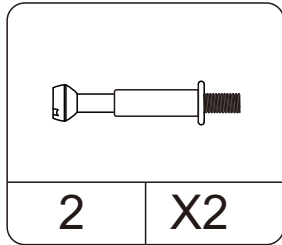

## STEP8:

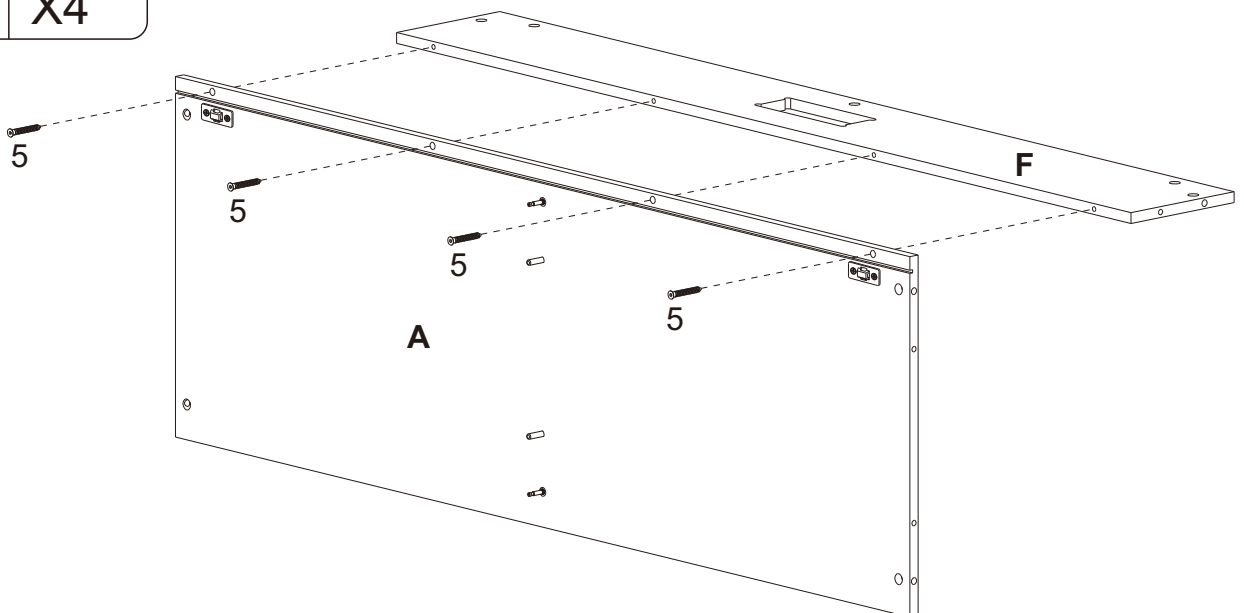
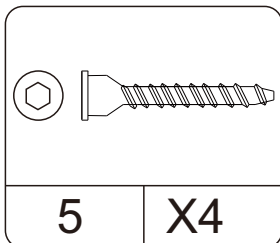

# INSTALLATION STEPS

## STEP9:

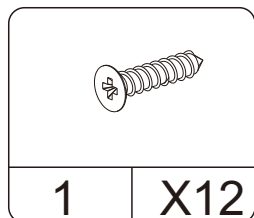
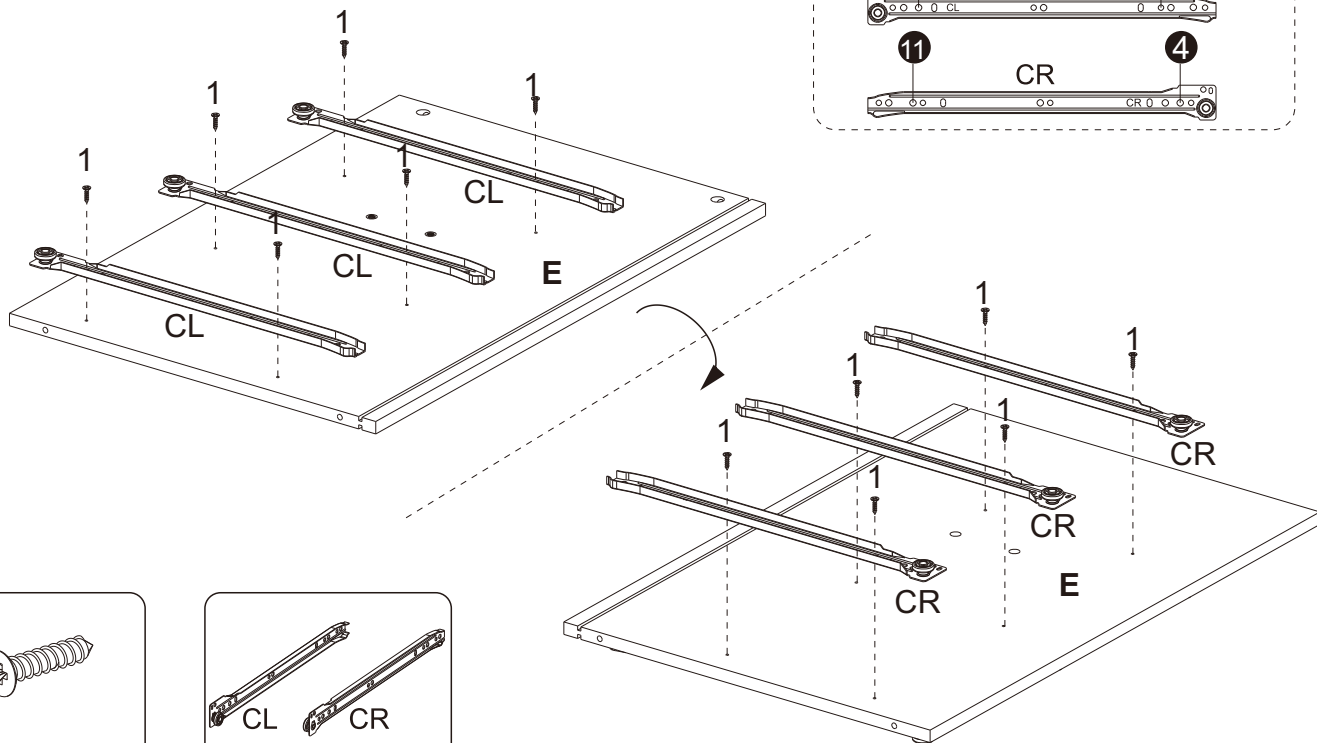

## STEP10:

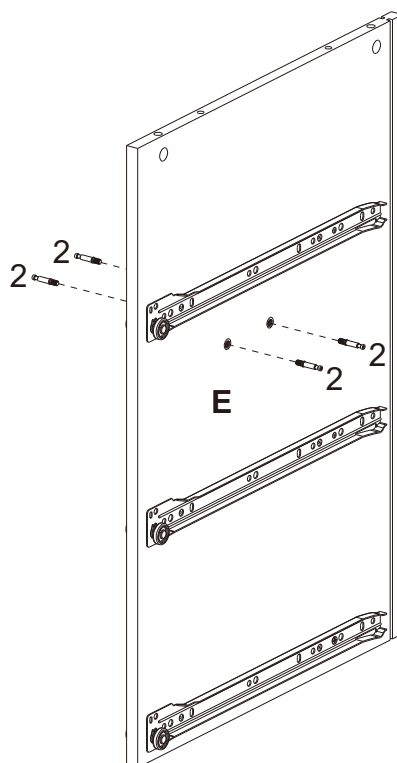
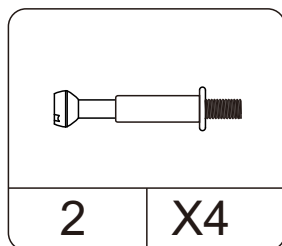

# INSTALLATION STEPS

## STEP11:

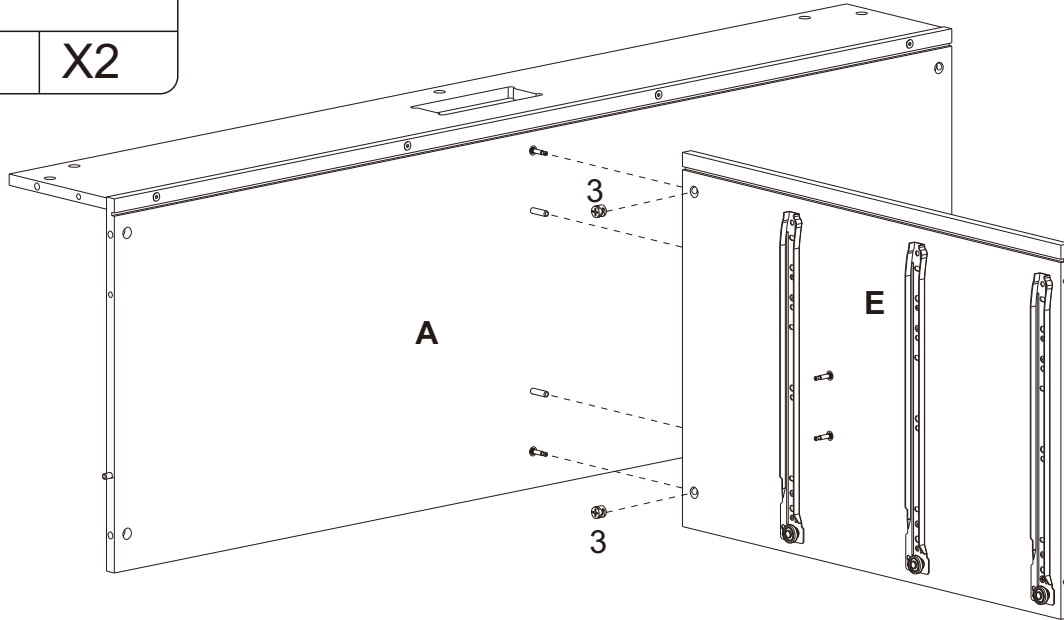
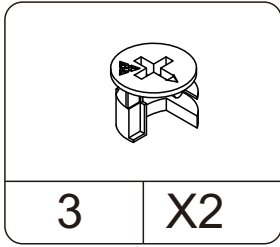

## STEP12:

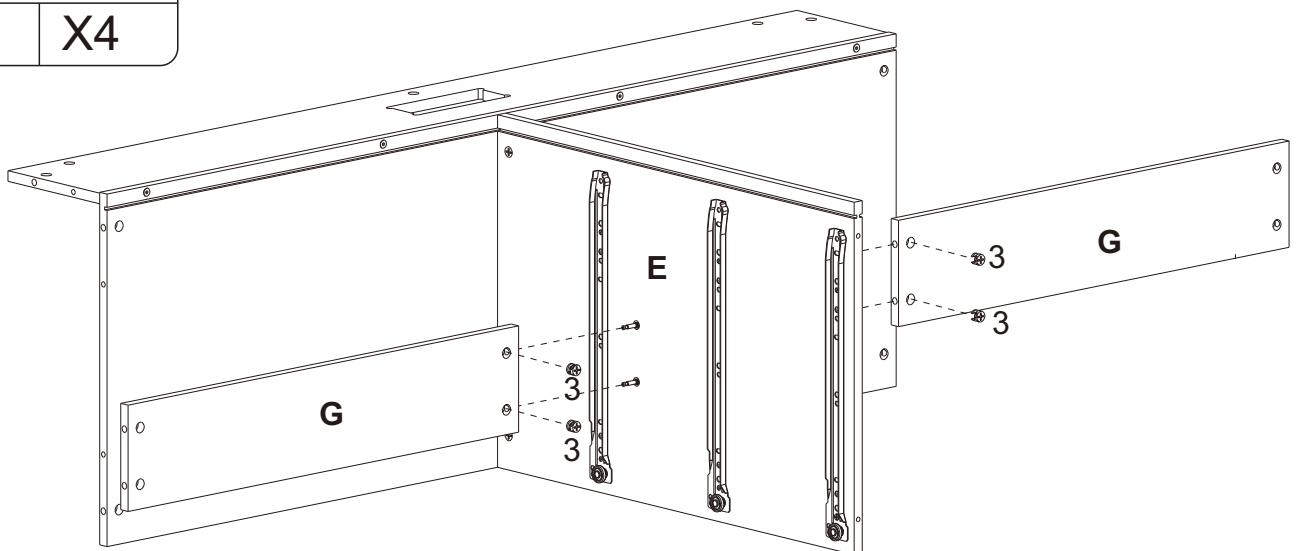
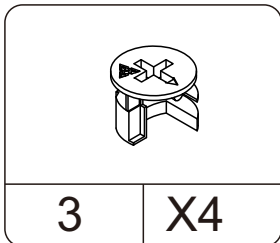

# INSTALLATION STEPS

## STEP13:

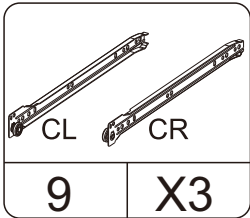
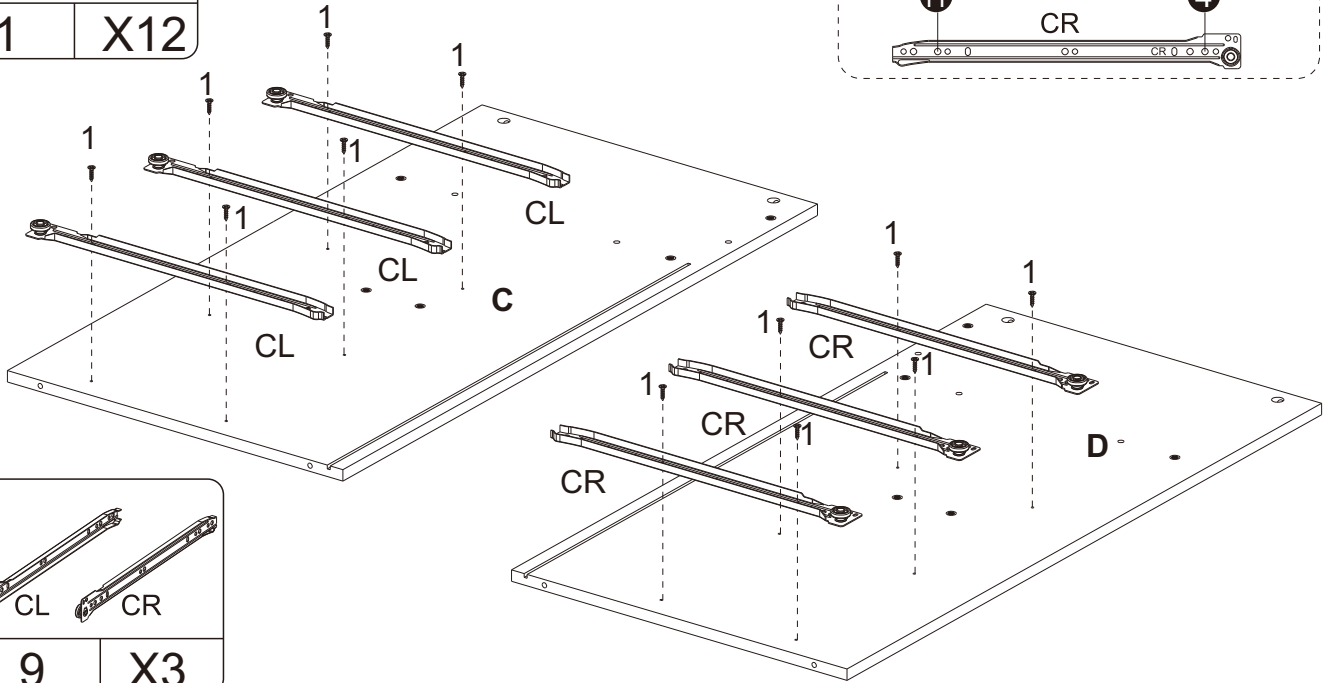
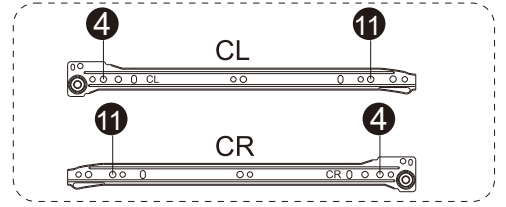
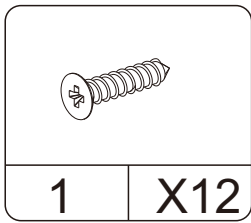

## STEP14:

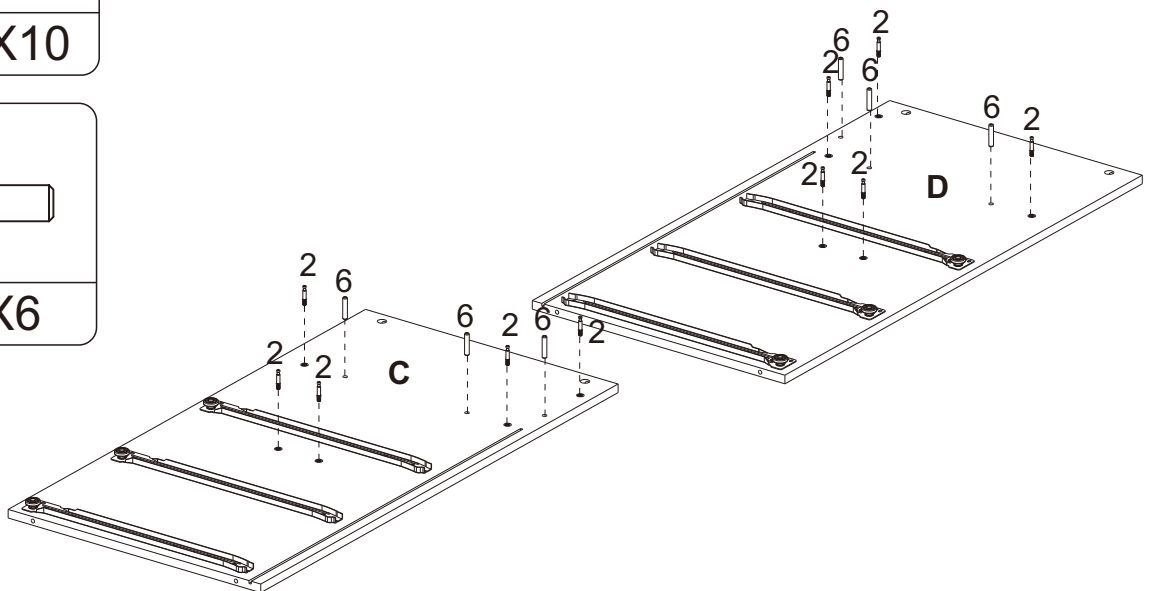
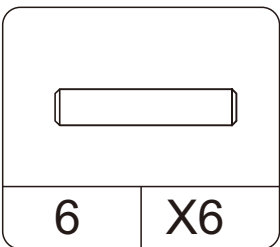
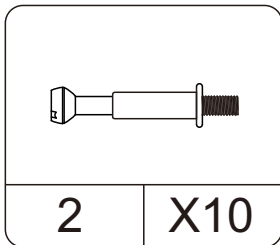

# INSTALLATION STEPS

## STEP15:

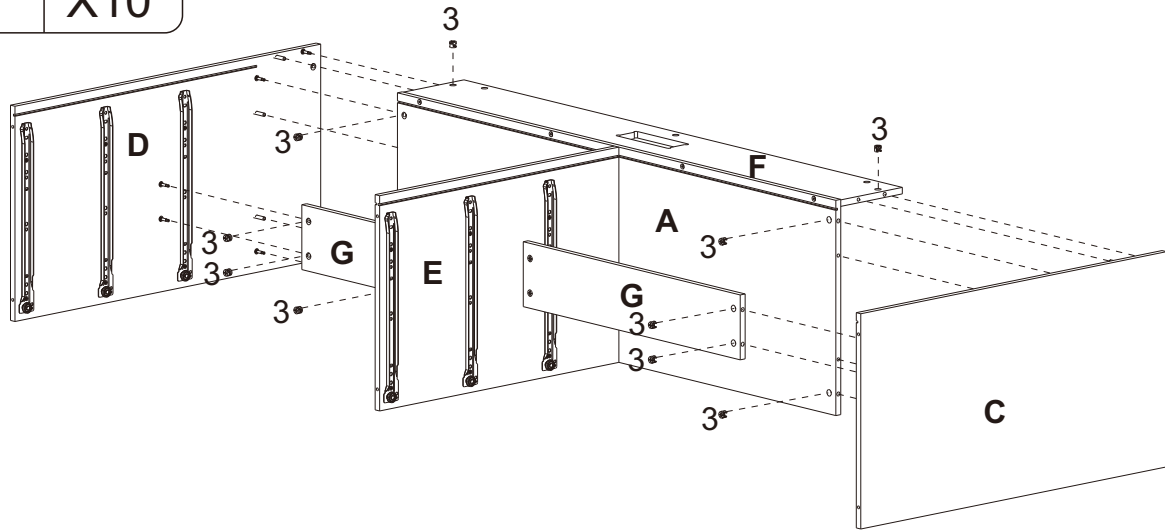
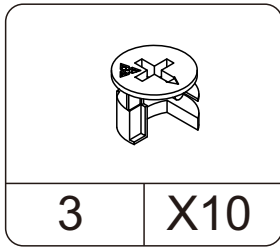

## STEP16:

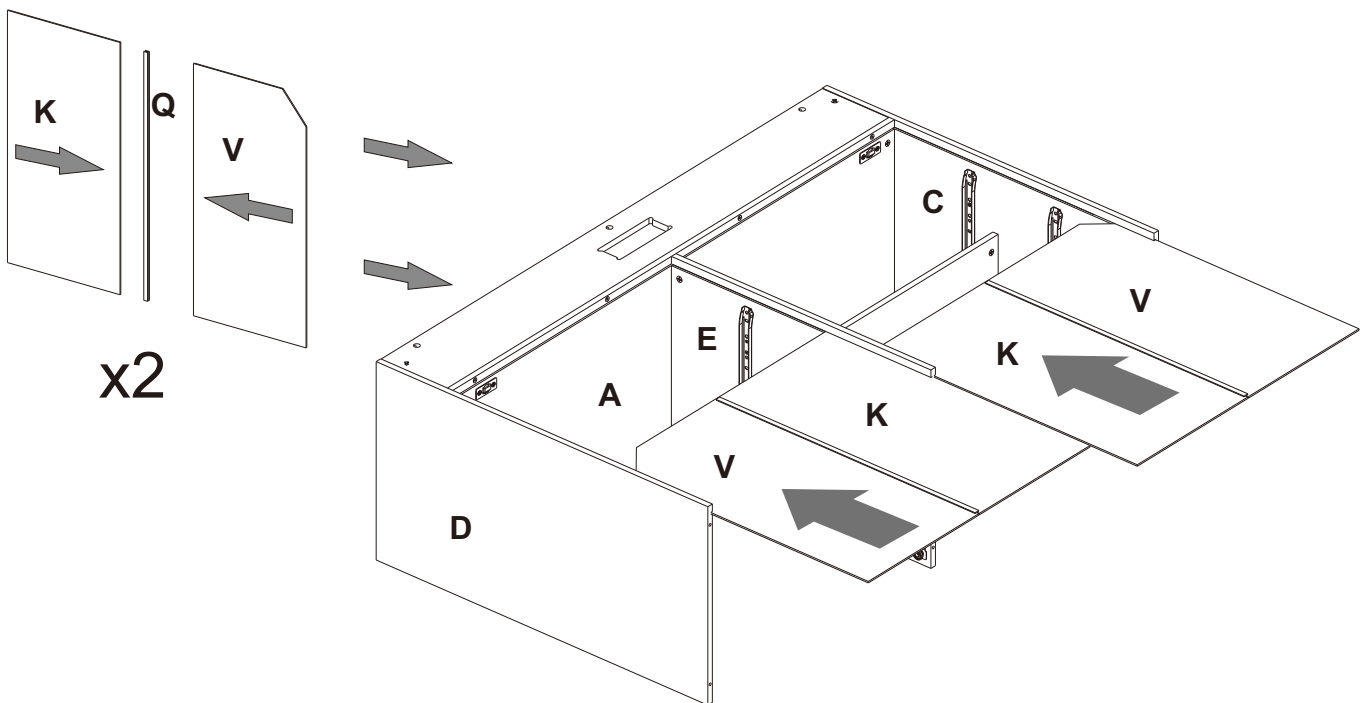

# INSTALLATION STEPS

## STEP17:

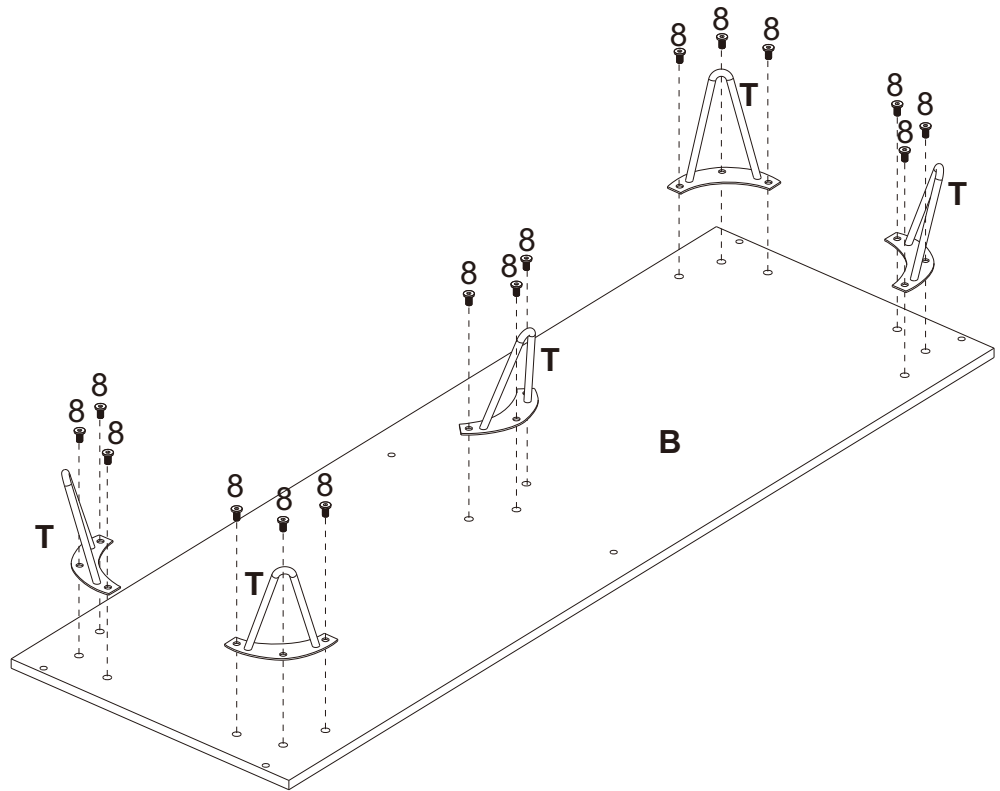
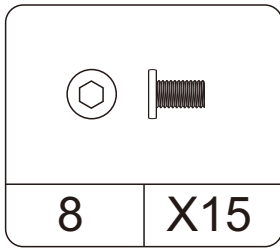

## STEP18:

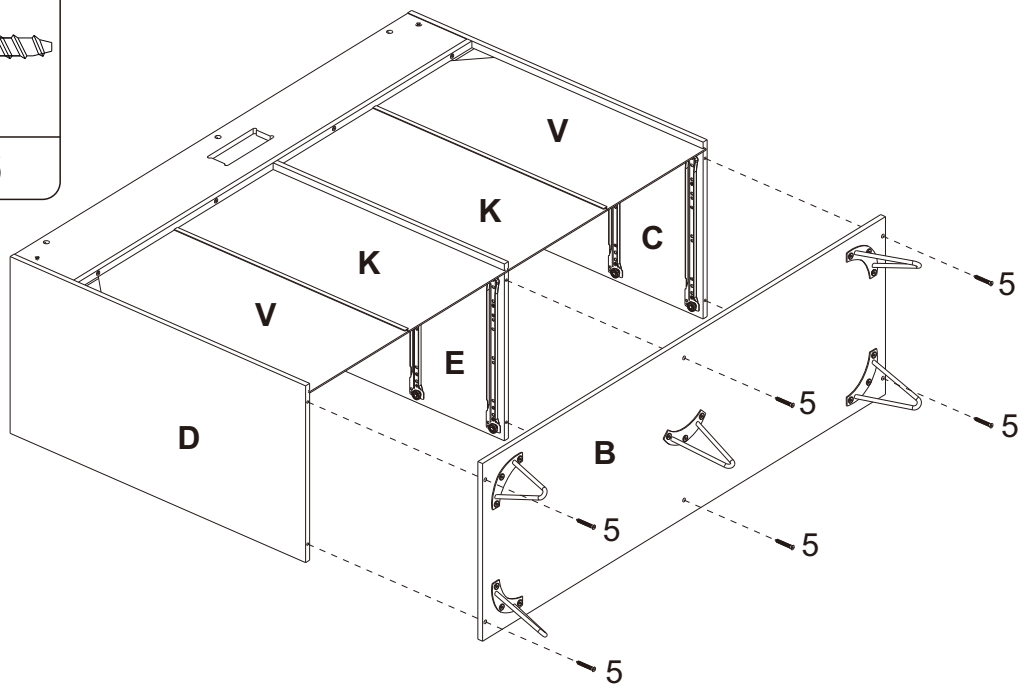
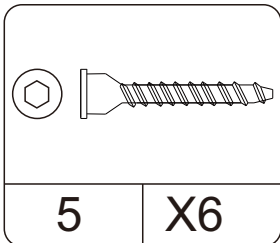

# INSTALLATION STEPS

## STEP19:

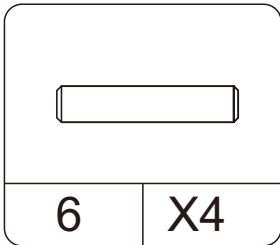
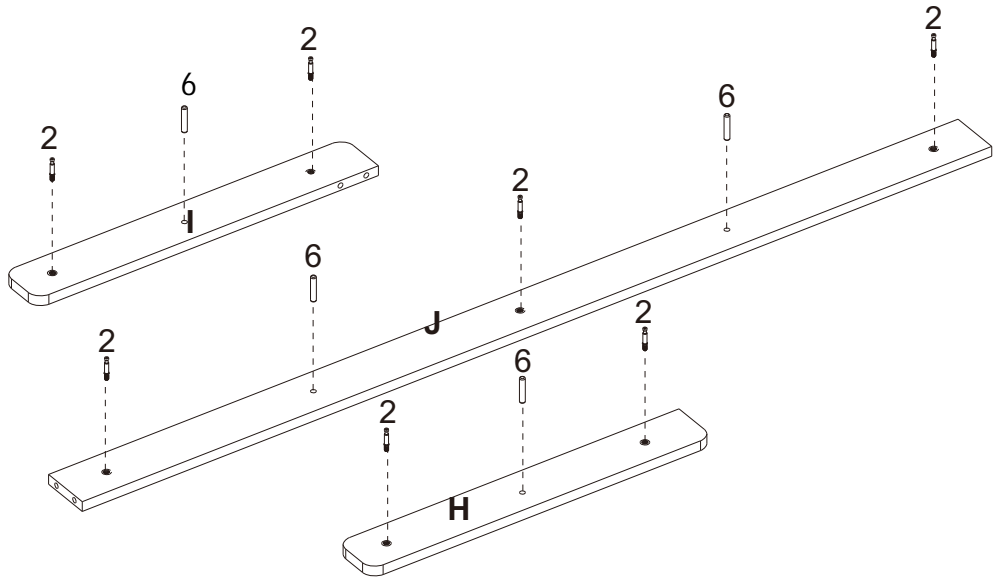
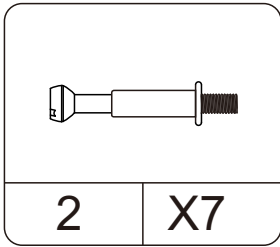

## STEP20:

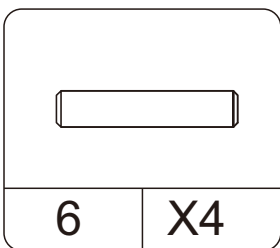
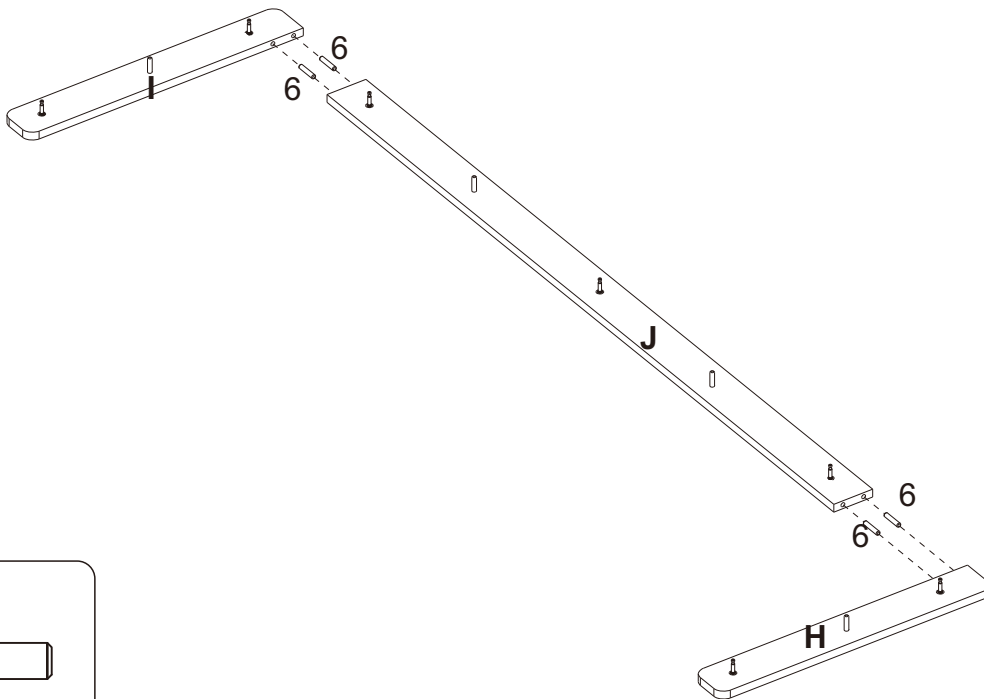

# INSTALLATION STEPS

STEP21:

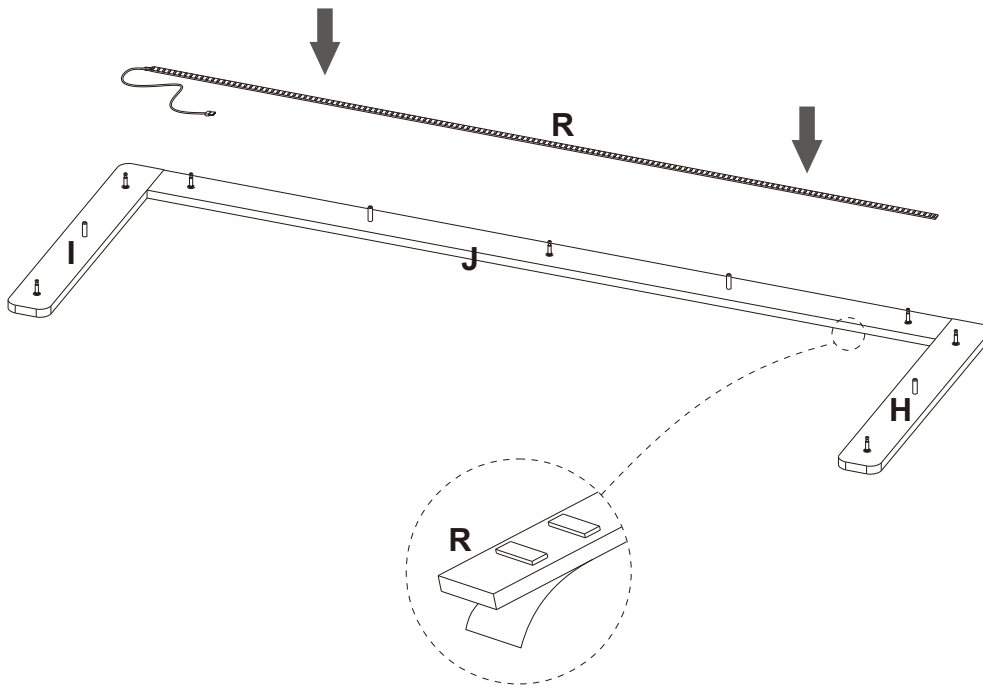

STEP22:

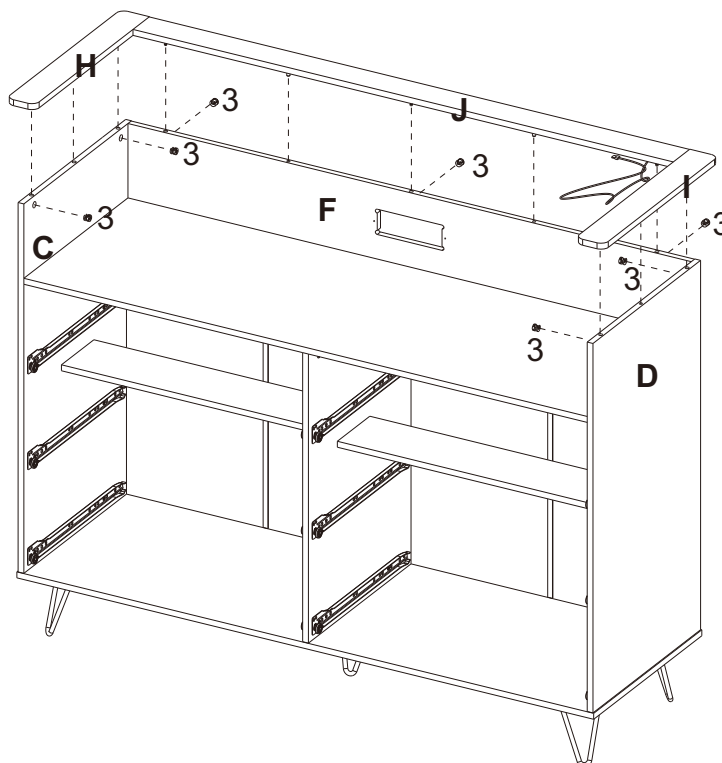
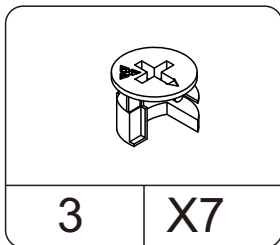

# INSTALLATION STEPS

## STEP23:

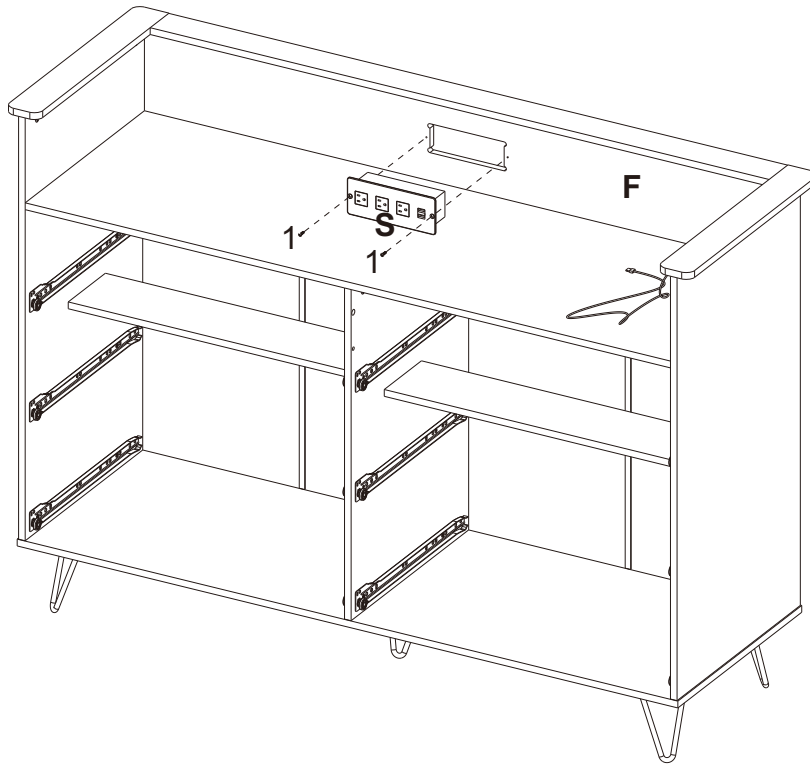
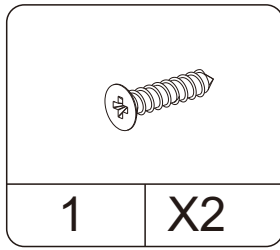

## STEP24:

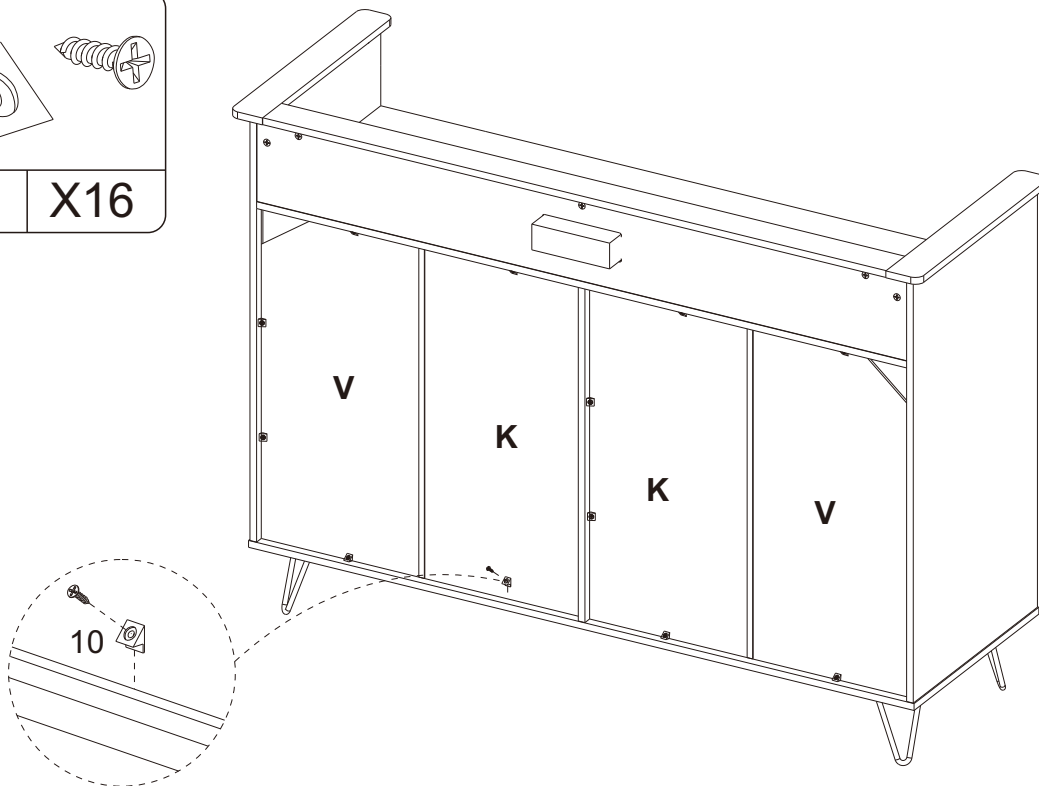
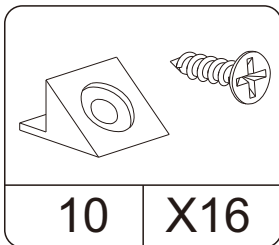

# INSTALLATION STEPS

## STEP25:

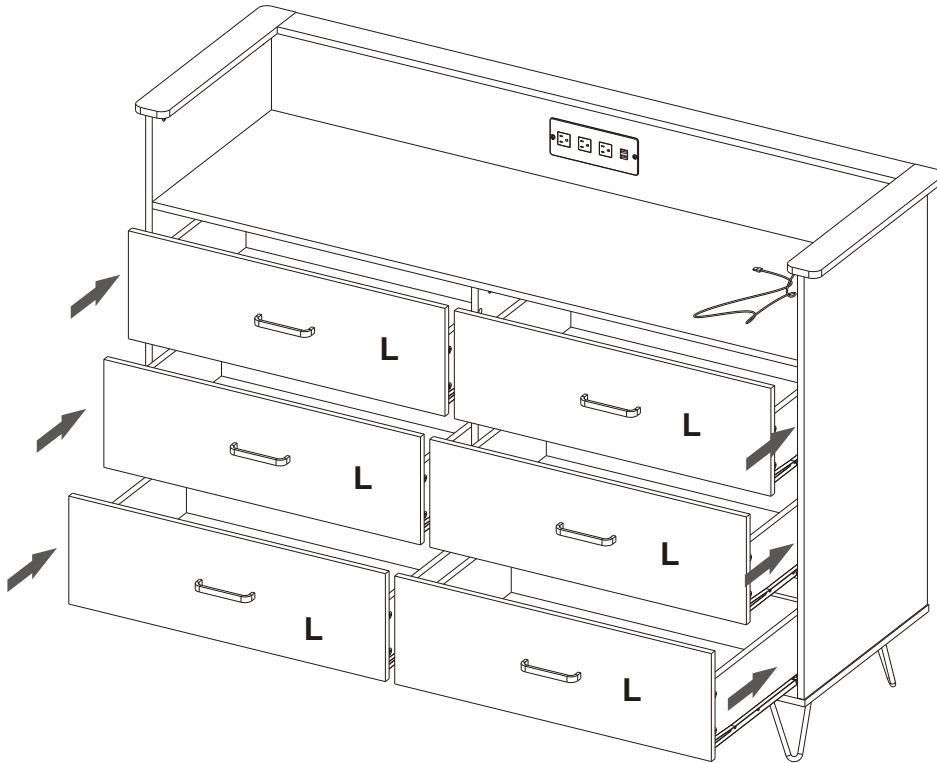

## STEP26:

