

ASSEMBLY INSTRUCTIONS & PARTS IDENTIFICATION

COUNTER HEIGHT TABLE DRIFTWOOD

Thank you for purchasing this quality product. Be sure to check all packing material carefully for small parts that may have come loose inside the carton during shipment.

Parts key			Hardware kit			
No	Qty	Description	No	Description		Qty
1A	2 pcs	Left Side Facing Extension Mechanism	A	Bolt	Ø7.8 x 50	6 pcs
1B	2 pcs	Right Side Facing Extension Mechanism	B	Hex Nut	Ø8	8 pcs
2	2 pcs	Left Side Facing Leg	C	Semi lunar washer	Ø8 x 30	4 pcs
3	2 pcs	Right Side Facing Leg	D	Lock washer	Ø8	14 pcs
4	1 pc	Center Connecting Stretcher	E	Big Flat washer	Ø10 x 22	8 pcs
5	2 pcs	Side Stretcher	F	Small Flat washer	Ø8 x 16	2 pcs
6	4 pcs	Floor Glide	G	Allen Key	K4	1 pc
			H	Wrench	12	1 pc

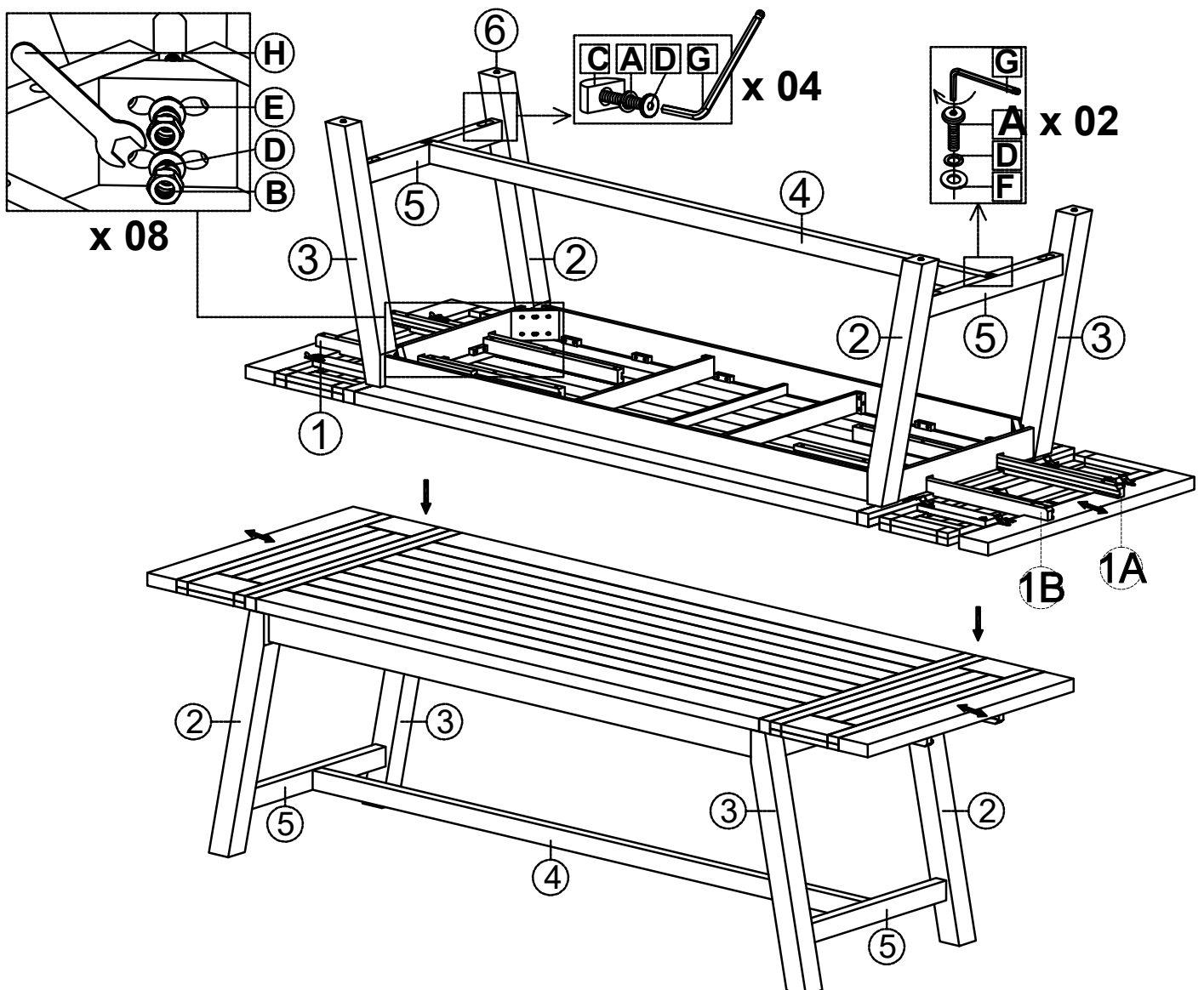

**ASSEMBLY INSTRUCTIONS &
PARTS IDENTIFICATION**

**COUNTER HEIGHT TABLE
DRIFTWOOD**

Thank you for purchasing this quality product. Be sure to check all packing material carefully for small parts that may have come loose inside the carton during shipment.

The leaf out

