

# INSTRUC TION MANU AL

## 2-Piece Outdoor Single Chairs

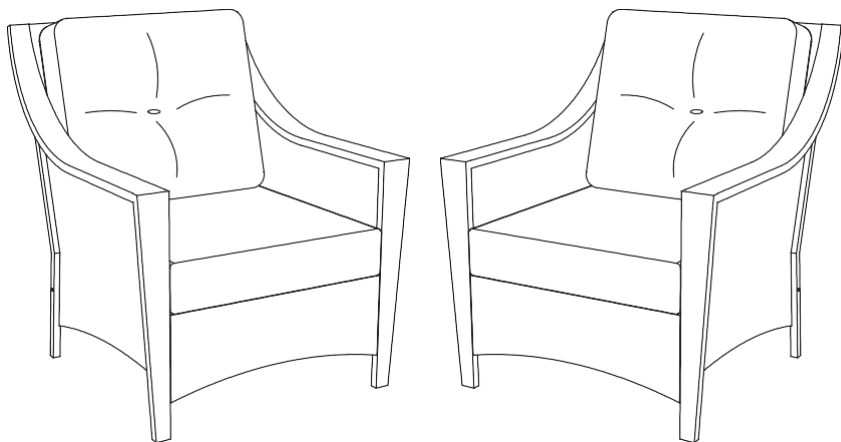

Keep the Instructions for Future Reference.  
If you purchased the chair on-line and have any questions  
or concerns please contact us with email.  
Email: [slhhomegarden@outlook.com](mailto:slhhomegarden@outlook.com)

[The body of the page contains extremely faint, illegible text that appears to be bleed-through from the reverse side of the paper. The text is too light to transcribe accurately.]

## **WARNING:** ||

Proper use of the chair is for single person seating only. The chair is not to be used for standing purposes and will not function as a stool or step-ladder. Use on even surfaces only. Single Chair tested for use at weight of 250 lbs. Improper use of this product or failure to use as directed may result in injury. Not intended for commercial use.

## **IMPORTANT:** ||

Please read all the instructions and warnings before assembling. In order to make the whole product adjust to the best, please install all the screws on the product before fully tighten and note to put the washer to the screw before putting the screw into the screw hole.

## **SAFETY INFORMATION:** ||

- Keep all children and pets away from assembly area. Children and pets should be supervised when they are in the area of the product construction.
- Keep assembly area at least 6 feet from any obstruction such as a fence, garage, house, overhanging branches, laundry line or electrical wires.
- Some parts may contain sharp edges. When assembling and using this product, basic safety precautions should always be followed to reduce the risk of personal injury and damage to the product. Please read all instructions before assembly and use.
- Check all bolts for tightness before use, IMPORTANT-check and tighten bolts often to keep them secure!
- The chair is not to be used for standing purposes and will not function as a tool or step-ladder. Use on even surfaces only.

## **CARE & MAINTENANCE:** ||

- STAIN RESISTANT CUSHIONS CARE: KEEP THE CUSHIONS IN STORAGE IN RAINY DAYS
- SPILLS: Immediately wipe up the spill using a white damp doth. Repeat process if necessary until stain is gone. Allow cushion to air dry.
- FABRIC CARE: Hand wash only, non-chlorine bleach when needed, lay flat to dry. Cool iron if necessary. Do not dry clean.
- RESIN WICKER PRODUCT CARE: Before using, clean the product completely with a soft dry towel. When not in use, wipe free of any dirt or loose objects, wash with a mild solution of soap and water, rinse thoroughly and dry completely. Do not use strong detergent or abrasive cleaners. Over time nuts and bolts can loosen. Occasionally, check nut and bolts on furniture, re-tighten if necessary.
- RUST PREVENTION: Use a waterproof furniture cover during rain or snow, or any shield that can be covered.

## Part List ▼ |||

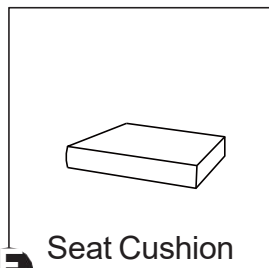
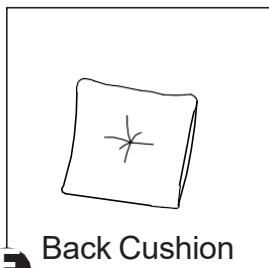
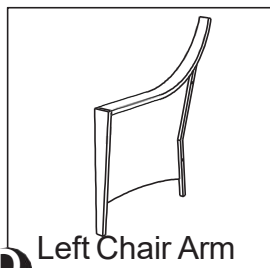
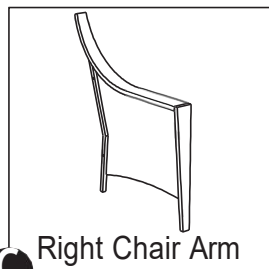
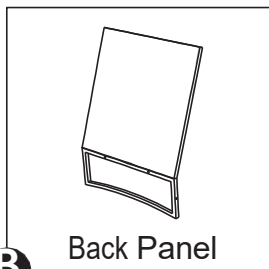
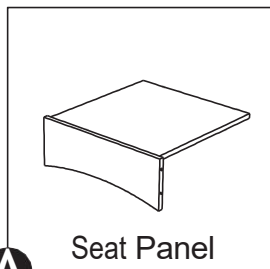

## Hardware ▼ |||

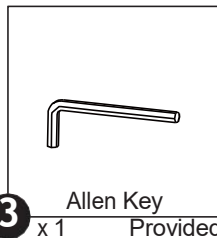
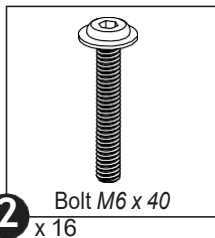
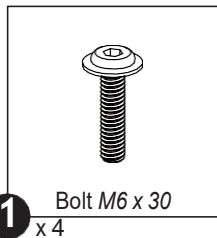

1 Person Assembly  
-----

### ASSEMBLY TIP:

Please screw the parts together at 80% loose, it will help you assemble them easily. When all the parts are assembled together, tighten the screws up 100% in the end to make the product stable.

STEP 1 · Attach Seat Panel (A) to Back Panel (B) using 2 Bolts (1) as shown below.

1

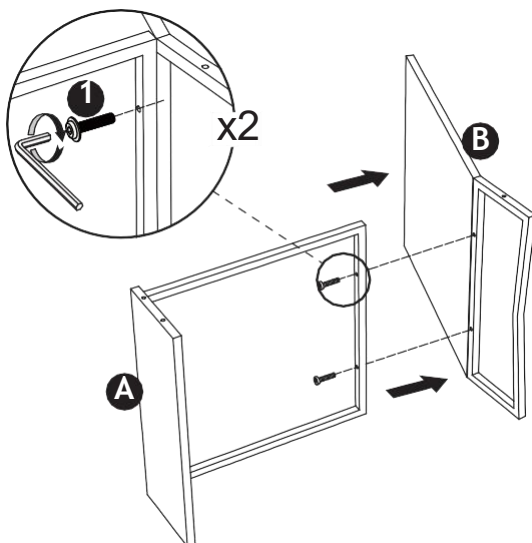

Tighten the bolts to 80% tightness

STEP 2 · Attach Left Chair Arm (D) to Seat Panel (A) and Back Panel (B) using 4 Bolts (2) as shown below.

2

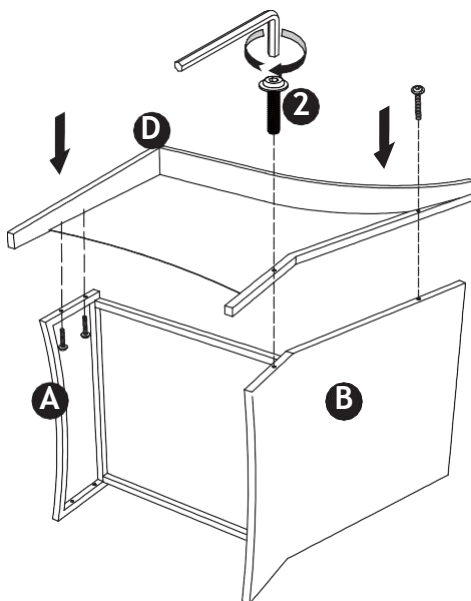

Tighten the bolts to 80% tightness

**STEP 3** · Attach Right Chair Arm (C) to Seat Panel (A) and Back Panel (B) using 4 Bolts (2) as shown below.

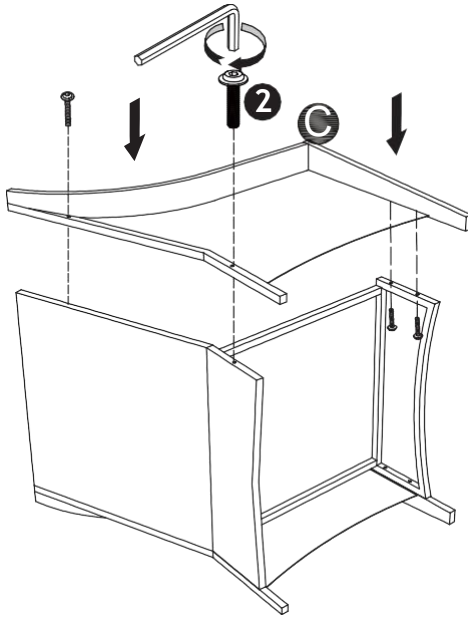

**100%**  
Adjust the balance  
of the chair and  
tighten the bolts  
to 100% tightness

**STEP 4** · Put Seat Cushion (F) and Back Cushion (E) to the chair frame.  
· Repeat with the other single chair.

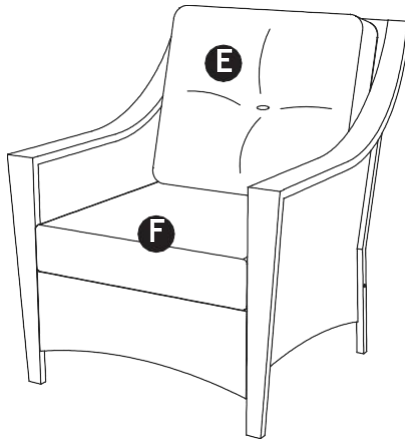

# Warranty:

We are committed to providing quality outdoor furniture and offer a one-year limited warranty on this product.

## Terms and Conditions

This warranty covers defects in materials and workmanship under normal use and care for a period of one year from the date of purchase. Proof of purchase (dated receipt or invoice) is required for all warranty claims.

## Customer Responsibilities

The customer is responsible for all freight and packing charges associated with returning the product to our service center and shipping it back after repair or replacement.

## Exclusions

This warranty does not cover:

- Normal wear and tear, including scratches, stains, fading, or discoloration.
- Damage caused by misuse, accidents, neglect, or improper maintenance.
- Damages resulting from exposure to extreme weather conditions.
- Commercial use of the product.

## How to File a Claim

To submit a warranty claim:

Provide proof of purchase. Include a detailed description of the issue and photos, if applicable.

Contact our customer service team for assistance. If your claim is approved, we will repair or replace the product or provide a comparable solution at our discretion.

This warranty is non-transferable and applies only to the original purchaser. For optimal product performance, we recommend following all care and maintenance instructions.

